

TOSHIBA Transistor Silicon NPN Epitaxial Type (PCT Process)

RN1421,RN1422,RN1423,RN1424 RN1425,RN1426,RN1427

Switching, Inverter Circuit, Interface Circuit
And Driver Circuit Applications

Unit: mm

- High current type (I_C (max) = 800mA)
- With built-in bias resistors
- Simplify circuit design
- Reduce a quantity of parts and manufacturing process
- Low V_{CE} (sat)
- Complementary to RN2401~RN2406

Equivalent Circuit and Bias Resister Values

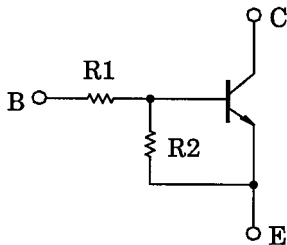

Type No.	R1 (kΩ)	R2 (kΩ)
RN1421	1	1
RN1422	2.2	2.2
RN1423	4.7	4.7
RN1424	10	10
RN1425	0.47	10
RN1426	1	10
RN1427	2.2	10

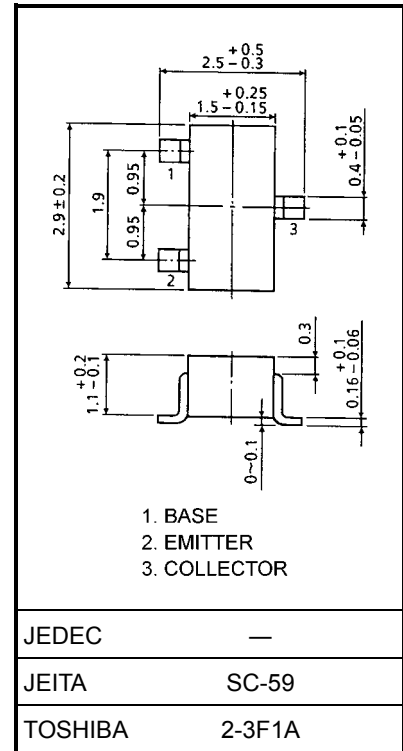

Weight: 0.012 g (typ.)

Maximum Ratings ($T_a = 25^\circ\text{C}$)

Characteristic	Symbol	Rating	Unit
Collector-base voltage	V_{CBO}	50	V
Collector-emitter voltage			
Emitter-base voltage	V_{EBO}	10	V
		5	
		6	
Collector current	I_C	800	mA
Collector power dissipation	P_C	200	mW
Junction temperature	T_j	150	$^\circ\text{C}$
Storage temperature range	T_{stg}	-55~150	$^\circ\text{C}$

Electrical Characteristics (Ta = 25°C)

Characteristic		Symbol	Test Circuit	Test Condition	Min	Typ.	Max	Unit	
Collector cut-off current	RN1421~1427	I_{CBO}	—	$V_{CB} = 50V, I_E = 0$	—	—	100	nA	
		I_{CEO}		$V_{CE} = 50V, I_B = 0$	—	—	500		
Emitter cut-off current	RN1421	I_{EBO}	—	$V_{EB} = 10V, I_C = 0$	3.85	—	7.14	mA	
	RN1422				1.75	—	3.25		
	RN1423				0.82	—	1.52		
	RN1424			0.38	—	0.71			
	RN1425			$V_{EB} = 5V, I_C = 0$	0.365	—	0.682		
					RN1426	0.35	—		0.65
					RN1427	$V_{EB} = 6V, I_C = 0$	0.378		—
DC current gain	RN1421	h_{FE}	—	$V_{CE} = 1V, I_C = 100mA$	60	—	—	—	
	RN1422				65	—	—		
	RN1423				70	—	—		
	RN1424				90	—	—		
	RN1425				90	—	—		
	RN1426				90	—	—		
	RN1427				90	—	—		
Collector-emitter saturation voltage	RN1421~1427	$V_{CE(sat)}$	—	$I_C = 50mA, I_B = 2mA$	—	—	0.25	V	
				$I_C = 50mA, I_B = 1mA$					
Input voltage (ON)	RN1421	$V_{I(ON)}$	—	$V_{CE} = 0.2V, I_C = 100mA$	1.0	—	3.5	V	
	RN1422				1.4	—	4.5		
	RN1423				2.0	—	6.5		
	RN1424				3.0	—	12.0		
	RN1425				0.6	—	2.0		
	RN1426				0.7	—	2.5		
	RN1427				1.0	—	3.0		
Input voltage (OFF)	RN1421~1424	$V_{I(OFF)}$	—	$V_{CE} = 5V, I_C = 0.1mA$	0.8	—	1.3	V	
	RN1425, 1426				0.4	—	0.8		
	RN1427				0.5	—	1.0		
Transition frequency	RN1421~1427	f_T	—	$V_{CE} = 5V, I_C = 20mA$	—	300	—	MHz	
Collector Output capacitance	RN1421~1427	C_{ob}	—	$V_{CB} = 10V, I_E = 0, f = 1MHz$	—	7	—	pF	
Input resistor	RN1421	R1	—	—	0.7	1.0	1.3	kΩ	
	RN1422				1.54	2.2	2.86		
	RN1423				3.29	4.7	6.11		
	RN1424				7	10	13		
	RN1425				0.329	0.47	0.61		
	RN1426				0.7	1.0	1.3		
	RN1427				1.54	2.2	2.86		
Resistor ratio	RN1421~1424	R1/R2	—	—	0.9	1.0	1.1	—	
	RN1425				0.0423	0.047	0.0517		
	RN1426				0.09	0.1	0.11		
	RN1427				0.2	0.22	0.24		

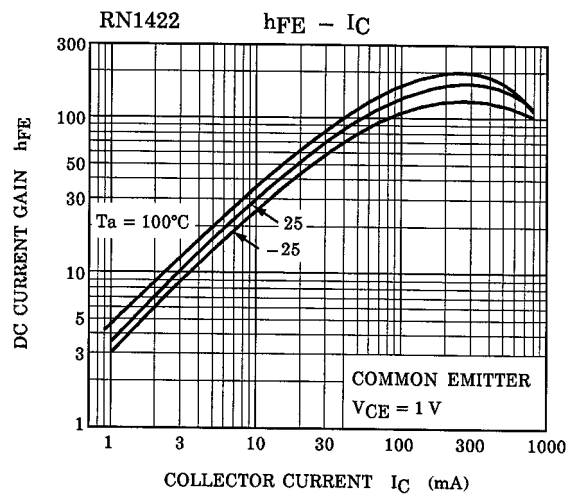
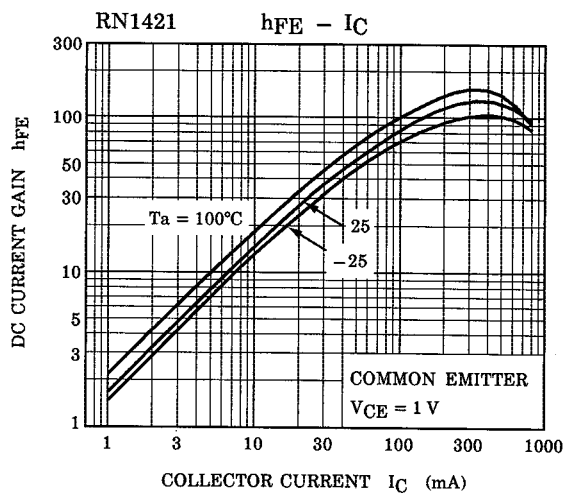
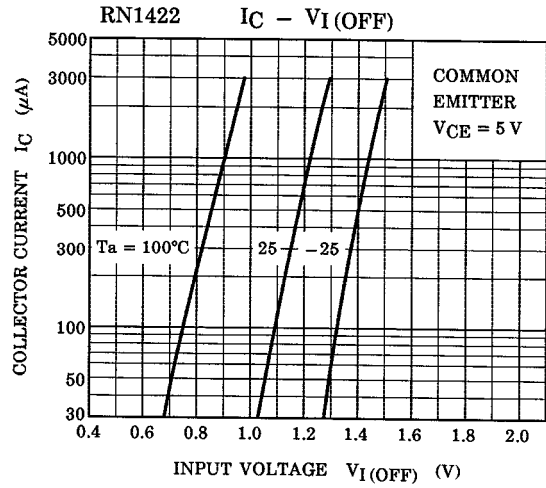
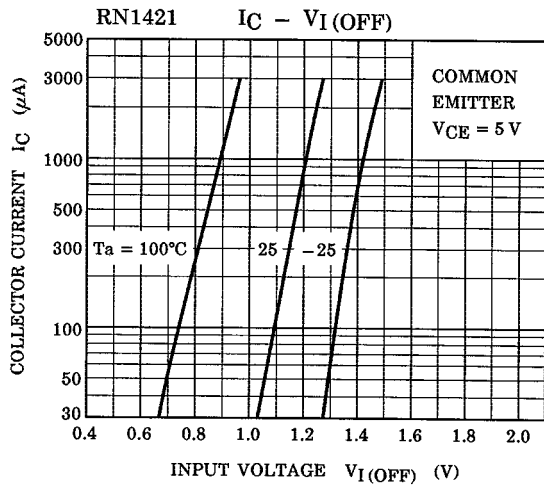
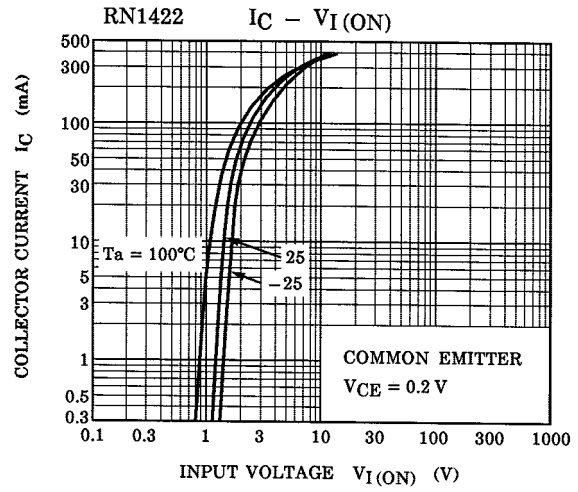
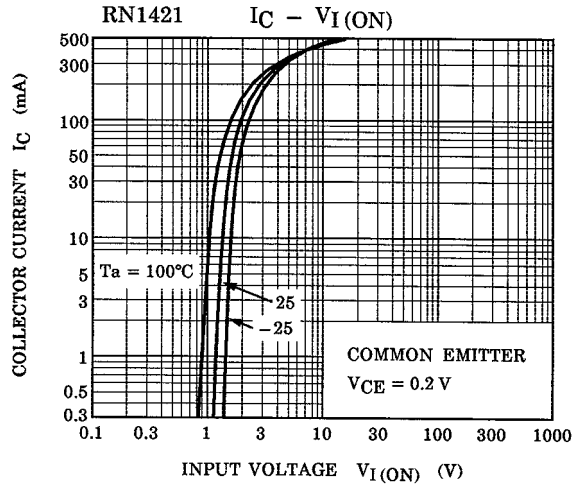

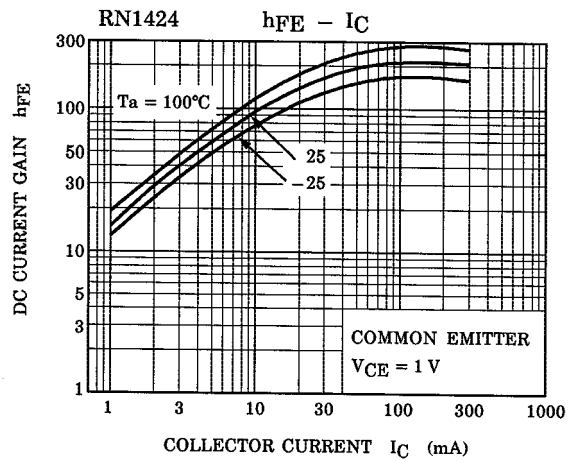
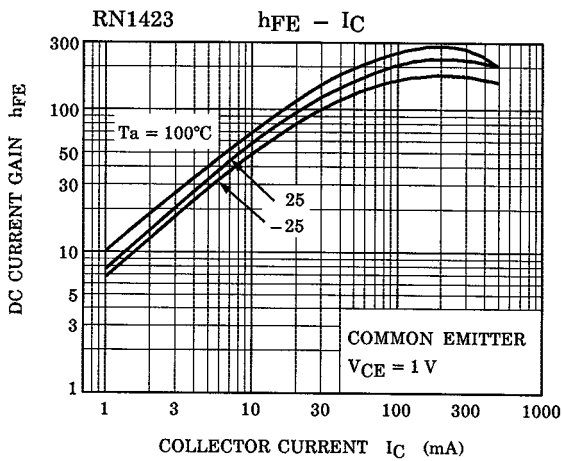
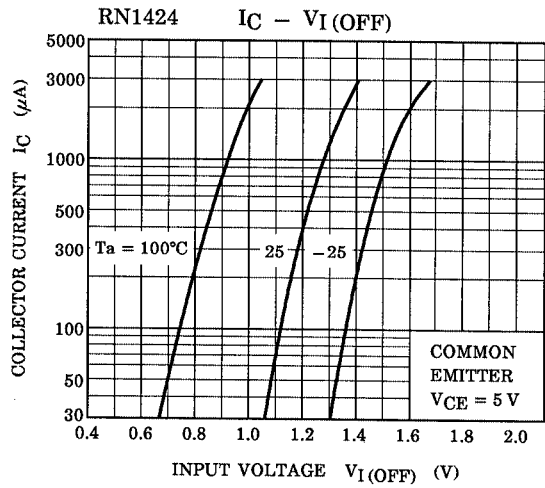
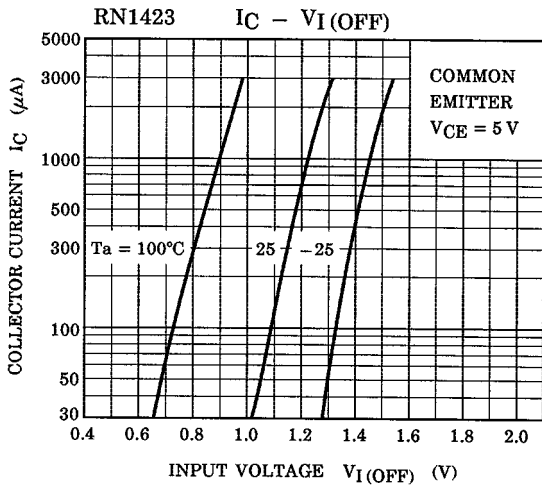
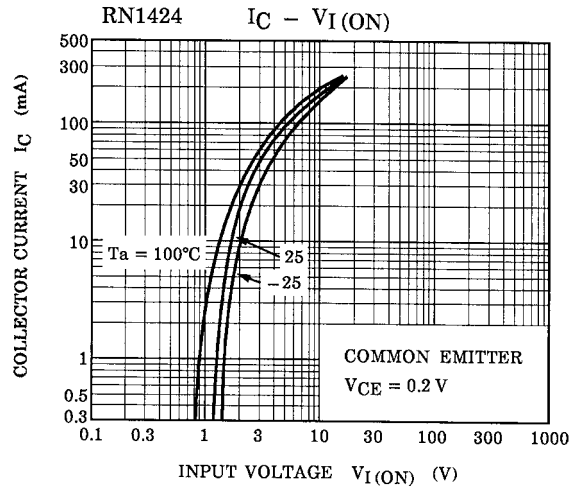
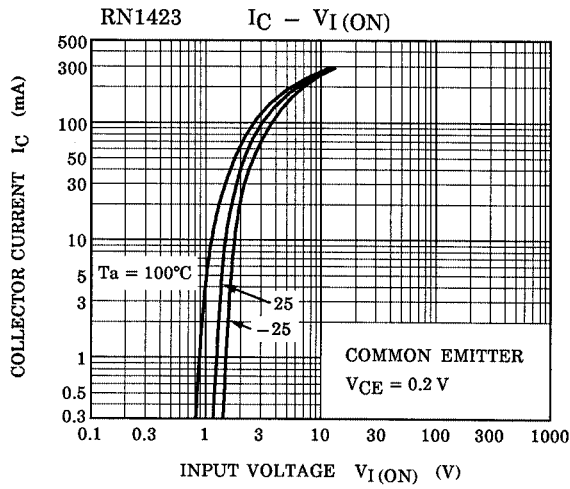

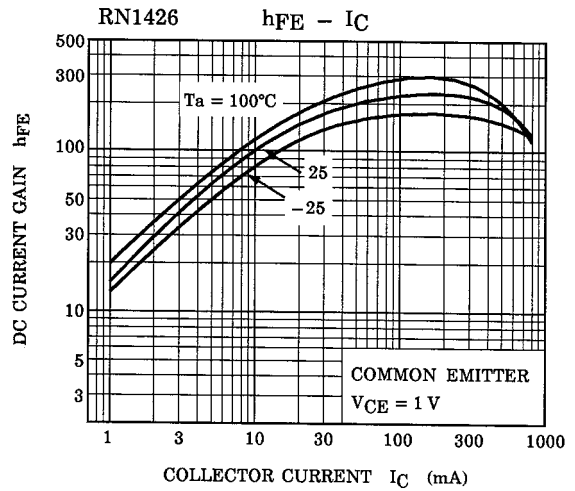
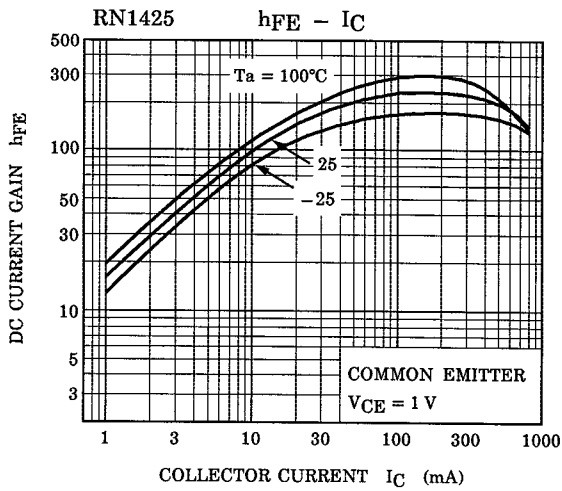
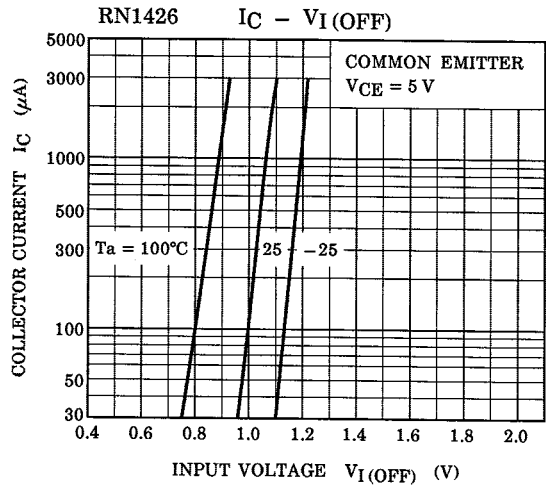
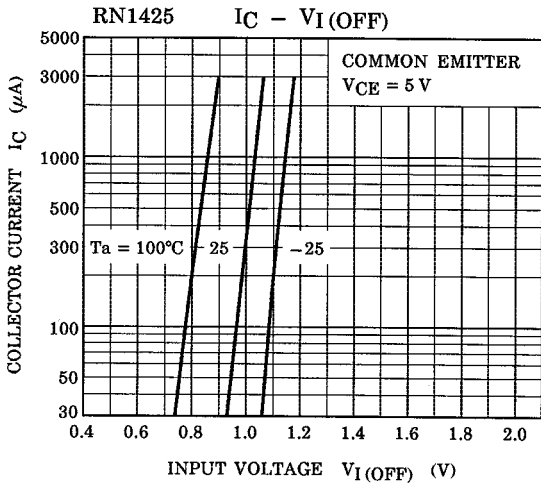
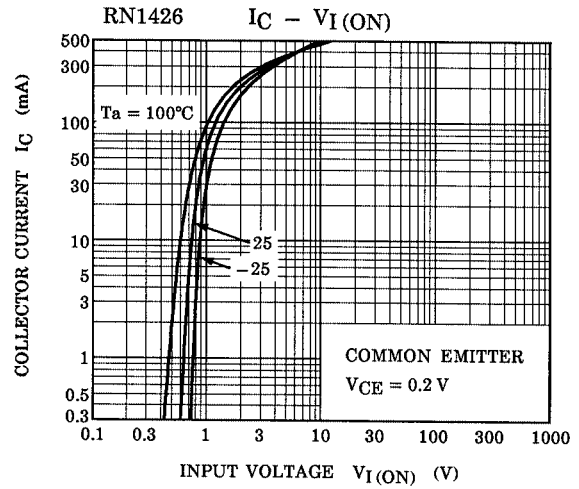
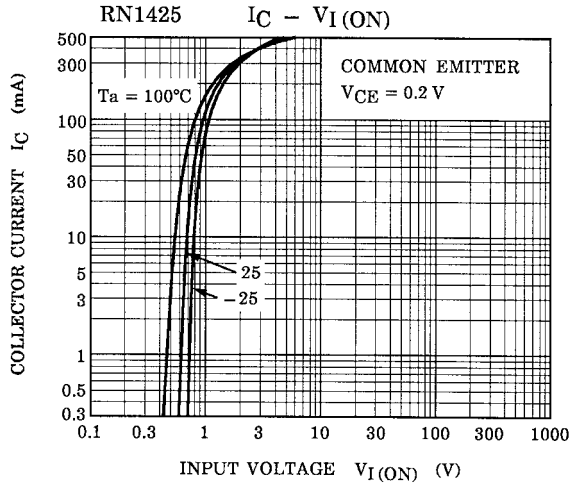

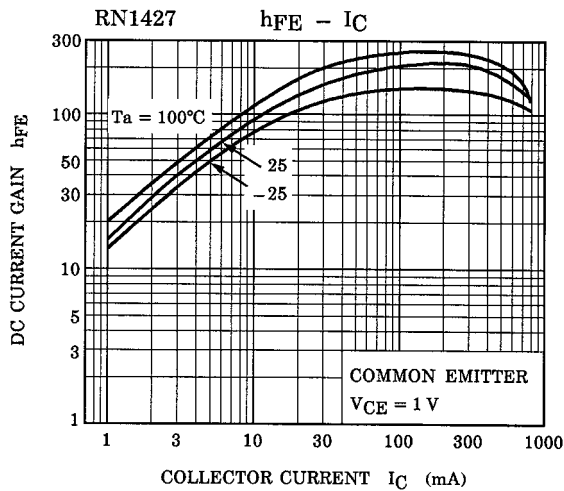
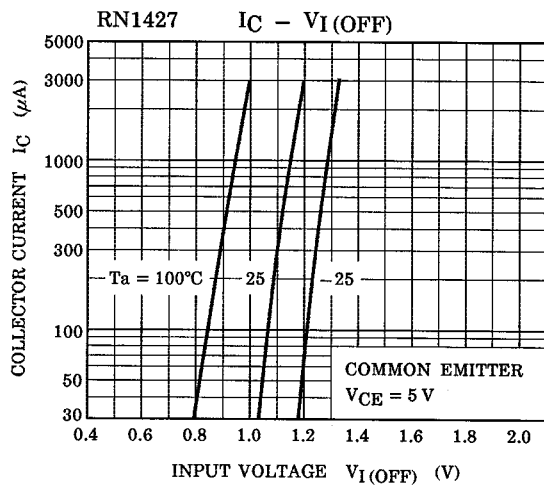
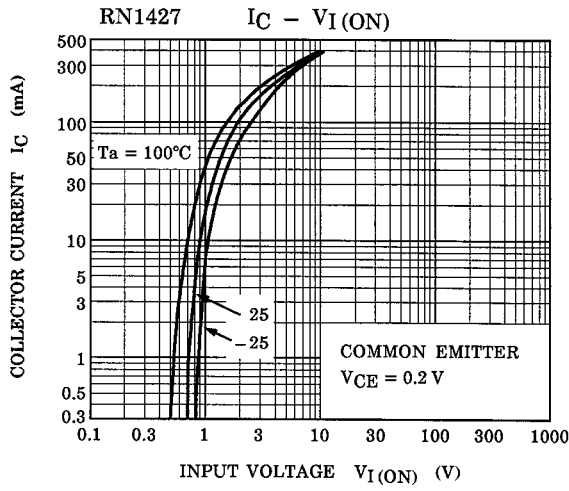

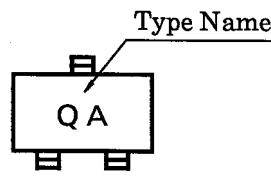
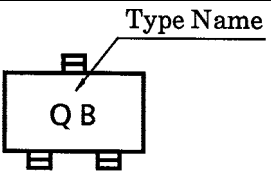
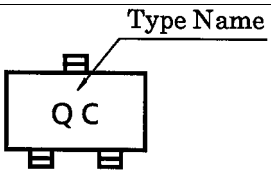
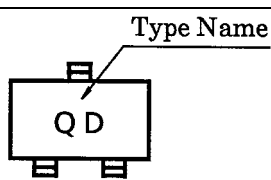
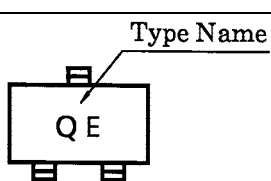
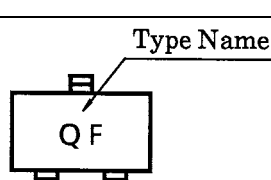
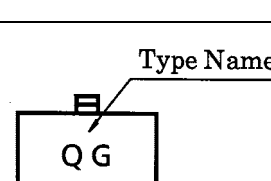
Type Name	Marking
RN1421	
RN1422	
RN1423	
RN1424	
RN1425	
RN1426	
RN1427	

RESTRICTIONS ON PRODUCT USE

000707EAA

- TOSHIBA is continually working to improve the quality and reliability of its products. Nevertheless, semiconductor devices in general can malfunction or fail due to their inherent electrical sensitivity and vulnerability to physical stress. It is the responsibility of the buyer, when utilizing TOSHIBA products, to comply with the standards of safety in making a safe design for the entire system, and to avoid situations in which a malfunction or failure of such TOSHIBA products could cause loss of human life, bodily injury or damage to property.
In developing your designs, please ensure that TOSHIBA products are used within specified operating ranges as set forth in the most recent TOSHIBA products specifications. Also, please keep in mind the precautions and conditions set forth in the "Handling Guide for Semiconductor Devices," or "TOSHIBA Semiconductor Reliability Handbook" etc..
- The TOSHIBA products listed in this document are intended for usage in general electronics applications (computer, personal equipment, office equipment, measuring equipment, industrial robotics, domestic appliances, etc.). These TOSHIBA products are neither intended nor warranted for usage in equipment that requires extraordinarily high quality and/or reliability or a malfunction or failure of which may cause loss of human life or bodily injury ("Unintended Usage"). Unintended Usage include atomic energy control instruments, airplane or spaceship instruments, transportation instruments, traffic signal instruments, combustion control instruments, medical instruments, all types of safety devices, etc.. Unintended Usage of TOSHIBA products listed in this document shall be made at the customer's own risk.
- The information contained herein is presented only as a guide for the applications of our products. No responsibility is assumed by TOSHIBA CORPORATION for any infringements of intellectual property or other rights of the third parties which may result from its use. No license is granted by implication or otherwise under any intellectual property or other rights of TOSHIBA CORPORATION or others.
- The information contained herein is subject to change without notice.

This datasheet has been download from:

www.datasheetcatalog.com

Datasheets for electronics components.