

Reflective Optical Sensor with Transistor Output

Description

The TCRT5000 has a compact construction where the emitting-light source and the detector are arranged in the same direction to sense the presence of an object by using the reflective IR beam from the object. The operating wavelength is 950 nm. The detector consists of a phototransistor.

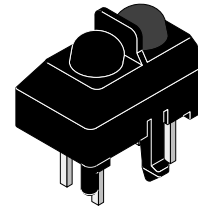

94 9442

Applications

- Position sensor for shaft encoder
- Detection of reflective material such as paper, IBM cards, magnetic tapes etc.
- Limit switch for mechanical motions in VCR
- General purpose – wherever the space is limited

Features

- Snap-in construction for PCB mounting
- Package height: 7 mm
- Plastic polycarbonate housing construction which prevents crosstalk
- L = long leads
- **Current Transfer Ratio (CTR)** of typical 10%

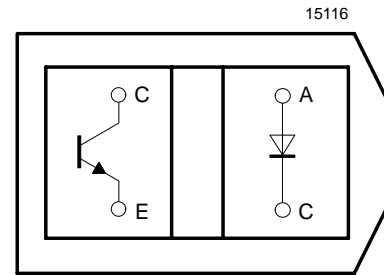

Top view

Order Instruction

Ordering Code	Sensing Distance	Remarks
TCRT5000	12 mm	Leads (3.5 mm)



Absolute Maximum Ratings

Input (Emitter)

Parameter	Test Conditions	Symbol	Value	Unit
Reverse voltage		V_R	5	V
Forward current		I_F	60	mA
Forward surge current	$t_p \leq 10 \mu A$	I_{FSM}	3	A
Power dissipation	$T_{amb} \leq 25^\circ C$	P_V	100	mW
Junction temperature		T_j	100	$^\circ C$

Output (Detector)

Parameter	Test Conditions	Symbol	Value	Unit
Collector emitter voltage		V_{CEO}	70	V
Emitter collector voltage		V_{ECO}	5	V
Collector current		I_C	100	mA
Power dissipation	$T_{amb} \leq 55^\circ C$	P_V	100	mW
Junction temperature		T_j	100	$^\circ C$

Sensor

Parameter	Test Conditions	Symbol	Value	Unit
Total power dissipation	$T_{amb} \leq 25^\circ C$	P_{tot}	200	mW
Operation temperature range		T_{amb}	-25 to +85	$^\circ C$
Storage temperature range		T_{stg}	-25 to +100	$^\circ C$
Soldering temperature	2 mm from case, $t \leq 10$ s	T_{sd}	260	$^\circ C$

Electrical Characteristics ($T_{amb} = 25^{\circ}\text{C}$)

Input (Emitter)

Parameter	Test Conditions	Symbol	Min.	Typ.	Max.	Unit
Forward voltage	$I_F = 60 \text{ mA}$	V_F		1.25	1.5	V
Junction capacitance	$V_R = 0 \text{ V}, f = 1 \text{ MHz}$	C_j		50		pF

Output (Detector)

Parameter	Test Conditions	Symbol	Min.	Typ.	Max.	Unit
Collector emitter voltage	$I_C = 1 \text{ mA}$	V_{CEO}	70			V
Emitter collector voltage	$I_E = 100 \mu\text{A}$	V_{ECO}	7			V
Collector dark current	$V_{CE} = 20 \text{ V}, I_F = 0, E = 0$	I_{CEO}		10	200	nA

Sensor

Parameter	Test Conditions	Symbol	Min.	Typ.	Max.	Unit
Collector current	$V_{CE} = 5 \text{ V}, I_F = 10 \text{ mA}, D = 12 \text{ mm}$	$I_C^{1,2)}$	0.5	1	2.1	mA
Collector emitter saturation voltage	$I_F = 10 \text{ mA}, I_C = 0.1 \text{ mA}, D = 12 \text{ mm}$	$V_{CEsat}^{1,2)}$			0.4	V

1) See test circuit

2) Test surface: Mirror (Mfr. Spindler a. Hoyer, Part No 340005)

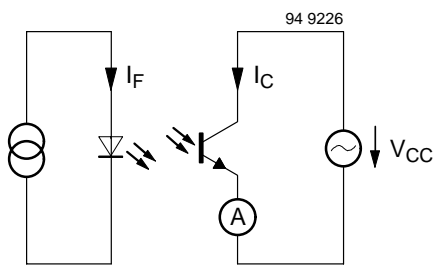

Figure 1. Test circuit

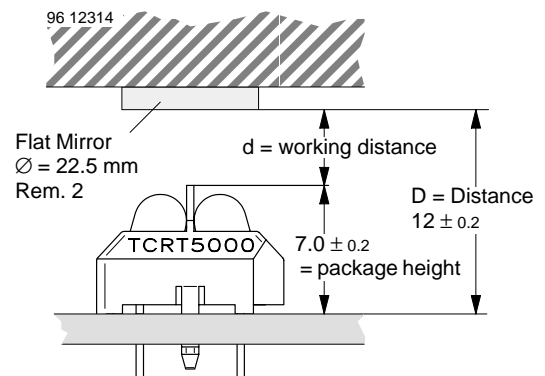

Figure 2. Test circuit

Typical Characteristics ($T_{amb} = 25^{\circ}C$, unless otherwise specified)

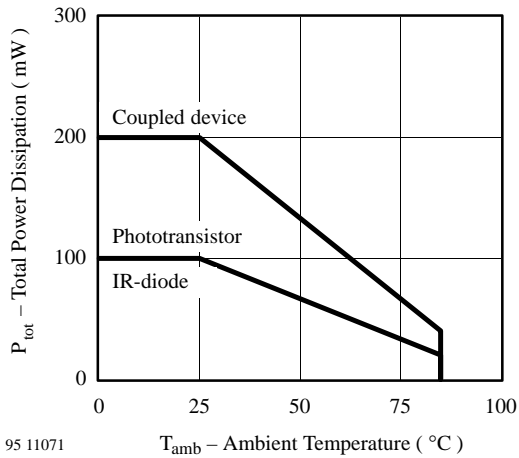

Figure 3. Total Power Dissipation vs. Ambient Temperature

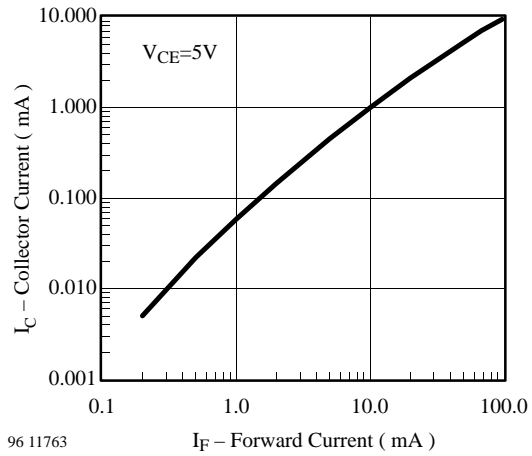

Figure 6. Collector Current vs. Forward Current

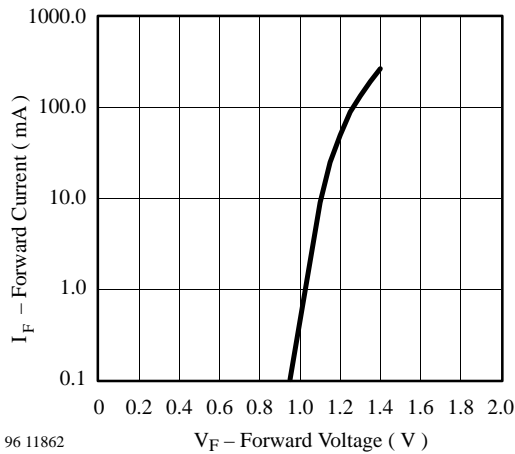

Figure 4. Forward Current vs. Forward Voltage

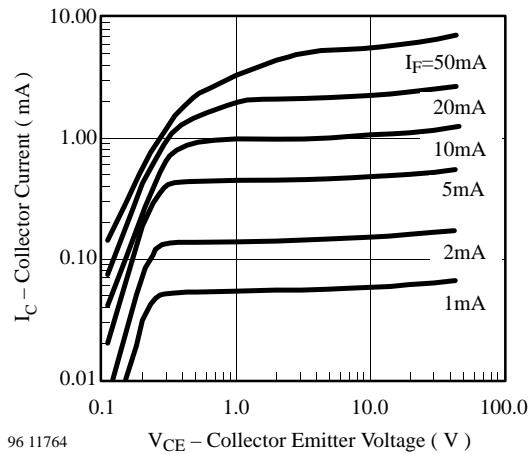

Figure 7. Collector Emitter Saturation Voltage vs. Collector Current

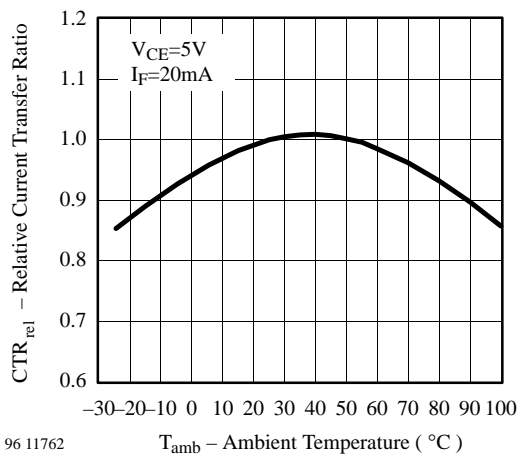

Figure 5. Rel. Current Transfer Ratio vs. Ambient Temp.

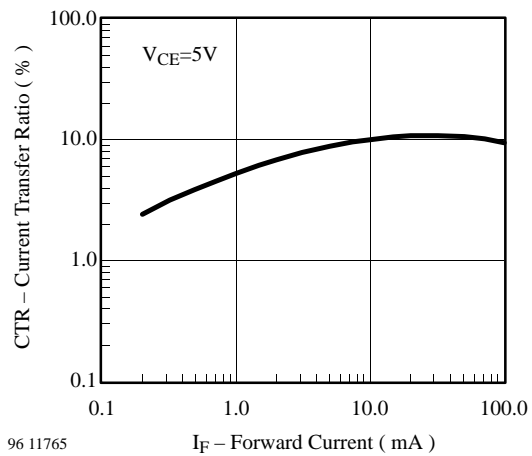

Figure 8. Current Transfer Ratio vs. Forward Current

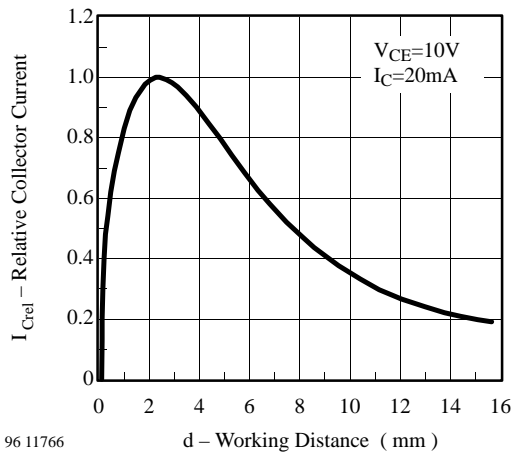
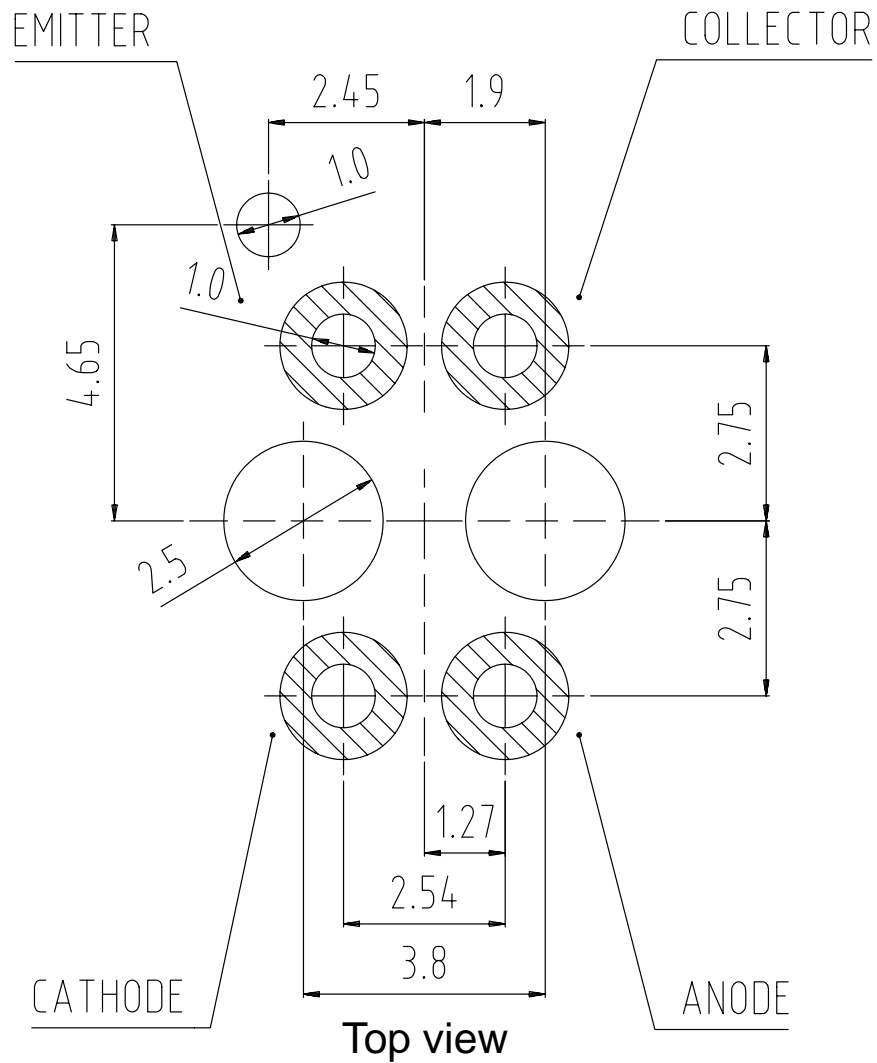

Figure 9. Relative Collector vs. Distance



Top view

Figure 10. Footprint

96 12371

Dimensions of TCRT5000 in mm

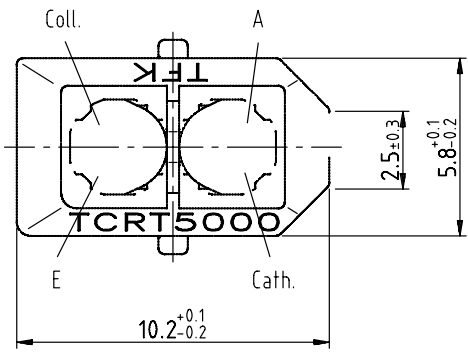
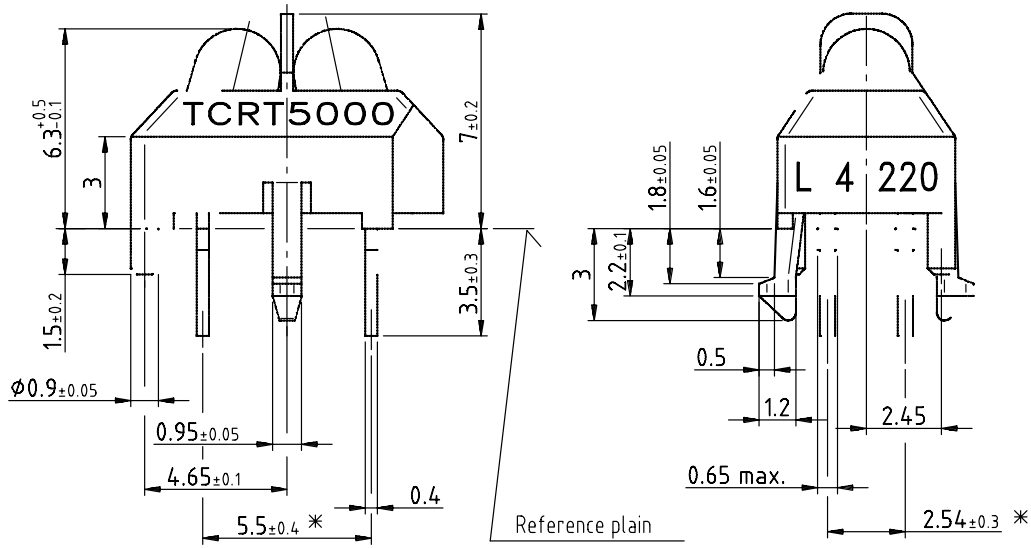

* Tolerances related to reference plain

weight: ca. 0.23g

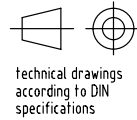

Footprint Top View

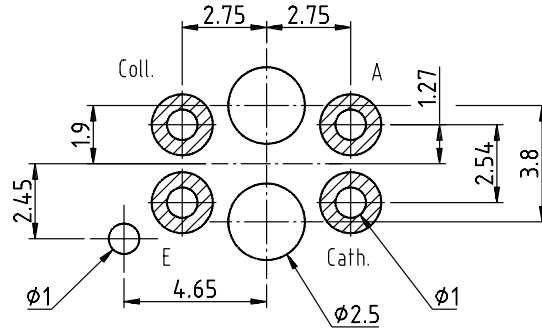

Drawing-No.: 6.550-5096.01-4

Issue: 3; 28.06.00

96 12073

Dimensions of TCRT5000L in mm

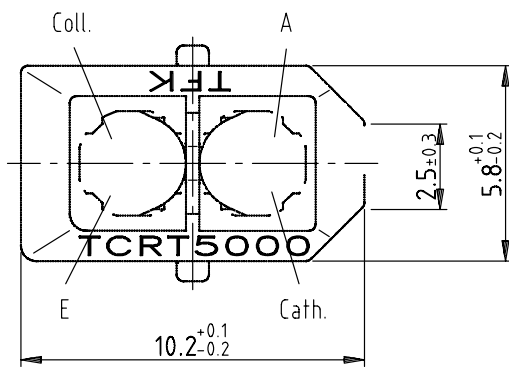
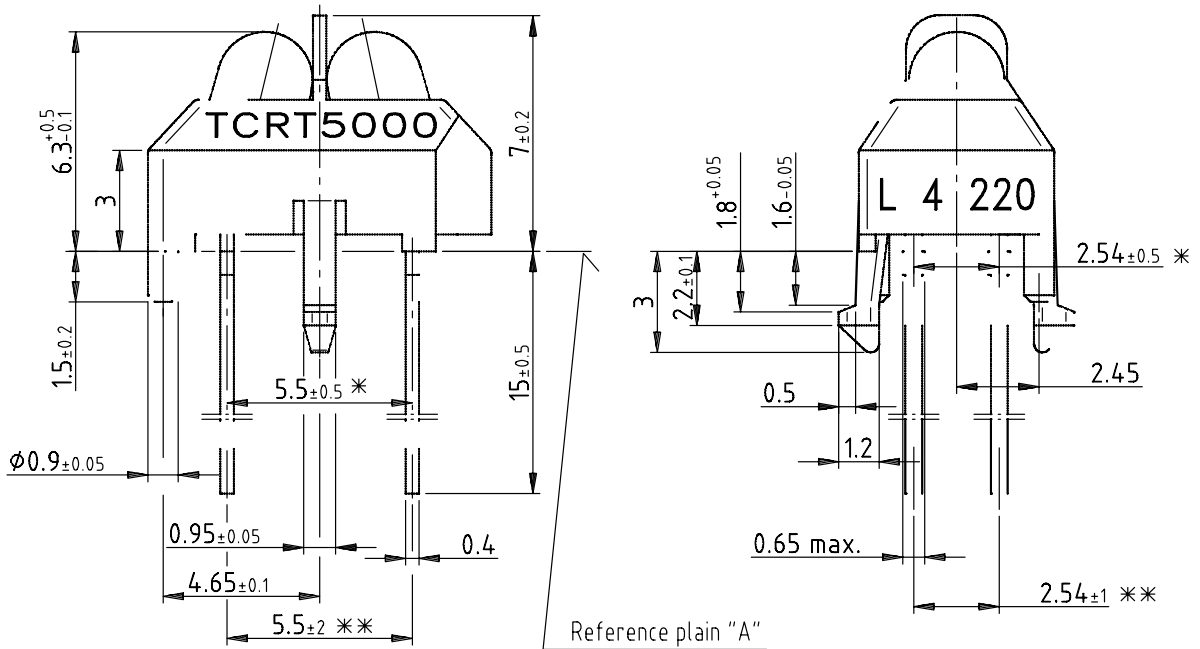

weight: ca. 0.23g

Drawing-No.: 6.550-5146.01-4

Issue: 3; 28.06.00

* Tolerances related to reference plain "A"

** Tolerances related on lead end

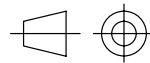

technical drawings according to DIN specifications

Footprint Top View

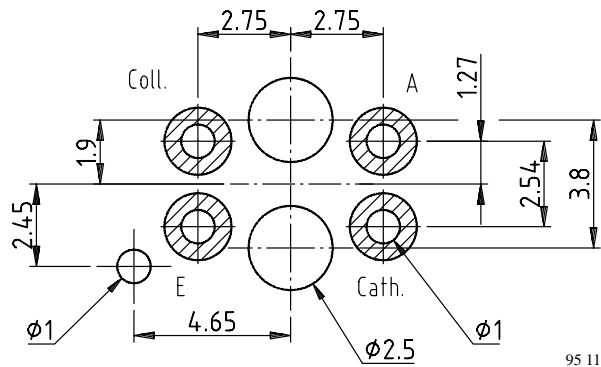

95 11267



Ozone Depleting Substances Policy Statement

It is the policy of **Vishay Semiconductor GmbH** to

1. Meet all present and future national and international statutory requirements.
2. Regularly and continuously improve the performance of our products, processes, distribution and operating systems with respect to their impact on the health and safety of our employees and the public, as well as their impact on the environment.

It is particular concern to control or eliminate releases of those substances into the atmosphere which are known as ozone depleting substances (ODSs).

The Montreal Protocol (1987) and its London Amendments (1990) intend to severely restrict the use of ODSs and forbid their use within the next ten years. Various national and international initiatives are pressing for an earlier ban on these substances.

Vishay Semiconductor GmbH has been able to use its policy of continuous improvements to eliminate the use of ODSs listed in the following documents.

1. Annex A, B and list of transitional substances of the Montreal Protocol and the London Amendments respectively
2. Class I and II ozone depleting substances in the Clean Air Act Amendments of 1990 by the Environmental Protection Agency (EPA) in the USA
3. Council Decision 88/540/EEC and 91/690/EEC Annex A, B and C (transitional substances) respectively.

Vishay Semiconductor GmbH can certify that our semiconductors are not manufactured with ozone depleting substances and do not contain such substances.