



深圳市鑫銘瓏精密電子有限公司

ShenZhen XinMingLong Precision Electronics Co., Ltd.

METAL FILM RESISTORS

(RN)

1/6、1/4、1/2、1、2、3W

RoHS COMPLIANT

LEAD FREE

APPROVAL SHEET
SPECIFICATION

承認圖

TO:

ATTN:

COMPANY NAME: ShenZhen XinMingLong Precision Electronics Co., Ltd.
深圳市鑫銘瓏精密電子有限公司

COUNTRY OF ORIGIN: TAIWAN

CHINA

PART NO. : RN???W xxxE B/C/D/F/G/J***

REMARK: ???=1/6、1/4、1/2、1、2、3(W)

xxx=Resistance (E=Ω)

B=±0.1%、C=±0.25%、D=±0.5%、F=±1%、G=±2%、J=±5%

***= BB、SM、SMF、SMK、U、UK、UKK、UB、UH、AVISERT、PANASERT、
TP26/52/57 (PACKAGE)

1/8W&1/16W were replaced by 1/6W

CUSTOMER APPROVE BY:
DATE:

DATE OF ISSUE	DRAWN BY	CHECKED BY
	MR. Qiu	MR. Guo

1. GENERAL PROVISIONS:

THIS RECOGNITION CHART APPLY TO TAIWAN OHM COATED INSULATED TYPE METAL FILM FIXED RESISTORS (RN) WITH CHARACTERISTICS.

2. STYLE: (PART NO.)

THE RESISTORS ARE CLASSIFIED ACCORDING TO THE FOLLOWING:

<u> RN </u>	<u> 1/6W </u>	<u> 100K Ω </u>	<u> J </u>	<u> BB </u>
CLASSIFICATION	POWER RATING	RESISTANCE	TOLERANCE	TYPE

3. SPECIFICATIONS:

POWER RANGE (W) AT70°C	1/6	1/4	1/2	1	2	3
TYPE	RN					
MAX. WORKING VOLTAGE (V)	150	250	350	500	500	500
MAX. OVERLOAD VOLTAGE (V)	300	500	700	1000	1000	1000
DIELECTRIC WITHSTANDING VOLTAGE (V)	150	250	350	500	500	500
AMBIENT TEMPERATURE RANGE	-55°C ~ 155°C					
RESISTANCE VALUE RANGE (Ω)	10 Ω ~ 1M Ω					
NOMINAL RESISTANCE TOLERANCE (B、C、D、F、G、J)	B±0.1%、C±0.25%&D±0.5%(E192), F±1%(E96), G±2%&J±5%(E24)					

Remark:Resistance Value had below 10 ohm & over 1M ohm available,please feel free inquire to us.

3-1. RATED POWER

YOU MAY GET A SATISFACTORY VOLTAGE DURING THE LOAD TEST WHEN THE AMBIENT TEMPERATURE IS AT70°C HOWEVER, AS THE TEMPERATURE RAISES ABOVE70°C, THE RATED LOAD DERATED AS SHOWN ON THE CHART BELOW.

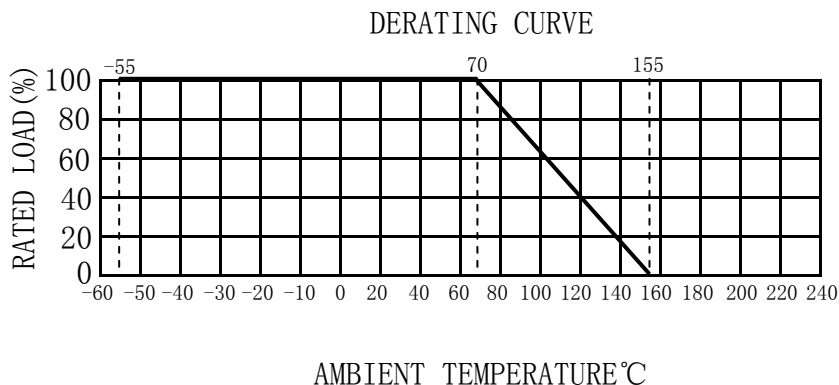

Remark:the ambient temperature is around the resistor surface anear,doer not room/ambient temperature.

3-2. RATED VOLTAGE

THE RATED CONTINUOUS WORKING VOLTAGE AND THE APPROXIMATE SINE-WAVE R. M. S. CONTINUOUS WORKING VOLTAGE AT COMMERCIAL LINE FREQUENCY , SHALL BE DETERMINED BY THE FOLLOWING.

FORMULA:

$$E = \sqrt{P \times R}$$

WHERE : E=RATED VOLTAGE (V)
 P=POWER RATING (W)
 R=NOMINAL RESISTANCE (Ω)

IN NO CASE THE MAXIMUM CONTINUOUS WORKING VOLTAGE SHALL BE EXCEEDED. IF THE VOLTAGE CALCULATED FROM THE ABOVE FORMULA IS HIGHER THAN THE RATED VOLTAGE, USE THE MAXIMUM WORKING VOLTAGE.

4. THE STRUCTURE OF THE RESISTORS

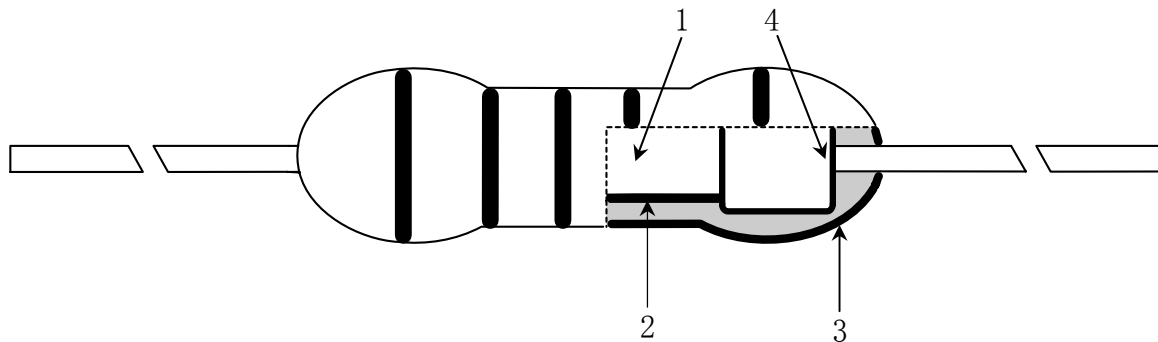

NO.	ITEM	MATERIAL	REMARK
1	RESISTOR BODY	CERAMIC	CERAMIC CORE
2	RESISTANCE	FILM	METAL FILM
3	COATING	EPOXY PAINT	COLOR:BLUE
4	LEADS (LEAD FREE)	IRON CAPS	CAPS:TINNED ELECTROPLATED SURFACE
		Cu WIRE (OF ELECTRICAL)	LEADS:TINNED ELECTROPLATED SURFACE
			CAPS AND Cu WIRE ARE WELDED TOGETHER

4. CHARACTERISTICS:

4-1. PERFORMANCE

TEST CHARACTERISTICS	REQUIREMENTS	TEST METHOD JIS C 5202
TEMPERATURE COEFFICIENT (PPM/°C)	BELOW $1\Omega \pm 300\text{PPM}/^\circ\text{C}$	5.2 ROOM TEMPERATURE +100°C
	$1\sim 10\Omega$ & $1\text{M}\sim 10\text{M}\Omega$	
	WITHIN $\pm 100\text{PPM}/^\circ\text{C}$	
	$10\Omega \sim 1\text{M}\Omega \pm 50\text{PPM}/^\circ\text{C}$	
SHORT-TIME OVERLOAD	WITHIN $\pm (0.5\% + 0.5\Omega)$	5.5 RATED V. x2.5 OR MAX. OVERLOAD V. for 5 Sec., whichever less
NOISE $\mu\text{V}/\text{V}$ (Db)	UNDER 10K 0.05 V/V 11K~100K 0.1 V/V OVER 110K 0.2 V/V	5.9
PULSE OVERLOAD	WITHIN $\pm (1\% + 0.5\Omega)$	5.8 NO LESS THAN 100Ω
RESISTANCE TO SOLDERING HEAT	WITHIN $(\pm 1\% + 0.5\Omega)$	6.4 DIP IN SOLDER POT OF $350\pm 10^\circ\text{C}$ FOR 3 SECONDS
SOLDERABILITY	OVER 75% OF COOPER WIRE COVERED WITH SOLDER	6.5 DIP IN SOLDER POT OF $235\pm 5^\circ\text{C}$ (WITHIN $3\pm 0.5\text{SEC.}$)
INSULATION RESISTANCE	OVER 1,000MΩ	5.6
DIELECTRIC WITHSTANDING VOLTAGE	NO EVIDENCE OF FLASHOVER OR BREAKDOWN	5.7
TEMPERATURE CYCLING	WITHIN $\pm (1\% + 0.5\Omega)$	JIS-C-5202 7.4 REPEAT FIVE TIMES
		TEMP. TIME
		1 $-55\pm 3^\circ\text{C}$ 30 Min.
		2 AMBIENT 10-15 Min.
3 $155\pm 3^\circ\text{C}$ 30 Min.		
4 AMBIENT 10-15 Min.		
LOAD LIFE IN HUMIDITY	WITHIN $\pm (1.5\% + 0.5\Omega)$	7.9 APPLY 1/10 RATED VOLTAGE FOR 90 Min., OFF FOR 30Min. AT $40\pm 2^\circ\text{C}$, 90~95%RH.
LOAD LIFE	WITHIN $\pm (2\% + 0.5\Omega)$	7.10 APPLY RATED VOLTAGE FOR 90Min., OFF FOR 30Min. AT 70°C
DC RESISTANCE	B $\pm 0.1\%$, C $\pm 0.25\%$, D $\pm 0.5\%$ F $\pm 1\%$, G $\pm 2\%$, J $\pm 5\%$	5.1

4-2. MECHANICAL CHARACTERISTICS.

ITEM	DIMENSION		TEST METHOD
Tensile Strength	2kgs.	5sec.	JIS-C-5202 6.1
Snapping Strength	360°	3times	JIS-C-5202 6.1
Bending Strength	0.25kgs.	2times	JIS-C-5202 6.1
Vibration	$\pm (0.5\%+0.5\Omega)$		6.3 Each 2 hour at 3 sides

5. TYPE AND DIMENSIONS.

5-1. RN...BB TYPE (BULK)



UNIT:mm

TYPE	$L\pm 1$	$D\pm 1$	$H\pm 3$	$d\pm 0.05$
RN1/6WxxxE J BB	3.3	1.8	28	0.40
RN1/4WxxxE J BB	6.3	2.5	28	0.48
RN1/2WxxxE J BB	9.5	3.3	28	0.50
RN1WxxxE J BB	11.5	4.5	28	0.70
RN2WxxxE J BB	15.5	5	28	0.70
RN3WxxxE J BB	17	6	28	0.70

5-2. RN...SM TYPE

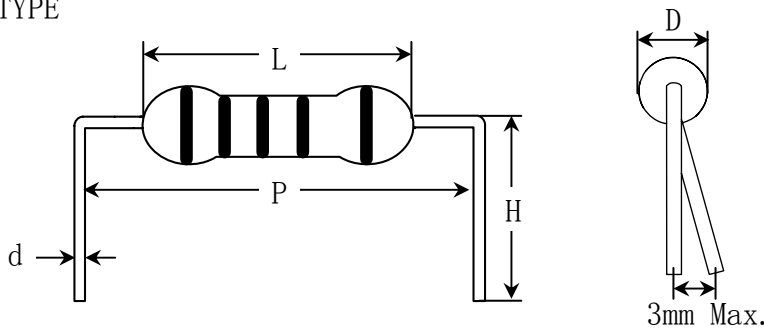

UNIT:mm

TYPE	$L\pm 1$	$D\pm 1$	$H\pm 3$	$P\pm 1$	$d\pm 0.05$
RN1/6WxxxE J SM	3.3	1.8	8	5	0.40
RN1/4WxxxE J SM	6.3	2.5	8	10	0.48
RN1/2WxxxE J SM	9.5	3.3	8	12.5/15	0.50
RN1WxxxE J SM	11.5	4.5	13	15/20	0.70
RN2WxxxE J SM	15.5	5	16	20	0.70

Design, Specifications are subject to change without notice. Ask factory for technical specifications before purchase and/or use.

Whenever a doubt about safety arises from this product, please inform us immediately for technical consultation without fail.

Ver: 2008 01 25

5-3. RN...SMF TYPE

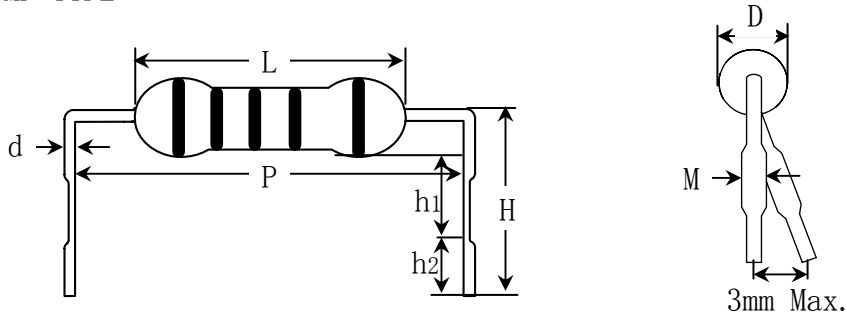

UNIT: mm

TYPE	L±1	D±1	H±3	P±1	h1±1	h2±1	d±0.05	M
RN1/2WxxxE J SMF	9.5	3.3	13	12.5/15	6.3	5	0.70	1.1-1.4
RN1WxxxE J SMF	11.5	4.5	13	15/20	5.7	5	0.70	1.1-1.4
RN2WxxxE J SMF	15.5	5	16	20	8.5	5	0.70	1.1-1.4

5-4. RN...SMK TYPE

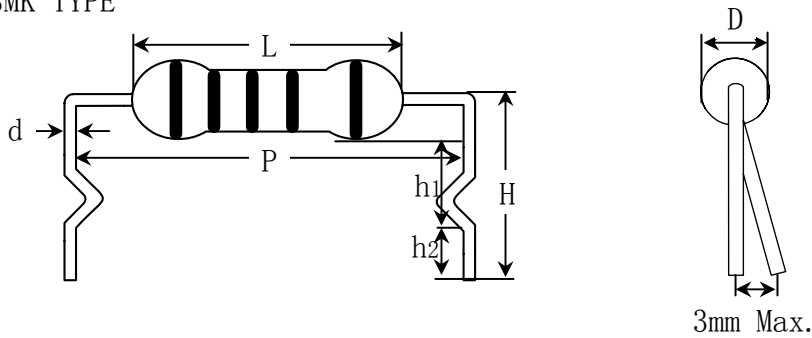

UNIT: mm

TYPE	L±1	D±1	H±2	P±1	h1±1	h2±1	d±0.05
RN1/4WxxxE J SMK	6.3	2.5	12	10	5.8	5	0.48
RN1/2WxxxE J SMK	9.5	3.3	13	12.5/15	6.3	5	0.50
RN1WxxxE J SMK	11.5	4.5	13	15/20	5.7	5	0.70
RN2WxxxE J SMK	15.5	5	16	20	8.3	5	0.70

Remark: H had different high available, please feel free inquire to us.

5-5. RN...U TYPE

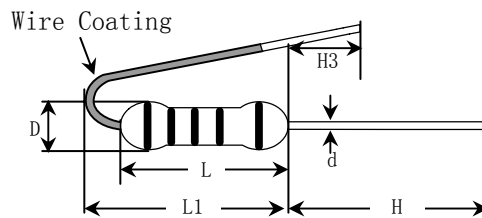

UNIT: mm

TYPE	L±1	L1±1	H±3	D±1	H3±3	d±0.05
RN1/6WxxxE J U	3.3	5.5Max.	28	1.8	20	0.40
RN1/4WxxxE J U	6.3	10Max.	28	2.5	14	0.48

Ver: 2008 01 25

METAL FILM RESISTORS(RN)

5-5. RN...U TYPE

UNIT:mm

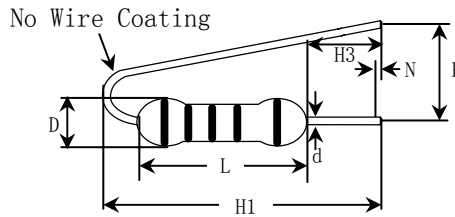

N Max.	2
P Min.	5

UNIT:mm

TYPE	$L \pm 1$	$D \pm 1$	$H1 \pm 3$	$H2 \pm 1$	$H3 \pm 3$	$d \pm 0.05$
RN1/2WxxxE J U	9.5	3.5	17	—	8	0.50
RN1WxxxE J U	11.5	4.5	24	—	8	0.70
RN2WxxxE J U	15.5	5.5	27	—	8	0.70

5-6. RN...UK TYPE

UNIT:mm

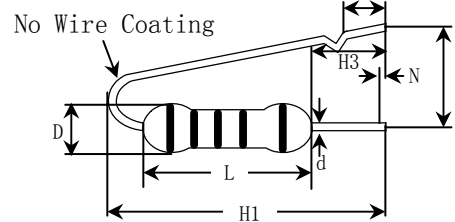

N Max.	2
P Min.	5

UNIT:mm

TYPE	$L \pm 1$	$D \pm 1$	$H1 \pm 3$	$H2 \pm 1$	$H3 \pm 3$	$d \pm 0.05$
RN1/2WxxxE J UK	9.5	3.5	17	5	8	0.50
RN1WxxxE J UK	11.5	4.5	20	5	8	0.70
RN2WxxxE J UK	15.5	5.5	24	5	8	0.70

5-7. RN...UKK TYPE

UNIT:mm

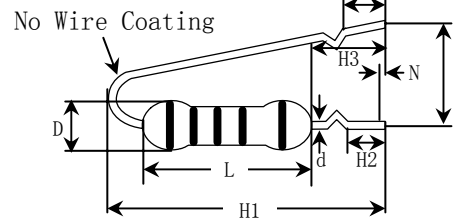

N Max.	2
P Min.	5

TYPE	$L \pm 1$	$D \pm 1$	$H1 \pm 3$	$H2 \pm 1$	$H3 \pm 3$	$d \pm 0.05$
RN1/2WxxxE J UKK	9.5	3.5	17	5	8	0.50
RN1WxxxE J UKK	11.5	4.5	20	5	8	0.70
RN2WxxxE J UKK	15.5	5.5	24	5	8	0.70

5-8. RN...UB TYPE

UNIT:mm

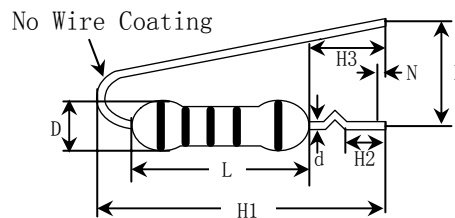

N Max.	2
P Min.	5

TYPE	$L \pm 1$	$D \pm 1$	$H1 \pm 3$	$H2 \pm 1$	$H3 \pm 3$	$d \pm 0.05$
RN1/2WxxxE J UB	9.5	3.5	19	5	8	0.50
RN1WxxxE J UB	11.5	4.5	22	5	8	0.70
RN2WxxxE J UB	15.5	5.5	26	5	8	0.70

5-9. RN...UH TYPE

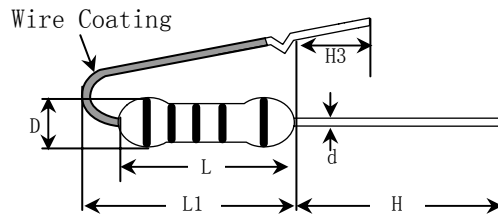

UNIT:mm

TYPE	$L \pm 1$	L1	$H \pm 3$	$D \pm 1$	$H3 \pm 3$	$d \pm 0.05$
RN1/4WxxxE J UH	6.3	10Max.	28	2.5	14	0.48

5-10. RN...PANASERT TYPE

This specification is applicable to RN/0.25(1/4W) of Metal Film Fixed Resistors.

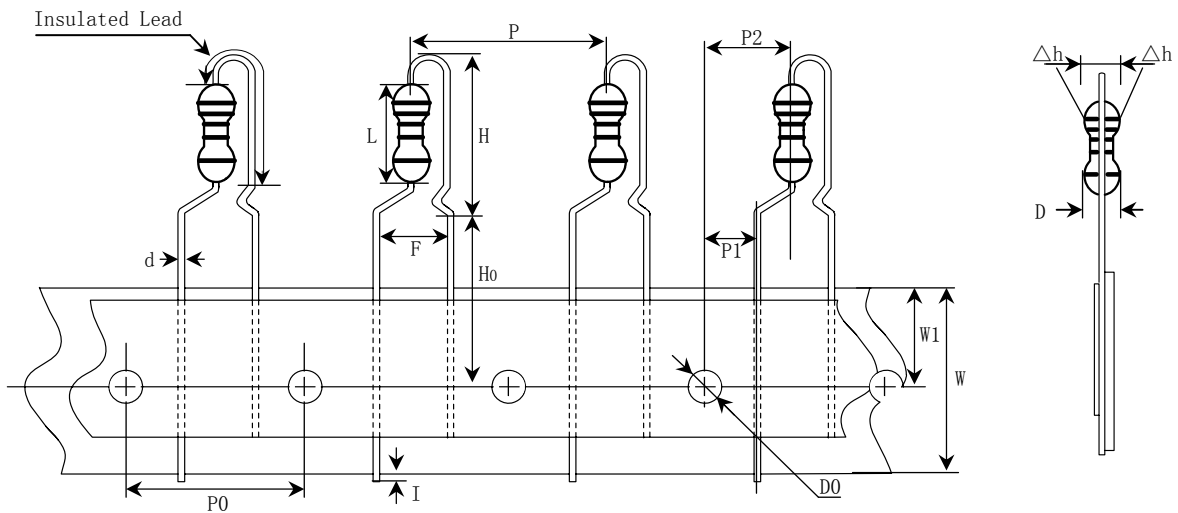

D	2.5Max.
L	6.5Max.
H	12Max.
d	0.6 ± 0.05
P	12.7 ± 1
P0	12.7 ± 0.3
P1	3.85 ± 0.7
P2	6.35 ± 1.3
F	5 ± 0.8
Δh	0 ± 2
W	18 ± 1
W1	9 ± 0.5
H0	16 ± 0.5
D0	4 ± 0.2
I	1.0Max.
t	0.5 ± 0.2

UNIT:mm

Ver: 2008 01 25

5-11. RN...AVISERT TYPE

This specification is applicable to RN1/6W & 1/4W of Metal Film Fixed Resistors.

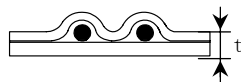
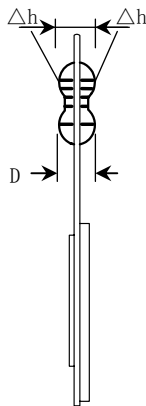
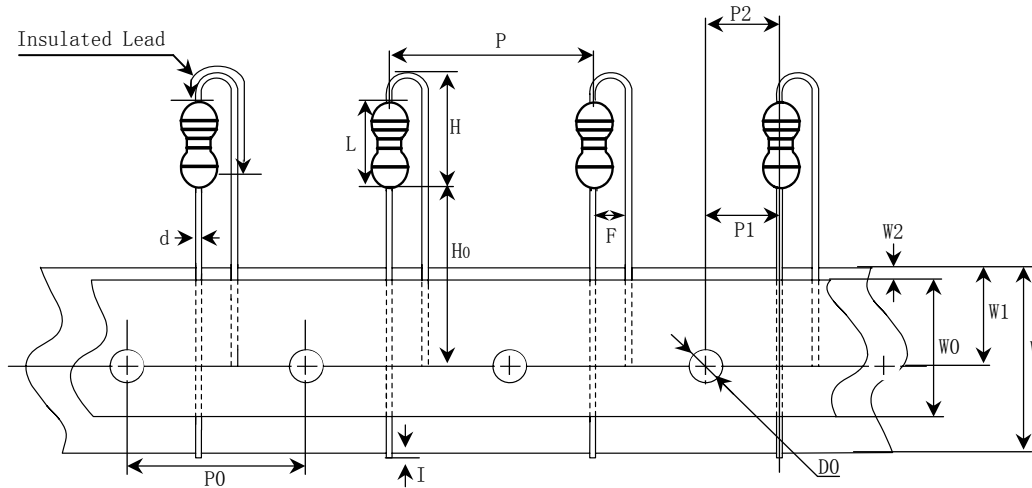

D	1/6W:1.8Max. 1/4W:2.5Max.
L	1/6W:3.2Max. 1/4W:6.5Max.
H	1/6W:7.0Max. 1/4W:10Max.
d	1/6W:0.5±0.05 1/4W:0.6±0.05
P	12.7±1
P0	12.7±0.3
P1	5.1±0.5
F	1/6W:2.5±1 1/4W:5±1
Δh	0±1
W	18±1
W0	12.5Min
W1	9±0.5
W2	3Max.
H0	16.5Max.
D0	4±0.3
I	1.0Max.
t	0.5±0.2

UNIT:mm

5-12. RN...TP26/52/57 TYPE (Taping 26/52/57mm in Box)

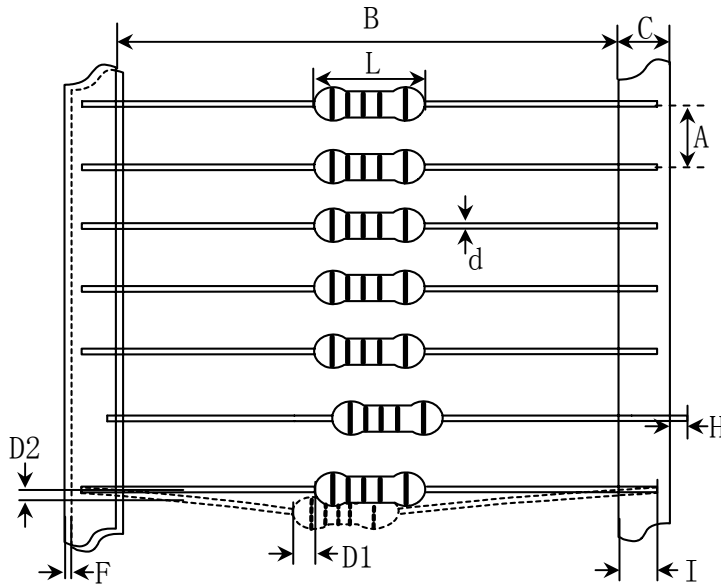

UNIT:mm

C	6±0.5
F	0.5Max.
I	3.2Min
H	0

UNIT:mm

TYPE	A±0.5	B±1	D1	D2	L±1	d±0.05
RN1/6WxxxE J TP26	5	26±1.5	0.8Max.	1.1Max.	3.3	0.40
RN1/6WxxxE J TP52	5	52	0.8Max.	1.1Max.	3.3	0.40
RN1/4WxxxE J TP26	5	26±1.5	0.8Max.	1.1Max.	6.3	0.48
RN1/4WxxxE J TP52	5	52	0.8Max.	1.1Max.	6.3	0.48
RN1/2WxxxE J TP52	5	52	0.8Max.	1.1Max.	9.5	0.50
RN1WxxxE J TP52	5	52	0.8Max.	1.1Max.	11.5	0.70
RN2WxxxE J TP57	10	57	0.8Max.	1.1Max.	15.5	0.70
RN3WxxxE J TP57	10	57	0.9Max.	1.2Max.	17	0.70

6. Taping 26/52/57mm Packing Box Specifications

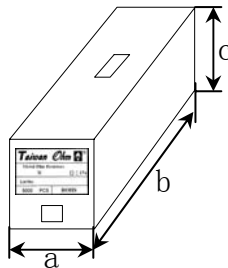

UNIT:mm

Taiwan Ohm Part No.	Standard Quantity	a	b	c
RN1/6WxxxE J TP26	5000pcs	49	254	70
RN1/6WxxxE J TP52	5000pcs	75	254	70
RN1/4WxxxE J TP26	5000pcs	49	254	105
RN1/4WxxxE J TP52	5000pcs	75	254	105
RN1/2WxxxE J TP52	2000pcs	75	254	105
RN1WxxxE J TP52	1000pcs	75	254	115
RN2WxxxE J TP57	1000pcs	75	254	105

Ver: 2008 01 25

7. INDICATION

THE RESISTANCE VALUE AND TOLERANCE OF THE RESISTORS ARE INDICATED WITH THE COLOR CODE, REFER TO JIS-C-0802.

COLOR	1 ST VALUE	2 ND VALUE	3 TH VALUE	MULTIPLIER	TOLERANCE
BLACK	0	0	0	10^0	
BROWN	1	1	1	10^1	± 1% (F)
RED	2	2	2	10^2	± 2% (G)
ORANGE	3	3	3	10^3	
YELLOW	4	4	4	10^4	
GREEN	5	5	5	10^5	± 0. 5% (D)
BLUE	6	6	6	10^6	± 0. 25% (C)
VIOLET	7	7	7	—	± 0. 1% (B)
GREY	8	8	8	—	
WHITE	9	9	9	—	
GOLD	—	—	—	10^{-1}	± 5% (J)
SILVER	—	—	—	10^{-2}	

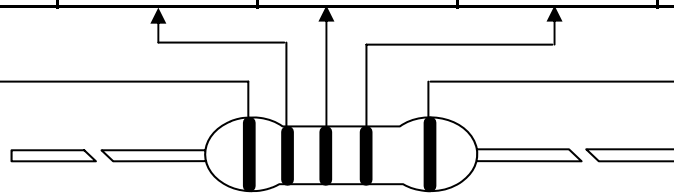

Design, Specifications are subject to change without notice. Ask factory for technical specifications before purchase and/or use.

Whenever a doubt about safety arises from this product, please inform us immediately for technical consultation without fail.

Ver: 2008 01 25

8. RoHS Instructions:

According to the EU RoHS requirements, our products are transported to EU must comply the below dangerous components content standards shown in the table from 1st Jan 2005.

RoHS Compliance Statement

We Taiwan Ohm are fully aware of reducing the environmental impact of our products RN series. Resistors as mentioned below part numbers accordance with EU directive 2002/95/EC.

Part numbers:RN***

The above mentioned part numbers can meet RoHS standard as below table:

Metal Film Resistors (Through-hole)	
1. Cadmium(Cd)	: < 100ppm
2. Lead(Pb)	: < 1000ppm
3. Mercury(Hg)	: < 1000ppm
4. Hexavalent Chormium(Cr6+)	: < 1000ppm
5. Polybrominated Blphenyls(PBBs)	: < 1000ppm
6. Polybrominated Diphenylethers(PBDEs)	: < 1000ppm

8-1. RoHS Marking Control



Our packing outside box had RoHS marking.

Remark:

We had control all main Raw Material to must comply RoHS & had Testing Reports support. If you want to have update Testing Reports, please feel free to ask our factory. All Testing Reports had effective one year.

Design, Specifications are subject to change without notice. Ask factory for technical specifications before purchase and/or use.

Whenever a doubt about safety arises from this product, please inform us immediately for technical consultation without fail.