

## Universal Controller IC for the 2-Phase Stepping Motor Drive PMM8713PT

### Outline

The universal controller "PMM8713PT" is the gate array IC (HIC) to control the 2-phase stepping motor drive. This product has been developed for the purpose to further simplify 2-phase stepping motor use, as combined only with switching elements or power hybrid ICs to configure a 2-phase stepping motor driver.

### Characteristics

- Universal controller : The following 3 types of energization mode can be selected by switching at the energization mode switching terminal 1EX / 1-2EX / 2EX
- Source voltage :  $V_{CC}=4.5\sim 5.5V$
- High output current : 24mA min (sink, source)
- High noise margin : Schmitt trigger circuit is incorporated for the all input terminals.
- 2 types of pulse input : 2 input mode (CW, CCW input mode)  
1 input mode (CK, U/D input mode)
- Excited status verification monitor : Outputs the monitor signal of the controller status.

### Maximum Rating (Ta=25°C)

Item	Symbol	Rating	Unit
Source voltage	$V_{CC}$	-0.3~7	V
Output current ø	"H" level $I_{OH\ \emptyset}$	-35	mA
	"L" level $I_{OL\ \emptyset}$	35	
Output current Co,Em	"H" level $I_{OH}$		µA
	"L" level $I_{OL}$		
Input voltage	$V_{IN}$	-0.3~ $V_{CC}+0.3$	V
Input current	$I_{IN}$	±10	mA
Operating current	$T_{opr}$	-20~85	°C
Conservation temperature		$T_{stg}$	-40~125 °C

### Recommended Operating Conditions (Ta=20~85°C)

Item	Symbol	Rating			Unit
		Min.	Standard	Max.	
Source voltage	$V_{CC}$	4.5	-	5.5	V
Output current ø	"H" level $I_{OH\ \emptyset}$	-24	-	-	mA
	"L" level $I_{OL\ \emptyset}$	24	-	-	
Output current Co,Em,Zo	"H" level $I_{OH}$	-2	-	-	mA
	"L" level $I_{OL}$	2	-	-	
Input voltage	$V_{IN}$	0	-	$V_{CC}$	V

## Dimensions (Unit: mm)

Pin No.	Name	Function
1.	Cu	Input pulse UP clock input
2.	Cd	Input pulse DOWN clock input
3.	Ck	Input pulse clock input
4.	U/D	Rotation direction conversion
5.	Ea	energization mode switching input
6.	Eb	energization mode switching input
7.	ec	energization mode switching input
8.	Vss	GND
9.	R	Reset input
10.	ø4	ø4 output
11.	ø3	ø3 output
12.	ø2	ø2 output
13.	ø1	ø1 output
14.	EM	energization monitor output
15.	Co	Input pulse monitor output
16.	Vcc	4.5~5.5V

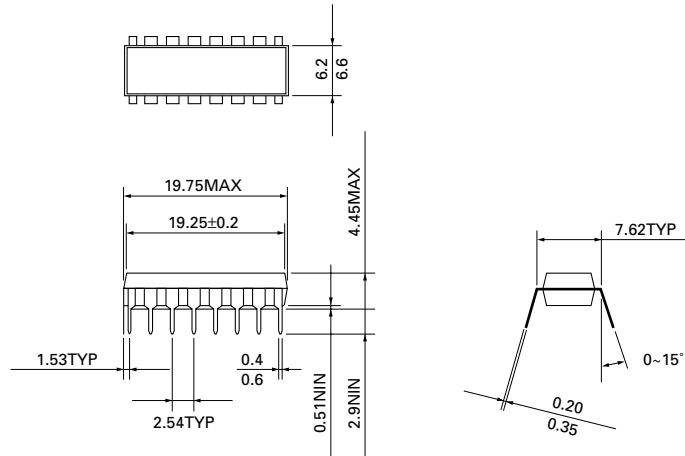

## Electrical Characteristics

### Direct current characteristics (Ta=-20~85°C)

Item	Symbol	Vcc [V]	Condition	Standard value			Unit	
				Min.	Standard	Max.		
Input voltage	"H" level	V <sub>IH</sub>	5	—	3.5	—	—	V
	"L" level	V <sub>IL</sub>	5	—	—	—	1.5	
Output voltage	"H" level	V <sub>OH</sub>	5	V <sub>H</sub> = 5V V <sub>L</sub> = 0V I <sub>OH</sub> = 0	4.9	—	—	V
	"L" level	V <sub>OL</sub>	5	V <sub>H</sub> = 5V V <sub>L</sub> = 0V I <sub>OH</sub> = 0	—	—	0.1	
Output current ø1~ø4	"H" level	I <sub>OH</sub>	5	V <sub>H</sub> = 5V V <sub>L</sub> = 0V V <sub>OUT</sub> = 2.4V	-24	—	—	mA
	"L" level	I <sub>OL</sub>	5	V <sub>H</sub> = 5V V <sub>L</sub> = 0V V <sub>OUT</sub> = 0.4V	24	—	—	
Output current Co,EM	"H" level	I <sub>OH</sub>	5	V <sub>H</sub> = 5V V <sub>L</sub> = 0V V <sub>OUT</sub> = 2.4V	-2	—	—	mA
	"L" level	I <sub>OL</sub>	5	V <sub>H</sub> = 5V V <sub>L</sub> = 0V V <sub>OUT</sub> = 0.4V	2	—	—	
Input current	I	5	—	—	—	10	—	µA
Static current consumption	I <sub>CC</sub>	5	V <sub>H</sub> = 5V V <sub>L</sub> = 0V	—	—	1	—	mA

### Switching characteristics (Ta=20~85°C)

Item	Symbol	Vcc [V]a	Condition	Standard value			Unit
				Min.	Standard	Max.	
Max. clock frequency	f <sub>MAX</sub>	5	tr=tf=20ns,CL=50pF	1	—	—	MHz
Min. width of clock pulse	t <sub>WL</sub> ,t <sub>WH</sub>	5	tr=tf=20ns,CL=50pF	—	—	500	ns
Min. width of reset pulse	t <sub>WR</sub>	5	tr=tf=20ns,CL=50pF	—	—	1000	ns
Time delay (from clock input to ø output)	t <sub>pd</sub>	5	tr=tf=20ns,CL=50pF	—	—	2000	ns
Set time	t <sub>SET</sub>	5	tr=tf=20ns,CL=50pF	0	—	—	ns
Holding time	t <sub>HOLD</sub>	5	tr=tf=20ns,CL=50pF	250	—	—	ns

## Electrical Characteristics

### Measured waveforms on switching time scale

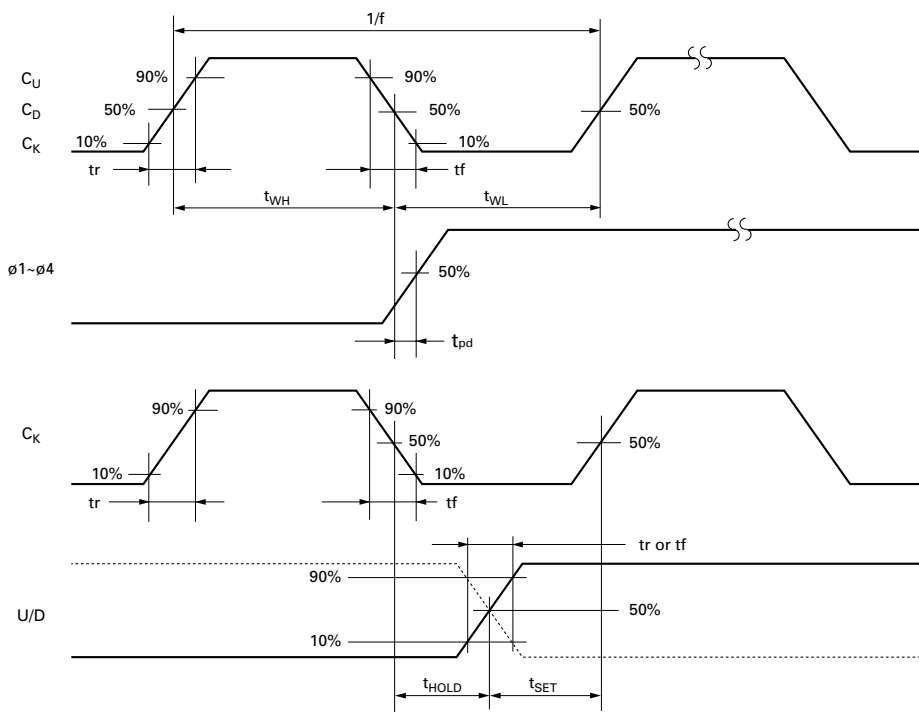

## Function Table

### Input modes and rotation direction

Input mode	Input				Rotation direction
	C <sub>u</sub>	C <sub>D</sub>	C <sub>K</sub>	U/D	
2 input mode (CW,CCW)	$\overline{L}$	L	L	L	CW
	L	$\overline{L}$	L	L	CCW
1 input mode (CK, U/D)	L	L	$\overline{L}$	H	CW
	L	L	$\overline{L}$	L	CCW

### Energization modes

Excitation mode	Input			
	$\overline{R}$	E <sub>A</sub>	E <sub>B</sub>	ø <sub>c</sub>
1 EX	H	H	L	H
1-2EX	H	H	H	H
2 EX	H	L	L	H

## Energization Sequence

### 1EX

Pulse Phase	0 (Reset)	1	2	3	4
ø1	1	0	0	0	1
ø2	0	1	0	0	0
ø3	0	0	1	0	0
ø4	0	0	0	1	0
E <sub>M</sub>	0	0	0	0	0
UP	→				
DOWN	←				

### 2EX

Pulse Phase	0 (Reset)	1	2	3	4
ø1	1	1	0	0	1
ø2	0	1	1	0	0
ø3	0	0	1	1	0
ø4	1	0	0	1	1
E <sub>M</sub>	1	1	1	1	1
UP	→				
DOWN	←				

### 1-2EX

Pulse Phase	0 (Reset)	1	2	3	4	5	6	7	8
ø1	1	1	1	0	0	0	0	0	1
ø2	0	0	1	1	1	0	0	0	0
ø3	0	0	0	0	1	1	1	0	0
ø4	1	0	0	0	0	0	1	1	1
E <sub>M</sub>	1	0	1	0	1	0	1	0	1
UP	→								
DOWN	←								

• Reset after changing the energization mode.

# Input Pulse Monitor

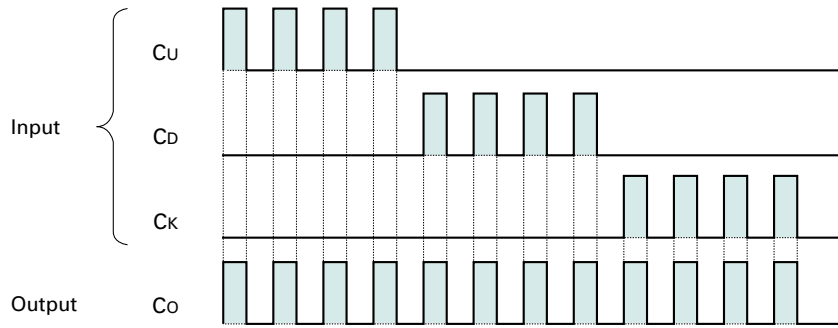

# Example of Application Circuit (Bipolar wiring motor)

- Combined with the power hybrid IC

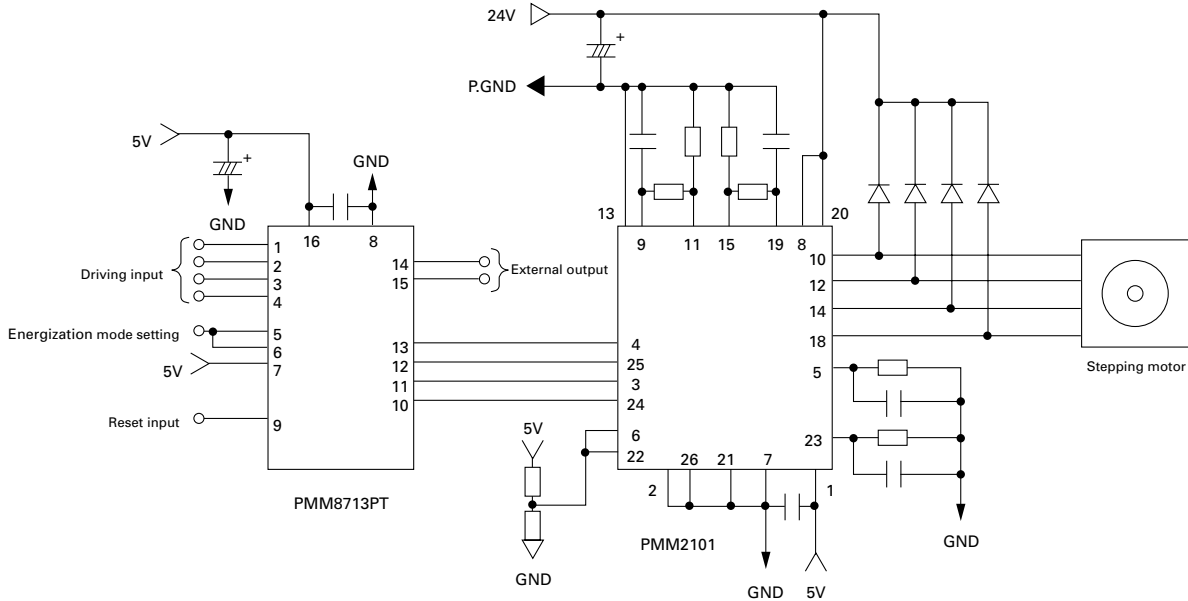

### Energization mode setting

Pin No.	Terminal symbol	Input level	Motor operation
5,6	E <sub>A</sub> ,E <sub>B</sub>	H	1-2EX
		L	2EX

- The normal initial reset may not be performed during unstable VCC after turning the power ON. For reliable resetting, hold the R terminal (9-pin) at the "L" level till the VCC becomes stable.

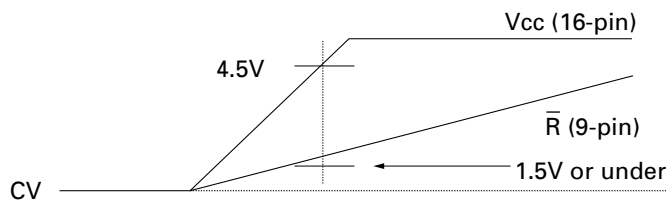

- Power hybrid IC: Refer to page 146 for the PMM2101 specifications.
- Refer to the PMM8713PT Operation Manual for other application circuit examples.