



OPERATING INSTRUCTIONS



<Main features>

TOP/FLOOR optional function

External contact temp. deviation, pre-heat time controllable

1 Caution for Your Safety

Please read this instruction carefully before using this controller.

※ The Manual's information & specification can be changeable to improve its quality without any notification

⚠ Safety

Please read the operating manual throughly before putting the device into operation

We will not assume any responsibility for damage to assets or persons caused by improper handling or failure to observe the safety instructions or hazard warnings

For safety and licensing reasons, unauthorized conversion and/or modification of the device is not permitted.

Do not exceed the maximum permissible current – in case of higher loads, use a contactor of adequate power. Make sure that the supplied voltage matches the values specified for the instrument.

The device must be adequately protected from water and dust as per the application and must be accessible via the use of appropriate tools

The device must not be exposed to extreme temperature, sunlight, strong vibrations or high levels of humidity.

Operation or installation is not permitted under unfavorable ambient conditions such as wetness or excessive induction loads or solenoid and dust, combustible gases,

vapors or solvents, especially high-frequency noise

Avoid operation or installation close to high-frequency fields such as welding devices, sewing machines, wireless transmitter, radio systems, SCR controller, etc

Do not install the sensor cable nearby signal cable, power cable, load cable,

Please use the shield cable when the sensor cable's lengthen, however do not make it too much longer

Please use the sensor cable without any cutting or flaw, blemish.

The device is not a toy and should be kept away from children

Installation work must only be carried out by suitably qualified personnel who are familiar

with the hazards involved and with the relevant regulations. You shouldn't tinker with anything or the product may not be opened or disassembled unless you know what you're doing. Please ask us about this questioning

⚠ Danger

■ Caution, Danger of electric shock

- Electric shock - Do not touch AC board during power on because of electric shock.
- Pls intercept the input power surely when turn the power on because of electric shock.

⚠ Safety

1. Pls use this item after installing the duplex safety device in which is applied at dangerous factors such as serious human injury or serious damages of property & important machine because this item is not designed as safety device.
2. Do not check or repair when it is power on
3. Pls check the terminal number before connecting power supply
4. Do not disassemble or open, remodel, repair without any permission.

2 Technical data

Model	J - N900
Operating voltage	100~240VAC 50/60Hz
Capable Volt. range	Power supply's 90% ~ 110%
Power consumption	Approx. below 16 VA
Display mode	7Segment LED Display(red color) [LED : red color]
Input sensor	CA(K)
Control type	ON/OFF
Control range	-30°C ~ 300°C
Control output	RELAY JS1-12V-F Max(DC 24V/ AC 125V)
	RELAY JQ1-12V-F Max(DC/10V/AC250V)
	RELAY JQ1A-12V-F Max(DC/10V/AC250V)
Ambient Temp.	0°C to 50°C

3 Controls and indicators

■ Part name

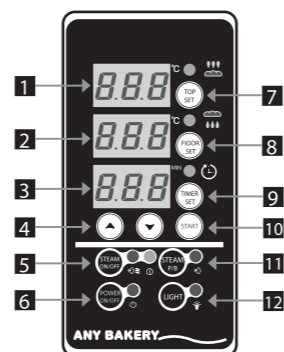

- 1 FND : TOP Current temp.
- 2 FND : FLOOR Current temp.
- 3 FND : TIMER Remaining time
- 4 UP/DOWN button
- 5 STEAM : External steamer operation/operation alarm LED display
- 6 Power : ON/OFF
- 7 TOP SET : Temperature setting/temperature correction/pre-heating temperature controlling/temperature max&min point setting
- 8 FLOOR SET : Temp. setting/temp.correction pre-heating temp. controlling
- 9 TIMER SET : TIME setting/steaming time setting pre-heating time setting/alarm time setting
- 10 TIMER start/end
- 11 STEAM : STEAMING
- 12 LIGHT : LAMP ON/OFF

4 Setup mode

■ TOP/FLOOR Temp. setup

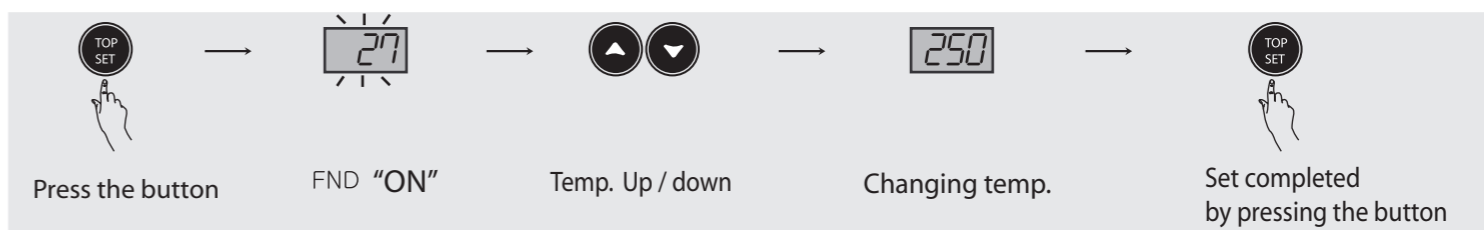

■ TOP/FLOOR programming

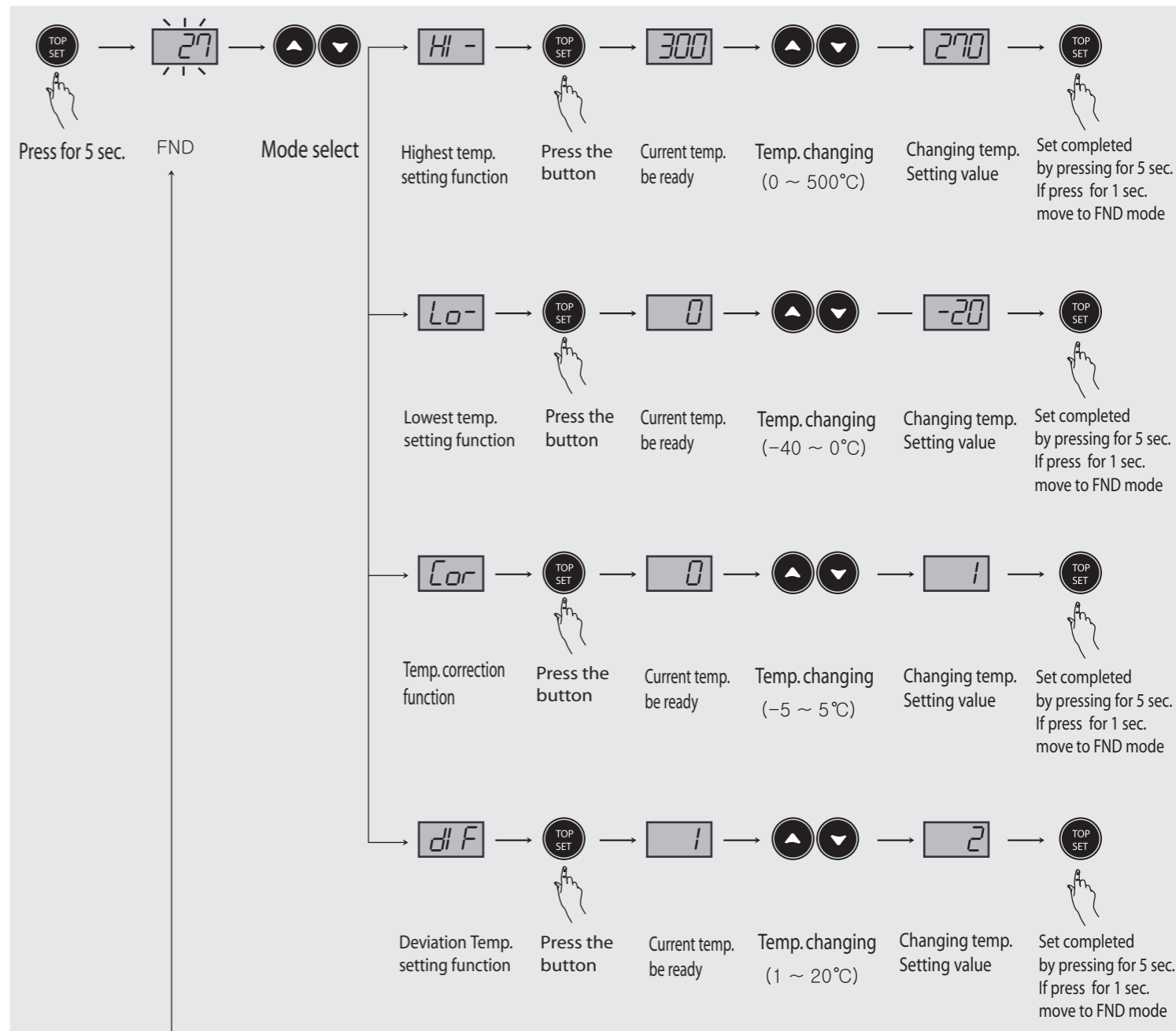

※ TOP/FLOOR settings are the same.

※ Without the input of the settings for about 30 seconds to return automatically to the initial detail settings.

※ Setting on(or changing) in a row when pressing the key to a fast increase(decrease).

5 TIMER setting

■ Timer setting details

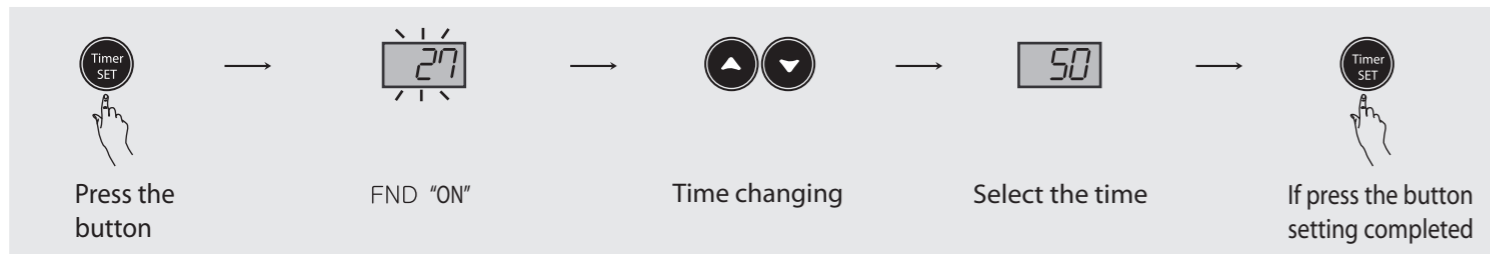

■ Program setting details

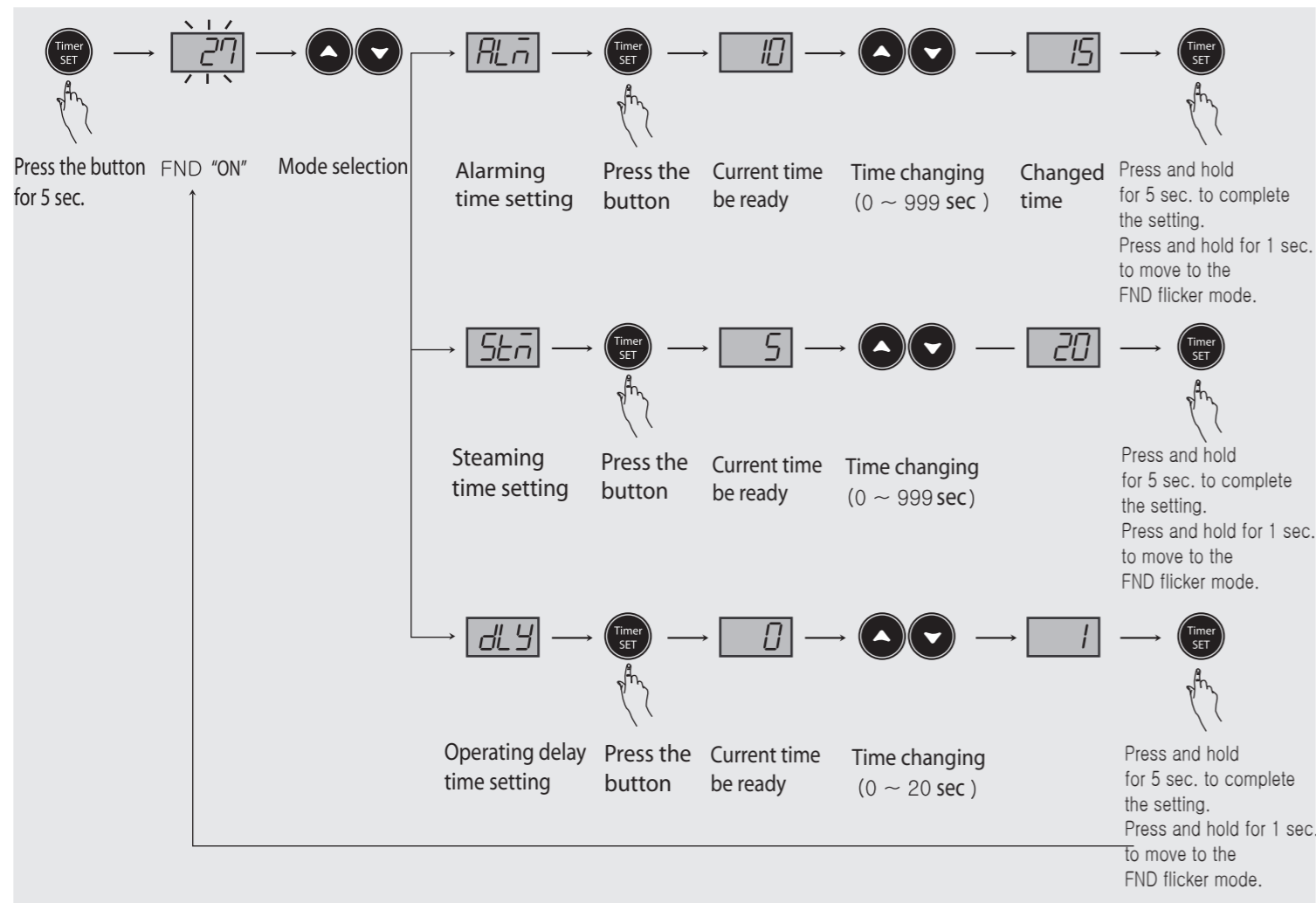

- ※ The system will automatically return to the Initial Setup Screen if there is no key entry for 30 sec. during setting.
- ※ Setup values increases (decreases) rapidly when the ▲ or ▼ key is pressed down during setting(change).

6 External size & Panel dimension

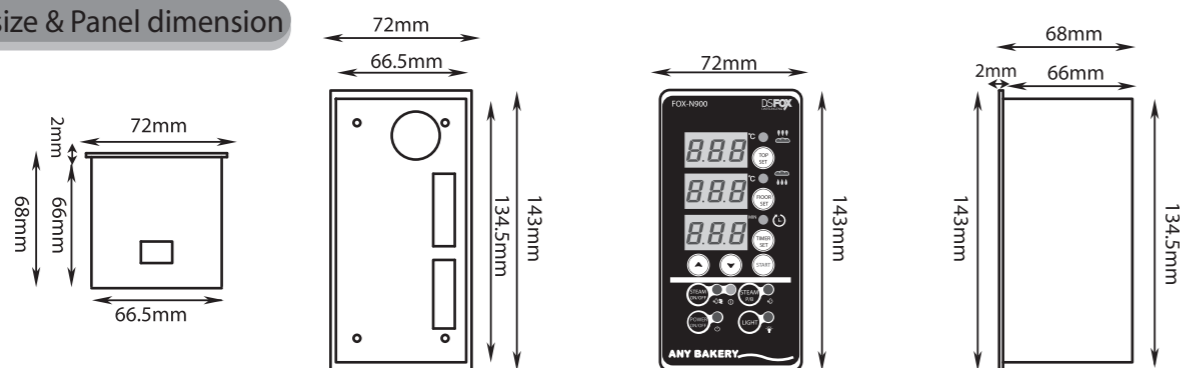

7 Description of Functions in Detail

■ TOP/FLOOR Program Function

HI - : To set the highest temperature
This function is used to allow temperature changes within the set temperature by the last user. If the last user had set the highest temperature to 250, this is the highest temperature the equipment will reach. The highest temperature can be set between 0~500°C.
e.g) If the HI value is set to 250°C, temperature will not rise above 250°C.

Lo- : To set the lowest temperature
This function is used to allow temperature changes within the set temperature by the last user. If the last user had set the lowest temperature to -10°C, this is the lowest temperature the equipment will reach. The lowest temperature can be set between -40~0°C.
e.g) If the LOW value is set to -10°C, temperature will not drop below -10°C.

Cor : **Current temp. correcting function**
This function (to be set within the range of -5 ~5°C) is used to correct temperature differences which may occur due to errors in sensors receiving external data, while the product itself is in normal operational condition.
e.g) Actual temperature is 10°C, but the temperature displayed is 12°C. Change the Cor 0.0 to -2°C to correct the difference and the temperature display will be corrected to 10°C.

dIF : **Deviation Temp. setting**
A constant interval is required between ON and OFF in ON/OFF control. (ON/OFF interval to be set)
Too-frequent ON and OFF operations may cause premature damage to relays and output contact points as well as hunting (oscillation, chattering) phenomenon. This function (to be set within the range of 0 ~20°C) is used to protect the product (contact points) from such damage.

e.g) dIF is set to 5°C and the temperature is set to 50°C. If the temperature detected by the sensor is below 45°C, the relay is ON, if the temperature detected by the sensor is above 50°C, the relay is turned OFF.

Set temperature = 50°C
dIF = 5°C
dLY = 0

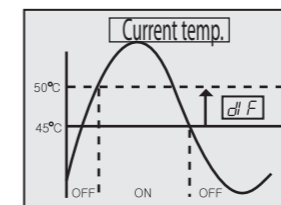

■ TIMER Program Function

ALn : Alarm Time Set
The function (to be set within the range of 0~999 seconds) is used to set the alarm time at the end of Timer.

Stn : Steam Time Set
This function (to be set within the range of 0~999 seconds) is used to utilize the steam preheated an external steamer.
⊕ If this lamp is turned on, the steamer is in the Preheat mode.
⊙ If this lamp is turned on, steam is in the Ready mode.

dLY : Delay time set
This function (to be set within the range of 0~20 seconds) is used to control too frequent ON/OFF operations of the equipment.

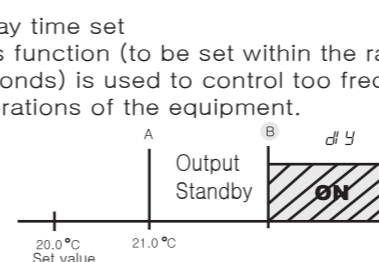

e.g) If the dLY value is set to 1, the delay time from the point A to the point B is delayed for 1 minute and the delay is turned back on at the point B.

8 Factory settings

J - N900		
Display	Range	Initial Value
TIMER	0 ~ 99 min	0
TOP	0 ~ 300°C	0°C
FLOOR	0 ~ 300°C	0°C
HI -	0 ~ 500°C	300°C
Lo-	-40 ~ 0°C	0°C
Cor	-5 ~ 5°C	0°C
dIF	1 ~ 20°C	1°C
ALn	0 ~ 999sec	60 sec
Stn	0 ~ 999sec	5 sec
dLY	0 ~ 20 sec	0 sec

9 Connection Diagram

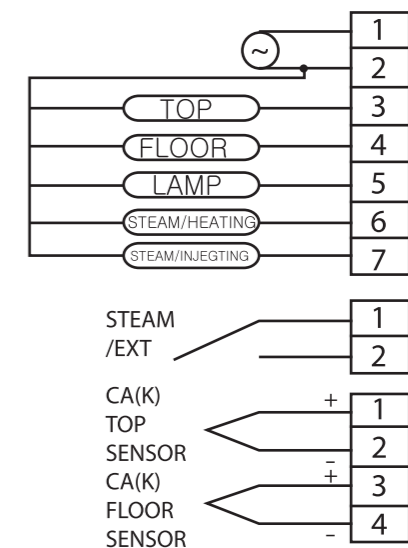

10 Quick Error Diagnosis

- **o-E** : This is displayed when sensors are not connected.
- **L-E** : This is displayed when the temperature drops below -50°C.
- **H-E** : This is displayed when the temperature rises above 300°C

* The above specification is subject to change for the further improvement without prior notice. Please read the entire instruction manual carefully before operating this equipment.

* Regarding the English-language manual, please download it at our homepage.

- Head office : B-107, Techno Plaza, 681-11 Jeonpo-1dong, Jingu, Busan Korea
- R&D Center : B-411, Techno Plaza, 681-11 Jeonpo-1dong, Jingu, Busan Korea
- Factory : B-408, 409, 410 Techno Plaza, 681-11 Jeonpo-1dong, Jingu, Busan Korea
- A/S Center : Tel 051-819-0425~7
- Return the product to the Head office for A/S
- E-mail : foxeng@foxeng.co.kr Homepage : www.foxeng.co.kr

This product should operate under the following environment.
Surrounding temperature : 0°C ~ 60°C
Surrounding humidity : Less than 80% Rh
Rated Power : 220VAC ±10% 50/60Hz

■ Main products and Developments
-Digital temperature/humidity controllers.
-Digital timers, current/voltage meters.
-Development of various other products.