

CC1101PATR无线模块规格书

专业生产无线模块

QQ : 284382376

TEL : 15323421599

433M 带PA远距离无线模块

Description

CC1101PATR4S is an FSK Transceiver module. The CC1101PATR4S is a true single-chip UHF transceiver, It base on 3 wire digital serial interface and an entire Phase-Locked Loop (PLL) for precise local oscillator generation .so the frequency could be setting. It can use in UART / NRZ / Manchester encoding / decoding. CC1101PATR4S had a high performance and low cost. It could easily to design your product.

It can be used on wireless security system or specific remote-control function and others wireless system

Features

- | Integrated bit synchronizer.
- | Integrated IF and data filters.
- | High sensitivity (type -115dBm at 2.4kbps)
- | Programmable output power -20dBm~30dBm
- | Operation temperature range : -40°C ~+85°C
- | Operation voltage: 5Volts.
- | Available frequency at : 408~464 MHz
- | Digital RSSI
- | Digital function for package format

Applications

- | Car security system
- | Remote keyless entry ò Garage door controller ò Home security
- | Wireless mouse
- | Automation system

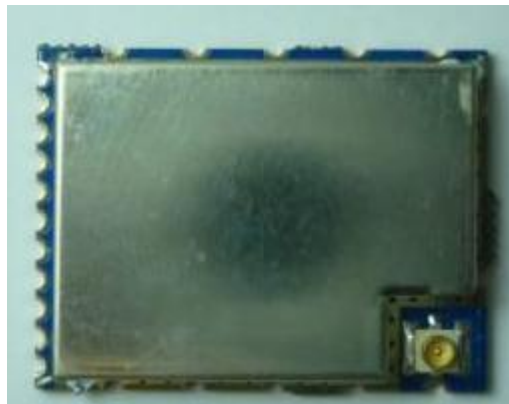

CC1101PATR无线模块规格书

专业生产无线模块

QQ : 284382376

TEL : 15323421599

433M 带PA远距离无线模块

Pin Dimension

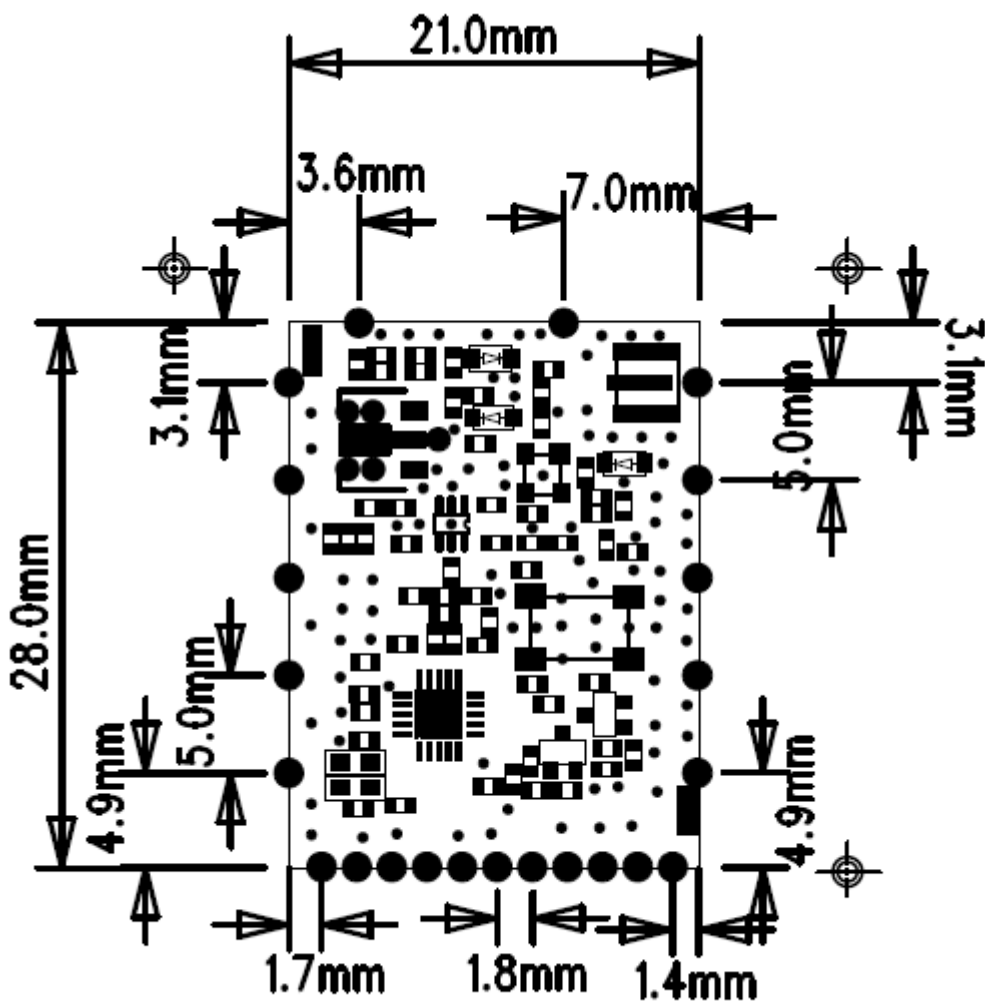

PIN#	Pin name	Pin type	Description
1	GND	Ground	GND
2	PA_VCC	PA power	3.3-9V PA power
3	+3V3	power	3.3V
4	SI	Digital input	Serial configuration interface, data input
5	SCLK	Digital input	Serial configuration interface, clock input

CC1101PATR无线模块规格书

专业生产无线模块

QQ : 284382376

TEL : 15323421599

6	SO	Digital Output	Serial configuration interface, clock input Optional general output pin when CSN is high
7	GDO2	Digital Output	Digital output pin for general use;
8	GDO0	Digital I/O	Digital output pin for general use;
9	CSN	Digital input	Serial configuration interface ,chip select
10	TX-EN	TX_EN	TX enable
11	RX-EN	RX-EN	RX enable

Electrical Specifications

Tc = 25°C, VDD = 5.0V

Parameter	Min	Typ	Max	Unit	Condition
Current consumption, TX	300	350	380	mA	Transmit mode, +30dBm output power 9V PA_VCC
Current consumption, TX	100	150	180	mA	Transmit mode, +20dBm output power 3.3V PA_VCC
Current consumption, RX	15	20	30		receiver
Current consumption,STB		TAB			Stand by

General Characteristics

Parameter	Min	Typ	Max	Unit	Condition/Note
Frequency range	408	433	464	MHz	
Data rate	1.2	500	kbps	Modulation formats supported: (Shaped) MSK (also known as differential offset QPSK) up to 500kbps 2-FSK up to 500kbps GFSK and OOK/ASK (up to 250kbps) Optional Manchester encoding (halves the data rate).

CC1101 RF Receive Section

Tc = 25°C, VDD = 3.0V

Parameter	Min	Typ	Max	Unit	Condition/Note
Differential input impedance		TBD		Ω	Follow CC1101EM reference design
Receiver sensitivity 315/433/868/915MHz	-110	-115		dBm	2-FSK, 1.2kbps, 5.2kHz deviation, 1% packet error rate, 62 bytes packet length, 58kHz digital channel filter bandwidth
	-100	-105		dBm	2-FSK, 38.4kbps, 20kHz deviation, 1% packet error rate, 62 bytes packet length, 100kHz digital channel filter bandwidth
	-89	-92		dBm	2-FSK, 250kbps, 127kHz deviation, 1% packet error rate, 62 bytes packet length, 540kHz digital channel filter bandwidth

CC1101PATR无线模块规格书

专业生产无线模块

QQ : 284382376

TEL : 15323421599

	89	-92		dBm	OOK, 250kbps OOK, 1% packet error rate, 62 bytes packet length, 540kHz digital channel filter bandwidth
Saturation		-15		dBm	
Digital channel filter bandwidth	58		650	kHz	User programmable. The bandwidth limits are proportional to crystal frequency (given values assume a 26.0MHz crystal).
Adjacent channel rejection, 868MHz		23		dB	2-FSK, 38.4kbps, 20kHz deviation, 1% packet error rate, 62 bytes packet length, 100kHz digital channel filter, 150kHz channel spacing Desired channel 3dB above the sensitivity limit
Alternate channel rejection, 868MHz		33		dB	2-FSK, 38.4kbps, 20kHz deviation, 1% packet error rate, 62 bytes packet length, 100kHz digital channel filter, 150kHz channel spacing Desired channel 3dB above the sensitivity limit.
Image channel rejection, 868MHz		29		dB	2-FSK, 38.4kbps, 20kHz deviation, 1% packet error rate, 62 bytes packet length, 100kHz digital channel filter, 150kHz channel spacing, IF frequency 305kHz Desired channel 3dB above the sensitivity limit.
Blocking at 1MHz offset, 868MHz		52		dB	Desired channel 3dB above the sensitivity limit. Compliant to ETSI EN 300 220 class 2 receiver requirement.
Blocking at 2MHz offset, 868MHz		54		dB	Desired channel 3dB above the sensitivity limit. Compliant to ETSI EN 300 220 class 2 receiver requirement.
Blocking at 5MHz offset, 868MHz		61		dB	Desired channel 3dB above the sensitivity limit. Compliant to ETSI EN 300 220 class 2 receiver requirement.
Blocking at 10MHz offset, 868MHz		64		dB	Desired channel 3dB above the sensitivity limit. Compliant to ETSI EN 300 220 class 2 receiver requirement.
Spurious emissions		-57 -47		dBm dBm	25MHz – 1GHz Above 1GHz

CC1101PATR无线模块规格书

专业生产无线模块

QQ : 284382376

TEL : 15323421599

433M 带PA远距离无线模块

CC1101 RF Transmit Section

Tc = 25°C, VDD = 3.0V, +10dBm if nothing else stated. Measured on Chipcon's CC1100EM reference design.

Parameter	Min	Typ	Max	Unit	Condition/Note
Differential load impedance		TBD		Ω	Follow CC1100EM reference design
Output power, highest setting		10		dBm	Output power is programmable, and full range is available in all frequency bands. Delivered to a 50 Ω single-ended load via Chipcon reference RF matching network.
Output power, lowest setting		-30		dBm	Output power is programmable, and full range is available in all frequency bands. Delivered to a 50 Ω single-ended load via Chipcon reference RF matching network.
Spurious emissions and harmonics, 433/868MHz			-36	dBm	25MHz – 1GHz
			-54	dBm	47-74, 87.5-118, 174-230, 470-862MHz
			-47	dBm	1800MHz-1900MHz (restricted band in Europe), when the operating frequency is below 900MHz (2 nd harmonic can not fall within this band when used in Europe)
			-30	dBm	Otherwise above 1GHz
Spurious emissions, 315/915MHz			-49.2	dBm EIRP	<200 μ V/m at 3m below 960MHz.
			-41.2	dBm EIRP	<500 μ V/m at 3m above 960MHz.
Harmonics 315MHz			-20	dBc	2 nd , 3 rd and 4 th harmonic when the output power is maximum 6mV/m at 3m. (-19.6dBm EIRP)
			-41.2	dBm	5 th harmonic
Harmonics 915MHz			-20	dBc	2 nd harmonic
			-41.2	dBm	3 rd , 4 th and 5 th harmonic

CC1101PATR无线模块规格书

专业生产无线模块

QQ : 284382376

TEL : 15323421599

433M 带PA远距离无线模块

Crystal Oscillator

A crystal in the frequency range 26MHz-27MHz must be connected between the XOSC_Q1 and XOSC_Q2 pins. The oscillator is designed for parallel mode operation of the crystal. In addition, loading capacitors (C81 and C101) for the crystal are required. The loading capacitor values depend on the total load capacitance, C_L , specified for the crystal. The total load capacitance seen between the crystal terminals should equal C_L for the crystal to oscillate at the specified frequency.

$$C_L = \frac{1}{\frac{1}{C_{81}} + \frac{1}{C_{101}}} + C_{parasitic}$$

The parasitic capacitance is constituted by pin input capacitance and PCB stray capacitance. Total parasitic capacitance is typically 2.5pF.

The crystal oscillator circuit is shown in Figure 16. Typical component values for different values of C_L are given in Table 26.

The crystal oscillator is amplitude regulated. This means that a high current is used to start up the oscillations. When the amplitude builds up, the current is reduced to what is necessary to maintain approximately 0.4Vpp signal swing. This ensures a fast start-up, and keeps the drive level to a minimum. The ESR of the crystal should be within the specification in order to ensure a reliable start-up (see section 7 on page 9).

The initial tolerance, temperature drift, aging and load pulling should be carefully specified in order to meet the required frequency accuracy in a certain application. By specifying the *total* expected frequency accuracy in SmartRF® Studio together with data rate and frequency deviation, the software calculates the total bandwidth and compares this to the chosen receiver channel filter bandwidth. The software reports any contradictions, and a more accurate crystal is recommended if required.

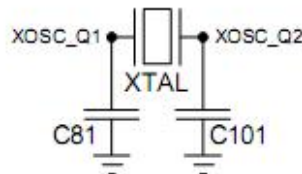

Figure 16: Crystal oscillator circuit

Component	$C_L = 10\text{pF}$	$C_L = 13\text{pF}$	$C_L = 16\text{pF}$
C81	15pF	22pF	27pF
C101	15pF	22pF	27pF

CC1101PATR无线模块规格书

专业生产无线模块

QQ : 284382376

TEL : 15323421599

433M 带PA远距离无线模块

CC1101 Simplified Block Diagram

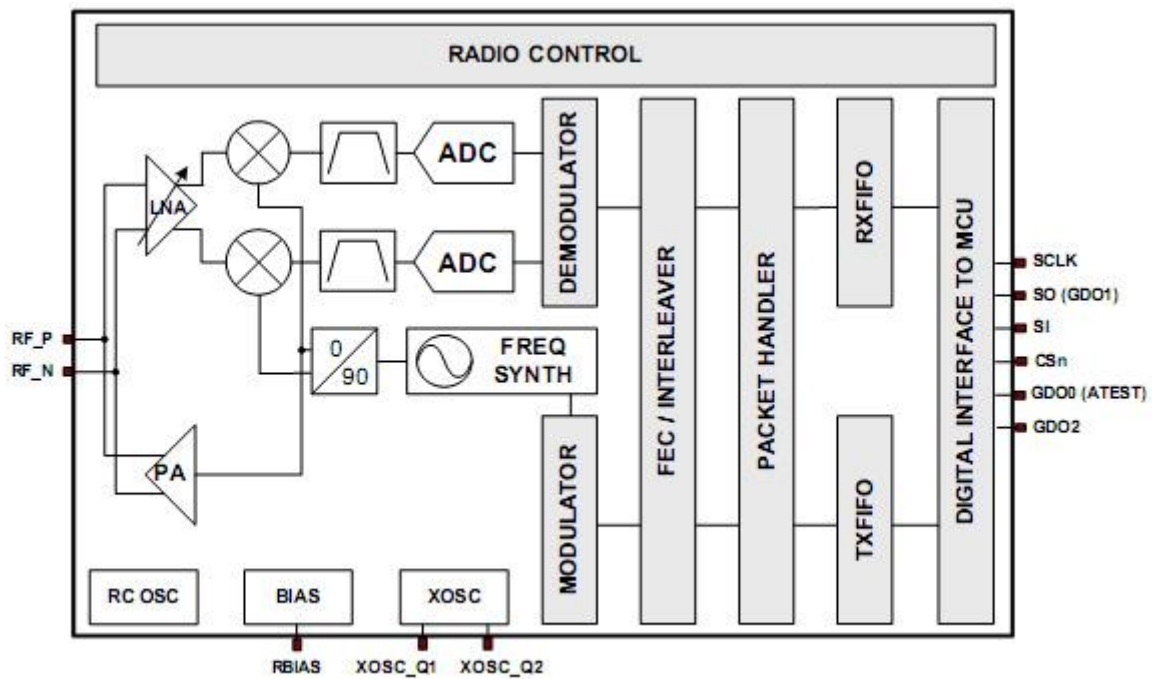

Schemactic N/A

CC1101` Selectivity

CC1101PATR无线模块规格书

专业生产无线模块

QQ : 284382376

TEL : 15323421599

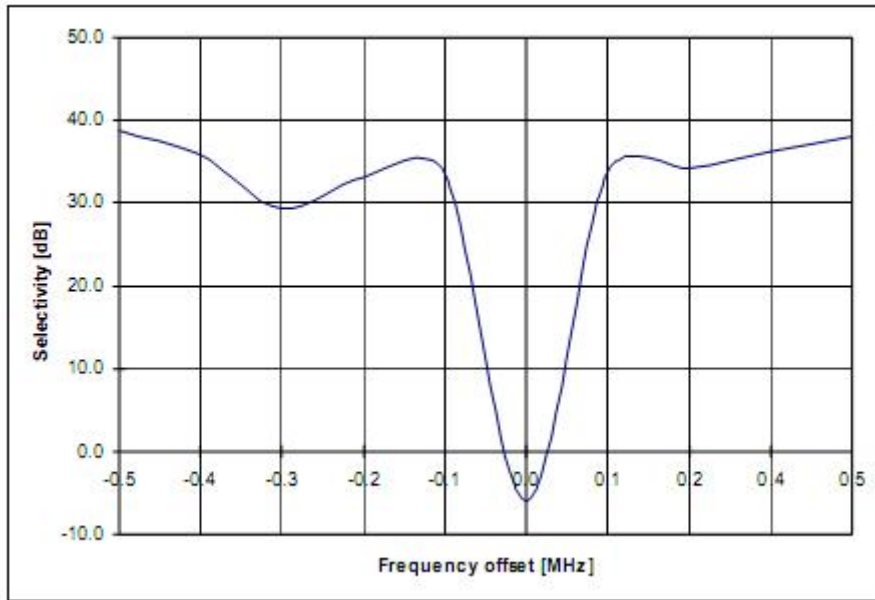

Selectivity at 1.2K Baud Data Rate

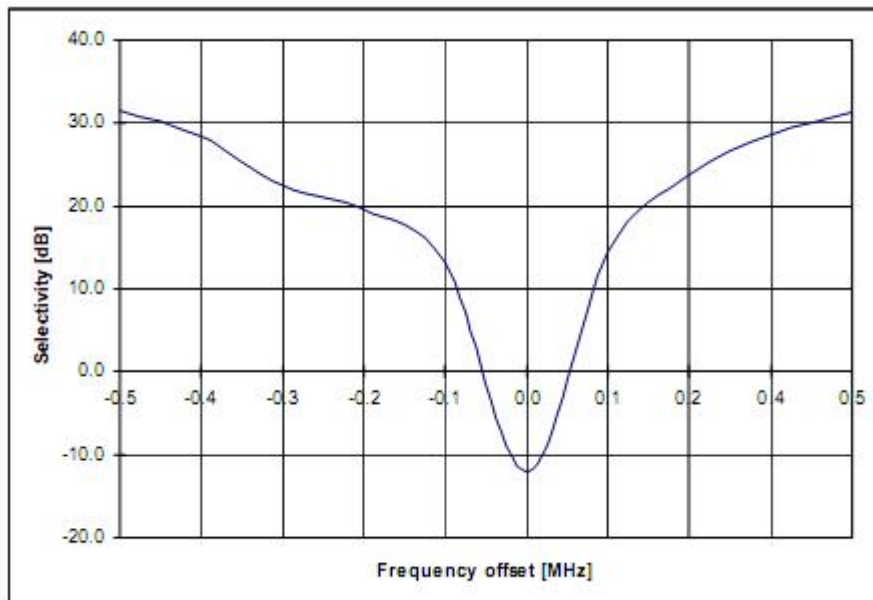

Selectivity at 38.4K Baud Data Rate

CC1101PATR无线模块规格书

专业生产无线模块

QQ : 284382376

TEL : 15323421599

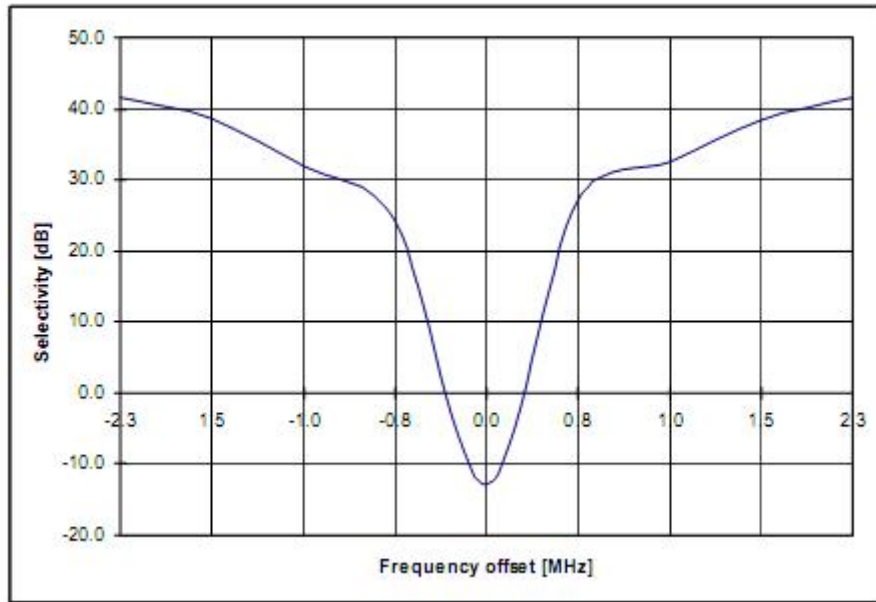

Selectivity at 250K Baud Data Rate

Mark:

- About Detail Specifications , Pls see CC1101 Data sheet .

<http://focus.ti.com/lit/ds/symlink/CC1101.pdf> www.ti.com

2SK3078

ELECTRICAL CHARACTERISTICS (Ta = 25°C)

CHARACTERISTIC	SYMBOL	TEST CONDITION	MIN	TYP.	MAX	UNIT
Output Power	P_O	$V_{DS} = 4.8\text{ V}$ $I_{idle} = 108\text{ mA}$ ($V_{GS} = \text{adjust}$) $f = 915\text{ MHz}$, $P_i = 14.5\text{ dBmW}$	27.0	—	—	dBmW
Drain Efficiency	η_D		—	46.0	—	%
Power Gain	G_P		12.5	—	—	dB
Threshold Voltage	V_{Th}	$V_{DS} = 4.8\text{ V}$, $I_D = 0.5\text{ mA}$	0.20	—	1.20	V
Drain Cut-off Current	I_{DSS}	$V_{DS} = 10\text{ V}$, $V_{GS} = 0\text{ V}$	—	—	10	μA
Gate-Source Leakage Current	I_{GSS}	$V_{GS} = 5\text{ V}$, $V_{DS} = 0\text{ V}$	—	—	5	μA

2SK3078 Characteristic

CC1101PATR无线模块规格书

专业生产无线模块

QQ : 284382376

TEL : 15323421599

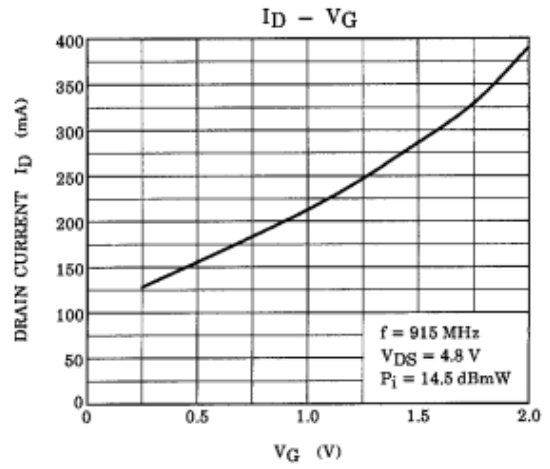
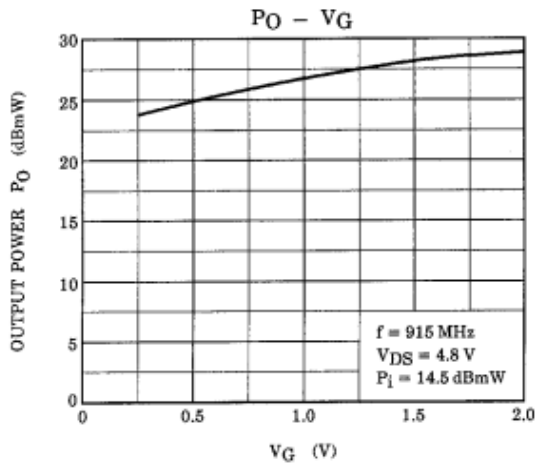
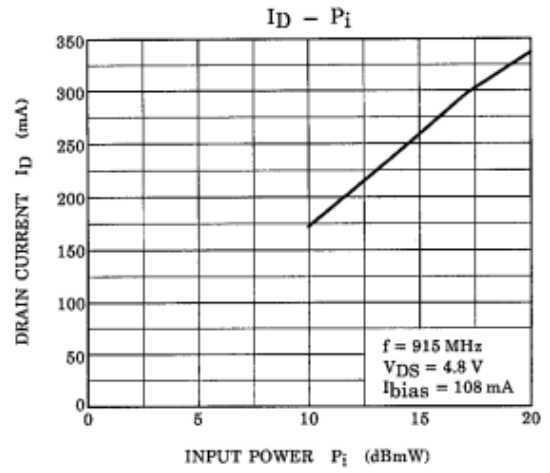
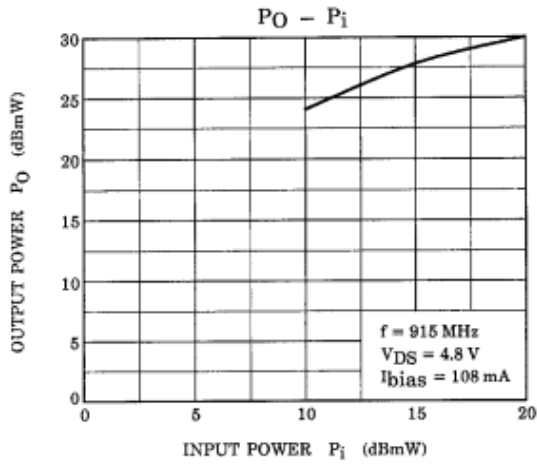

CC1101PATR无线模块规格书

专业生产无线模块

QQ : 284382376

TEL : 15323421599

NPN Silicon RF Transistor

Preliminary data

- For highest gain low noise amplifier at 1.8 GHz and 2 mA / 2 V

Outstanding $G_a = 20$ dB

Noise Figure $F = 0.95$ dB

- For oscillators up to 15 GHz
- Transition frequency $f_T = 45$ GHz
- Gold metalization for high reliability

• SIEGET® 45 - Line

Siemens Grounded Emitter Transistor

45 GHz f_T - Line

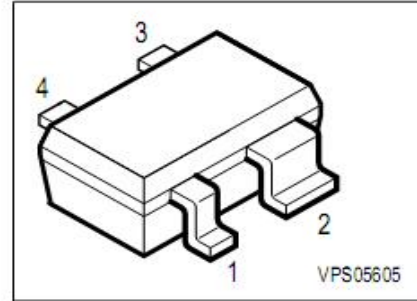

Power gain G_{ma} , G_{ms} , $|S_{21}|^2 = f(f)$
 $V_{CE} = 2V$, $I_C = 20$ mA

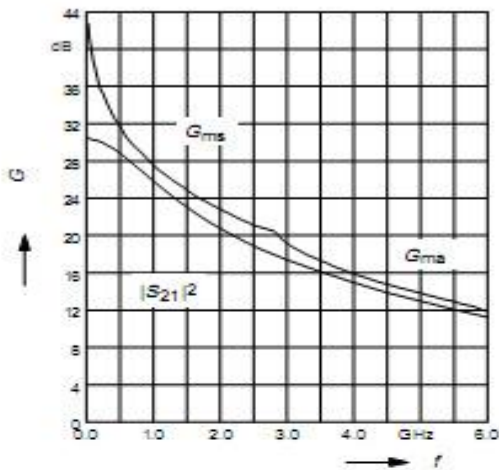

Power gain G_{ma} , $G_{ms} = f(I_C)$
 $V_{CE} = 2V$
 $f =$ parameter in GHz

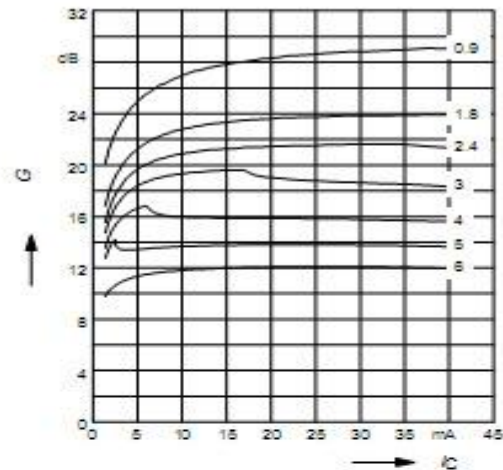

Power gain G_{ma} , $G_{ms} = f(V_{CE})$
 $I_C = 20$ mA
 $f =$ parameter in GHz

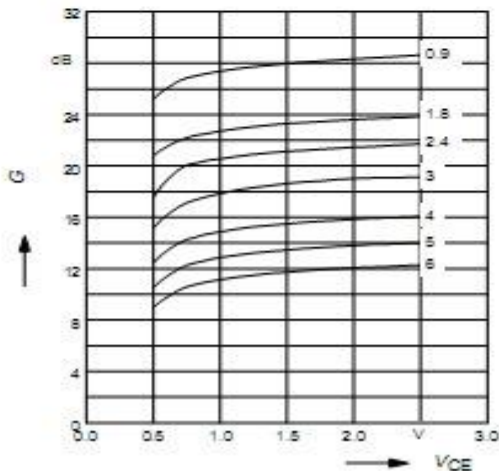

Collector-base capacitance $C_{cb} = f(V_{CB})$
 $V_{BE} = 0$, $f = 1$ MHz

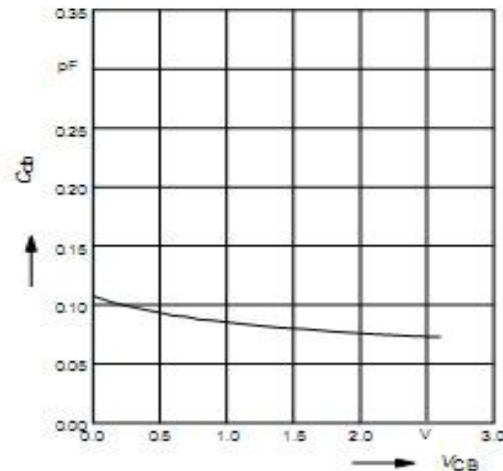

CC1101PATR无线模块规格书

专业生产无线模块

QQ : 284382376

TEL : 15323421599

Noise figure $F = f(I_C)$

$V_{CE} = 2\text{ V}$, $Z_S = Z_{Sopt}$

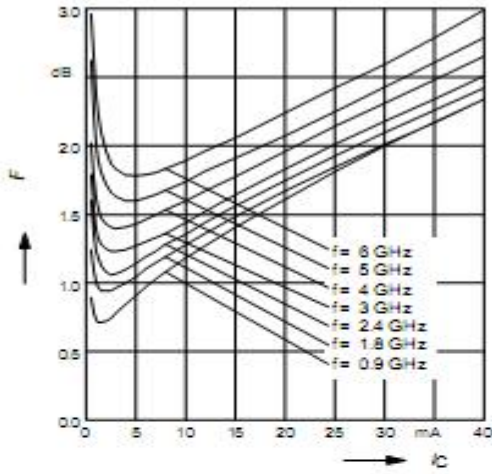

Noise figure $F = f(I_C)$

$V_{CE} = 2\text{ V}$, $f = 1.8\text{ GHz}$

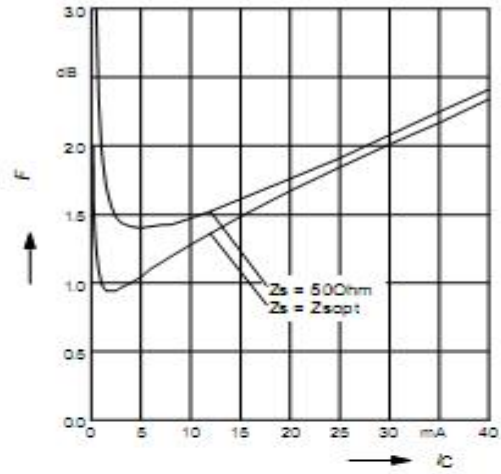

Noise figure $F = f(f)$

$V_{CE} = 2\text{ V}$, $Z_S = Z_{Sopt}$

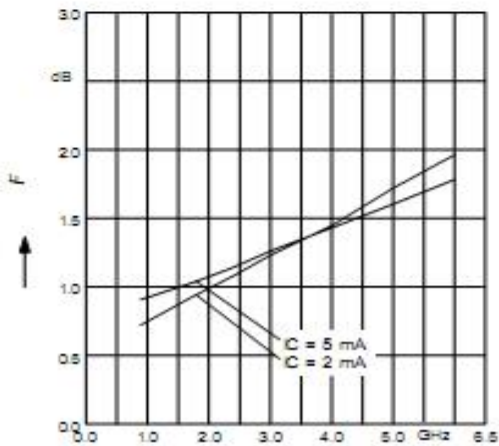

Source impedance for min.

Noise Figure vs. Frequency

$V_{CE} = 2\text{ V}$, $I_C = 2\text{ mA} / 5\text{ mA}$

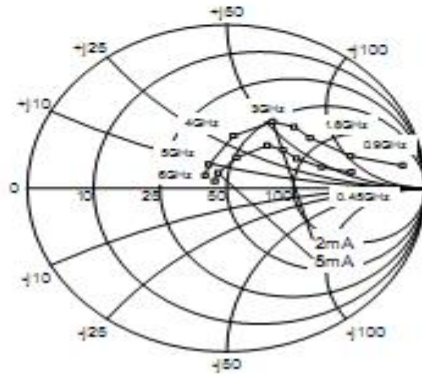

CC1101PATR无线模块规格书

专业生产无线模块

QQ : 284382376

TEL : 15323421599

AS179 RF Switch

AS179-92, AS179-92LF: PHEMT GaAs IC SPDT Switch DC-3 GHz

Applications

- General purpose medium power switches in telecommunication applications
- T/R switches in 802.11b, g WLAN Bluetooth™ systems

Features

- $P_{1\text{ dB}}$ +30 dBm typical @ +3 V
- IP3 43 dBm typical @ +3 V
- Low insertion loss (0.3 dB @ 0.9 GHz)
- Low DC power consumption
- Ultra miniature SC-70 6 lead package
- PHEMT process
- Available lead (Pb)-free MSL-1 @ 250 °C per JEDEC J-STD-020

Description

The AS179-92 is an IC FET SPDT switch in a low cost miniature SC-70 6 lead plastic package. The AS179-92 features low insertion loss and positive voltage operation with very low DC power consumption. This general purpose switch can be used in a variety of telecommunications applications.

SC-70 6 Lead

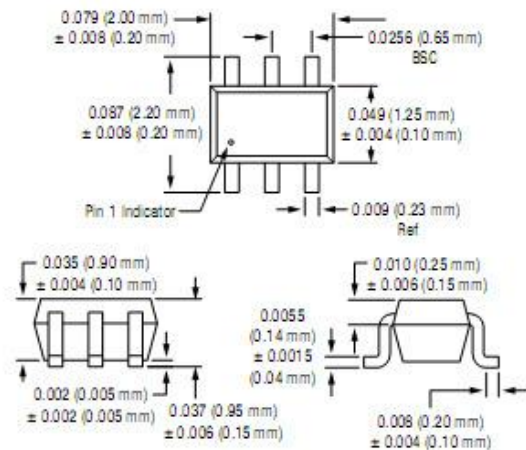

Truth Table

V_1	V_2	J_1-J_2	J_1-J_3
V_{HIGH}	0	Isolation	insertion loss
0	V_{HIGH}	insertion loss	Isolation

$V_{\text{HIGH}} = +3\text{ to }+5\text{ V}$.

Pin Out

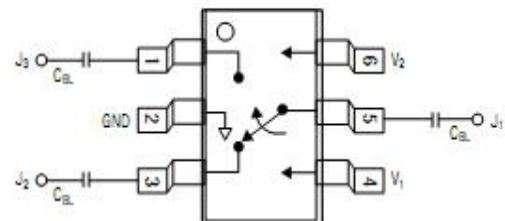

DC blocking capacitors (C_{BL}) must be supplied externally for positive voltage operation. $C_{\text{BL}} = 100\text{ pF}$ for operation > 500 MHz.

CC1101PATR无线模块规格书

专业生产无线模块

QQ : 284382376

TEL : 15323421599

Typical Performance Data (0, +3 V)

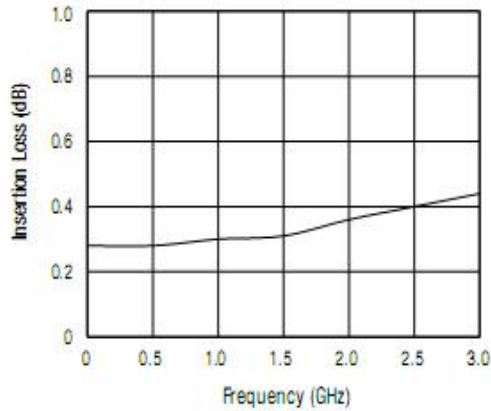

Insertion Loss vs. Frequency

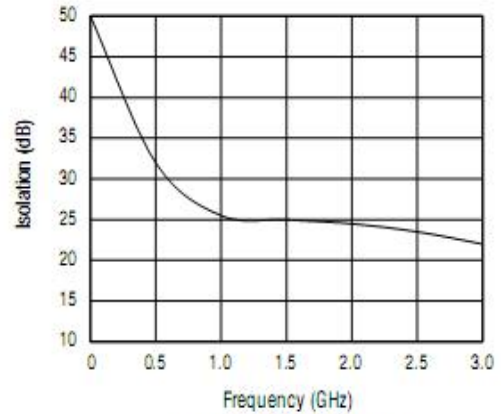

Isolation vs. Frequency

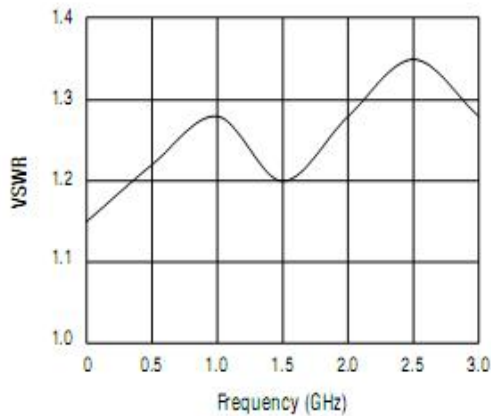

VSWR vs. Frequency

Absolute Maximum Ratings

Characteristic	Value
RF input power	6 W > 500 MHz 0/+7 V control
Control voltage	-0.2 V, +8 V
Operating temperature	-40 °C to +85 °C
Storage temperature	-65 °C to +150 °C
θ_{JC}	25 °C/W

Performance is guaranteed only under the conditions listed in the specifications table and is not guaranteed under the full range(s) described by the Absolute Maximum specifications. Exceeding any of the absolute maximum/minimum specifications may result in permanent damage to the device and will void the warranty.

CAUTION: Although this device is designed to be as robust as possible, Electrostatic Discharge (ESD) can damage this device. This device must be protected at all times from ESD. Static charges may easily produce potentials of several kilovolts on the human body or equipment, which can discharge without detection. Industry-standard ESD precautions must be employed.