

HA17555 Series

Precision Timer

REJ03D0681-0100
 (Previous: ADE-204-064)
 Rev.1.00
 Jun 15, 2005

Description

HA17555 Series are ICs designed for accurate time delays or oscillations. It provides both of trigger terminal and reset terminal in order to enable a wide scope of application including Mono Multi Vibrator and Astable Multi Vibrator, and the number of external components is fewer. Further, it's compatible with NE555 of singnetics.

Features

- Mono multi vibrator can be constructed with one resistor and one capacitor.
- Astable multi vibrator can be constructed with two resistors and one capacitor.
- Delay time can be established widely from several μ seconds to several hours.
- Pulse Duty can be controlled.
- The maximum value of both sink current and source current is 200mA.
- Direct connection of output to TTL is possible.
- Temperature/delay time ratio is 50 ppm/ $^{\circ}$ C (typ).
- Output is normally in the on and off states.

Ordering Information

Application	Type No.	Package Code (Previous Code)
Industrial use	HA17555PS	PRDP0008AF-A (DP-8B)
	HA17555FP	PRSP0008DE-B (FP-8DGV)
Commercial use	HA17555	PRDP0008AF-A (DP-8B)
	HA17555F	PRSP0008DE-B (FP-8DGV)

Applications

- Delay Time Generator (Mono Multi Vibrator)
- Pulse Generator (Astable Multi Vibrator)
- Pulse Width Modulator
- Pulse Location Modulator
- Miss Pulse Detector

Pin Arrangement

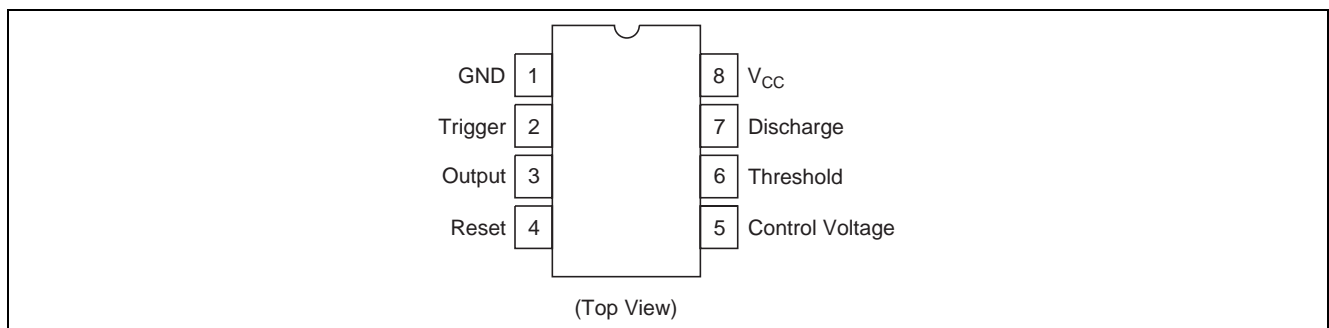

Pin Description

Pin No.	Function
1	Ground pin
2	Trigger pin
3	Output pin
4	Reset pin
5	Control voltage pin
6	Threshold pin
7	Discharge pin
8	V _{CC} pin

Circuit Schematic

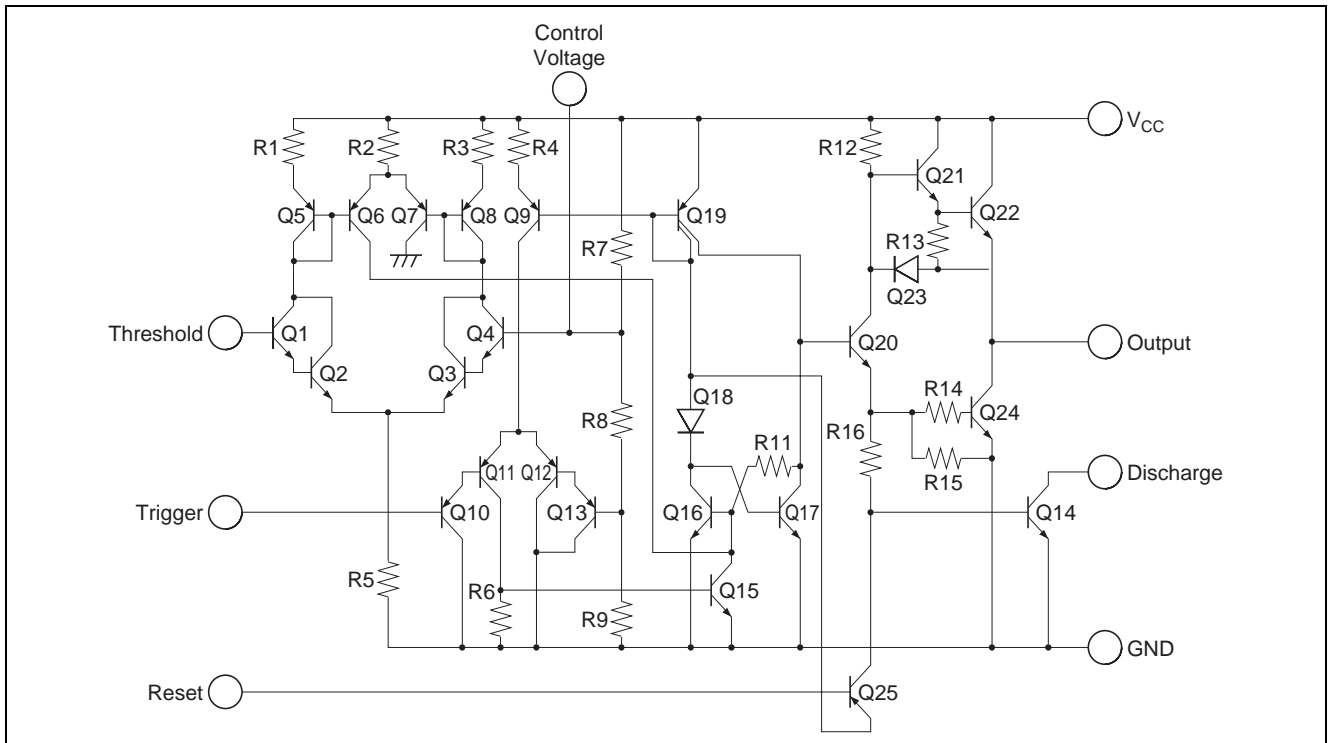

Block Diagram

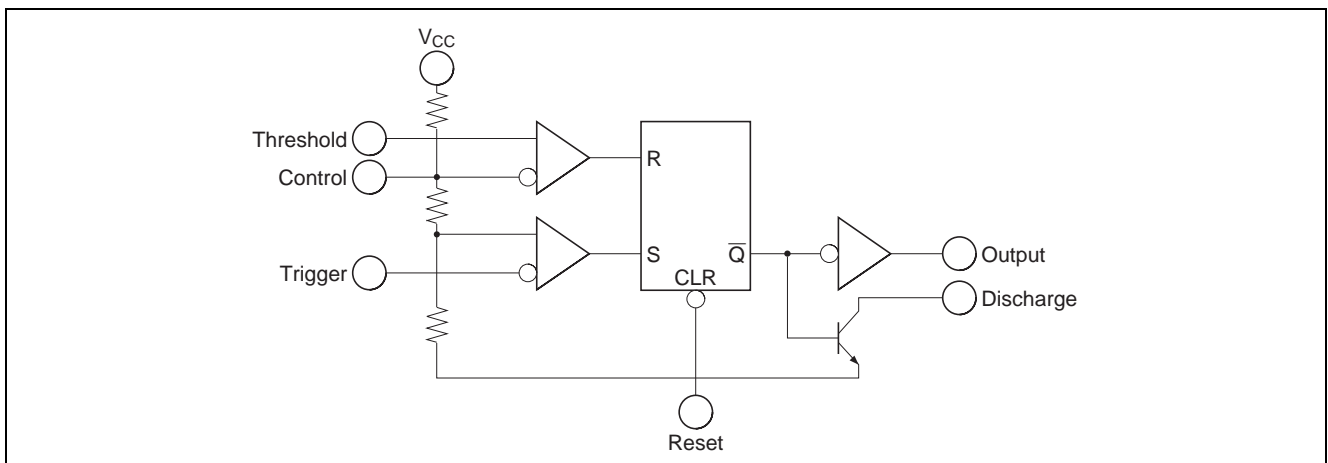

Absolute Maximum Ratings

(Ta = 25°C)

Item	Symbol	HA17555PS/FP	HA17555F	Unit
Supply voltage	V _{CC}	18	18	V
Discharge current	I _T	200	200	mA
Output source current	I _{source}	200	200	mA
Output sink current	I _{sink}	200	200	mA
Power dissipation*1	P _T	600/385	600/385	mW
Operating temperature	T _{opr}	-20 to +75	-20 to +70	°C
Storage temperature	T _{stg}	-55 to +125	-55 to +125	°C

Note: 1. For the HA17555/PS,

This value applies up to Ta = 50°C; at temperatures above this, 8.3mW/°C derating should be applied.

For the HA17555F/FP,

This value applies up to Ta = 25°C; at temperatures above this, 3.85mW/°C derating should be applied.

See notes on SOP Package Usage in Reliability section.

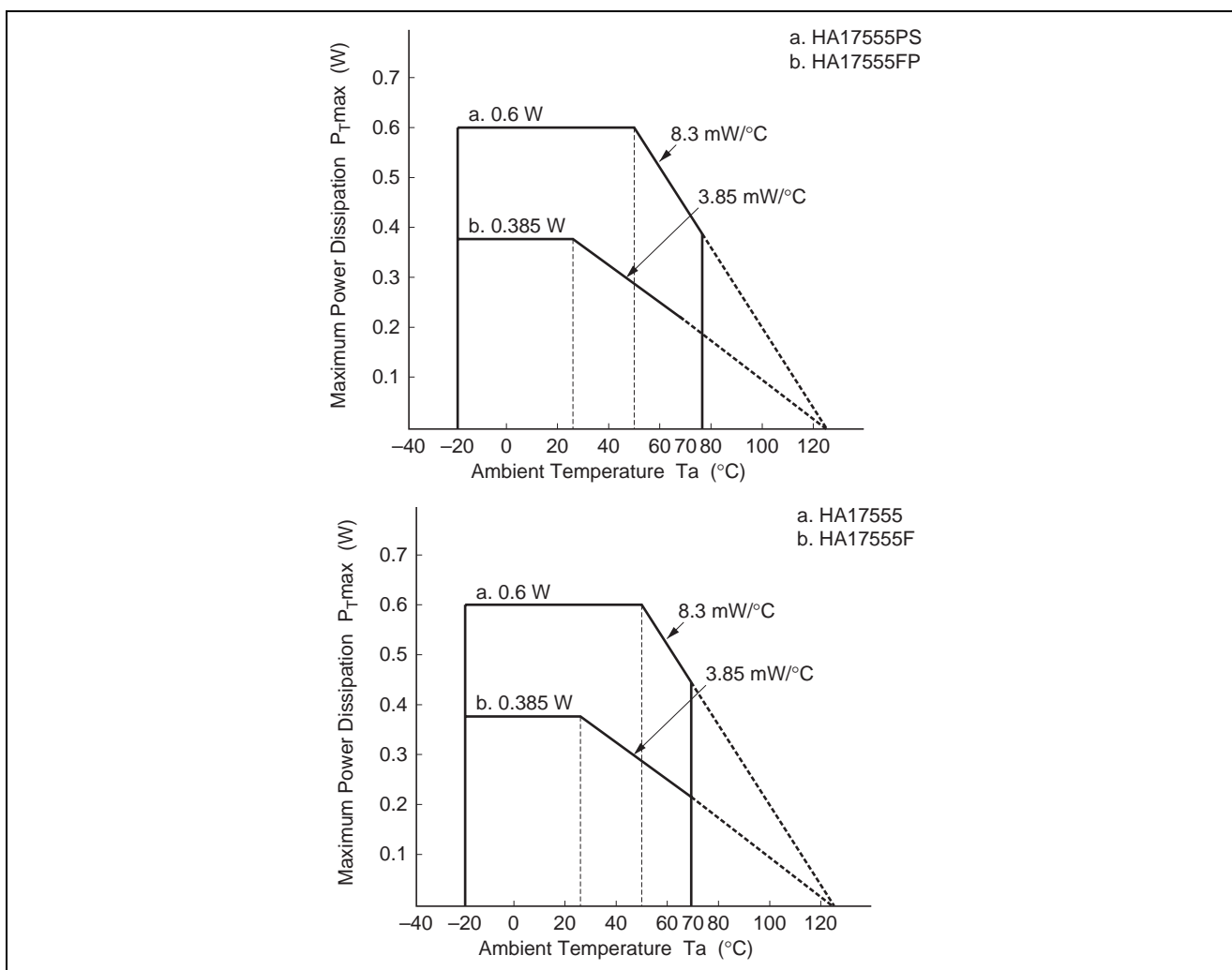

Electrical Characteristics

(V_{CC} = 5 to 15 V, T_a = 25°C)

Item	Symbol	Min	Typ	Max	Unit	Test conditions
Supply voltage* ¹	V _{CC}	4.5	—	16.0	V	
Supply current	I _{CC}	—	3.0	6.0	mA	V _{CC} = 5 V, R _L = ∞
	I _{CC}	—	10	15	mA	V _{CC} = 15 V, R _L = ∞
Timing error* ² (Inherent error)	Et	—	1.0	—	%	
Timing error* ² (T _a dependency)	Et	—	50	—	ppm/°C	T _a = -20 to +75°C
Timing error* ² (Voltage dependency)	Et	—	0.01	—	%/V	V _{CC} = 5 to 15 V
Threshold voltage	V _{th}	—	2/3	—	V × V _{CC}	
Trigger voltage	V _T	—	5.0	—	V	V _{CC} = 15 V
	V _T	—	1.67	—	V	V _{CC} = 5 V
Trigger current	I _T	—	0.5	—	μA	
Reset voltage	V _R	0.2	0.5	1.0	V	
Reset current	I _R	—	0.1	—	mA	
Threshold current	I _{th} * ³	—	0.1	0.25	μA	
Control voltage	V _{CL}	9	10	11	V	V _{CC} = 15 V
	V _{CL}	2.6	3.33	4.0	V	V _{CC} = 5 V
Output voltage	V _{OL}	—	0.1	0.25	V	V _{CC} = 15 V, I _{sink} = 10 mA
		—	0.4	0.75	V	V _{CC} = 15 V, I _{sink} = 50 mA
		—	2.0	2.5	V	V _{CC} = 15 V, I _{sink} = 100 mA
		—	2.5	—	V	V _{CC} = 15 V, I _{sink} = 200 mA
		—	0.25	0.35	V	V _{CC} = 5 V, I _{sink} = 5 mA
Output voltage	V _{OH}	—	12.5	—	V	V _{CC} = 15 V, I _{source} = 200 mA
		12.75	13.3	—	V	V _{CC} = 15 V, I _{source} = 100 mA
		2.75	3.3	—	V	V _{CC} = 5 V, I _{source} = 100 mA
Output rise time	t _r	—	100	—	ns	No loading
Output fall time	t _f	—	100	—	ns	No loading
Oscillation pulse width* ⁴	tw	10.0	—	—	ns	

Notes: 1. When output is low (When it is high, I_{CC} is lower by 1 mA typically.)2. R_A, R_B = 1 k to 100 kΩ, C = 0.1 μF, V_{CC} = 5 V or 15 V.3. (R_A + R_B) at V_{CC} = 15 V is determined by the value of I_{th}. It is 20 MΩ Max.

4. Output pulse width at mono multi circuit. Output high level pulse width at astable circuit.

Characteristic Curves

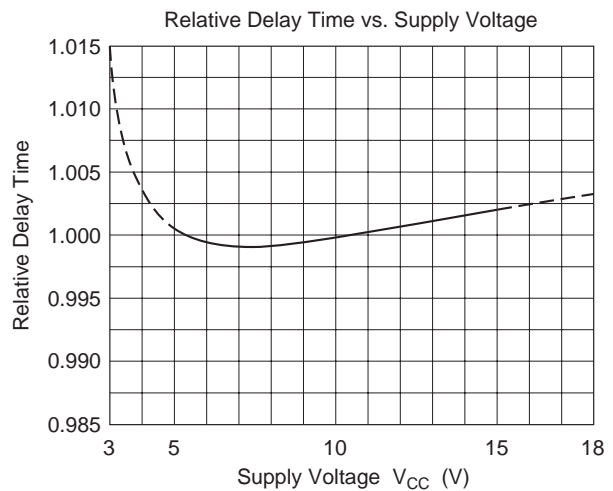
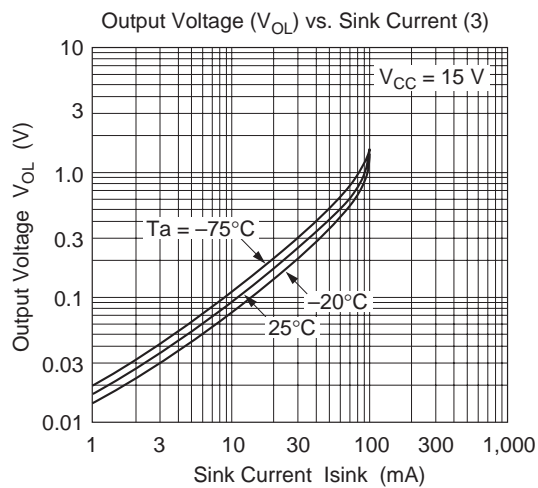
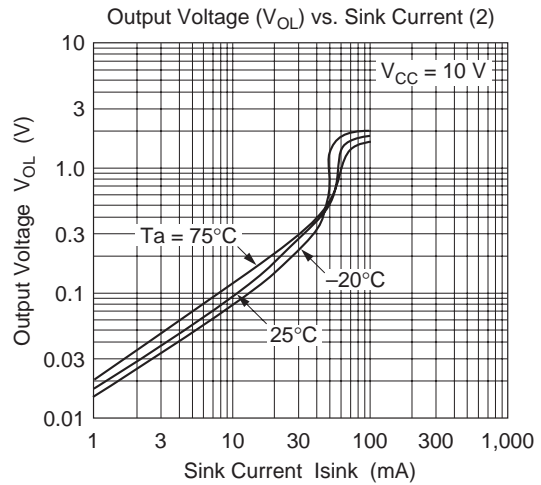
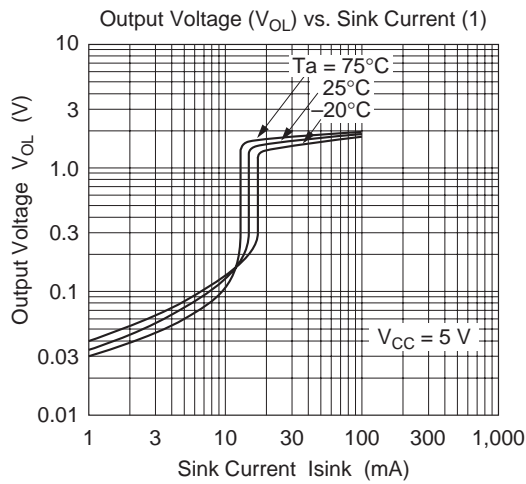
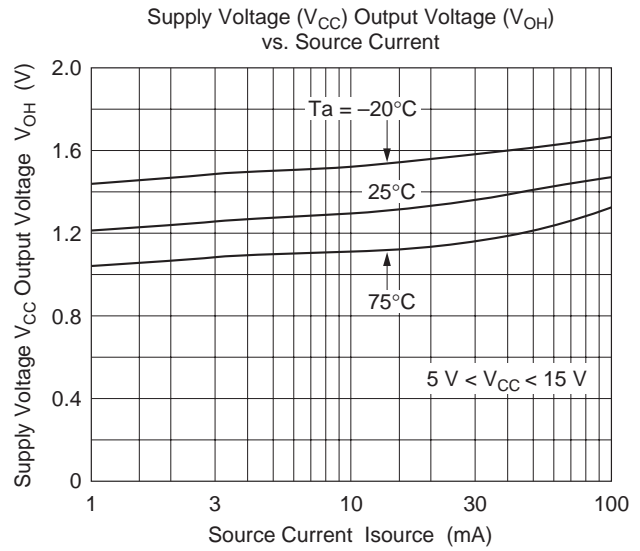
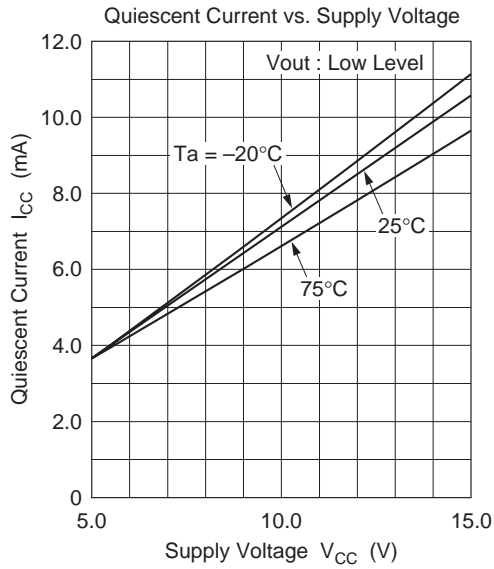

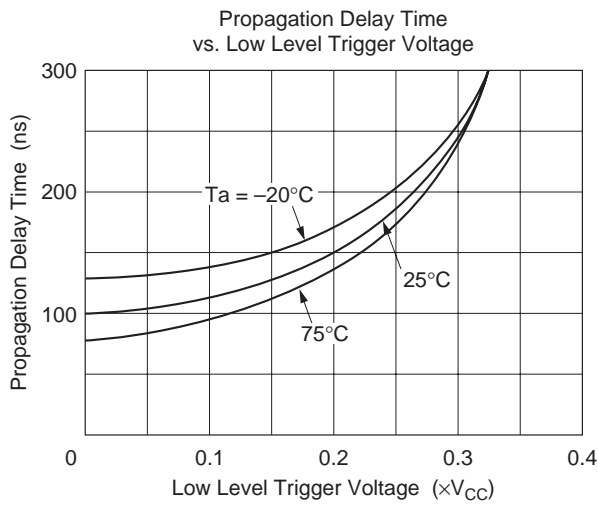
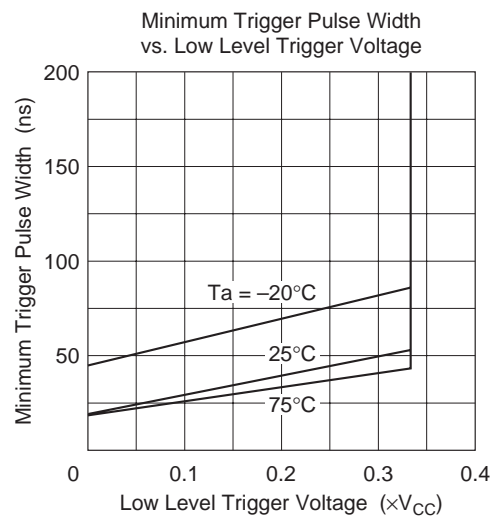
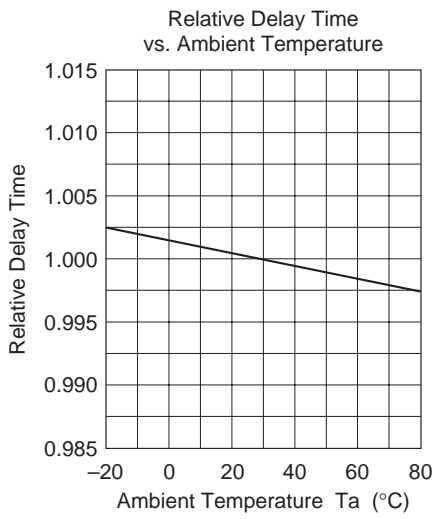

Package Dimensions

