

JPG 转 PDF 转换器 – 未注册版

如果您需要去掉这行字，请注册 JPG 转 PDF 转换器

连接器配件图

Connector Component

HA200E(200AP)
主要技术特性: Main Specifications
间距 Pitch: 2.0mm
线数 Lines: 2-6
适合电线范围 Applicable wire range: AWG32#~28#
环境温度 Environment temperature: -25℃~+85℃
额定电压 Rate voltage: 100V AC, DC
额定电流 Rate current: 2.0A AC, DC
接触电阻 Contact resistance: $\leq 20m\Omega$
绝缘电阻 Insulation resistance: $\geq 1000m\Omega$
耐压 Voltage resisting: AC800V.1min

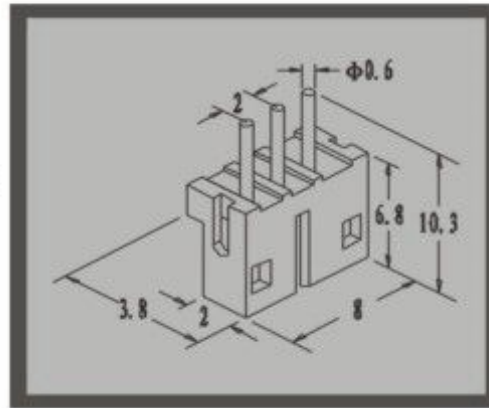

HAA200E-n

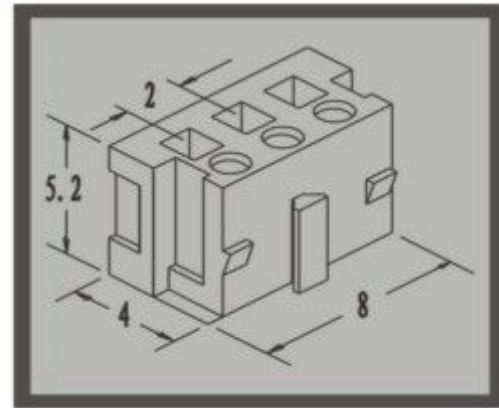

HAY200E-n

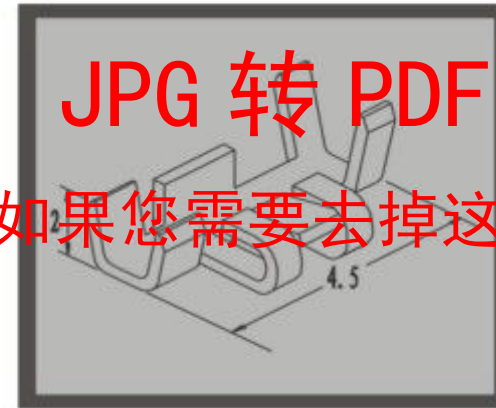

HAS200E-PT

HA200F(2.0杜邦)
主要技术特性: Main Specifications
间距 Pitch: 2.0mm
线数 Lines: 2-30
适合电线范围 Applicable wire range: AWG30#~24#
环境温度 Environment temperature: -25℃~+85℃
额定电压 Rate voltage: 250V AC, DC
额定电流 Rate current: 2.0A AC, DC
接触电阻 Contact resistance: $\leq 20m\Omega$
绝缘电阻 Insulation resistance: $\geq 1000m\Omega$
耐压 Voltage resisting: AC800V.1min

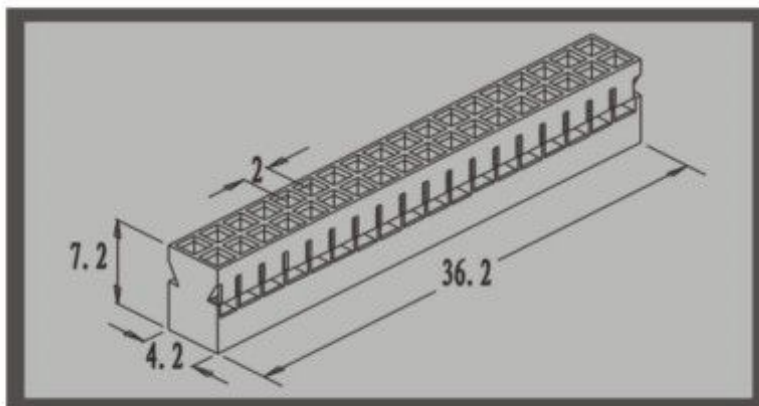

HAY200F-n

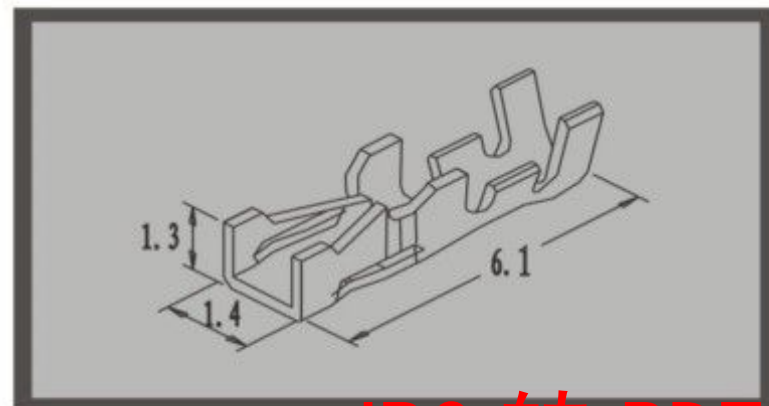

HAS200F-PT

HA200G(PHD)
主要技术特性: Main Specifications
间距 Pitch: 2.0mm
线数 Lines: 6-40
适合电线范围 Applicable wire range: AWG30#~22#
环境温度 Environment temperature: -25℃~+85℃
额定电压 Rate voltage: 250V AC, DC
额定电流 Rate current: 2.0A AC, DC
接触电阻 Contact resistance: $\leq 20m\Omega$
绝缘电阻 Insulation resistance: $\geq 1000m\Omega$
耐压 Voltage resisting: AC800V.1min

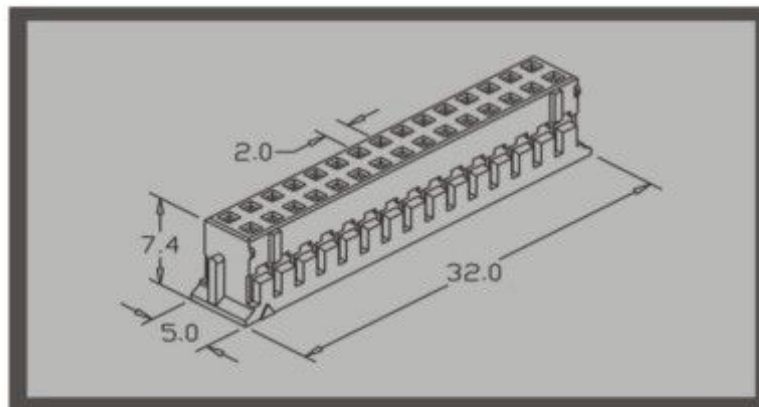

HAY200G-PHD

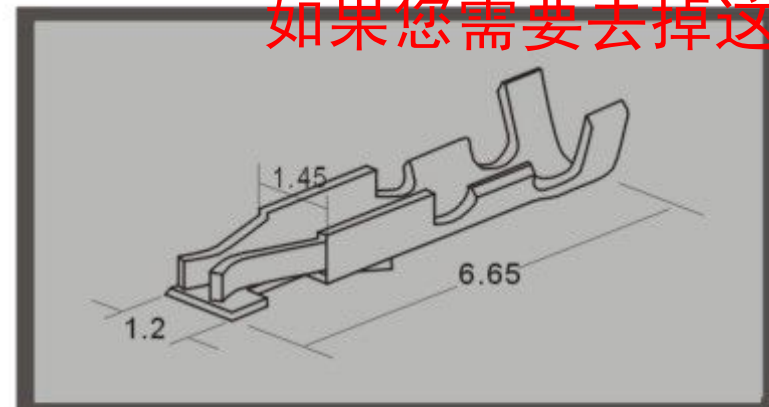

HAS200F-PT/PHD-PT

HA250A(XH)
主要技术特性: Main Specifications
间距 Pitch: 2.0mm
线数 Lines: 2-20
适合电线范围 Applicable wire range: AWG30#~2#
环境温度 Environment temperature: -25℃~+85℃
额定电压 Rate voltage: 250V AC, DC
额定电流 Rate current: 3.0A AC, DC
接触电阻 Contact resistance: $\leq 10m\Omega$
绝缘电阻 Insulation resistance: $\geq 1000m\Omega$
耐压 Voltage resisting: AC1000V.1min

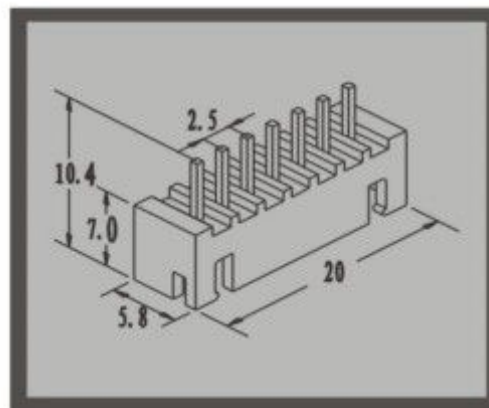

HAA250A-n/XH-nA

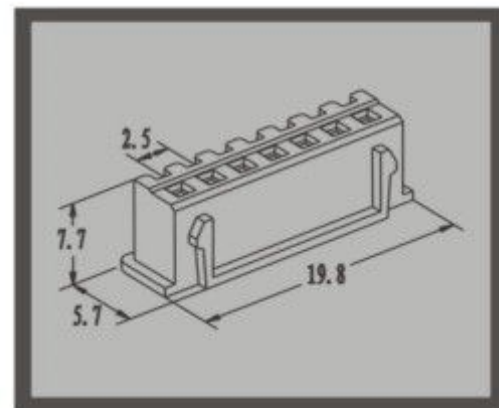

HAY250A-n/XH-nY

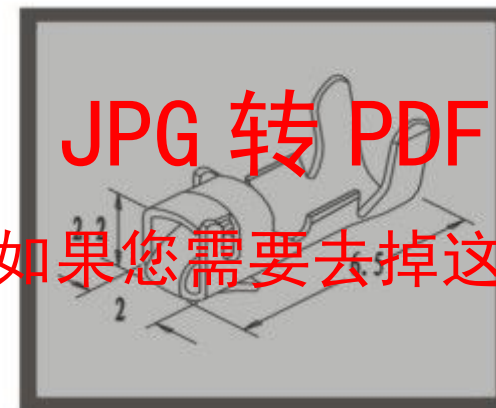

HAS250A-PT/XH-PT

HA250B(EH)
主要技术特性: Main Specifications
间距 Pitch: 2.5mm
线数 Lines: 2-20
适合电线范围 Applicable wire range: AWG30#~22#
环境温度 Environment temperature: -25℃~+85℃
额定电压 Rate voltage: 250V AC, DC
额定电流 Rate current: 2.0A AC, DC
接触电阻 Contact resistance: $\leq 10m\Omega$
绝缘电阻 Insulation resistance: $\geq 1000m\Omega$
耐压 Voltage resisting: AC800V.1min

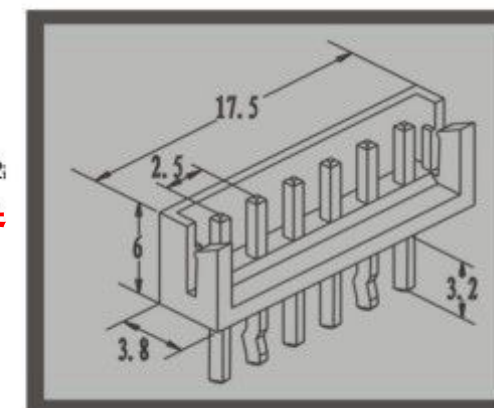

HAA250B-n/EH-nA

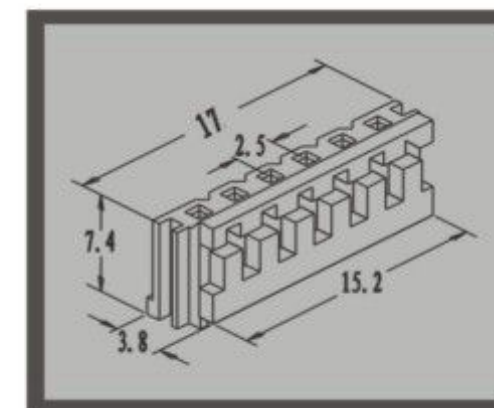

HAY250B-n/EH-nY

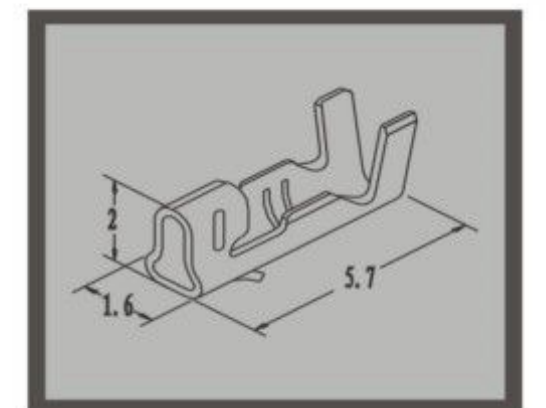

HAS250B-PT/EH-PT

HA250C(SCN)
主要技术特性: Main Specifications
间距 Pitch: 2.5mm
线数 Lines: 2-30
适合电线范围 Applicable wire range: AWG28#~22#
环境温度 Environment temperature: -25℃~+85℃
额定电压 Rate voltage: 250V AC, DC
额定电流 Rate current: 2.0A AC, DC
接触电阻 Contact resistance: $\leq 10m\Omega$
绝缘电阻 Insulation resistance: $\geq 1000m\Omega$
耐压 Voltage resisting: AC800V.1min

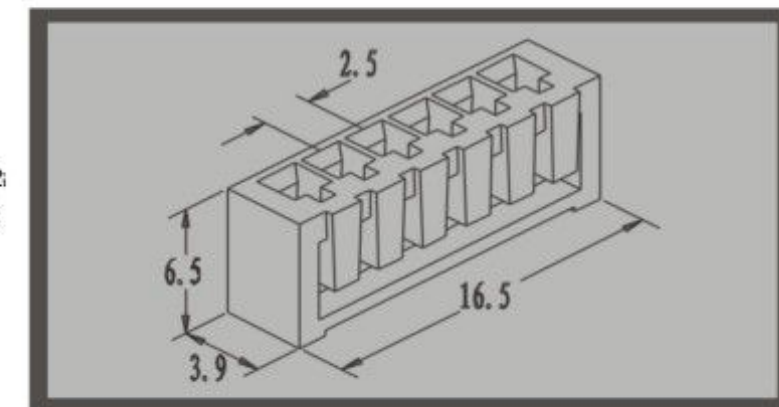

HAY250C-n/SCN-nY

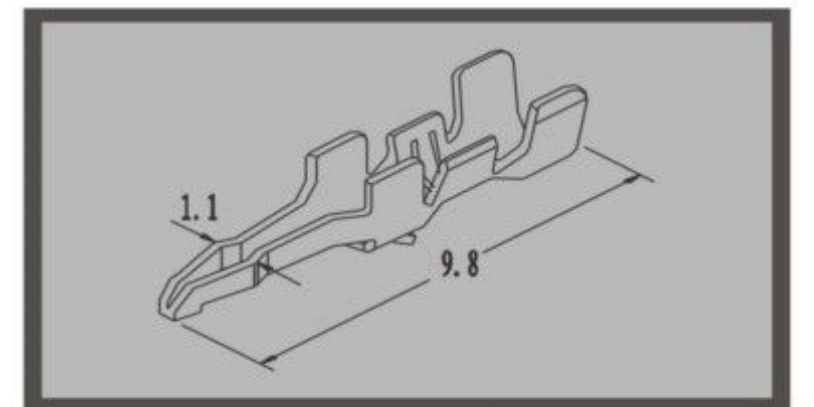

HAS250C-PT/SCN-PT

HA250D(NC25)
主要技术特性: Main Specifications
间距 Pitch: 2.5mm
线数 Lines: 2-30
适合电线范围 Applicable wire range: AWG30#~22#
环境温度 Environment temperature: -25℃~+85℃
额定电压 Rate voltage: 250V AC, DC
额定电流 Rate current: 2.0A AC, DC
接触电阻 Contact resistance: $\leq 10m\Omega$
绝缘电阻 Insulation resistance: $\geq 1000m\Omega$
耐压 Voltage resisting: AC800V.1min

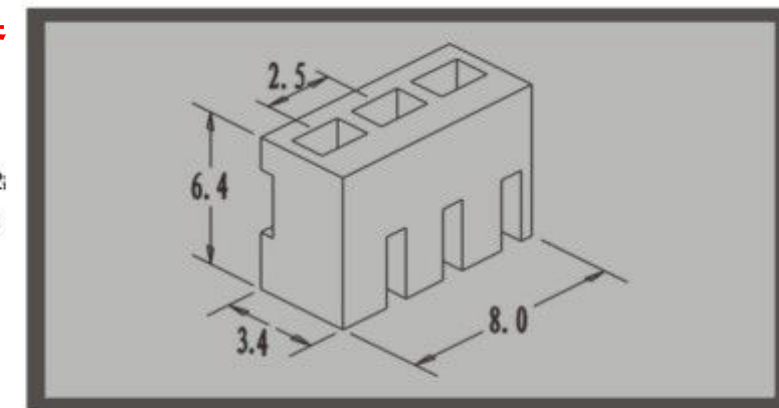

HAY250D-n/NC25-nY

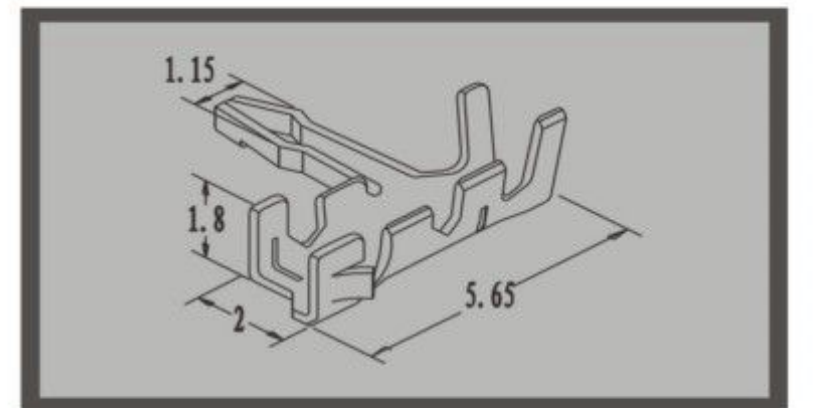

HAS250D-PT/JC25-PT

HA250E(5264)
主要技术特性: Main Specifications
间距 Pitch: 2.5mm
线数 Lines: 2-15
适合电线范围 Applicable wire range: AWG28#~2#
环境温度 Environment temperature: -25℃~+85℃
额定电压 Rate voltage: 250V AC, DC
额定电流 Rate current: 3.0A AC, DC
接触电阻 Contact resistance: $\leq 10m\Omega$
绝缘电阻 Insulation resistance: $\geq 1000m\Omega$
耐压 Voltage resisting: AC1000V.1min

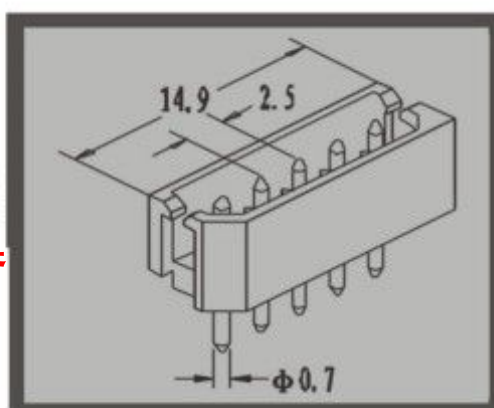

HAA250E-nA/5264-nA

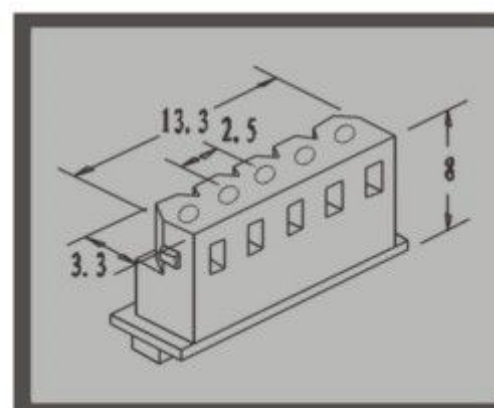

HAY250E-nY/5264-nY

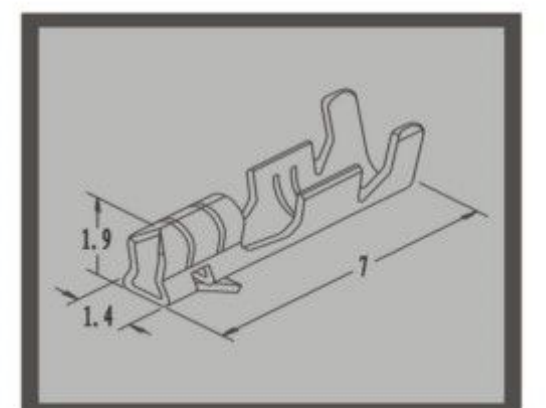

HAS250E-PT/HA2510-PT

连接器配件图

Connector Component

JPG 转 PDF 转换器 – 未注册版

如果您需要去掉这行字，请注册 JPG 转 PDF 转换器

连接器配件图

Connector Component

HA250G(5240)(5102)
主要技术特性: Main Specifications
间距 Pitch: 2.5mm
线数 Lines: 2-12
适合电线范围 Applicable wire range: AWG28#~22#
环境温度 Environment temperature: -25℃~+85℃
额定电压 Rate voltage: 250V AC, DC
额定电流 Rate current: 2.0A AC, DC
接触电阻 Contact resistance: $\leq 20m\Omega$
绝缘电阻 Insulation resistance: $\geq 1000m\Omega$
耐压 Voltage resisting: AC1000V.1min

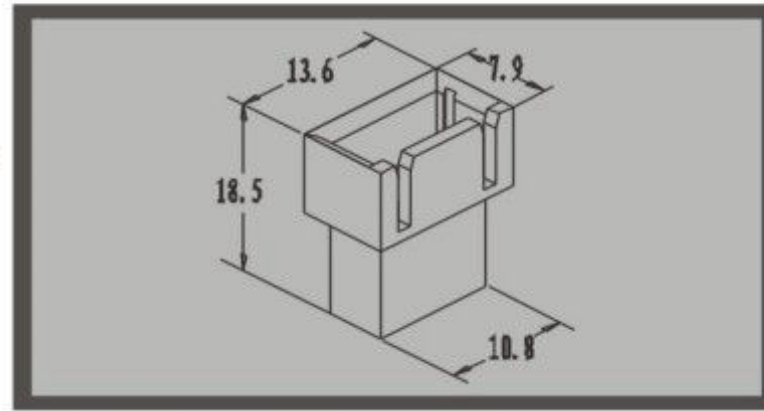

HA250G-nR/5240-nR

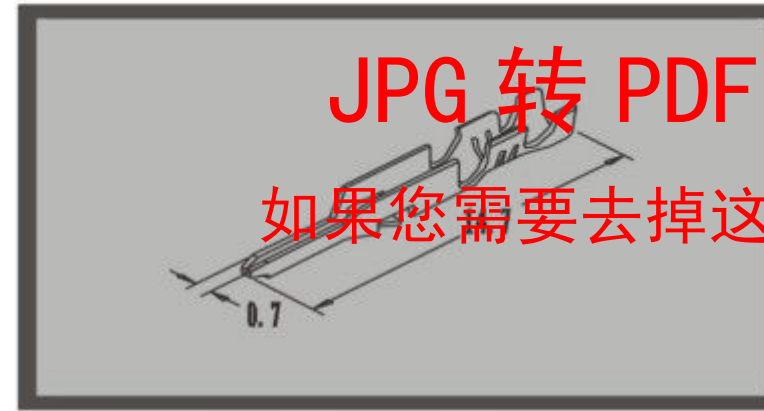

HA250G-RT/HA2513-RT

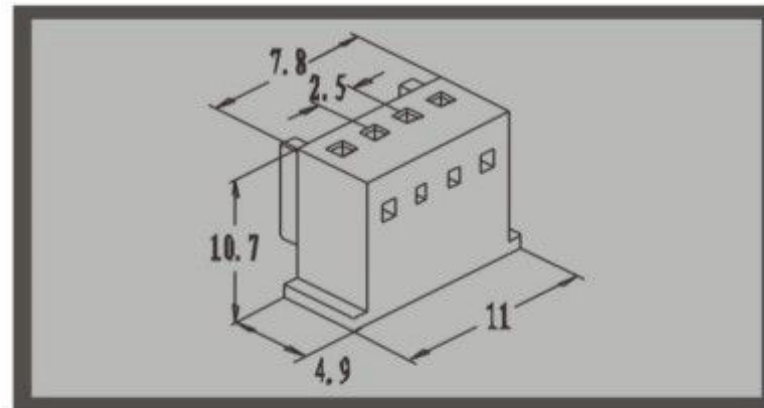

HA250G-nP/5102-nP

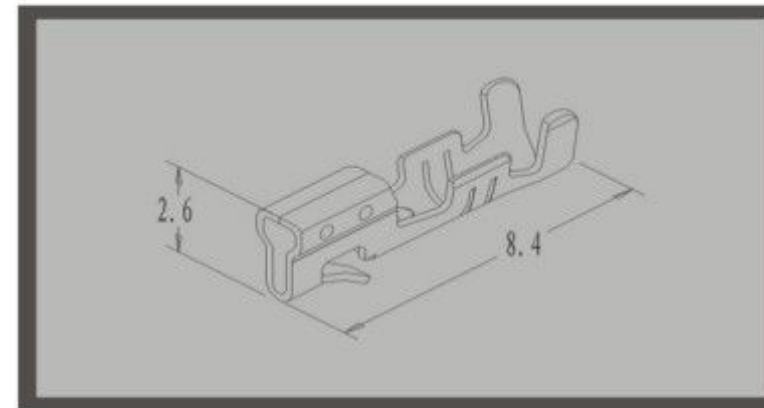

HA250G-PT/HA2513-PT

HA250H(SM)
主要技术特性: Main Specifications
间距 Pitch: 2.5mm
线数 Lines: 2-12
适合电线范围 Applicable wire range: AWG28#~22#
环境温度 Environment temperature: -25℃~+85℃
额定电压 Rate voltage: 250V AC, DC
额定电流 Rate current: 3.0A AC, DC
接触电阻 Contact resistance: $\leq 10m\Omega$
绝缘电阻 Insulation resistance: $\geq 100m\Omega$
耐压 Voltage resisting: AC1500V.1min

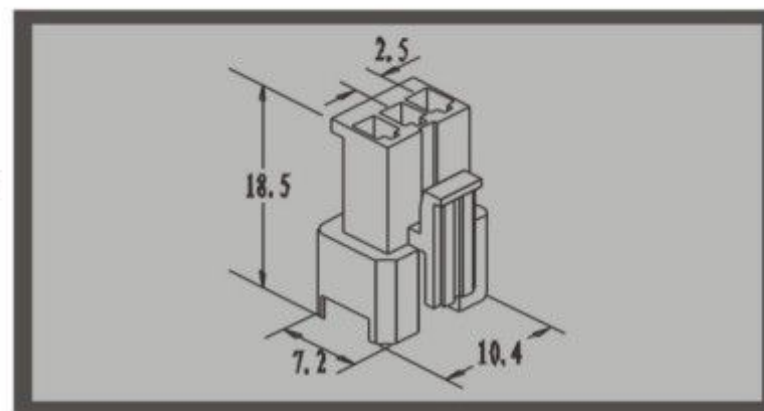

HA250H-nR/SM-nR

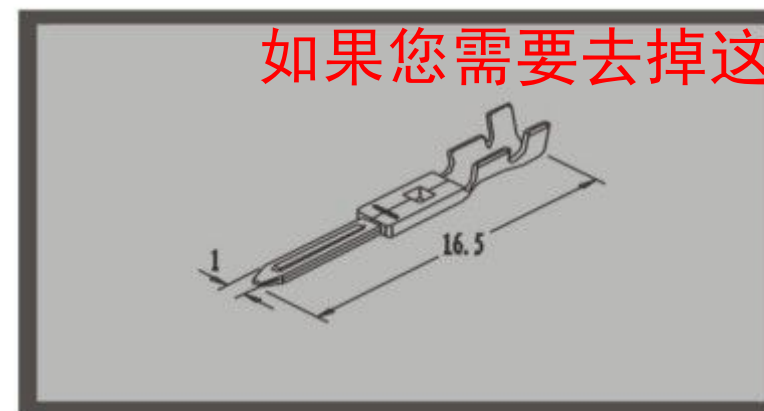

HA250H-RT/HA2514-RT

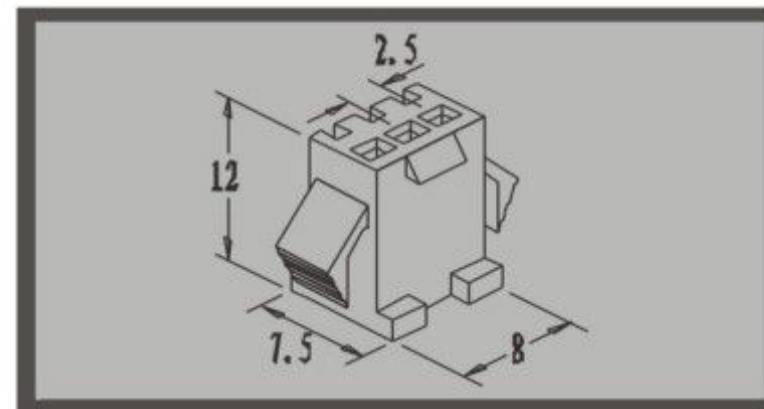

HA250H-nP/SM-nP

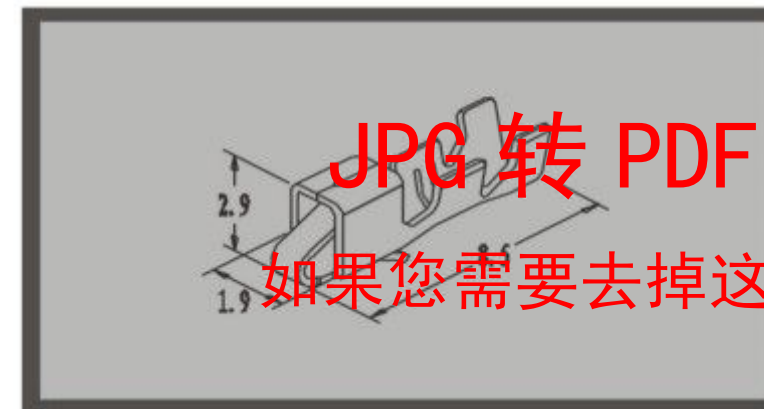

HA250H-PT/HA2514-PT

连接器配件图

Connector Component

HA250I(JVC)
主要技术特性: Main Specifications
间距 Pitch: 2.5mm
线数 Lines: 2-12
适合电线范围 Applicable wire range: AWG28#~22#
环境温度 Environment temperature: -25℃~+85℃
额定电压 Rate voltage: 250V AC, DC
额定电流 Rate current: 3.0A AC, DC
绝缘电阻 Insulation resistance: $\geq 1000m\Omega$
耐压 Voltage resisting: AC500V.1min

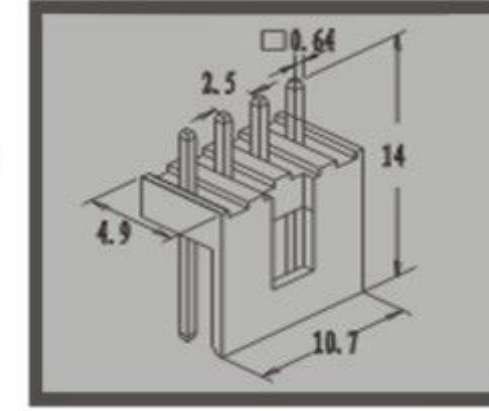

HAA250I-nA/JVC-nA

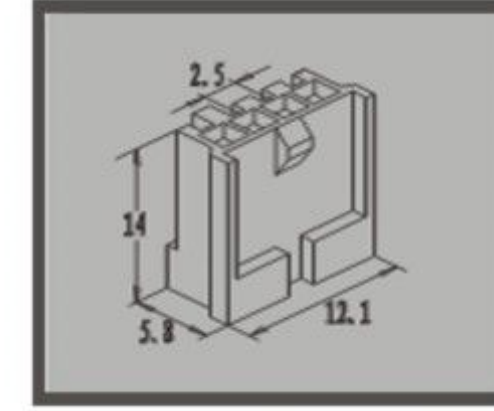

HAY250I-nY/JVC-nY

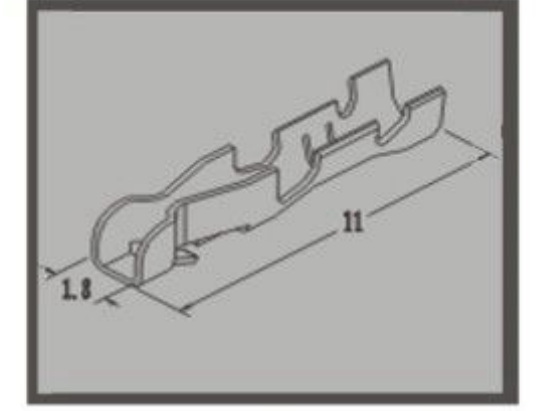

HAS250I-PT/JVC-PT

HA250J(250)
主要技术特性: Main Specifications
间距 Pitch: 2.5mm
线数 Lines: 2-13
适合电线范围 Applicable wire range: AWG28#~24#
环境温度 Environment temperature: -25℃~+85℃
额定电压 Rate voltage: 250V AC, DC
额定电流 Rate current: 3.0A AC, DC
接触电阻 Contact resistance: $\leq 10m\Omega$
绝缘电阻 Insulation resistance: $\geq 1000m\Omega$
耐压 Voltage resisting: AC1000V.1min

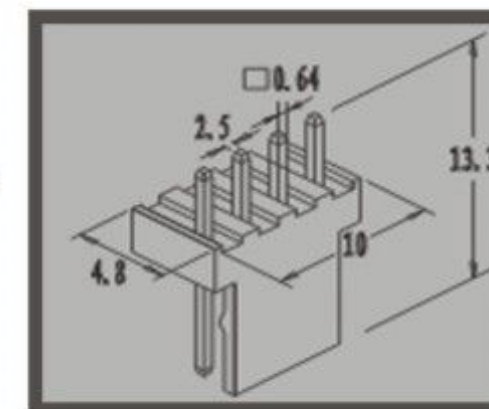

HA250J-nA/250-nA

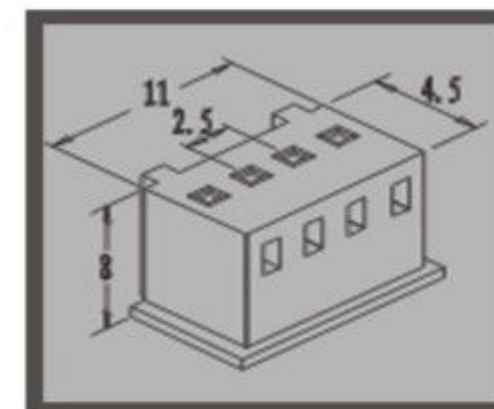

HA250J-nY/250-nY

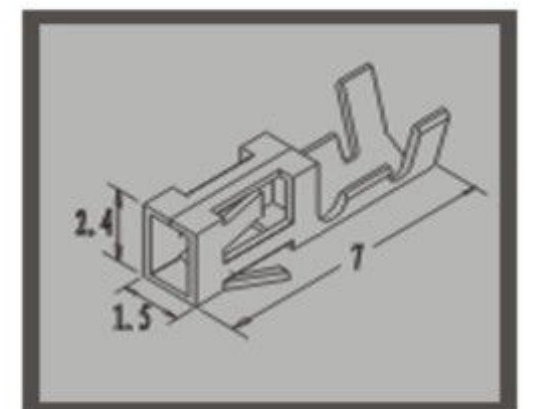

HAS250J-PT/250-PT

HA250M(MR)
主要技术特性: Main Specifications
间距 Pitch: 2.5mm
线数 Lines: 3-15
适合电线范围 Applicable wire range: AWG28#~22#
环境温度 Environment temperature: -25℃~+85℃
额定电压 Rate voltage: 250V AC, DC
额定电流 Rate current: 3.0A AC, DC
接触电阻 Contact resistance: $\leq 10m\Omega$
绝缘电阻 Insulation resistance: $\geq 1000m\Omega$
耐压 Voltage resisting: AC1000V.1min

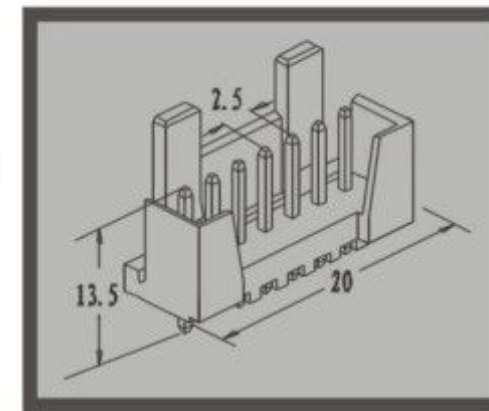

HA250M-nA/MR-nA

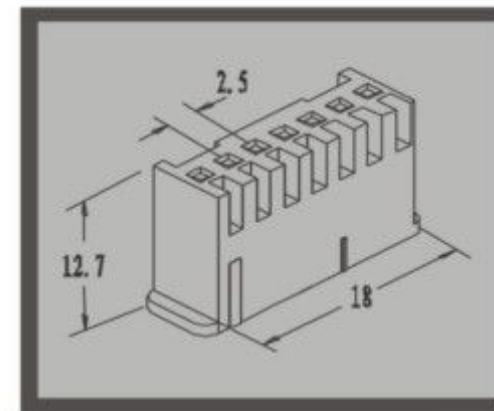

HA250M-nY/MR-nY

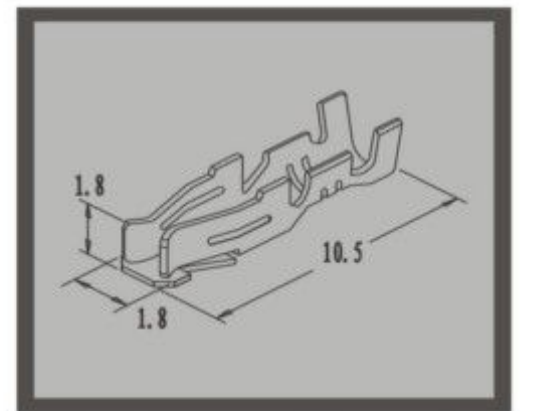

HA250M-PT/HA2511-PT

HA250P(LGC)
主要技术特性: Main Specifications
间距 Pitch: 2.5mm
线数 Lines: 3-15
适合电线范围 Applicable wire range: AWG28#~22#
环境温度 Environment temperature: -25℃~+85℃
额定电压 Rate voltage: 250V AC, DC
额定电流 Rate current: 3.0A AC, DC
接触电阻 Contact resistance: $\leq 10m\Omega$
绝缘电阻 Insulation resistance: $\geq 1000m\Omega$
耐压 Voltage resisting: AC1000V.1min

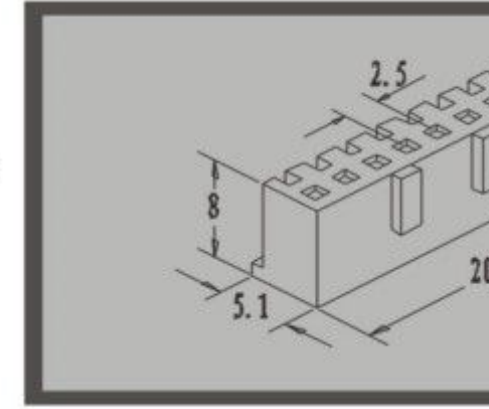

HA250P-n/LGC-nY

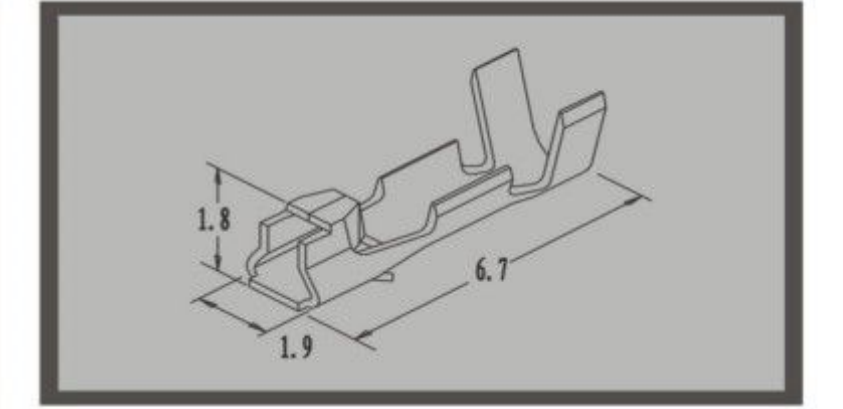

HA250P-PT

JPG 转 PDF 转换器 – 未注册版

如果您需要去掉这行字，请注册 JPG 转 PDF 转换器

连接器配件图

Connector Component

HA250Q(LGD)
主要技术特性: Main Specifications
间距 Pitch: 2.5mm
线数 Lines: 2-15
适合电线范围 Applicable wire range: AWG28#~22#
环境温度 Environment temperature: -25℃~+85℃
额定电压 Rate voltage: 250V AC, DC
额定电流 Rate current: 3.0A AC, DC
绝缘电阻 Insulation resistance: $\geq 1000m\Omega$
耐压 Voltage resisting: AC500V.1min

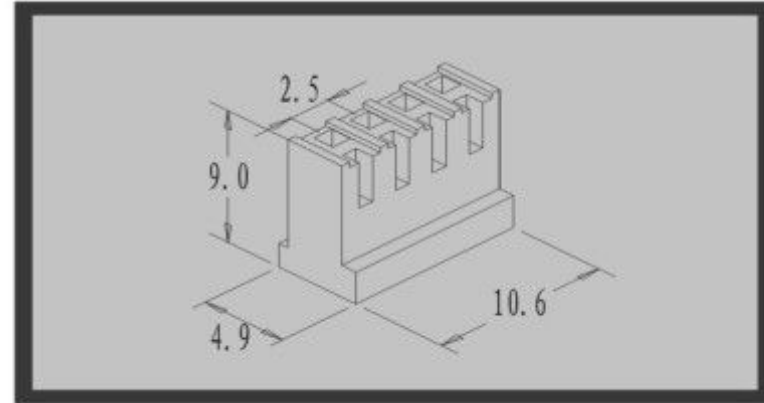

HA250Q-nY/LGD-nY

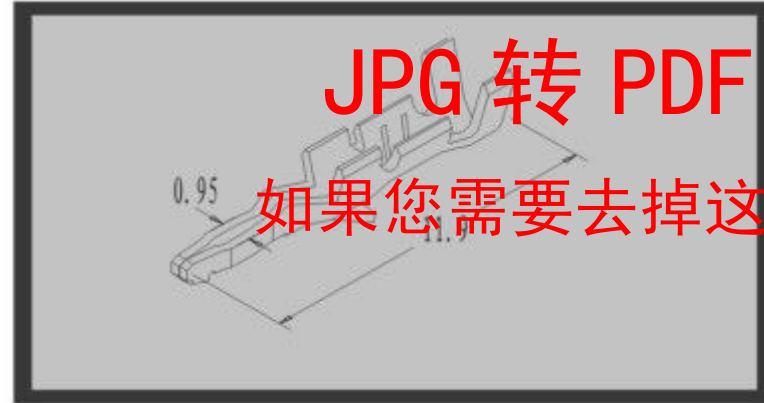

HA250Q-PT/HA2503-PT

HA254A(2510)
主要技术特性: Main Specifications
间距 Pitch: 2.54mm
线数 Lines: 2-20
适合电线范围 Applicable wire range: AWG28#~22#
环境温度 Environment temperature: -25℃~+85℃
额定电压 Rate voltage: 250V AC, DC
额定电流 Rate current: 3.0A AC, DC
接触电阻 Contact resistance: $\leq 20m\Omega$
绝缘电阻 Insulation resistance: $\geq 1000m\Omega$
耐压 Voltage resisting: AC1000V.1min

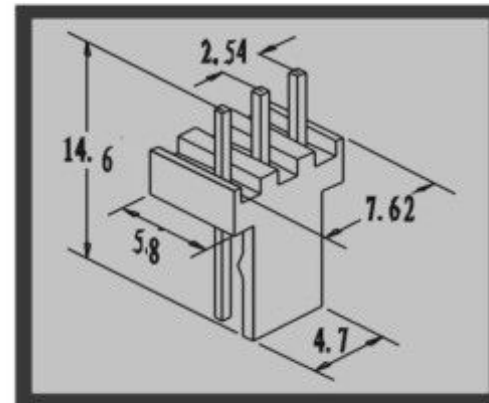

HA254A-n/5405-nA

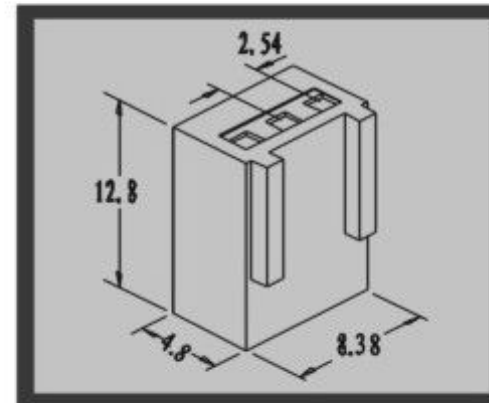

HA254A-n/5051-nY

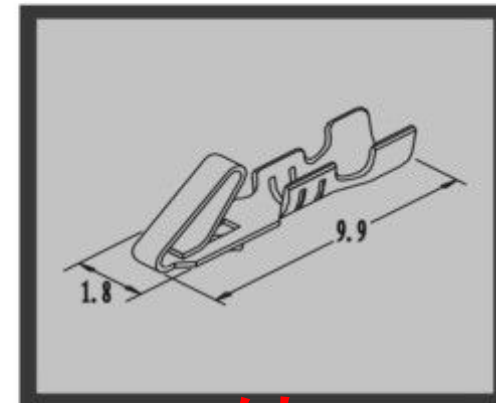

HA254A-PT/HA2542-PT

HA254B(TJC8)
主要技术特性: Main Specifications
间距 Pitch: 2.54mm
线数 Lines: 1-12 2-33
适合电线范围 Applicable wire range: AWG30#~24#
环境温度 Environment temperature: -40℃~+105℃
额定电压 Rate voltage: 250V AC, DC
额定电流 Rate current: 2.0A AC, DC
接触电阻 Contact resistance: $\leq 15m\Omega$
绝缘电阻 Insulation resistance: $\geq 1000m\Omega$
耐压 Voltage resisting: AC1500V.1min

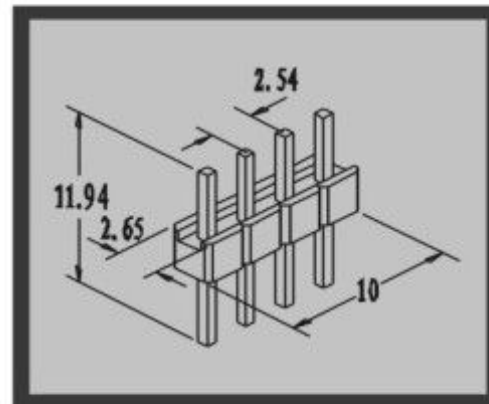

HA254B-nA

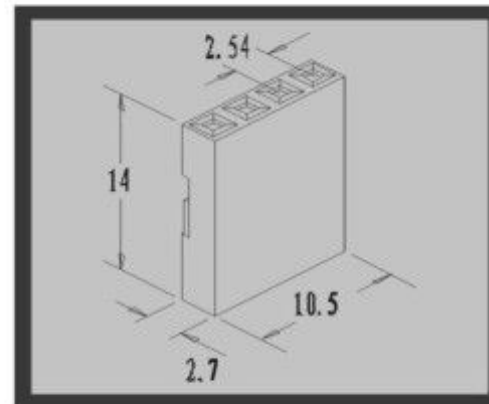

HA254B-nY

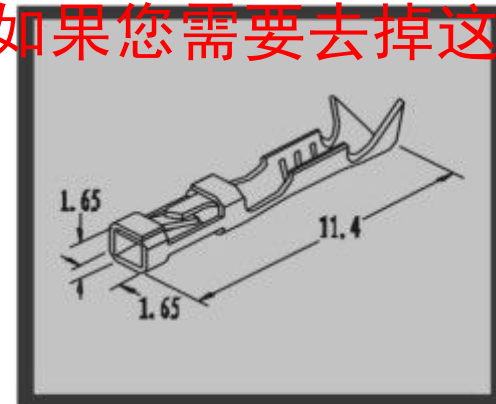

HA254-PT/HA2542-PT

HA254C(BB)
主要技术特性: Main Specifications
间距 Pitch: 2.54mm
线数 Lines: 1-4
适合电线范围 Applicable wire range: AWG30#~22#
环境温度 Environment temperature: -40℃~+105℃
额定电压 Rate voltage: 250V AC, DC
额定电流 Rate current: 3.0A AC, DC
接触电阻 Contact resistance: $\leq 10m\Omega$
绝缘电阻 Insulation resistance: $\geq 1000m\Omega$
耐压 Voltage resisting: AC1000V.1min

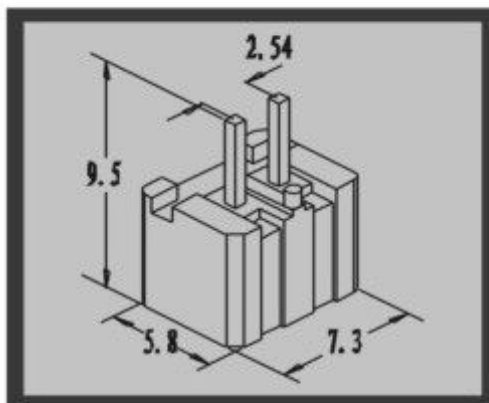

HA254C-nA

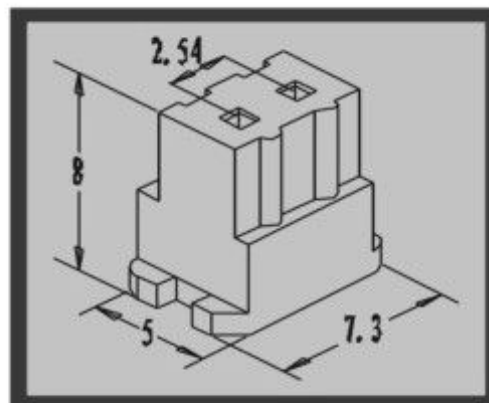

HA254C-nY



HA254C-PT

连接器配件图

Connector Component

HA300A(43645)
主要技术特性: Main Specifications
间距 Pitch: 3mm
线数 Lines: 2-6
适合电线范围 Applicable wire range: AWG30#~22#
环境温度 Environment temperature: -25℃~+85℃
额定电压 Rate voltage: 250V AC, DC
额定电流 Rate current: 3.0A AC, DC
接触电阻 Contact resistance: $\leq 20m\Omega$
绝缘电阻 Insulation resistance: $\geq 1000m\Omega$
耐压 Voltage resisting: AC1500V.1min

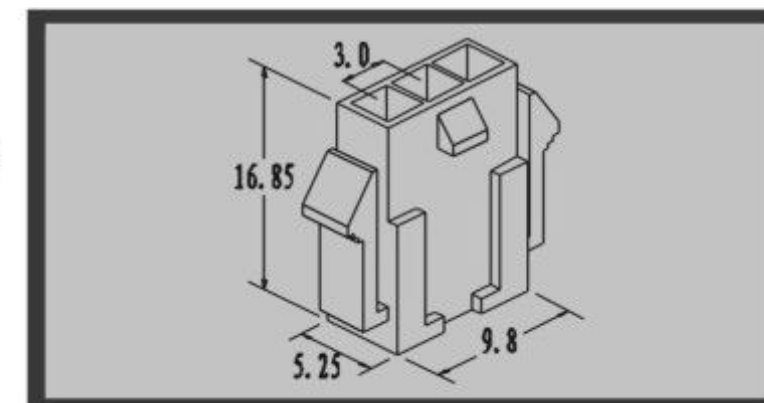

HA300A-nR/43020-nR

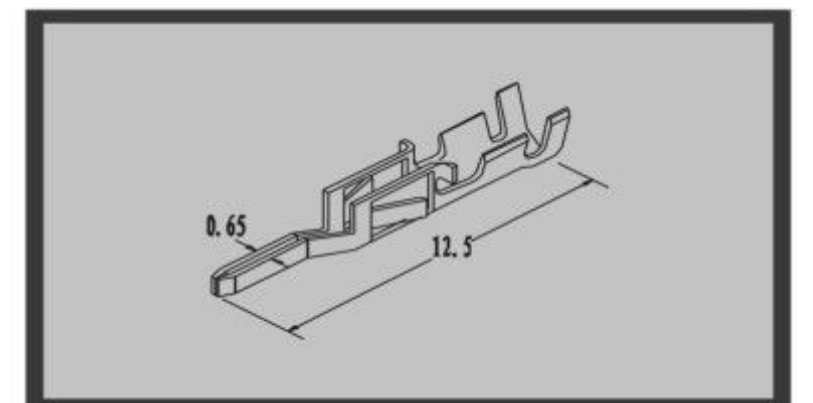

HA300A-RT/43031

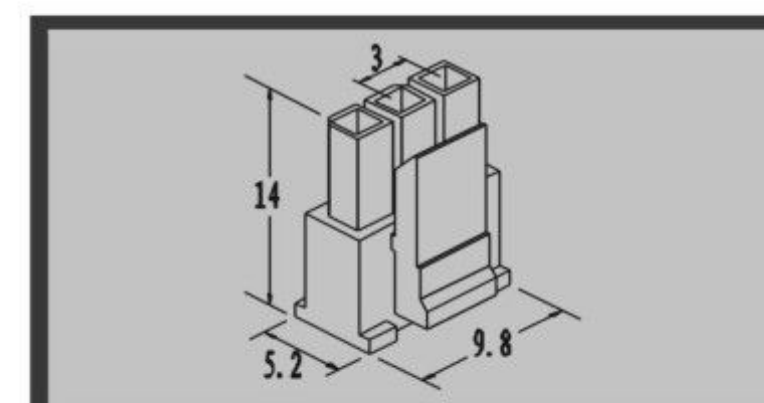

HA300A-nP/43025-nP

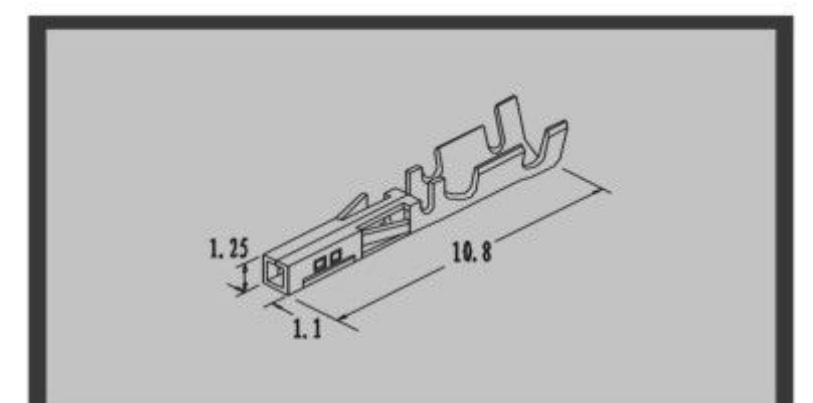

HA300A-PT/43030

HA370A(5600) (BB)
主要技术特性: Main Specifications
间距 Pitch: 3.7mm
线数 Lines: 2-3
适合电线范围 Applicable wire range: AWG24#~18#
环境温度 Environment temperature: -25℃~+85℃
额定电压 Rate voltage: 250V AC, DC
额定电流 Rate current: 5.0A AC, DC
接触电阻 Contact resistance: $\leq 20m\Omega$
绝缘电阻 Insulation resistance: $\geq 1000m\Omega$
耐压 Voltage resisting: AC1500V.1min

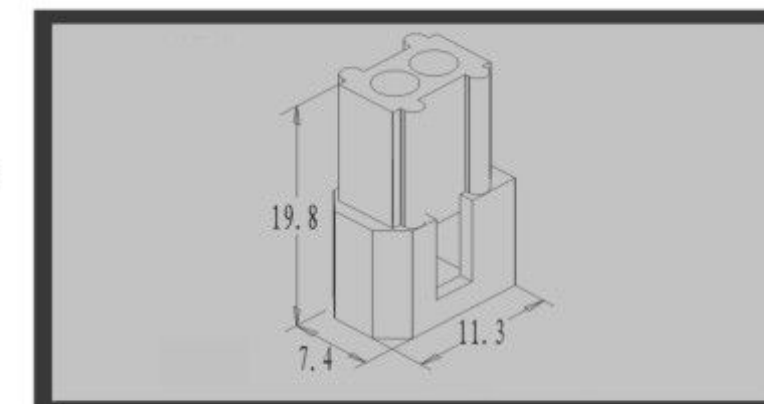

HA370A-nR/5600-nR

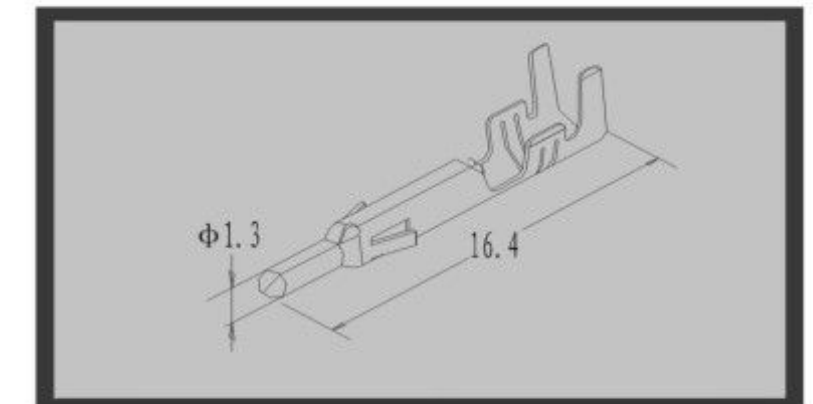

HA370A-RT/5600-RT

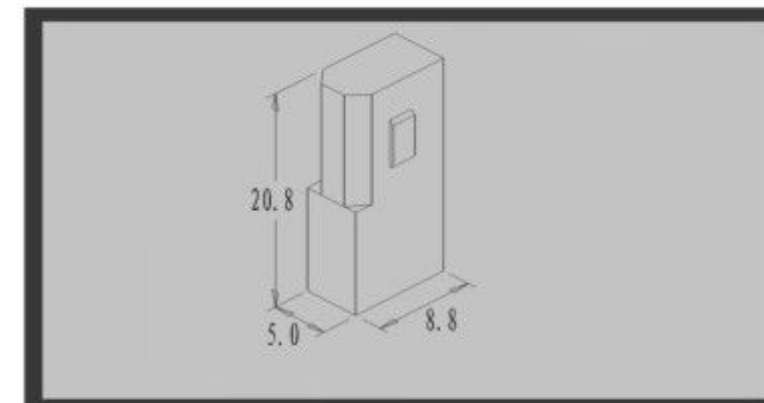

HA370A-nP/5500-nP

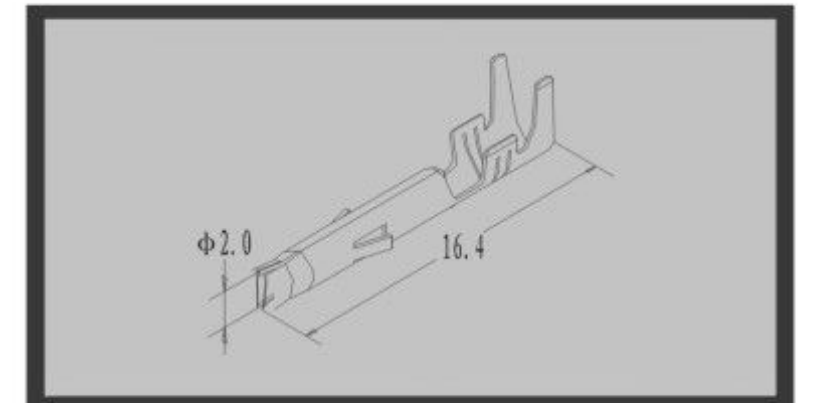

HA370A-PT/5500-PT

JPG 转 PDF 转换器 – 未注册版

如果您需要去掉这行字，请注册 JPG 转 PDF 转换器

连接器配件图

Connector Component

HA396A(VH)
主要技术特性: Main Specifications
间距 Pitch: 3.96mm
线数 Lines: 2-10
适合电线范围 Applicable wire range: AWG22#-16#
环境温度 Environment temperature: -25℃~+85℃
额定电压 Rate voltage: 250V AC, DC
额定电流 Rate current: 5.0A AC, DC
接触电阻 Contact resistance: ≤ 10mΩ
绝缘电阻 Insulation resistance: ≥ 1000mΩ
耐压 Voltage resisting: AC1500V.1min

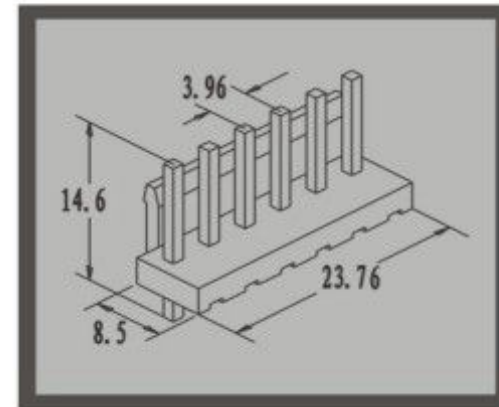

HA396A-nA/VH-nA

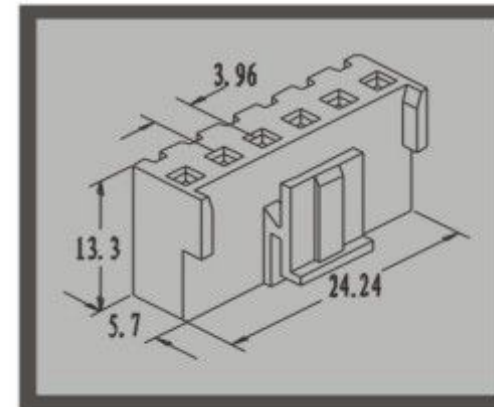

HA396A-nY/VH-nY

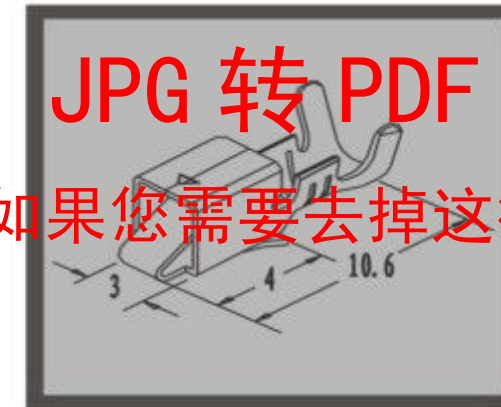

HA396A-PT/VH-PT

HA396B(5195)
主要技术特性: Main Specifications
间距 Pitch: 3.96mm
线数 Lines: 2-12
适合电线范围 Applicable wire range: AWG24#-18#
环境温度 Environment temperature: -25℃~+85℃
额定电压 Rate voltage: 250V AC, DC
额定电流 Rate current: 5.0A AC, DC
接触电阻 Contact resistance: ≤ 10mΩ
绝缘电阻 Insulation resistance: ≥ 1000mΩ
耐压 Voltage resisting: AC1500V.1min

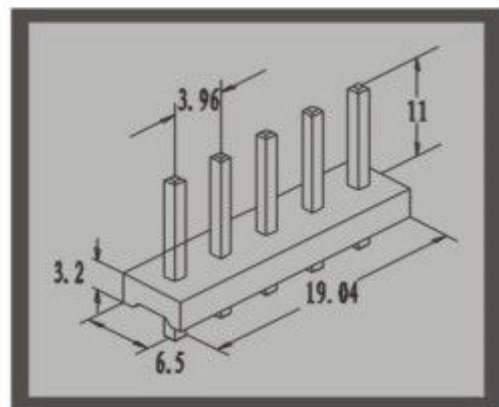

HAA396B-n/5273-nY

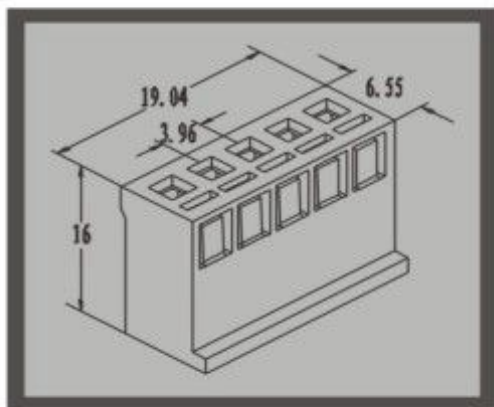

HAY396B-n/5195-nY

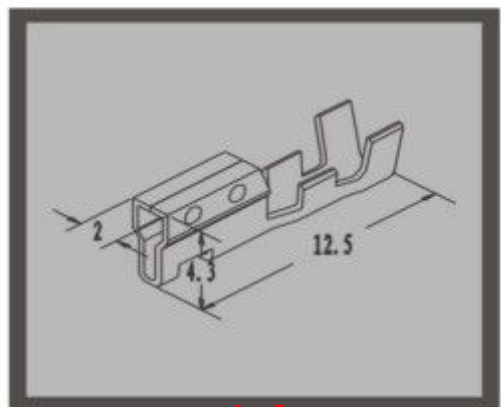

HAA396B-PT/5273-PT

HA396C(3.96)
主要技术特性: Main Specifications
间距 Pitch: 3.96mm
线数 Lines: 2-16
适合电线范围 Applicable wire range: AWG28#-22#
环境温度 Environment temperature: -25℃~+85℃
额定电压 Rate voltage: 250V AC, DC
额定电流 Rate current: 5.0A AC, DC
接触电阻 Contact resistance: ≤ 10mΩ
绝缘电阻 Insulation resistance: ≥ 1000mΩ
耐压 Voltage resisting: AC1500V.1min

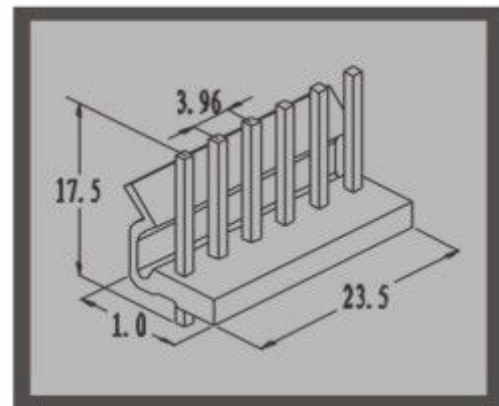

HAA396C-n

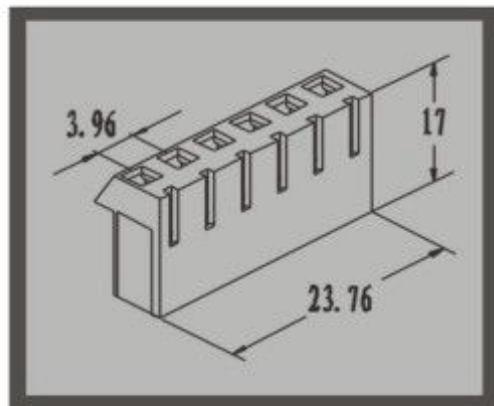

HAY396C-n/3069-nY

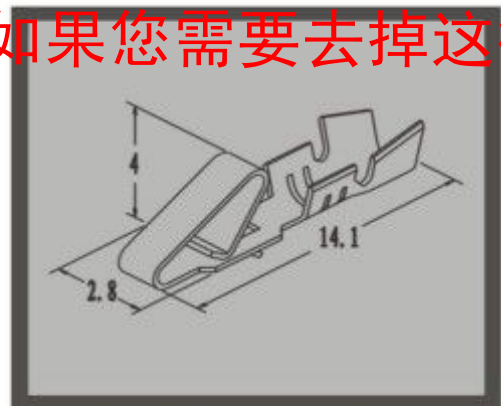

HAS396C-PT

HA1188A(VTR)
主要技术特性: Main Specifications
间距 Pitch: 11.88mm
线数 Lines: 2
适合电线范围 Applicable wire range: AWG20#-16#
环境温度 Environment temperature: -25℃~+85℃
额定电压 Rate voltage: 250V AC, DC
额定电流 Rate current: 12A AC, DC
接触电阻 Contact resistance: ≤ 10mΩ
绝缘电阻 Insulation resistance: ≥ 1000mΩ
耐压 Voltage resisting: AC1500V.1min

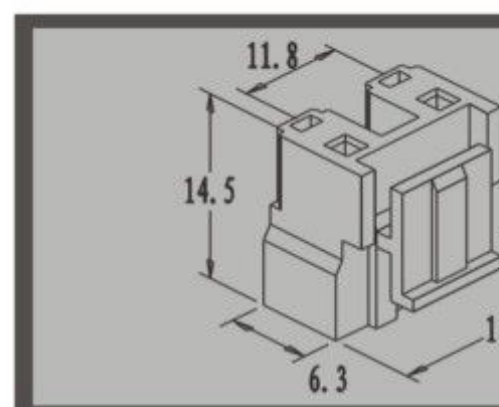

HAY1188A-2/VTR-2Y

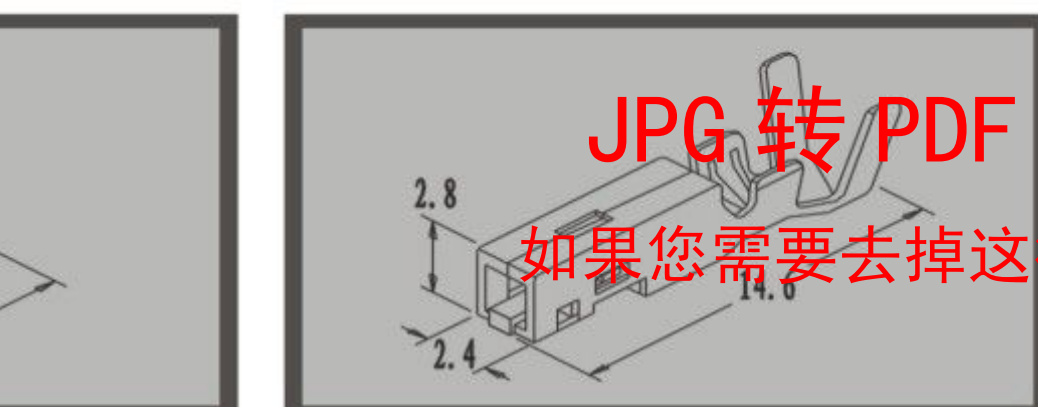

HAS1188A-PT/HA1201-PT

连接器配件图

Connector Component

HA414A(FL)
主要技术特性: Main Specifications
间距 Pitch: 4.4mm
线数 Lines: 1-4, 6, 9, 12, 15
适合电线范围 Applicable wire range: AWG26#-22#
环境温度 Environment temperature: -25℃~+85℃
额定电压 Rate voltage: 300V AC, DC
额定电流 Rate current: 5.0A AC, DC
接触电阻 Contact resistance: ≤ 15mΩ
绝缘电阻 Insulation resistance: ≥ 1000mΩ
耐压 Voltage resisting: AC1500V.1min

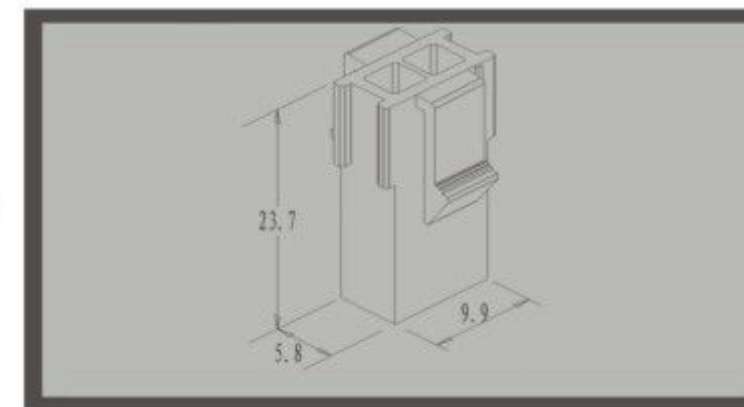

HAA414A-nR/FL-nR

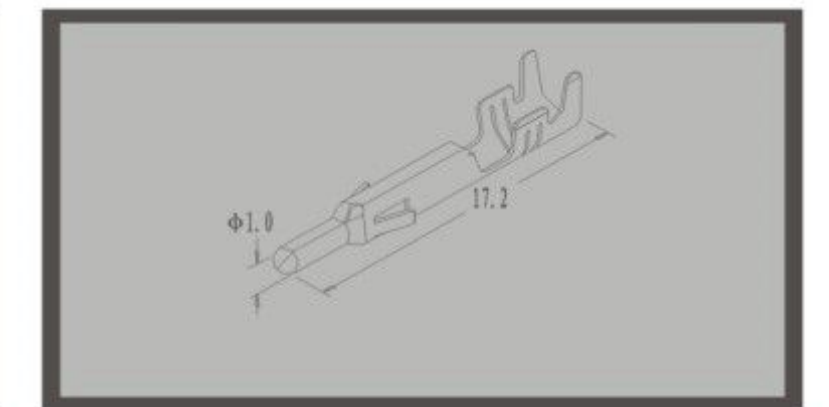

HAA414A-RT/FL-RT

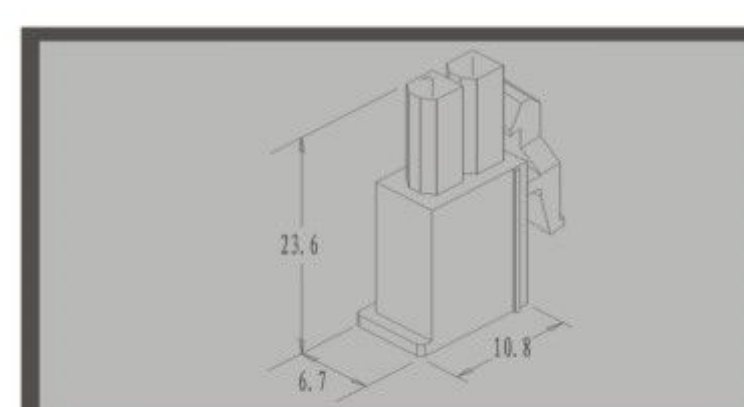

HAA414A-nP/FL-nP

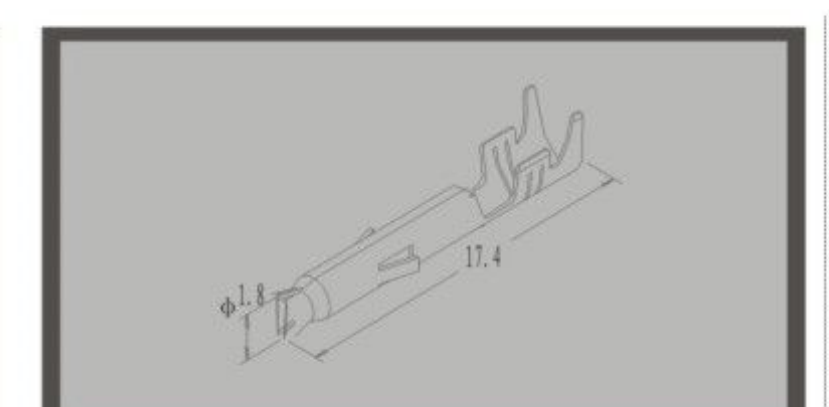

HAA414A-PT/FL-PT

HA420A(5557)
主要技术特性: Main Specifications
间距 Pitch: 4.2mm
线数 Lines: 4-24
适合电线范围 Applicable wire range: AWG24#-18#
环境温度 Environment temperature: -25℃~+85℃
额定电压 Rate voltage: 250V AC, DC
额定电流 Rate current: 7.0A AC, DC
接触电阻 Contact resistance: ≤ 10mΩ
绝缘电阻 Insulation resistance: ≥ 1000mΩ
耐压 Voltage resisting: AC1500V.1min

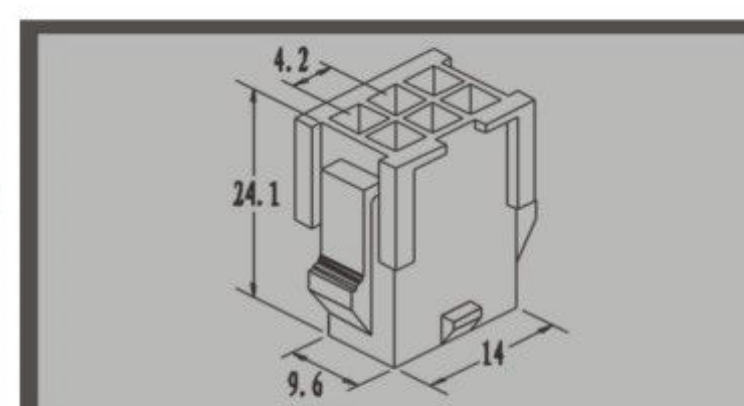

HAA420A-n/5559-nA

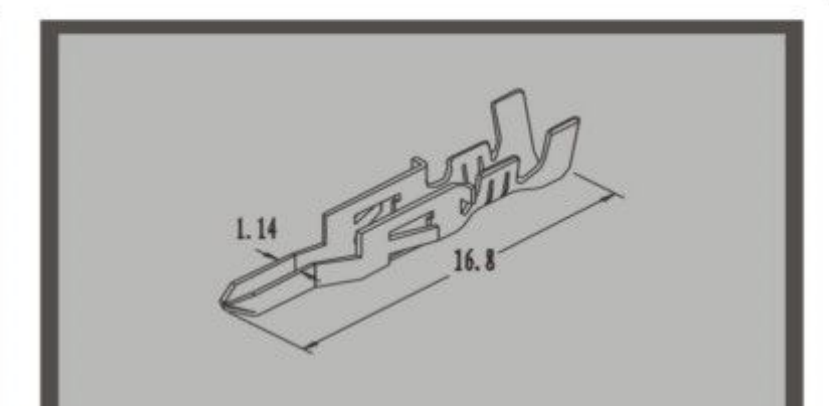

HAS420A-RT/(5558)

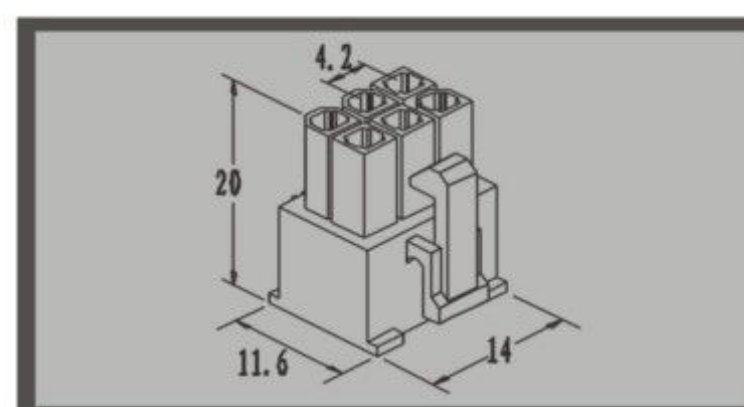

HAY420A-n/5557-nY

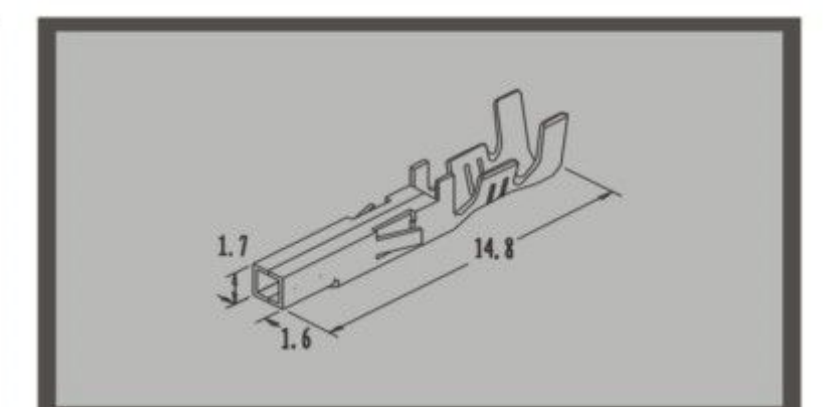

HAS420A-PT/5558

JPG 转 PDF 转换器 – 未注册版

如果您需要去掉这行字，请注册 JPG 转 PDF 转换器

连接器配件图

Connector Component

HA450A(EL)
主要技术特性: Main Specifications
间距 Pitch: 4.5mm
线数 Lines: 2-15
适合电线范围 Applicable wire range: AWG26#-16#
环境温度 Environment temperature: -25℃~+85℃
额定电压 Rate voltage: 300V AC, DC
额定电流 Rate current: 10A AC, DC
接触电阻 Contact resistance: $\leq 10m\Omega$
绝缘电阻 Insulation resistance: $\geq 1000m\Omega$
耐压 Voltage resisting: AC1500V.1min

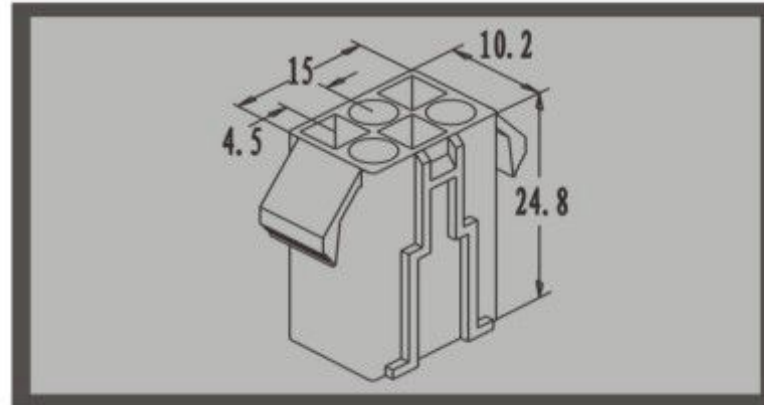

HAA450A-n/EL/nA

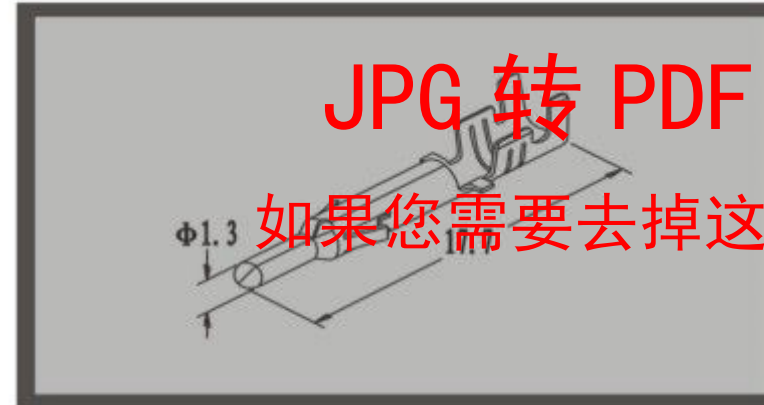

HAS450A-RT/EL-RT

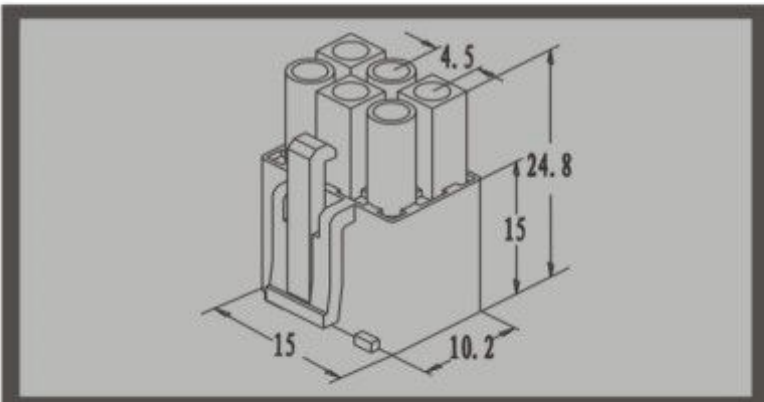

HAY450A-n/EL/nY

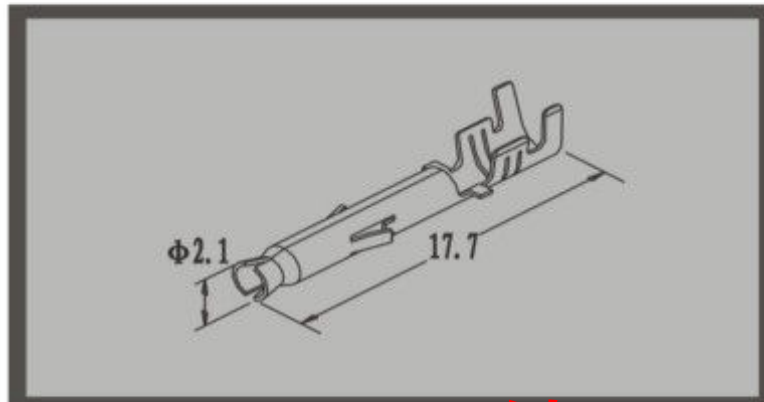

HAS450A-PT/EL-PT

HA450B(YL)
主要技术特性: Main Specifications
间距 Pitch: 4.5mm
线数 Lines: 1-21
适合电线范围 Applicable wire range: AWG26#-16
环境温度 Environment temperature: -25℃~+85℃
额定电压 Rate voltage: 300V AC, DC
额定电流 Rate current: 10A AC, DC
接触电阻 Contact resistance: $\leq 7m\Omega$
绝缘电阻 Insulation resistance: $\geq 1000m\Omega$
耐压 Voltage resisting: AC1500V.1min

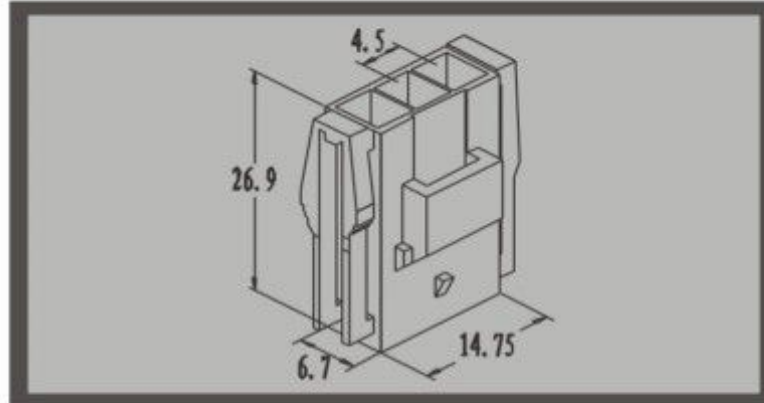

HAA450B-n/YL/nA

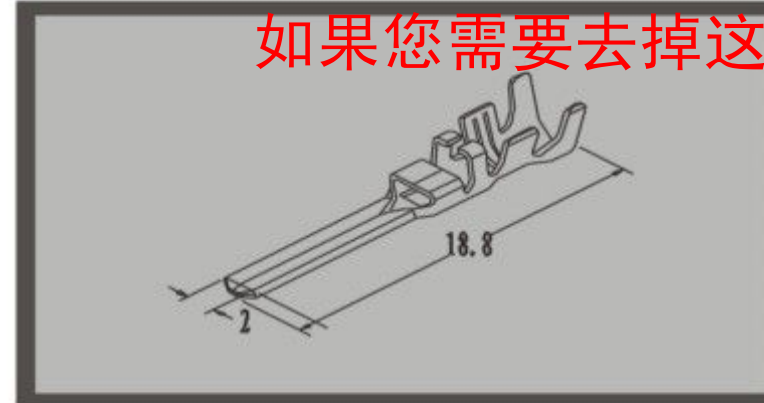

HAS450B-RT/YL-RT

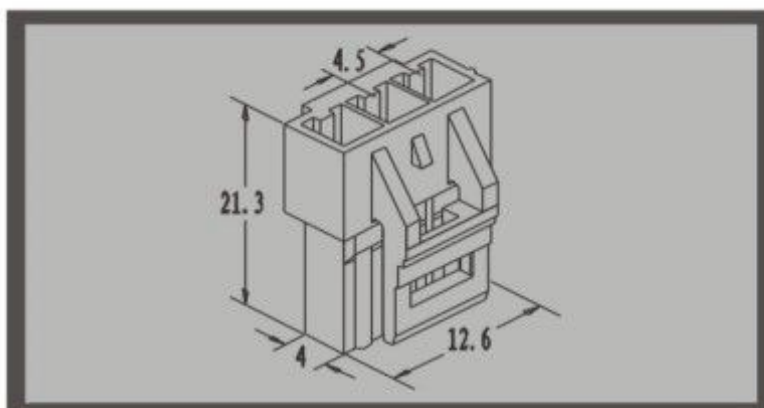

HAY450B-n/YL-nY

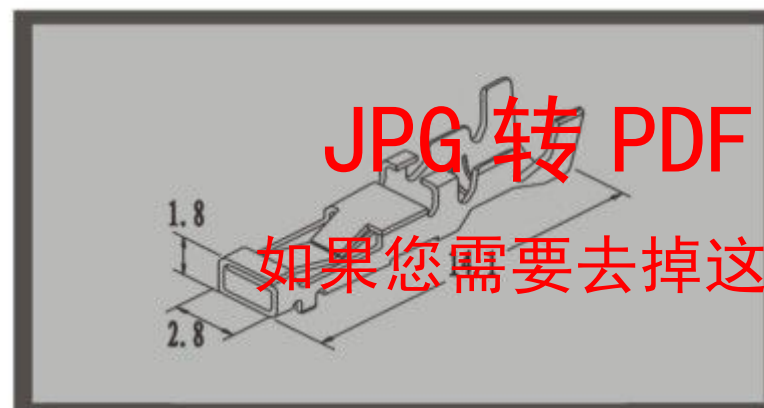

HAS450B-PT/YL-PT

连接器配件图

Connector Component

HA508B(TJC10)
主要技术特性: Main Specifications
间距 Pitch: 5.08mm
线数 Lines: 4
适合电线范围 Applicable wire range: AWG22#-16#
环境温度 Environment temperature: -25℃~+85℃
额定电压 Rate voltage: 250V AC, DC
额定电流 Rate current: 5.0A AC, DC
接触电阻 Contact resistance: $\leq 10m\Omega$
绝缘电阻 Insulation resistance: $\geq 1000m\Omega$
耐压 Voltage resisting: AC1500V.1min

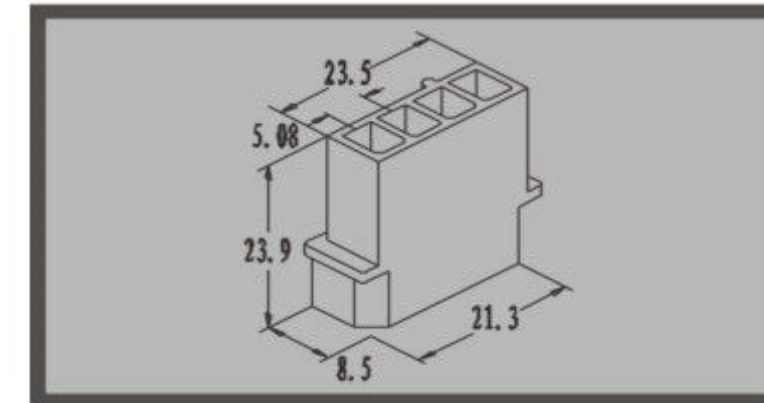

HAA508B-4

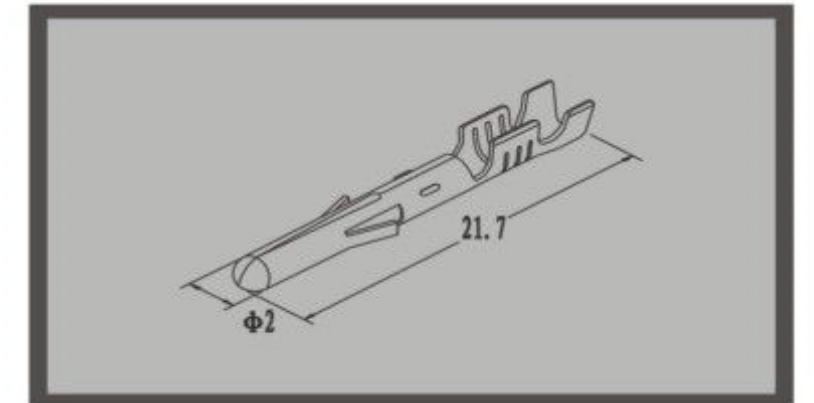

HAS508B-RT

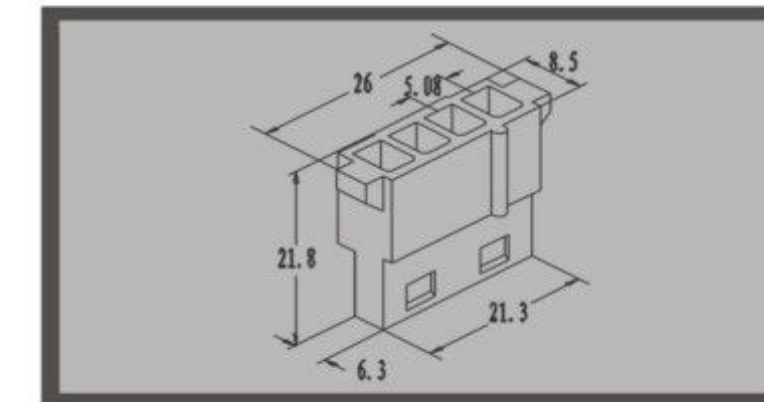

HAY508B-4

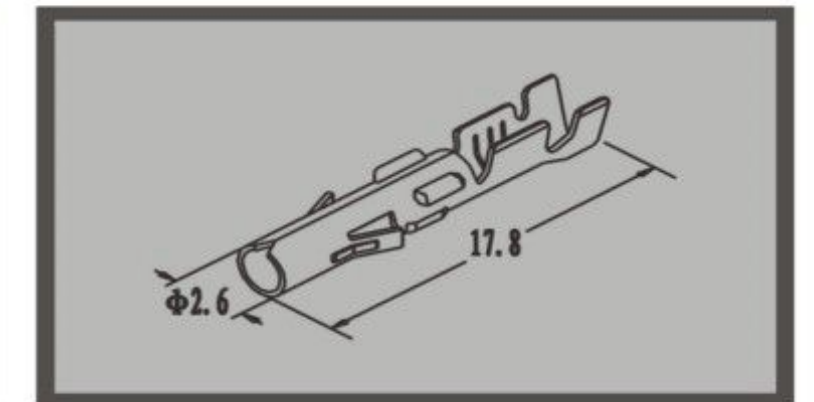

HAS508B-PT

HA620B(LS2)
主要技术特性: Main Specifications
间距 Pitch: 6.2mm
线数 Lines: 2-9
适合电线范围 Applicable wire range: AWG26#-16
环境温度 Environment temperature: -25℃~+85℃
额定电压 Rate voltage: 300V AC, DC
额定电流 Rate current: 10A AC, DC
接触电阻 Contact resistance: $\leq 10m\Omega$
绝缘电阻 Insulation resistance: $\geq 1000m\Omega$
耐压 Voltage resisting: AC1500V.1min

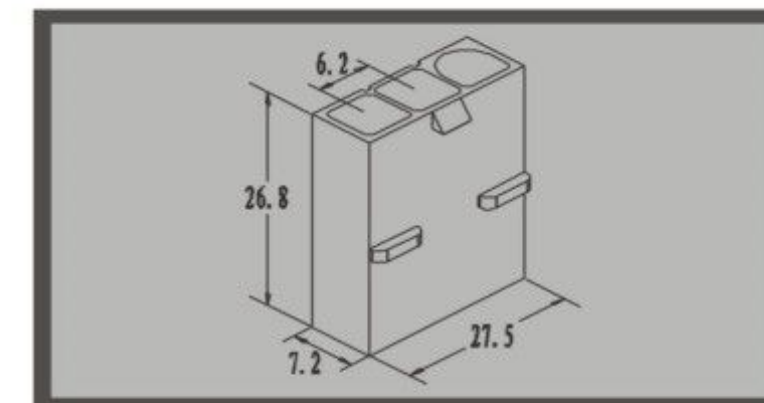

HAA620B-n

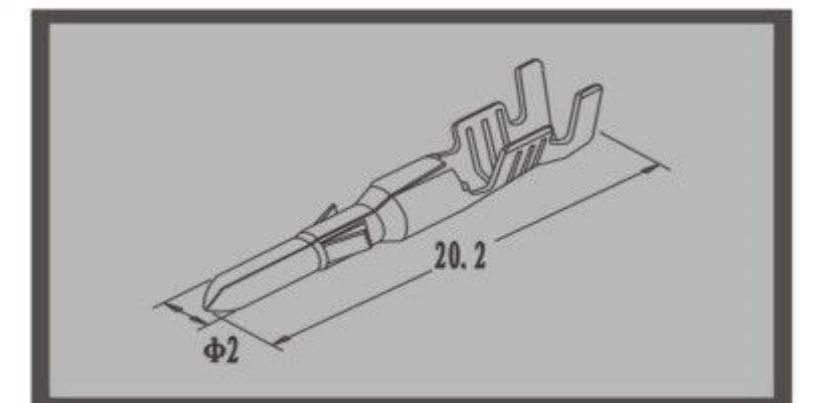

HAS620B-RT

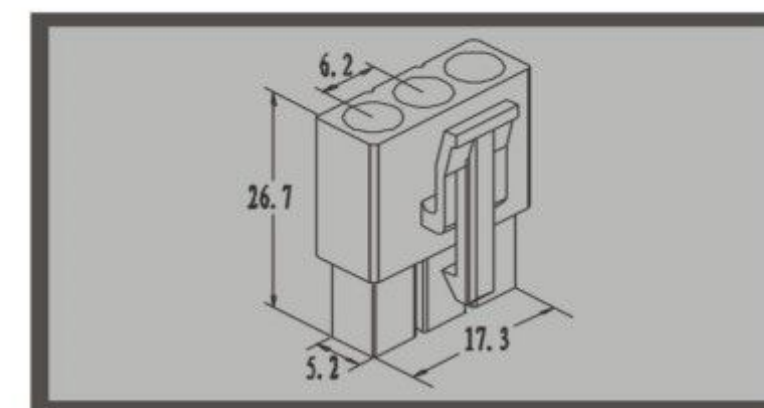

HAY620B-n

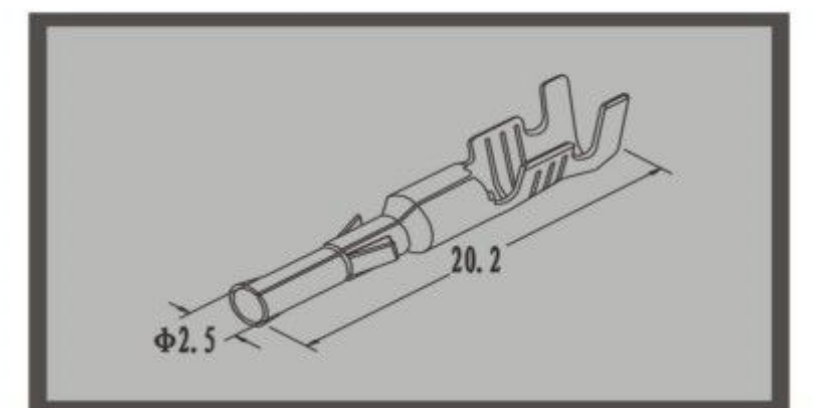

HAS620B-PT

JPG 转 PDF 转换器 - 未注册版

如果您需要去掉这行字, 请注册 JPG 转 PDF 转换器

连接器配件图

Connector Component

HA630A
主要技术特性: Main Specifications
间距 Pitch: 6.3mm
线数 Lines: 2、3、4、6、9
适合电线范围 Applicable wire range: AWG20#~1#
环境温度 Environment temperature: -25℃~+105℃
额定电压 Rate voltage: 300V AC, DC
额定电流 Rate current: 8.0A AC, DC
接触电阻 Contact resistance: ≤10mΩ
绝缘电阻 Insulation resistance: ≥1000mΩ
耐压 Voltage resisting: AC1500V.1min

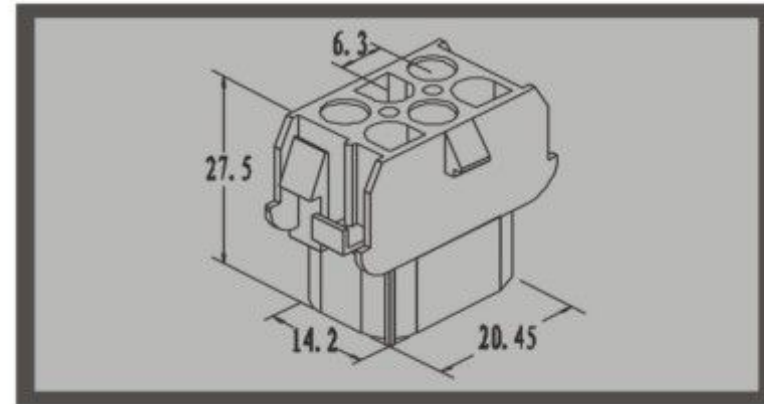

HAA630A-n

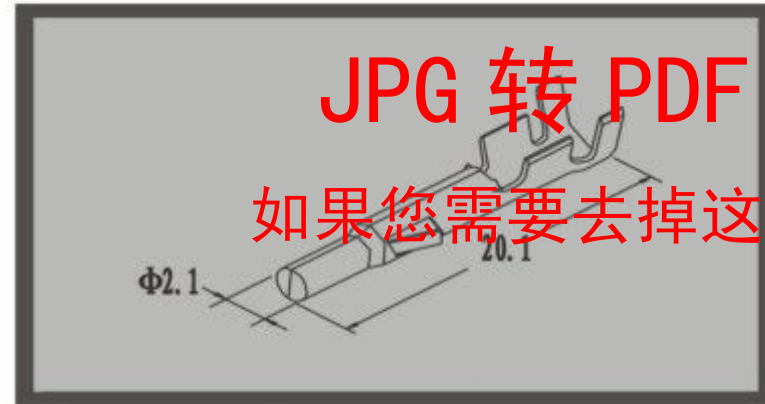

HAS630A-PT

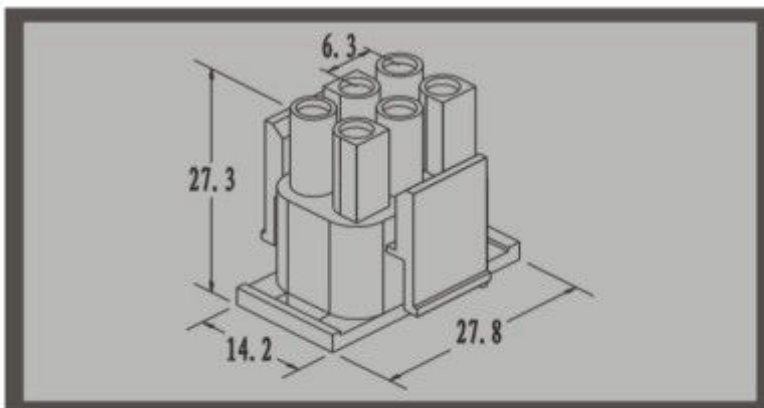

HAY630A-n

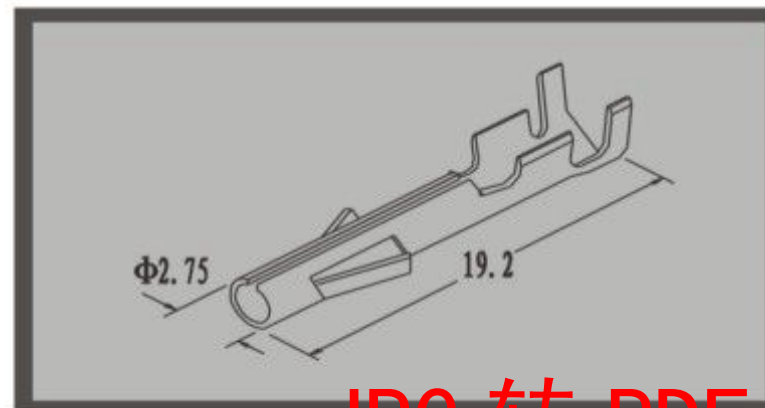

HAS630A-PT

HA670A (3191)
主要技术特性: Main Specifications
间距 Pitch: 6.7mm
线数 Lines: 2-15
适合电线范围 Applicable wire range: AWG20#~14#
环境温度 Environment temperature: -40℃~+105℃
额定电压 Rate voltage: 600V AC, DC
额定电流 Rate current: 12A AC, DC
接触电阻 Contact resistance: ≤20mΩ
绝缘电阻 Insulation resistance: ≥1000mΩ
耐压 Voltage resisting: AC5000V.1min

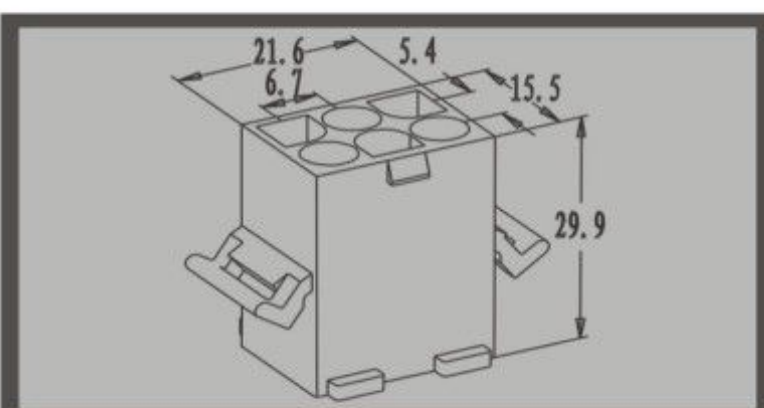

HAA670A-n

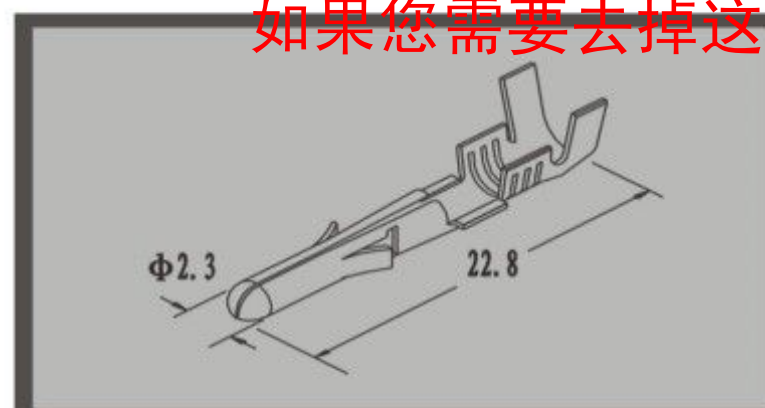

HAS670A-PT

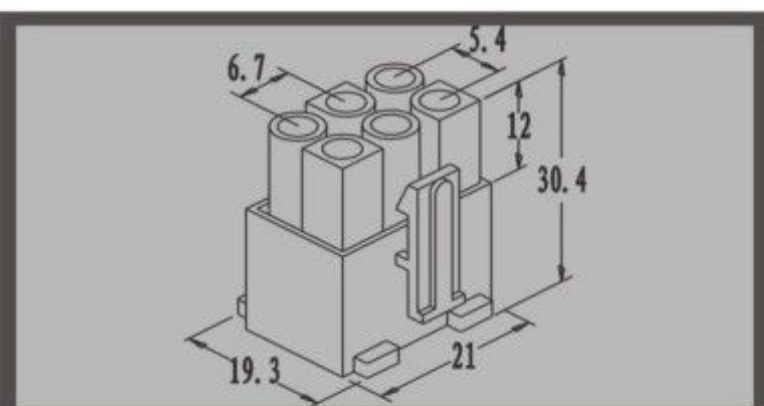

HAY670A-n

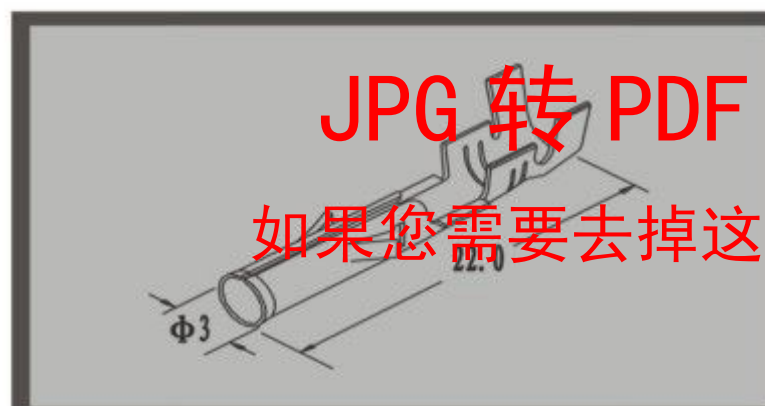

HAS670A-PT

连接器配件图

Connector Component

HA750-500A (TJC2)
主要技术特性: Main Specifications
间距 Pitch: 5-5.5mm
线数 Lines: 1-6
适合电线范围 Applicable wire range: AWG26#~2
环境温度 Environment temperature: -25℃~+85℃
额定电压 Rate voltage: 250V AC, DC
额定电流 Rate current: 5.0A AC, DC
接触电阻 Contact resistance: ≤10mΩ
绝缘电阻 Insulation resistance: ≥1000mΩ
耐压 Voltage resisting: AC1500V.1min

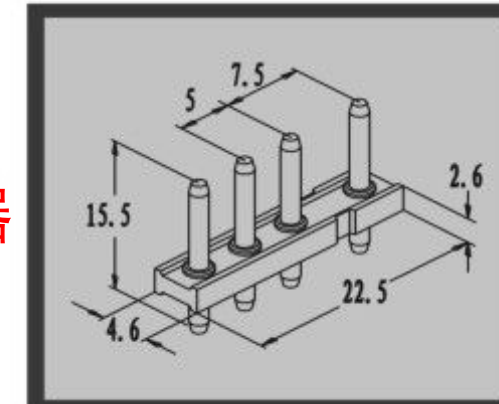

HAA750-500A-nA

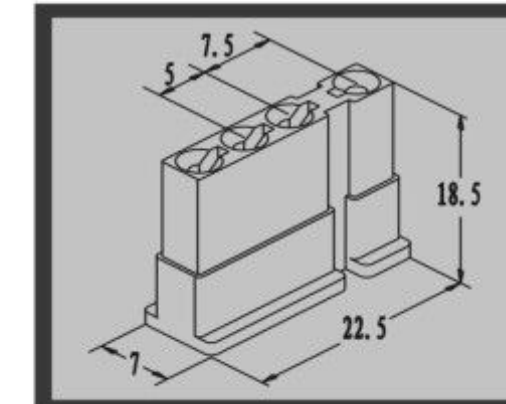

HAY750-500A-nY

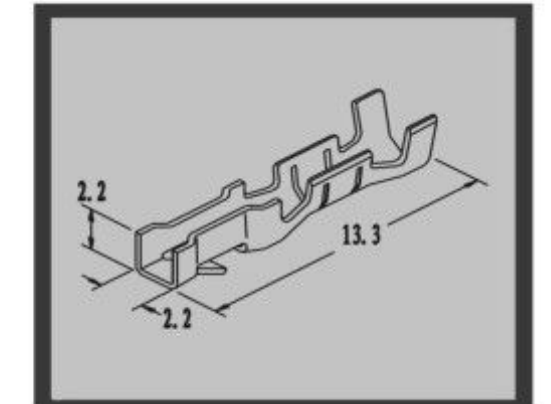

HAS750-500A-PT

HA750-500B(TJC2C)
主要技术特性: Main Specifications
间距 Pitch: 7.5-5mm
线数 Lines: 1-6
适合电线范围 Applicable wire range: AWG26#~20#
环境温度 Environment temperature: -25℃~+85℃
额定电压 Rate voltage: 250V AC, DC
额定电流 Rate current: 5.0A AC, DC
接触电阻 Contact resistance: ≤10mΩ
绝缘电阻 Insulation resistance: ≥1000mΩ
耐压 Voltage resisting: AC1500V.1min

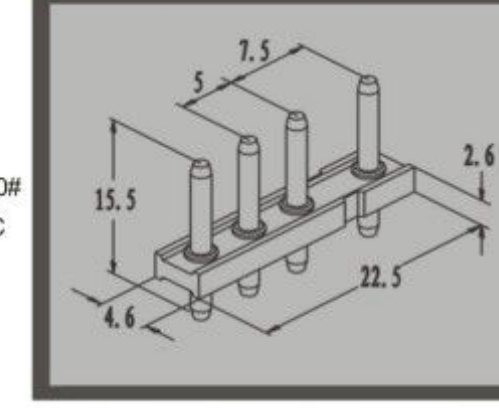

HAA750-500B-nA

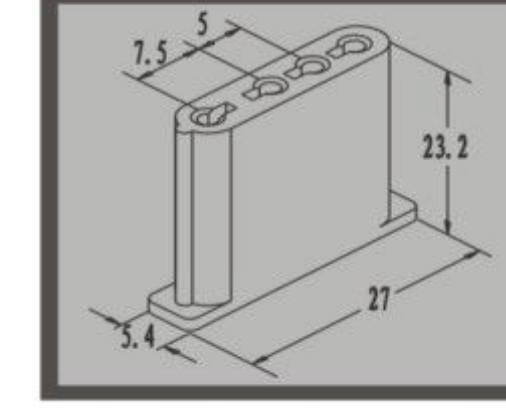

HAY750-500B-nY

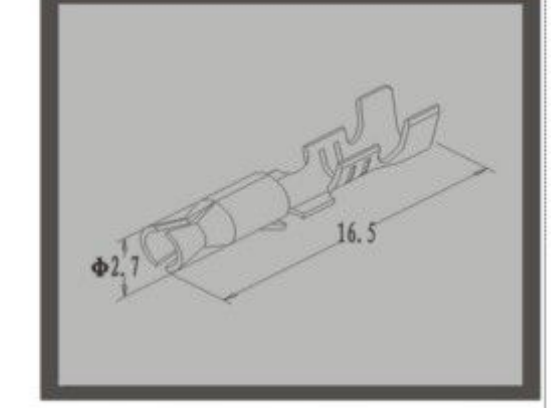

HAS750-500B-PT

HA800B(X20B)
主要技术特性: Main Specifications
间距 Pitch: 8.0mm
线数 Lines: 1-3
适合电线范围 Applicable wire range: AWG24#~20#
环境温度 Environment temperature: -25℃~+85℃
额定电压 Rate voltage: 100V AC, DC
额定电流 Rate current: 6.0A AC, DC
接触电阻 Contact resistance: ≤20mΩ
绝缘电阻 Insulation resistance: ≥1000mΩ
耐压 Voltage resisting: AC1500V.1min

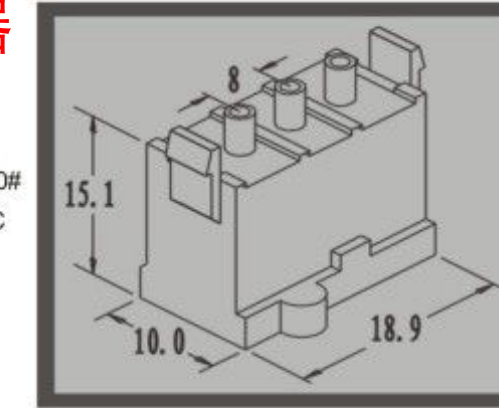

HAA800B-n

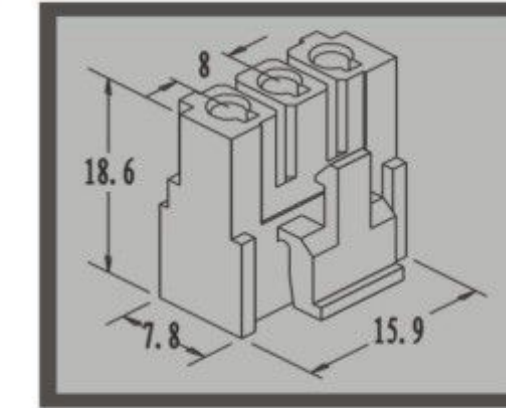

HAY800B-n

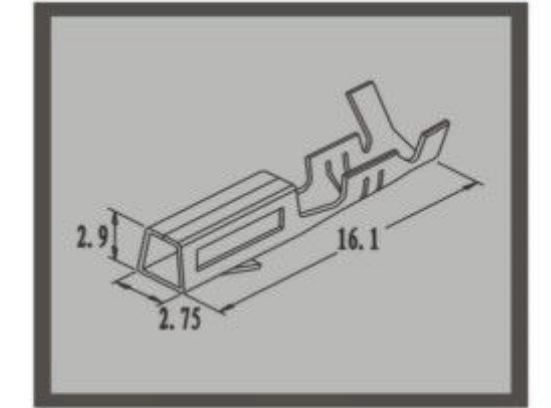

HAS800B-PT

HA1000-800A(TJC1)
主要技术特性: Main Specifications
间距 Pitch: 10mm
线数 Lines: 1-6
适合电线范围 Applicable wire range: AWG24#~18#
环境温度 Environment temperature: -25℃~+85℃
额定电压 Rate voltage: 300V AC, DC
额定电流 Rate current: 7.0A AC, DC
接触电阻 Contact resistance: ≤10mΩ
绝缘电阻 Insulation resistance: ≥1000mΩ
耐压 Voltage resisting: AC1500V.1min

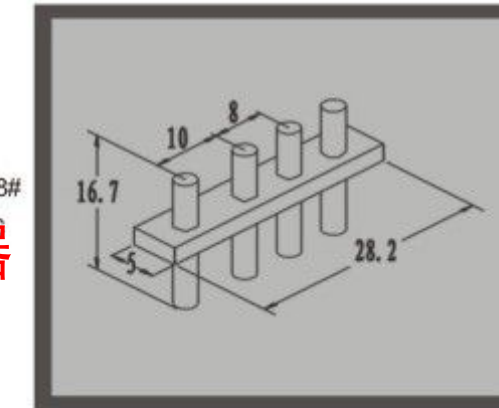

HAA1000-800A-n

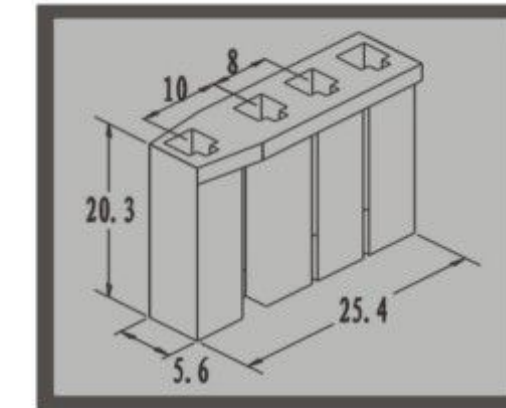

HAY1000-800A-n

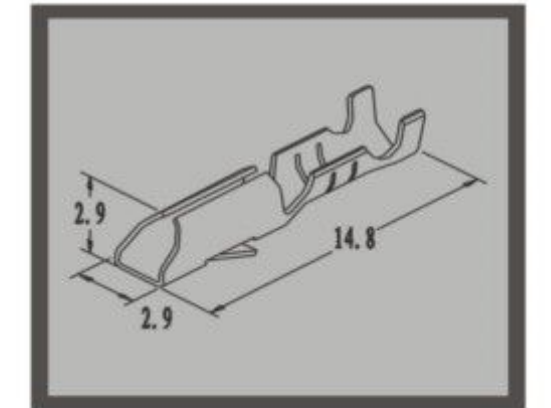

HAS1000-800A-PT

JPG 转 PDF 转换器 – 未注册版

如果您需要去掉这行字，请注册 JPG 转 PDF 转换器

连接器配件图

Connector Component

型号: BHD-RT
Part NO: BHD-RT
适用导线: AWG#24-20
Wire Range: AWG#24-20
表面处理: 镀锡
Finish: Tin-plated
材料: 磷青铜
Material: Phosphor Bronze

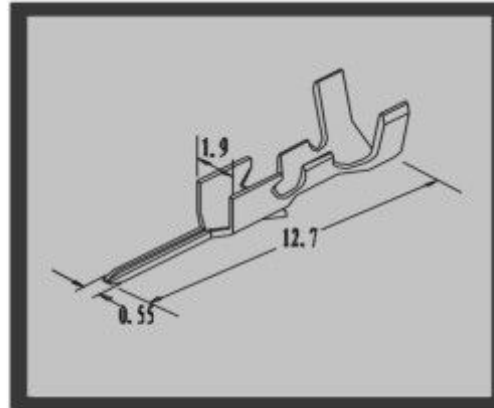

型号: BH-RT
Part NO: BHR
适用导线: AWG#20-16
Wire Range: AWG#20-16
表面处理: 镀锡
Finish: Tin-plated
材料: 磷青铜
Material: Phosphor Bronze

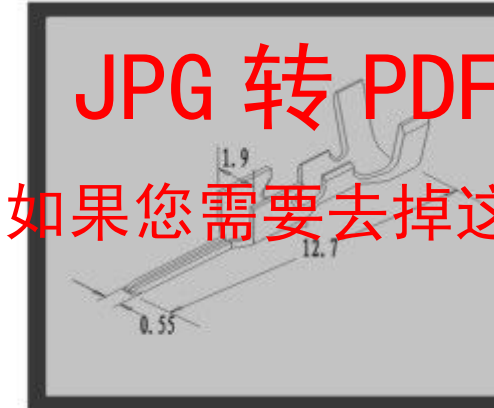

型号: BHD-PT
Part NO: BHD
适用导线: AWG#26-22
Wire Range: AWG#26-22
表面处理: 镀锡
Finish: Tin-plated
材料: 磷青铜
Material: Phosphor Bronze

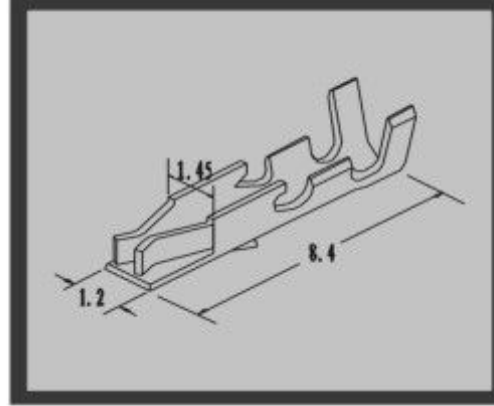

型号: BH-PT
Part NO: BH
适用导线: AWG#24-20
Wire Range: AWG#24-20
表面处理: 镀锡
Finish: Tin-plated
材料: 磷青铜
Material: Phosphor Bronze

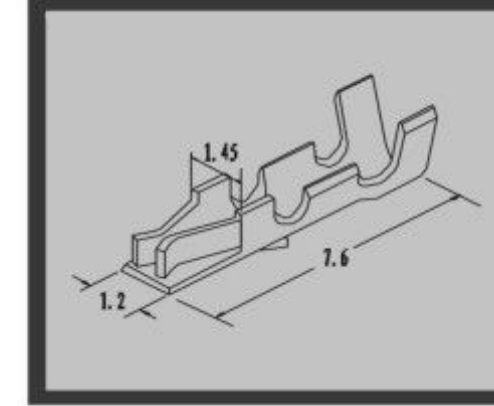

型号: Φ1.41(HA6043)
Part NO: Φ1.41
适用导线: AWG#26-22
Wire Range: AWG#26-22
表面处理: 镀锡
Finish: Tin-plated
材料: 黄铜(H62)
Material: Brass(H62)

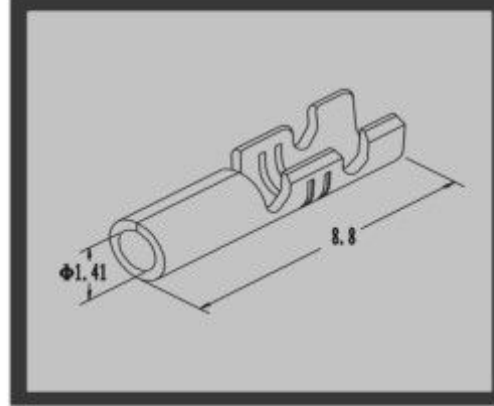

型号: 950406
Part NO: 950406
适用导线: AWG#24-20
Wire Range: AWG#24-20
表面处理: 镀锡
Finish: Tin-plated
材料: 黄铜(H62)
Material: Brass(H62)



型号: DJ211-Φ4(HA6047)
Part NO: ΦDJ211-Φ4
适用导线: AWG#22-18
Wire Range: AWG#22-18
表面处理: 镀锡
Finish: Tin-plated
材料: 黄铜(H62)
Material: Brass(H62)

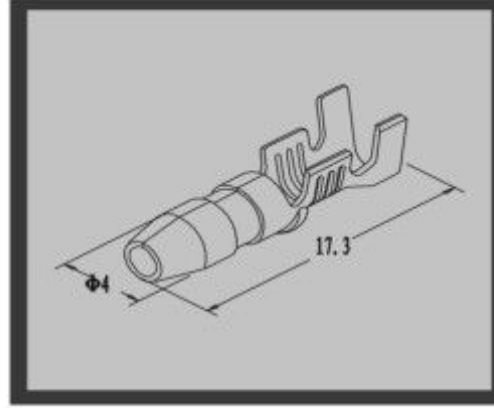

型号: DJ221-Φ4(HA6048)
Part NO: DJ221-Φ4
适用导线: AWG#22-18
Wire Range: AWG#22-18
表面处理: 镀锡
Finish: Tin-plated
材料: 黄铜(H62)
Material: Brass(H62)

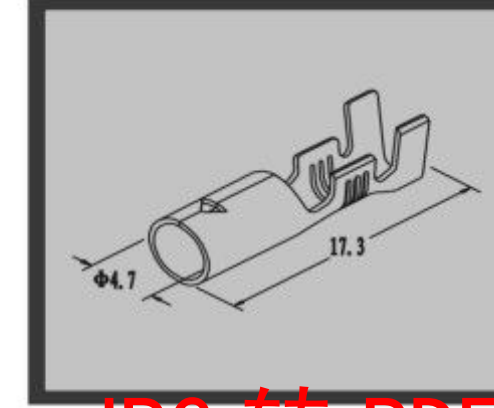

型号: Φ2电源内扣(HA6023)
Part NO: Φ2电源内扣
适用导线: AWG#22-18
Wire Range: AWG#22-18
表面处理: 镀锡
Finish: Tin-plated
材料: 磷青铜
Material: Phosphor Bronze

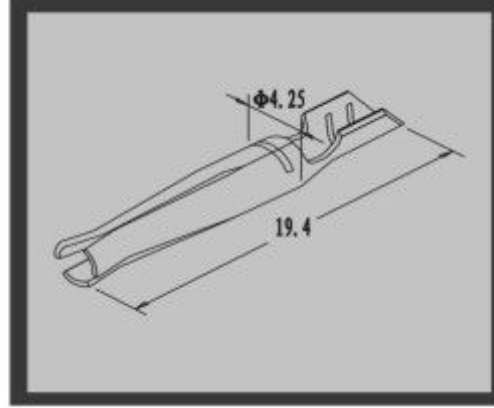

型号: 地环端子(HA6097)
Part NO: 地环端子
适用导线: AWG#24-20
Wire Range: AWG#24-20
表面处理: 镀锡
Finish: Tin-plated
材料: 黄铜(H62)
Material: Brass(H62)

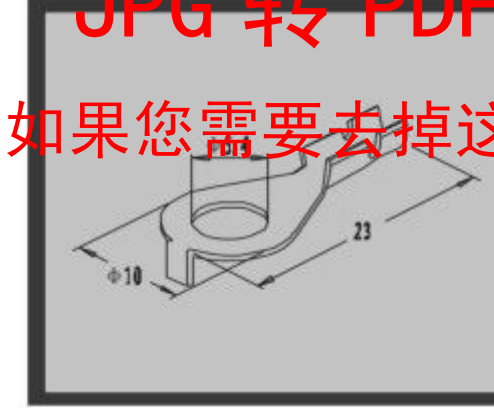

连接器配件图

Connector Component

型号: C8A(HA6005)
Part NO: C8A
表面处理: 镀锡
Finish: Tin-plated
材料: 磷青铜
Material: Phosphor Bronze

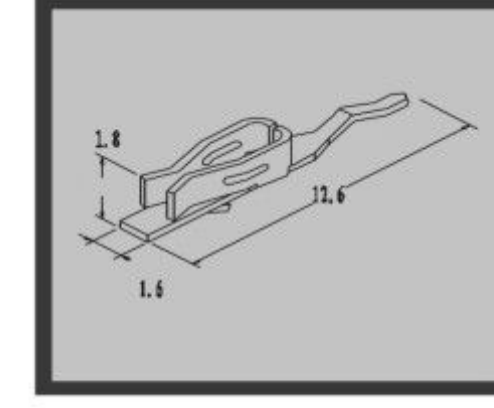

型号: C8B(HA6005)
Part No: C8B
表面处理: 镀锡
Finish: Tin-plated
材料: 磷青铜
Material: Phosphor Bronze

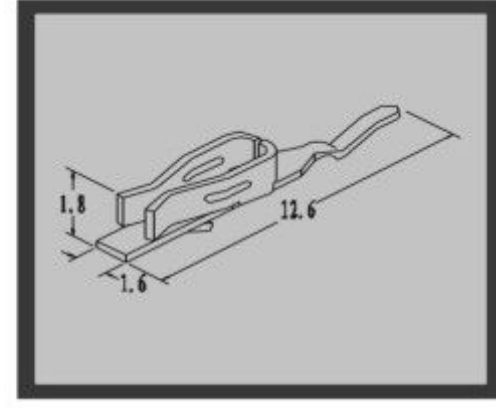

型号: JVC(HA6007)
Part NO: JVC
适用导线: AWG#28-22
Wire Range: AWG#28-22
表面处理: 镀锡
Finish: Tin-plated
材料: 磷青铜
Material: Phosphor Bronze

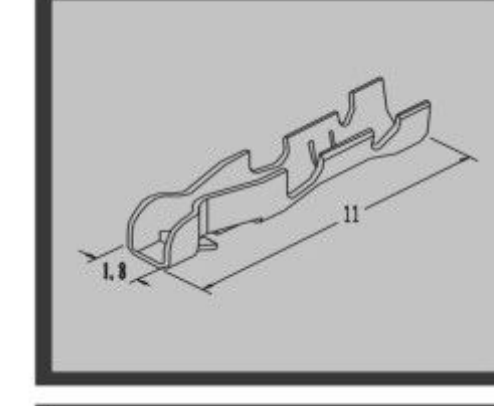

型号: MXJ(HA6010)
Part No: MXJ
适用导线: AWG#28-22
Wire Range: AWG#28-22
表面处理: 镀锡
Finish: Tin-plated
材料: 磷青铜
Material: Phosphor Bronze

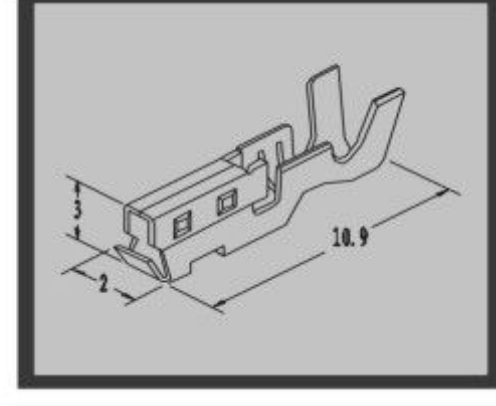

型号: SA(HA6008)
Part NO: SA
适用导线: AWG#24-20
Wire Range: AWG#24-20
表面处理: 镀锡
Finish: Tin-plated
材料: 磷青铜
Material: Phosphor Bronze

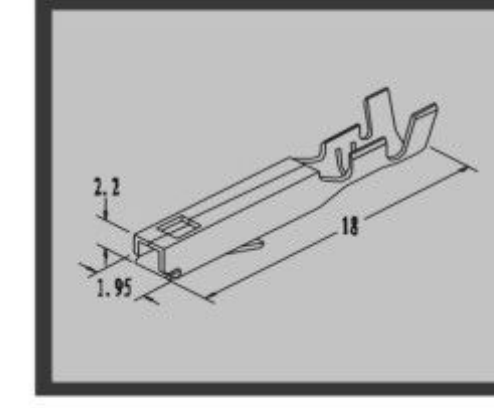

型号: 50364(HA6011)
Part No: 50364
适用导线: AWG#24-20
Wire Range: AWG#24-20
表面处理: 镀锡
Finish: Tin-plated
材料: 磷青铜
Material: Phosphor Bronze

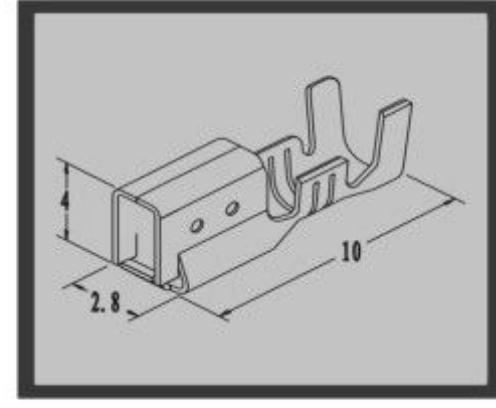

型号: YXJ(HA6030)
Part NO: YXJ
适用导线: AWG#24-20
Wire Range: AWG#24-20
表面处理: 镀锡
Finish: Tin-plated
材料: 磷青铜
Material: Phosphor Bronze

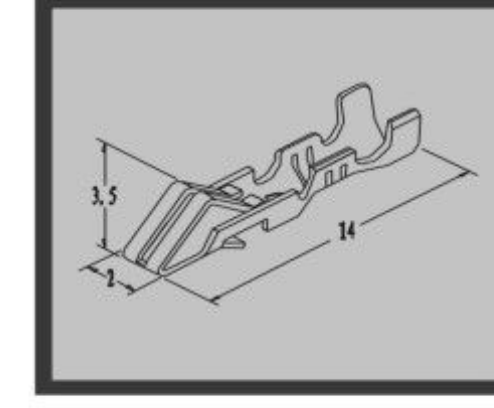

型号: BGX(HA6032)
Part No: BGX
适用导线: AWG#24-20
Wire Range: AWG#24-20
表面处理: 镀锡
Finish: Tin-plated
材料: 黄铜(H62)
Material: Brass(H62)

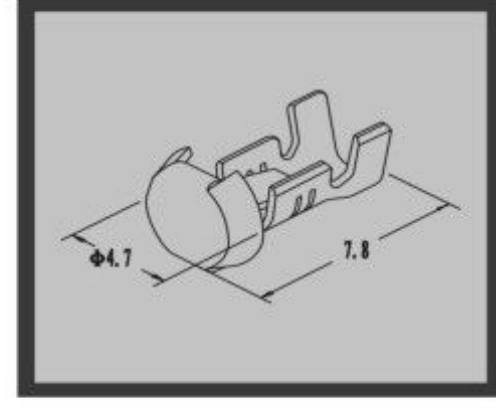

型号: 3.96B
Part NO: 3.96B
表面处理: 镀锡
Finish: Tin-plated
材料: 磷青铜
Material: Phosphor Bronze

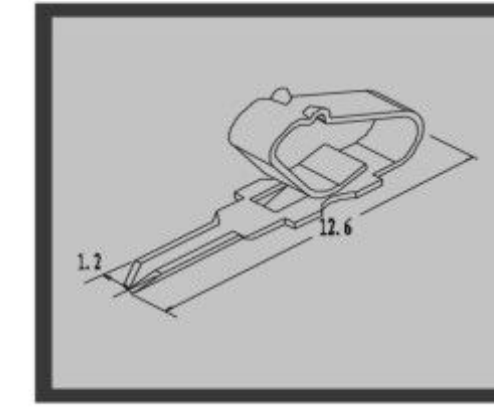

型号: DJ622-2(HA6084)
Part NO: DJ622-2
适用导线: AWG#24-20
Wire Range: AWG#24-20
表面处理: 镀锡
Finish: Tin-plated
材料: 磷青铜
Material: Phosphor Bronze

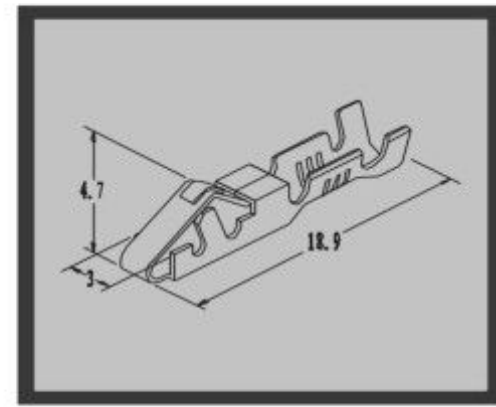

JPG 转 PDF 转换器 - 未注册版

如果您需要去掉这行字, 请注册 JPG 转 PDF 转换器

连接器配件图

Connector Component

型号: DJ611-2.3A(HA6073)
Part NO:DJ611-2.3A
适用导线: AWG#24-20
Wire Range:AWG#24-20
表面处理: 镀锡
Finish:Tin-plated
材料: 黄铜(H62)
Material:Brass(H62)
厚度: 0.6mm
Thickness:0.6mm

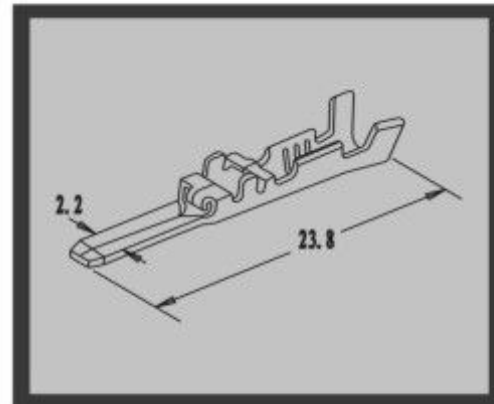

型号: DJ611-2.3C
Part NO:DJ611-2.3C
适用导线: AWG#24-20
Wire Range:AWG#24-20
表面处理: 镀锡
Finish:Tin-plated
材料: 黄铜(H62)
Material:Brass(H62)
厚度: 0.6mm
Thickness:0.6mm

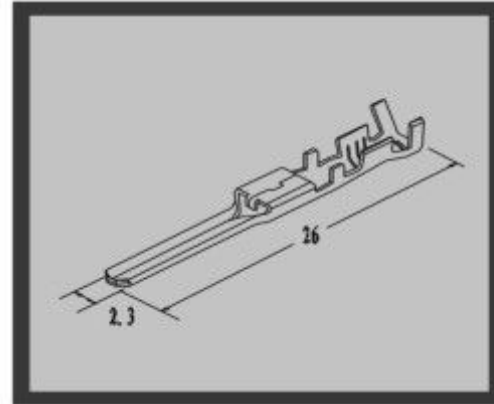

型号: DJ611-2.8(HA6076)
Part NO:DJ611-2.8
适用导线: AWG#24-20
Wire Range:AWG#24-20
表面处理: 镀锡
Finish:Tin-plated
材料: 黄铜(H62)
Material:Brass(H62)
厚度: 0.6mm
Thickness:0.6mm

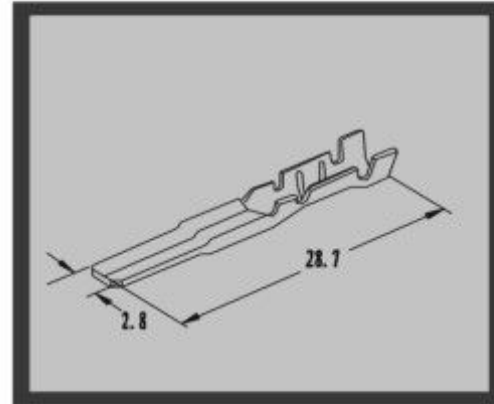

型号: DJ611-2.8(HA6071)
Part NO:DJ611-2.8
适用导线: AWG#24-20
Wire Range:AWG#24-20
表面处理: 镀锡
Finish:Tin-plated
材料: 黄铜(H62)
Material:Brass(H62)
厚度: 0.5mm
Thickness:0.5mm

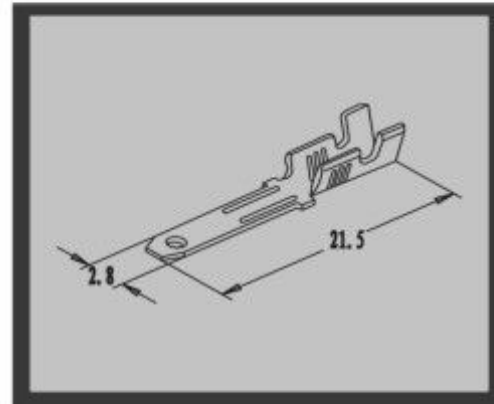

型号: DJ611-2.3B(HA6073)
Part NO:DJ611-2.3B
适用导线: AWG#24-20
Wire Range:AWG#24-20
表面处理: 镀锡
Finish:Tin-plated
材料: 黄铜(H62)
Material:Brass(H62)
厚度: 0.6mm
Thickness:0.6mm

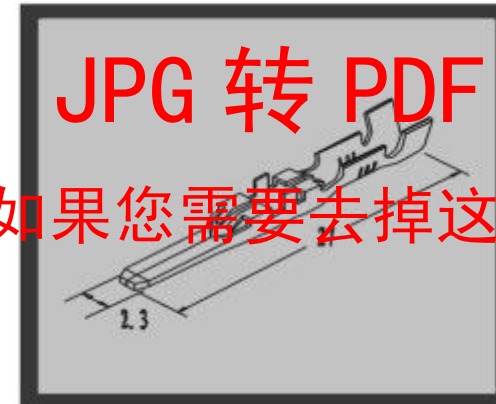

型号: DJ611-2.7(HA6075)
Part NO:DJ611-2.7
适用导线: AWG#22-18
Wire Range:AWG#22-18
表面处理: 镀锡
Finish:Tin-plated
材料: 黄铜(H62)
Material:Brass(H62)
厚度: 0.6mm
Thickness:0.6mm

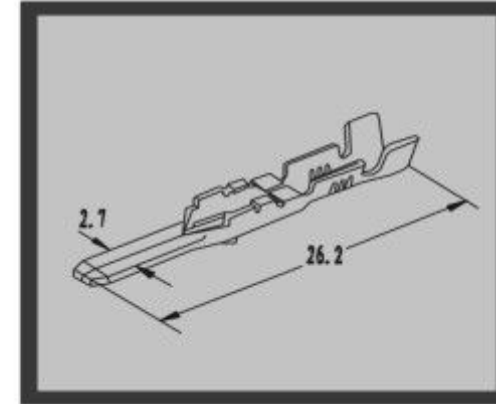

型号: DJ611-2.8L(HA6072)
Part NO:DJ611-2.8L
适用导线: AWG#24-18
Wire Range:AWG#24-18
表面处理: 镀锡
Finish:Tin-plated
材料: 黄铜(H62)
Material:Brass(H62)
厚度: 0.5mm
Thickness:0.5mm

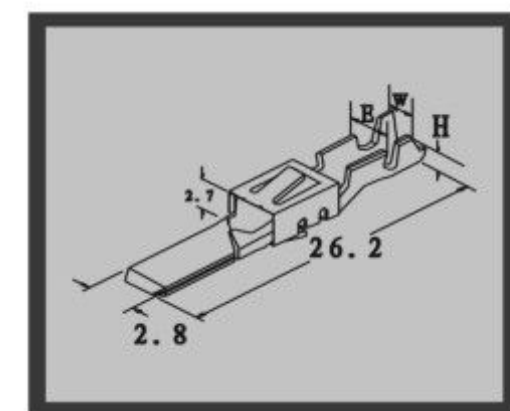

类号 NO Part	适用导线 Wire Range	尺寸 Size(mm)			厚度 Thickness	表面处理 Finish	材料 Material
		W	E	H			
632880A	AWG#24-22	2.8	21.7	2.7	0.4	镀锡 Tin-plated	磷青铜 Phosphor Bronze
632880B	AWG#20-18	2.8	26.2	2.7			
632880C	AWG#18-16	2.8	26	2.7			

连接器配件图

Connector Component

型号: 喇叭插片(HA6045)
Part NO:喇叭插片
表面处理: 镀锡
Finish:Tin-plated
材料: 黄铜(H62)
Material:Brass(H62)
厚度: 0.5mm
Thickness:0.5mm

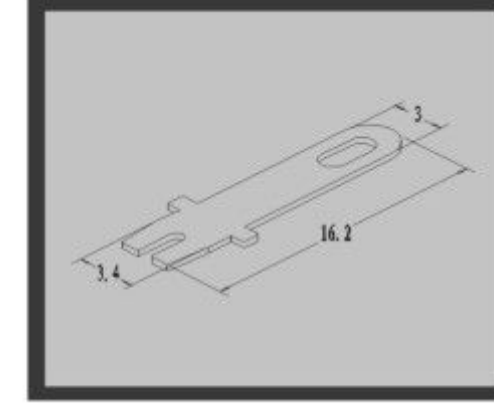

型号: 187RB(HA6068)
Part NO:187RB
表面处理: 镀锡
Finish:Tin-plated
材料: 黄铜(H62)
Material:Brass(H62)
厚度: 0.5mm
Thickness:0.5mm

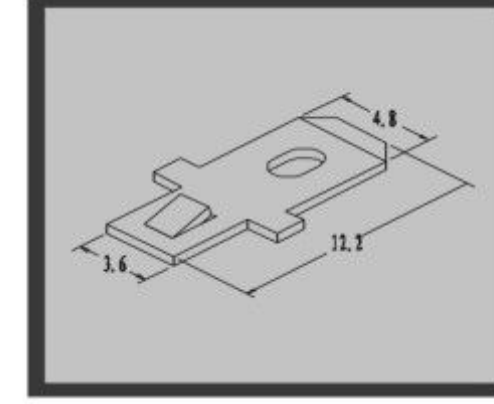

型号: 250RB(HA6070)
Part NO:250RB
适用导线: AWG#24-20
Wire Range:AWG#24-20
表面处理: 镀锡
Finish:Tin-plated
材料: 黄铜(H62)
Material:Brass(H62)
厚度: 0.8mm
Thickness:0.8mm

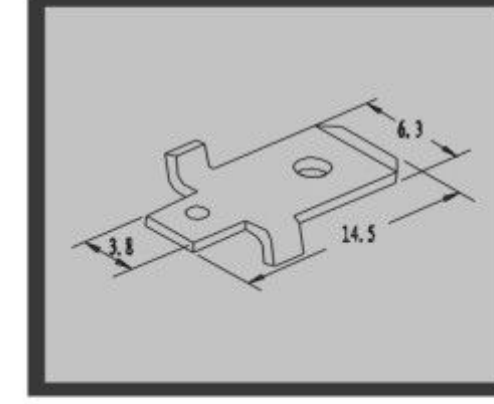

型号: DJ621-1.2(HA6078)
Part NO:DJ621-1.2
适用导线: AWG#24-20
Wire Range:AWG#24-20
表面处理: 镀锡
Finish:Tin-plated
材料: 磷青铜
Material:Phosphor Bronze

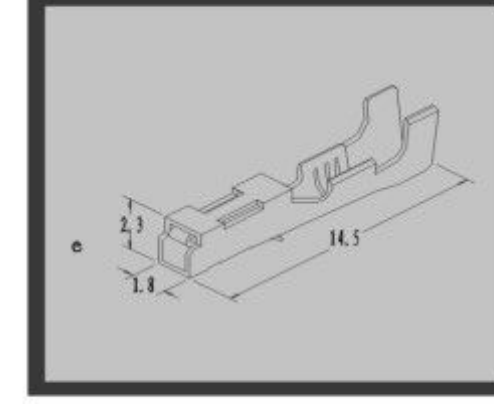

型号: DJ621-2.3B(HA6080)
Part NO:DJ621-2.3B
适用导线: AWG#24-20
Wire Range:AWG#24-20
表面处理: 镀锡
Finish:Tin-plated
材料: 黄铜(H62)
Material:Brass(H62)

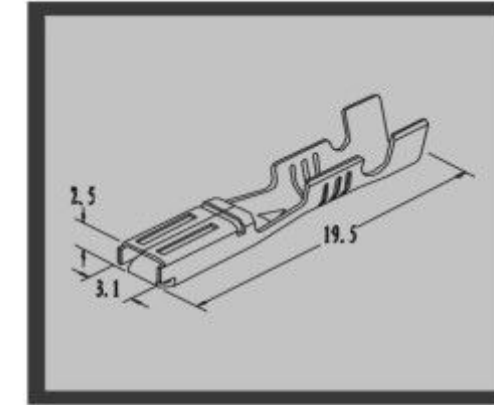

型号: 187RA(HA6067)
Part NO:187RA
表面处理: 镀锡
Finish:Tin-plated
材料: 黄铜(H62)
Material:Brass(H62)
厚度: 0.5mm
Thickness:0.5mm

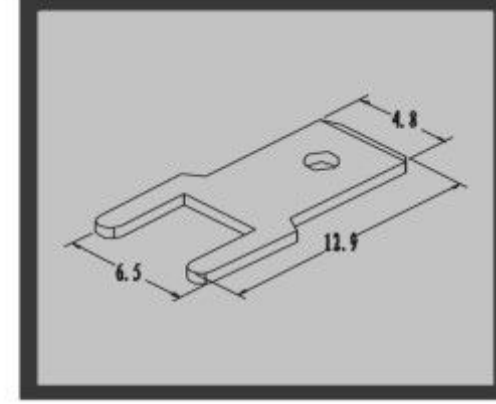

型号: 250RA(HA6069)
Part NO:250RA
表面处理: 镀锡
Finish:Tin-plated
材料: 黄铜(H62)
Material:Brass(H62)
厚度: 0.8mm
Thickness:0.8mm

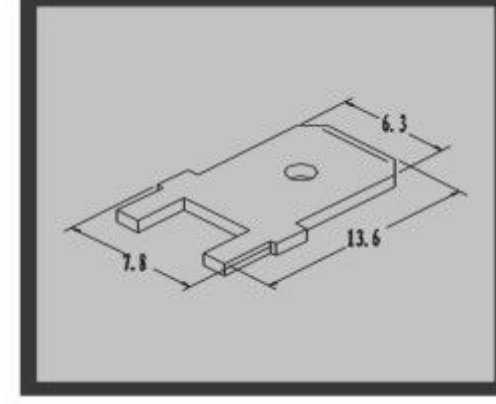

型号: 250RL(HA6077)
Part NO:250RL
适用导线: AWG#22-18
Wire Range:AWG#22-18
表面处理: 镀锡
Finish:Tin-plated
材料: 黄铜(H62)
Material:Brass(H62)
厚度: 0.8mm
Thickness:0.8mm

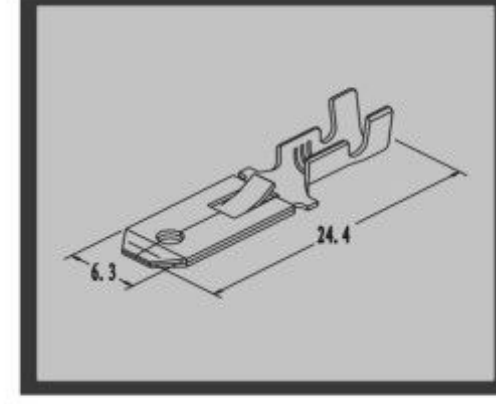

型号: DJ621-2.3A(HA6079)
Part NO:DJ621-2.3A
适用导线: AWG#24-20
Wire Range:AWG#24-20
表面处理: 镀锡
Finish:Tin-plated
材料: 黄铜(H62)
Material:Brass(H62)

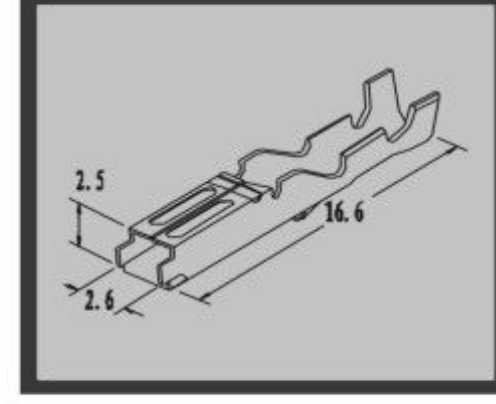

型号: DJ621-G2.06(HA6081)
Part NO:DJ621-G2.06
适用导线: AWG#24-20
Wire Range:AWG#24-20
表面处理: 镀锡
Finish:Tin-plated
材料: 黄铜(H62)
Material:Brass(H62)

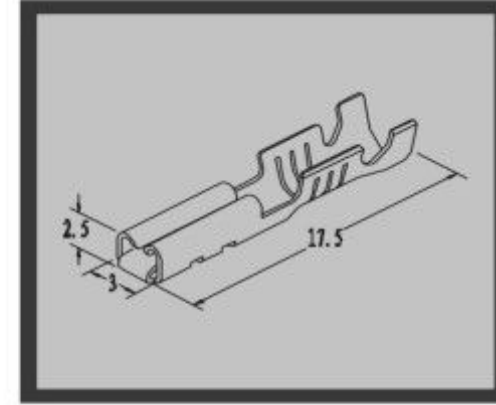

JPG 转 PDF 转换器 – 未注册版

如果您需要去掉这行字，请注册 JPG 转 PDF 转换器

连接器配件图

Connector Component

型号: 喇叭插(HA6046)
Part NO:喇叭插
适用导线: AWG#24-20
Wire Range:AWG#24-20
表面处理: 镀锡
Finish:Tin-plated
材料: 黄铜(H62)
Material:Brass(H62)

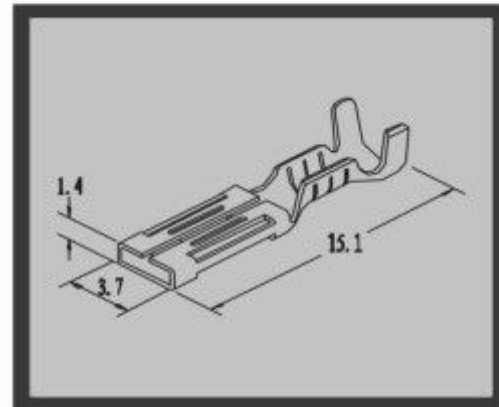

型号: EX(HA6109)
Part NO:EX
适用导线: AWG#24-20
Wire Range:AWG#24-20
表面处理: 镀锡
Finish:Tin-plated
材料: 磷青铜
Material:Phosphor Bronze

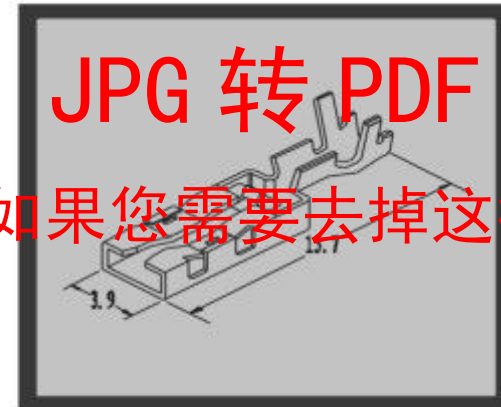

型号: DJ621-2.2(HA6082)
Part NO:DJ621-2.2
适用导线: AWG#22-18
Wire Range:AWG#22-18
表面处理: 镀锡
Finish:Tin-plated
材料: 磷青铜
Material:Phosphor Bronze

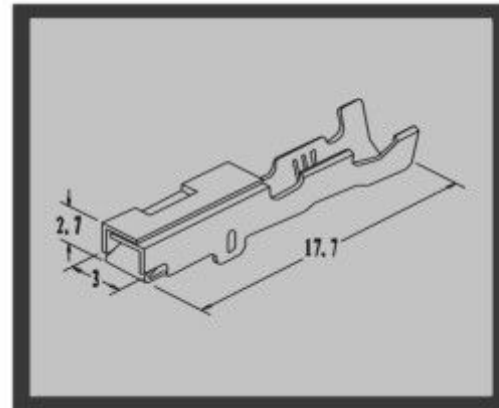

型号: DJ621-F3.0(HA6087)
Part NO:DJ621-F3.0
适用导线: AWG#24-20
Wire Range:AWG#24-20
表面处理: 镀锡
Finish:Tin-plated
材料: 黄铜(H62)
Material:Brass(H62)

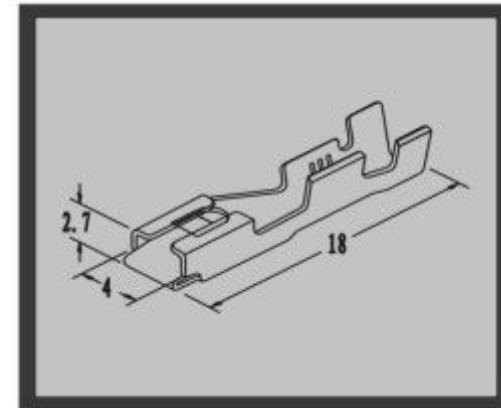

型号: DJ633-0.5
Part NO:DJ633-0.5
适用导线: AWG#20-16
Wire Range:AWG#20-16
表面处理: 镀锡
Finish:Tin-plated
材料: 磷青铜
Material:Phosphor Bronze

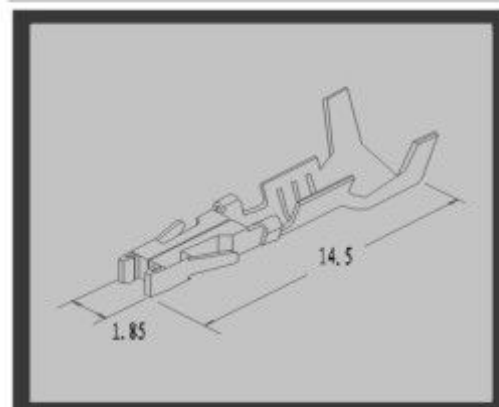

型号: DJ633-1.2
Part NO:DJ633-1.2
适用导线: AWG#22-18
Wire Range:AWG#22-18
表面处理: 镀锡
Finish:Tin-plated
材料: 磷青铜
Material:Phosphor Bronze

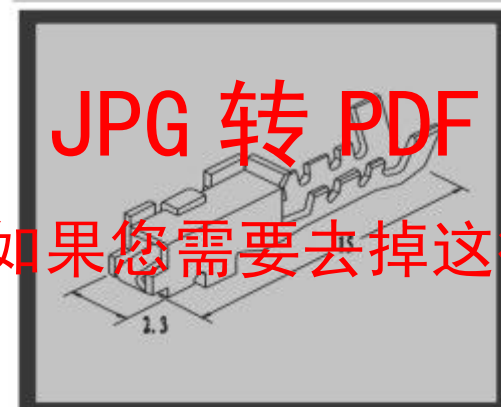

型号: DJ633-1.6
Part NO:DJ633-1.6
适用导线: AWG#22-16
Wire Range:AWG#22-16
表面处理: 镀锡
Finish:Tin-plated
材料: 磷青铜
Material:Phosphor Bronze

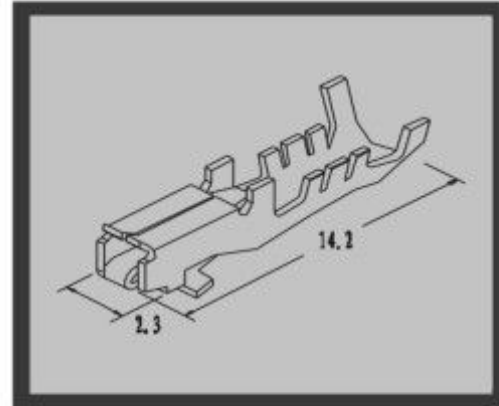

型号: DJ633-2.8
Part NO:DJ633-2.8
适用导线: AWG#22-16
Wire Range:AWG#22-16
表面处理: 镀锡
Finish:Tin-plated
材料: 磷青铜
Material:Phosphor Bronze

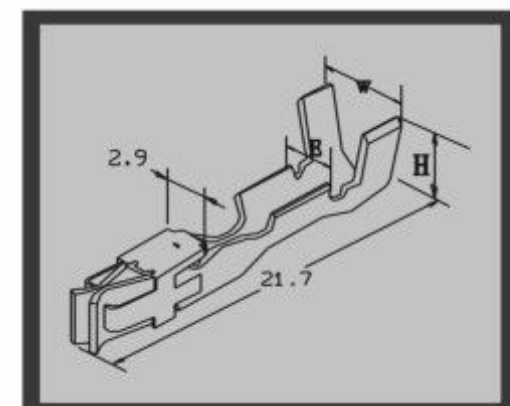
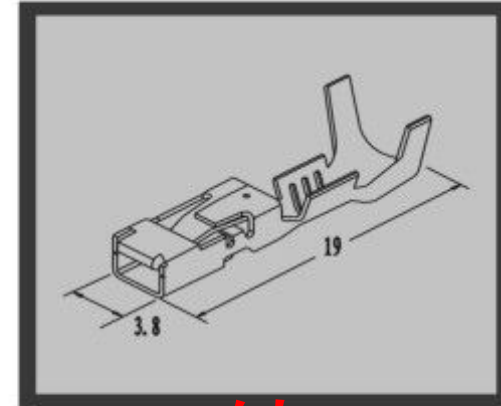

类号 NO Part	适用导线 Wire Range	尺寸 Size(mm)			表面处理 Finish	材料 Material
		W	E	H		
DJ623-E3.5A	AWG#24-22	2.8	21.7	2.7	镀锡 Tin-plated	磷青铜 Phosphor Bronze
DJ623-E3.5B	AWG#20-18	2.8	26.2	2.7		
DJ623-E3.5C	AWG#18-16	2.8	26	2.7		

连接器配件图

Connector Component

型号: DJ621-3.0C
Part NO:DJ621-3.0C
适用导线: AWG#24-20
Wire Range:AWG#24-20
表面处理: 镀锡
Finish:Tin-plated
材料: 磷青铜
Material:Phosphor Bronze

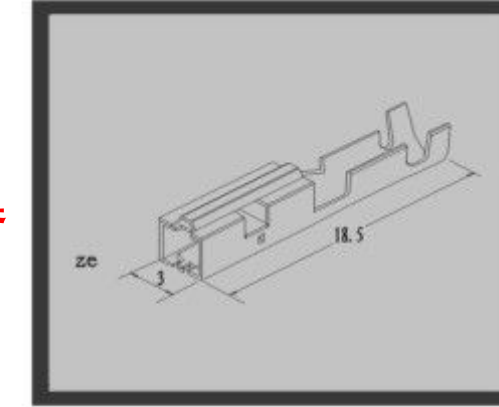

型号: DJ621-4.8D(HA6085)
Part NO:DJ621-4.8D
适用导线: AWG#20-16
Wire Range:AWG#20-16
表面处理: 镀锡
Finish:Tin-plated
材料: 黄铜(H62)
Material:Brass(H62)

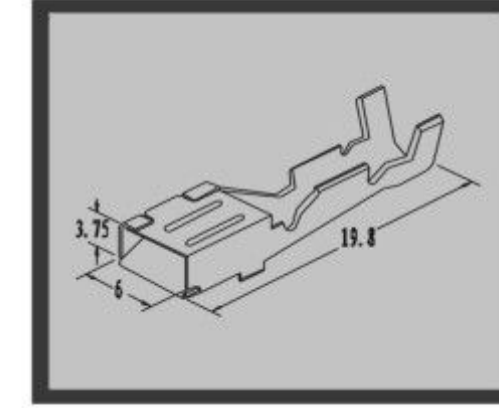

型号: 110HL(HA6051)
Part NO:110HL
适用导线: AWG#24-20
Wire Range:AWG#24-20
表面处理: 镀锡
Finish:Tin-plated
材料: 黄铜(H62)
Material:Brass(H62)

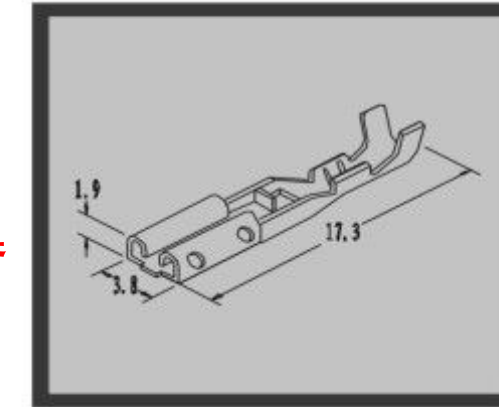

型号: 187F(HA6055)
Part NO:187F
适用导线: AWG#20-14
Wire Range:AWG#20-14
表面处理: 镀锡
Finish:Tin-plated
材料: 黄铜(H62)
Material:Brass(H62)

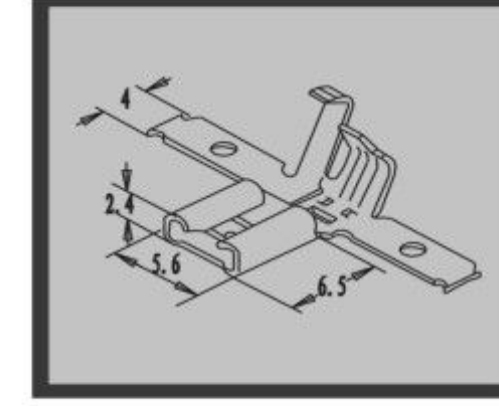

型号: 205D(HA6056)
Part NO:205D
适用导线: AWG#22-18
Wire Range:AWG#22-18
表面处理: 镀锡
Finish:Tin-plated
材料: 黄铜(H62)
Material:Brass(H62)

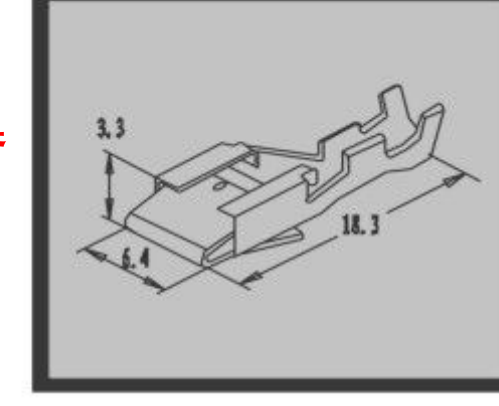

型号: DJ623-2.2B
Part NO:DJ623-2.2B
适用导线: AWG#22-18
Wire Range:AWG#22-18
表面处理: 镀锡
Finish:Tin-plated
材料: 黄铜(H62)
Material:Brass(H62)

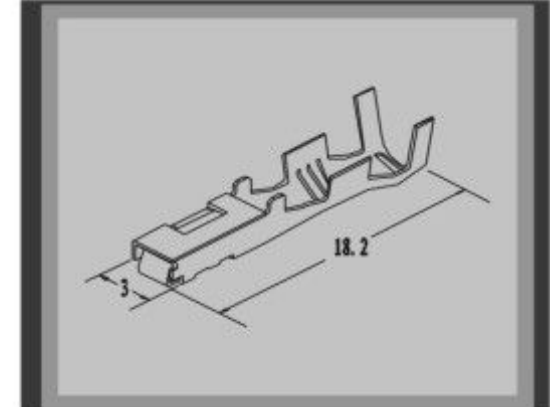

型号: DJ627-7.8B(HA6086)
Part NO:DJ627-7.8B
适用导线: AWG#18-14
Wire Range:AWG#18-14
表面处理: 镀锡
Finish:Tin-plated
材料: 黄铜(H62)
Material:Brass(H62)

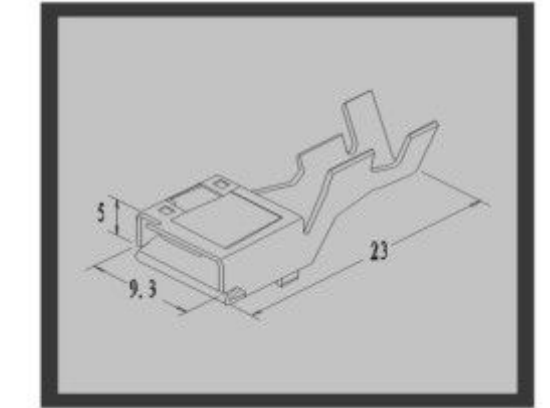

型号: 187Z(HA6053)
Part NO:187Z
适用导线: AWG#22-18
Wire Range:AWG#22-18
表面处理: 镀锡
Finish:Tin-plated
材料: 黄铜(H62)
Material:Brass(H62)

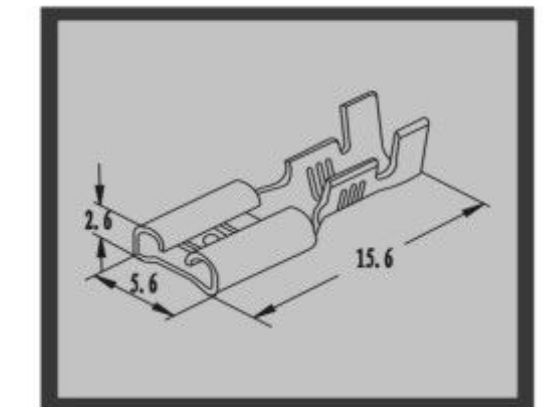

型号: 205HL(HA6051)
Part NO:205HL
适用导线: AWG#24-20
Wire Range:AWG#24-20
表面处理: 镀锡
Finish:Tin-plated
材料: 黄铜(H62)
Material:Brass(H62)

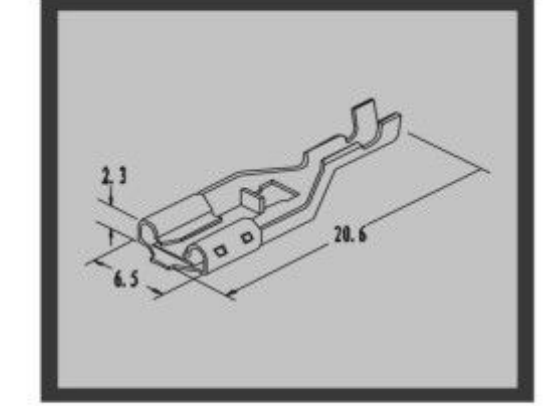

型号: 205F(HA6054)
Part NO:205F
适用导线: AWG#22-18
Wire Range:AWG#22-18
表面处理: 镀锡
Finish:Tin-plated
材料: 黄铜(H62)
Material:Brass(H62)

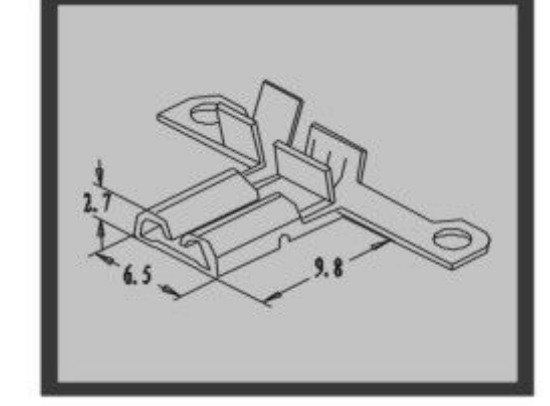

JPG 转 PDF 转换器 – 未注册版

如果您需要去掉这行字，请注册 JPG 转 PDF 转换器

连接器配件图

Connector Component

型号: 250HA(HA6057)
Part NO:250HA
适用导线: AWG#22-18
Wire Range:AWG#22-18
表面处理: 镀锡
Finish:Tin-plated
材料: 黄铜(H62)
Material:Brass(H62)

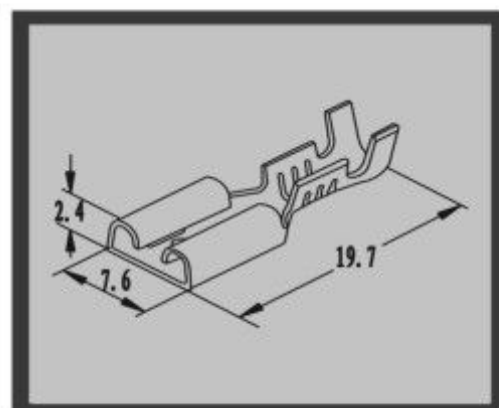

型号: 250HB(HA6058)
Part NO:250HB
适用导线: AWG#22-18
Wire Range:AWG#22-18
表面处理: 镀锡
Finish:Tin-plated
材料: 黄铜(H62)
Material:Brass(H62)

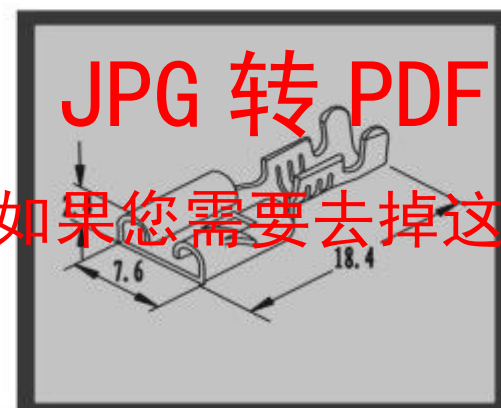

型号: 250Z(HA6061)
Part NO:250Z
适用导线: AWG#22-18
Wire Range:AWG#22-18
表面处理: 镀锡
Finish:Tin-plated
材料: 黄铜(H62)
Material:Brass(H62)

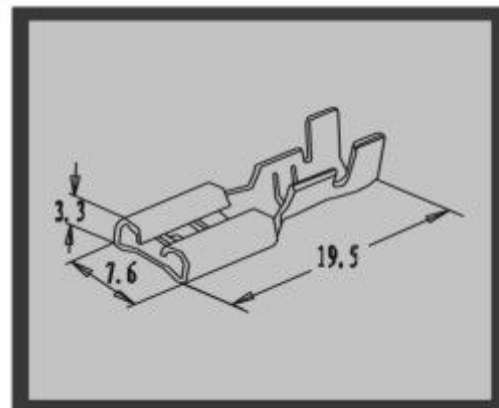

型号: 250ZL(HA6060)
Part NO:250ZL
适用导线: AWG#22-18
Wire Range:AWG#22-18
表面处理: 镀锡
Finish:Tin-plated
材料: 黄铜(H62)
Material:Brass(H62)

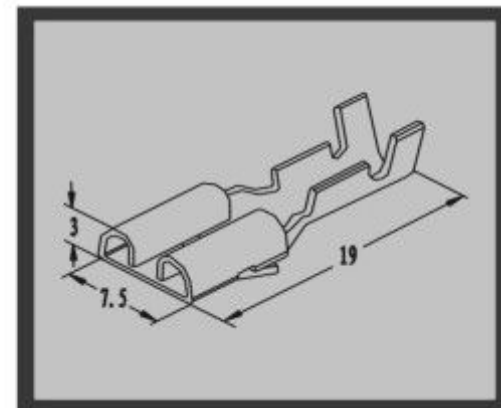

型号: 250D(HA6059)
Part NO:250D
适用导线: AWG#22-18
Wire Range:AWG#22-18
表面处理: 镀锡
Finish:Tin-plated
材料: 黄铜(H62)
Material:Brass(H62)

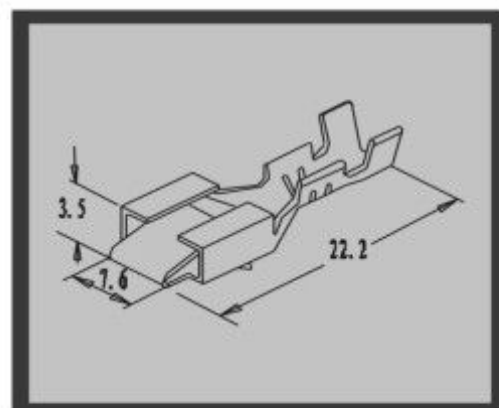

型号: 250F(HA6063)
Part NO:250F
适用导线: AWG#18-12
Wire Range:AWG#18-12
表面处理: 镀锡
Finish:Tin-plated
材料: 黄铜(H62)
Material:Brass(H62)



型号: 250FL(HA6064)
Part NO:250FL
适用导线: AWG#18-12
Wire Range:AWG#18-12
表面处理: 镀锡
Finish:Tin-plated
材料: 黄铜(H62)
Material:Brass(H62)

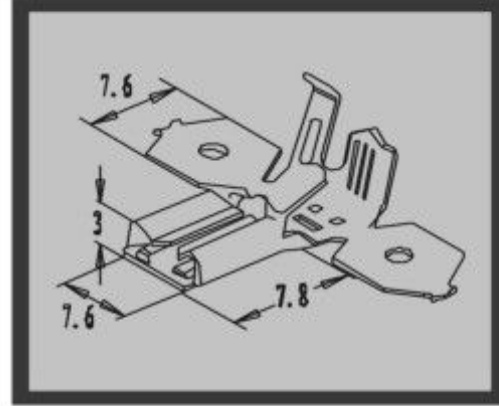

型号: 250S(HA6062)
Part NO:250S
适用导线: AWG#18-14
Wire Range:AWG#18-14
表面处理: 镀锡
Finish:Tin-plated
材料: 黄铜(H62)
Material:Brass(H62)

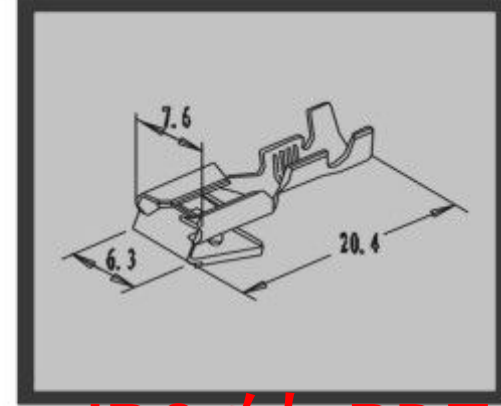

型号: 250HL
Part NO:250HL
适用导线: AWG#22-18
Wire Range:AWG#22-18
表面处理: 镀锡
Finish:Tin-plated
材料: 磷青铜
Material:Phosphor Bronze

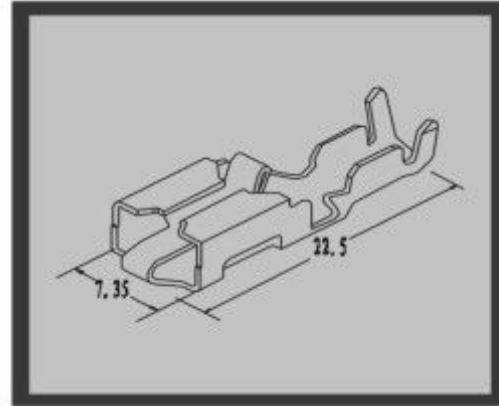

型号: 250HFL
Part NO:250HFL
适用导线: AWG#22-16
Wire Range:AWG#22-16
表面处理: 镀锡
Finish:Tin-plated
材料: 磷青铜
Material:Phosphor Bronze

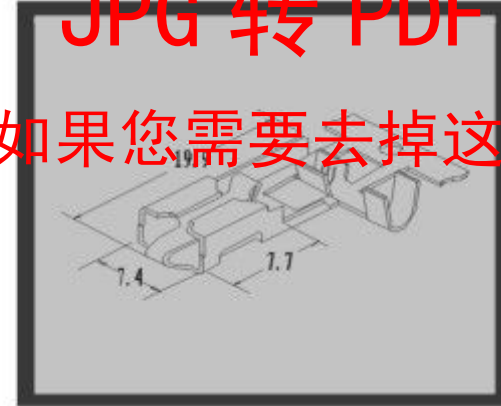

连接器配件图

Connector Component

型号: DLS(HA6029)
Part NO:DLS
适用导线: AWG#22-18
Wire Range:AWG#22-18
表面处理: 镀锡
Finish:Tin-plated
材料: 磷青铜
Material:Phosphor Bronze

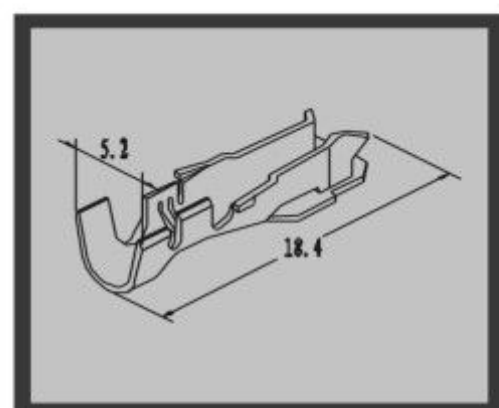

型号: BX2141(HA6066)
Part NO:BX2141
适用导线: AWG#22-16
Wire Range:AWG#22-16
表面处理: 镀锡
Finish:Tin-plated
材料: 黄铜(H62)
Material:Brass(H62)

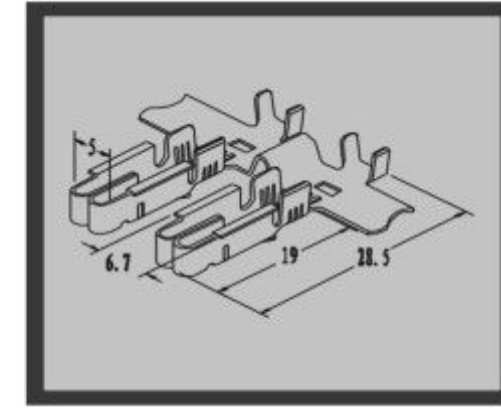

型号: TU1A
Part NO:TU1A
表面处理: 镀锡
Finish:Tin-plated
材料: 磷青铜
Material:Phosphor Bronze
厚度: 0.8mm
Thickness:0.8mm

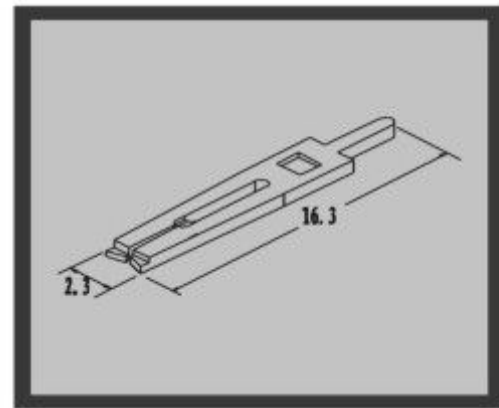

型号: TU1B
Part NO:TU1B
表面处理: 镀锡
Finish:Tin-plated
材料: 磷青铜
Material:Phosphor Bronze
厚度: 0.8mm
Thickness:0.8mm

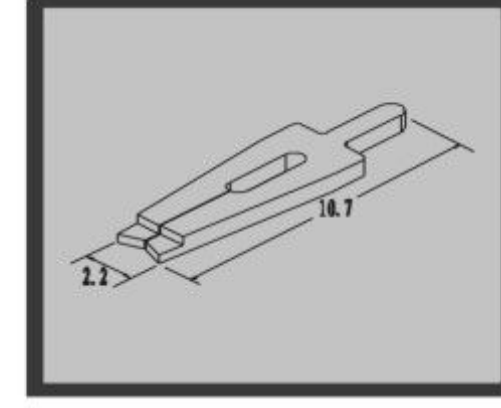

型号: TU1C
Part NO:TU1C
表面处理: 镀锡
Finish:Tin-plated
材料: 磷青铜
Material:Phosphor Bronze
厚度: 0.5mm
Thickness:0.5mm

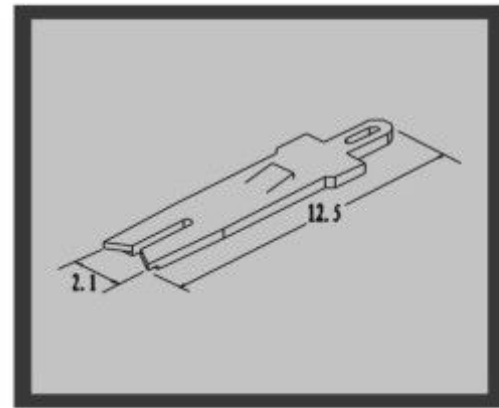

型号: TU1D
Part NO:TU1D
表面处理: 镀锡
Finish:Tin-plated
材料: 磷青铜
Material:Phosphor Bronze
厚度: 0.8mm
Thickness:0.8mm

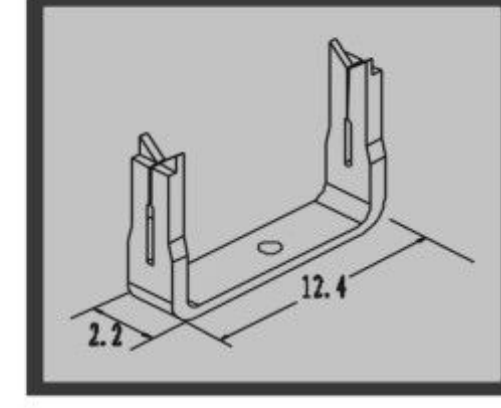

型号: 9823
Part NO:9823
表面处理: 镀锡
Finish:Tin-plated
材料: 磷青铜
Material:Phosphor Bronze
厚度: 0.8mm
Thickness:0.8mm

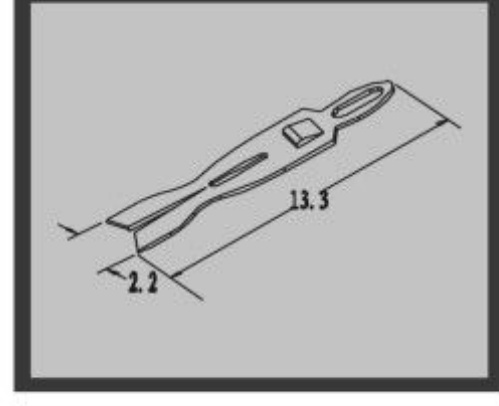

型号: SOM3.5A(HA6026)
Part NO:SOM3.5A
适用导线: AWG#22-18
Wire Range:AWG#22-18
表面处理: 镀锡
Finish:Tin-plated
材料: 黄铜(H62)
Material:Brass(H62)

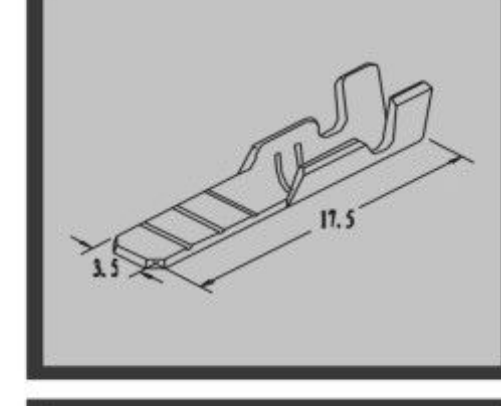

型号: SOM3.5B(HA6027)
Part NO:SOM3.5B
适用导线: AWG#22-18
Wire Range:AWG#22-18
表面处理: 镀锡
Finish:Tin-plated
材料: 黄铜(H62)
Material:Brass(H62)

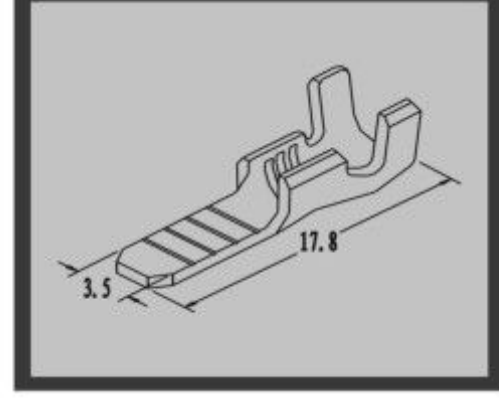

型号: SOM4(HA6028)
Part NO:SOM4
适用导线: AWG#22-18
Wire Range:AWG#22-18
表面处理: 镀锡
Finish:Tin-plated
材料: 黄铜(H62)
Material:Brass(H62)

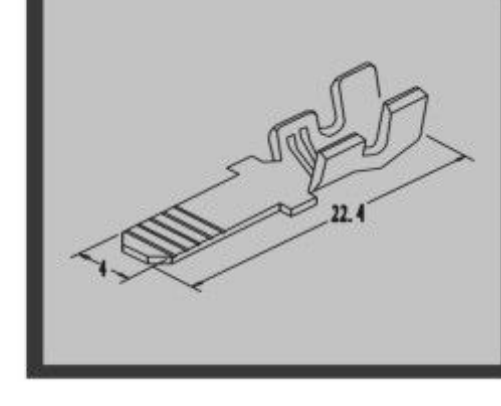

JPG 转 PDF 转换器 – 未注册版

如果您需要去掉这行字，请注册 JPG 转 PDF 转换器

连接器配件图

Connector Component

型号: SIN0.9
Part NO: SIN0.9
适用导线: AWG#26-20
Wire Range: AWG#26-20
表面处理: 镀锡
Finish: Tin-plated
材料: 磷青铜
Material: Phosphor Bronze

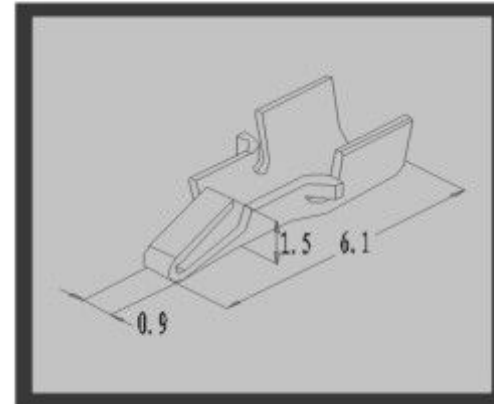

型号: SIN1.5(HA6012)
Part NO: SIN1.5
适用导线: AWG#26-20
Wire Range: AWG#26-20
表面处理: 镀锡
Finish: Tin-plated
材料: 磷青铜
Material: Phosphor Bronze

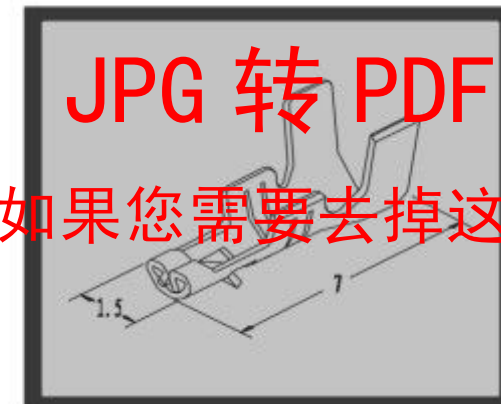

型号: SIN1.8(HA6013)
Part NO: SIN1.8
适用导线: AWG#24-18
Wire Range: AWG#24-18
表面处理: 镀锡
Finish: Tin-plated
材料: 磷青铜
Material: Phosphor Bronze

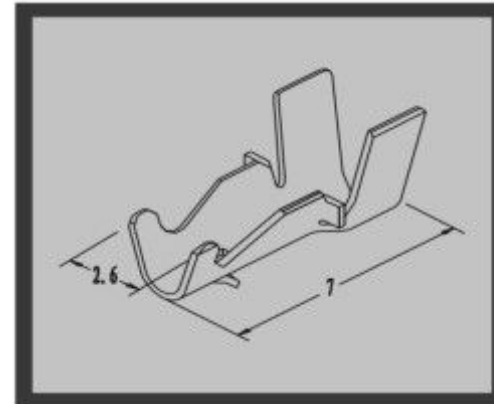

型号: SIN2.6S(HA6019)
Part NO: SIN2.6S
适用导线: AWG#24-20
Wire Range: AWG#24-20
表面处理: 镀锡
Finish: Tin-plated
材料: 磷青铜
Material: Phosphor Bronze

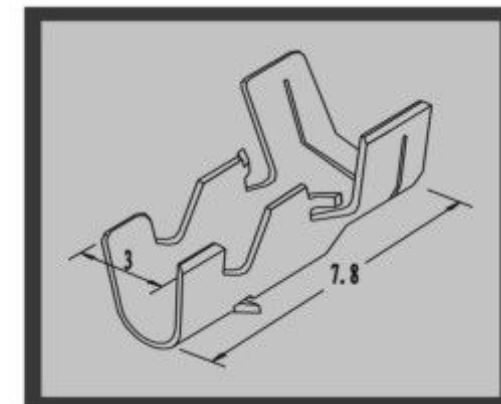

型号: SIN2.6(HA6020)
Part NO: SIN2.6
适用导线: AWG#24-18
Wire Range: AWG#24-18
表面处理: 镀锡
Finish: Tin-plated
材料: 磷青铜
Material: Phosphor Bronze

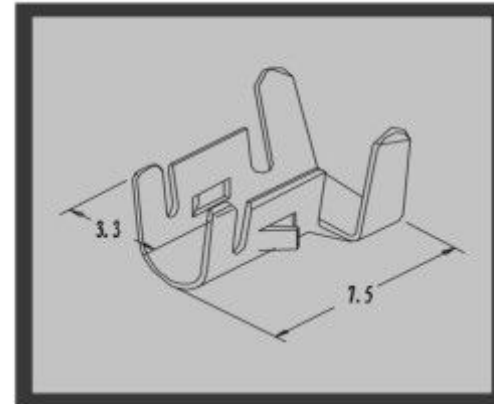

型号: SIN2.2(HA6018)
Part NO: SIN2.2
适用导线: AWG#24-20
Wire Range: AWG#24-20
表面处理: 镀锡
Finish: Tin-plated
材料: 磷青铜
Material: Phosphor Bronze

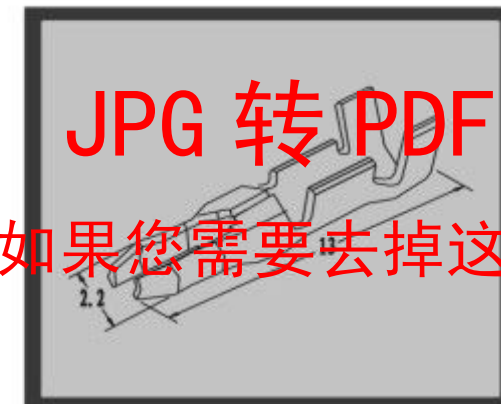

型号: SCP1.8-4.2(HA6020)
Part NO: SCP1.8-4.2
适用导线: AWG#24-18
Wire Range: AWG#24-18
表面处理: 镀锡
Finish: Tin-plated
材料: 磷青铜
Material: Phosphor Bronze

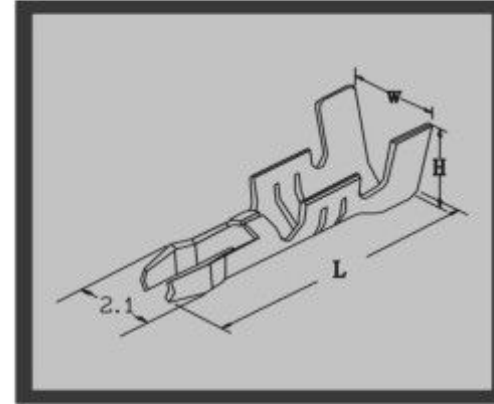

型号: SCP1.8-4.5(HA6018)
Part NO: SCP1.8-4.5
适用导线: AWG#22-18
Wire Range: AWG#22-18
表面处理: 镀锡
Finish: Tin-plated
材料: 磷青铜
Material: Phosphor Bronze

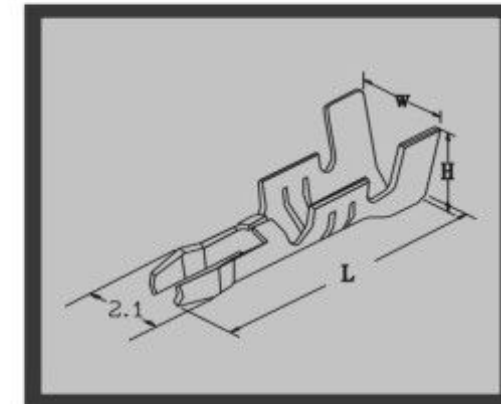

型号: 金针压接端子(HA6037)
Part NO: 金针压接端子
表面处理: 本色
Finish: Nono
材料: 黄铜(H62)
Material: Brass(H62)

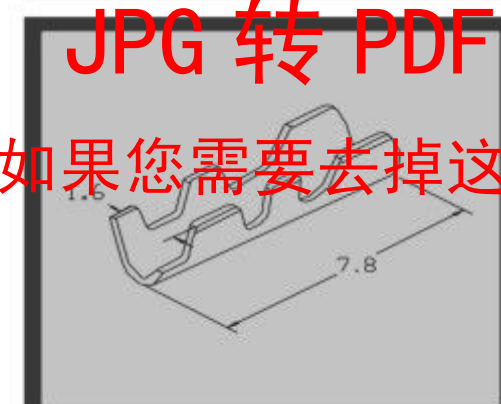

连接器配件图

Connector Component

JPG 转 PDF 转换器 – 未注册版

如果您需要去掉这行字，请注册 JPG 转 PDF 转换器

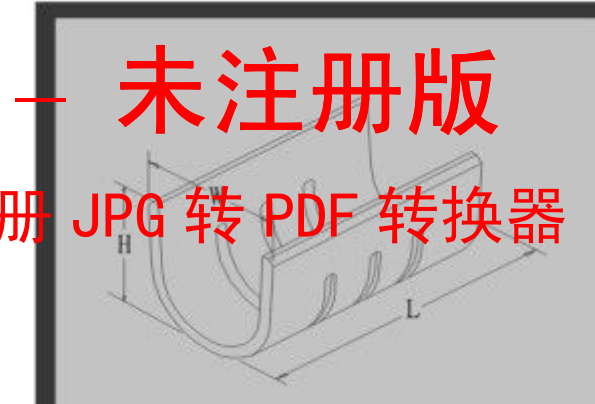

类号Part NO	适用导线Wire range mm ²	尺寸Size(mm)				表面处理 Finish	材质 Material
		W	L	H	厚度Thickness		
电线接头A	0.4-0.8	2.5	3	2.2	0.25	酸洗	黄铜Brass (H62)
电线接头B	0.8-2.2	4	5.2	3.8	0.4		
电线接头C	3.0-5.5	7	6.2	5.6	0.5		
电线接头D	2.7-6.0	6.7	7.3	6.6	0.5		
电线接头E	0.75-2.0	3.6	6	3.5	0.3		

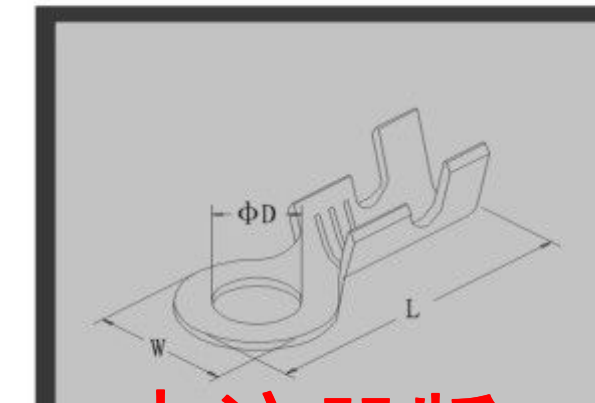

类号Part NO	适用导线Wire range		尺寸Size(mm)				表面处理 Finish	材质 Material
	AWG#	线径	W	L	ΦD	厚度Thickness		
SRM3-6	22-18	2.6-3.1	6	12.2	3.2	0.3	亚光	黄铜Brass (H62)
SRM4-7.5	20-16		7.5	16.6	4.3	0.4		
SRM4-6.5			6.5	17.5	4.3	0.6		
SRM5-7.5			7.5	16.5	5.1	0.6		

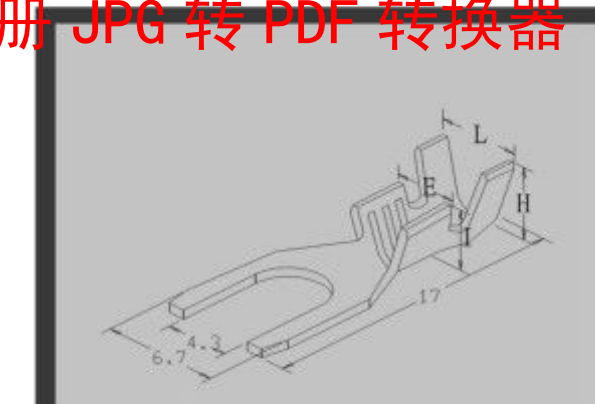

类号Part NO	适用导线Wire range		尺寸Size(mm)				表面处理 Finish	材质 Material	
	AWG#	线径	L	H	E	I			厚度Thickness
SAM4-6.7A	22-18	2.6-3.1	4.9	4.6	3.7	3.1	0.6	亚光	黄铜Brass (H62)
SAM4-6.7B	20-16	2.8-3.8	5.4	5.2	4	3.9	0.6		

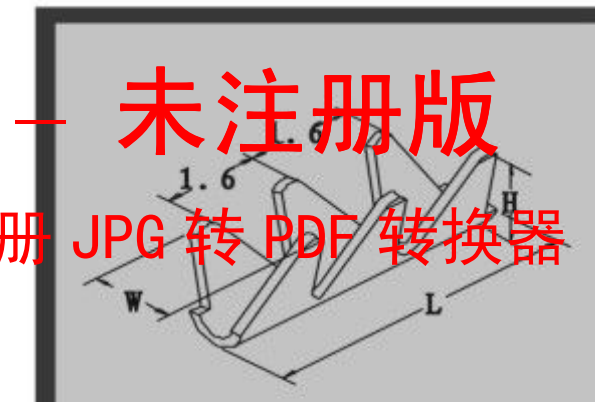

类号Part NO	适用导线Wire range mm ²	尺寸Size(mm)				表面处理 Finish	材质 Material
		W	L	H	厚度Thickness		
XK-2.1	0.3-0.7	2.1	7	2.6	0.25	酸洗	黄铜Brass (H62)
XK-2.7	0.4-0.8	3	7	3.4	0.25		

JPG 转 PDF 转换器 – 未注册版

如果您需要去掉这行字，请注册 JPG 转 PDF 转换器

JPG 转 PDF 转换器 – 未注册版

如果您需要去掉这行字，请注册 JPG 转 PDF 转换器

连接器配件图 Connector Component

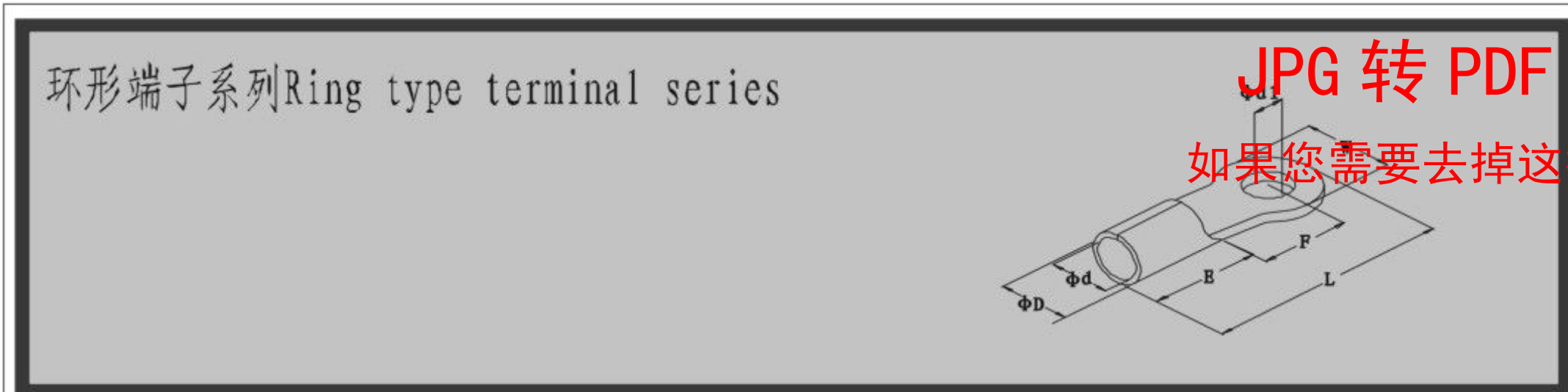

编号Part NO	适用导线Wire range		尺寸Size(mm)							厚度 Thickness	表面处理 Finish	材质 Material
	AWG#	线径Diameter	Φd1	W	L	F	E	ΦD	Φd			
RNB1.25-3.2	22-16	0.25-1.6	3.2	5.7	12.6	4.95	4.8	3.4	1.7	0.8	镀锡 Tin-plated	黄铜 Brass (H62)
RNB1.25-3.7S			3.7	5.7	12.6	4.95						
RNB1.25-3.7M			3.7	6.6	14.4	6.3						
RNB1.25-3.7L			3.7	8.0	15.8	7.0						
RNB1.25-4S			4.3	6.6	14.4	6.3						
RNB1.25-4L			4.3	8.0	15.8	7.0						
RNB1.25-5			5.3	8.0	15.8	7.0						
RNB1.25-6			6.5	11.6	21.8	11.1						
RNB1.25-8			8.4	11.6	21.8	11.1						
RNB1.25-10			10.5	13.6	25.5	13.9						
RNB2-3.2	16-14	1.04-2.6	3.2	6.6	12.3	4.3	4.8	4.0	2.3	0.8	镀锡 Tin-plated	黄铜 Brass (H62)
RNB2-3.7S			3.7	6.6	12.3	4.3						
RNB2-3.7M			3.7	6.6	16.0	7.0						
RNB2-3.7L			3.7	8.5	16.8	7.75						
RNB2-4S			4.3	6.6	16.0	7.0						
RNB2-4L			4.3	8.5	16.8	7.75						
RNB2-5S			5.3	8.5	16.8	7.75						
RNB2-5L			5.3	9.5	16.8	7.25						
RNB2-6			6.5	12.0	21.8	11.0						
RNB2-8			8.4	12.0	21.8	11.0						
RNB2-10	10.5	13.6	25.5	13.9								
RNB3.5-4	14-12	2.5-4.0	4.3	8.0	18.0	7.7	6.0	5.0	3.0	1.0	镀锡 Tin-plated	黄铜 Brass (H62)
RNB3.5-5S			5.3	8.0	18.0	7.7						
RNB3.5-5L			5.3	12.0	21.4	7.7						
RNB3.5-6			6.5	12.0	21.4	7.7						
RNB5.5-3.5	12-10	4.0-6.0	3.7	7.2	15.7	5.9	6.8	5.5	3.4	1.0	镀锡 Tin-plated	黄铜 Brass (H62)
RNB5.5-4S			4.3	7.2	15.7	5.9						
RNB5.5-4L			4.3	9.5	19.8	8.3						
RNB5.5-5			5.3	9.5	19.8	8.3						
RNB5.5-6			6.5	12.0	25.8	13.0						
RNB5.5-8			8.4	15.0	28.0	13.7						
RNB5.5-10			10.5	15.0	28.0	13.7						
RNB5.5-12			13.0	19.2	32.4	16.0						

连接器配件图 Connector Component



编号Part NO	适用导线Wire range		尺寸Size(mm)							厚度 Thickness	表面处理 Finish	材质 Material	颜色 Color
	AWG#	线径Diameter	Φd1	W	L	F	H	ΦD					
ERV1.25-3.2	22-16	0.25-1.6	3.2	5.7	17.8	4.95	10.5	4.1	0.8	镀锡 Tin-plated	黄铜 Brass (H62)	红 Red	
ERV1.25-3.7S			3.7	5.7	17.8	4.95							
ERV1.25-3.7M			3.7	6.6	20.1	6.3							
ERV1.25-3.7L			3.7	8.0	21.5	7.0							
ERV1.25-4S			4.3	6.6	20.1	6.3							
ERV1.25-4L			4.3	8.0	21.5	7.0							
ERV1.25-5			5.3	8.0	21.5	7.0							
ERV1.25-6			6.5	11.6	27.5	11.1							
ERV1.25-8			8.4	11.6	27.5	11.1							
ERV1.25-10			10.5	13.6	25.5	13.9							
ERV2-3.2	16-14	1.04-2.6	3.2	6.6	17.8	4.3	11.0	4.5	0.8	镀锡 Tin-plated	黄铜 Brass (H62)	蓝 Blue	
ERV2-3.7S			3.7	6.6	17.8	4.3							
ERV2-3.7M			3.7	6.6	21.0	7.0							
ERV2-3.7L			3.7	8.5	22.5	7.75							
ERV2-4S			4.3	6.6	21.0	7.0							
ERV2-4L			4.3	8.5	22.5	7.75							
ERV2-5S			5.3	8.5	22.5	7.75							
ERV2-5L			5.3	9.5	22.5	7.25							
ERV2-6			6.5	12.0	27.6	11.0							
ERV2-8			8.4	12.0	27.6	11.0							
ERV2-10	10.5	13.6	30.2	13.9									
ERV3.5-4	14-12	2.5-4.0	4.3	8.0	24.5	7.7	12.5	6.2	1.0	镀锡 Tin-plated	黄铜 Brass (H62)	黑 Black	
ERV3.5-5S			5.3	8.0	24.5	7.7							
ERV3.5-5L			5.3	12.0	27.9	7.7							
ERV3.5-6			6.5	12.0	27.9	7.7							
ERV5.5-3.5	12-10	4.0-6.0	3.7	7.2	21.4	5.9	14.0	6.8	1.0	镀锡 Tin-plated	黄铜 Brass (H62)	黄 Yellow	
ERV5.5-4S			4.3	7.2	21.4	5.9							
ERV5.5-4L			4.3	9.5	25.5	8.3							
ERV5.5-5			5.3	9.5	25.5	8.3							
ERV5.5-6			6.5	12.0	31.5	13.0							
ERV5.5-8			8.4	15.0	33.7	13.7							
ERV5.5-10			10.5	15.0	33.7	13.7							
ERV5.5-12			13.0	19.2	38.1	16.0							

JPG 转 PDF 转换器 – 未注册版

如果您需要去掉这行字, 请注册 JPG 转 PDF 转换器

U型端子系列 U-shaped terminal series

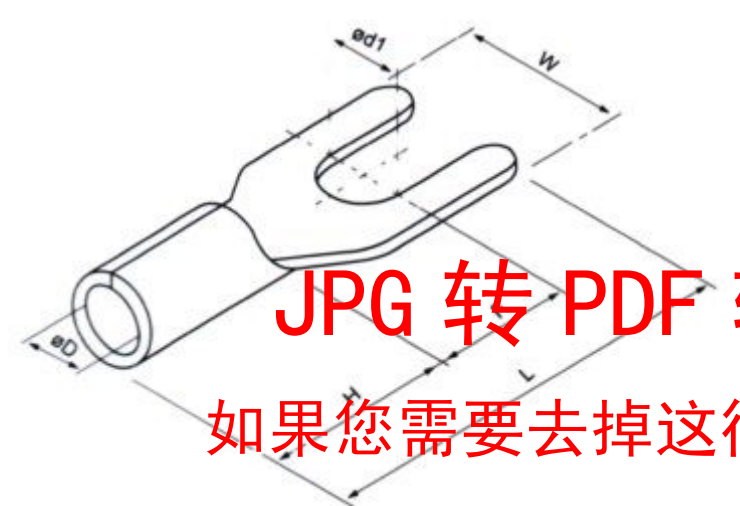

JPG 转 PDF 转换器 – 未注册版

如果您需要去掉这行字, 请注册 JPG 转 PDF 转换器

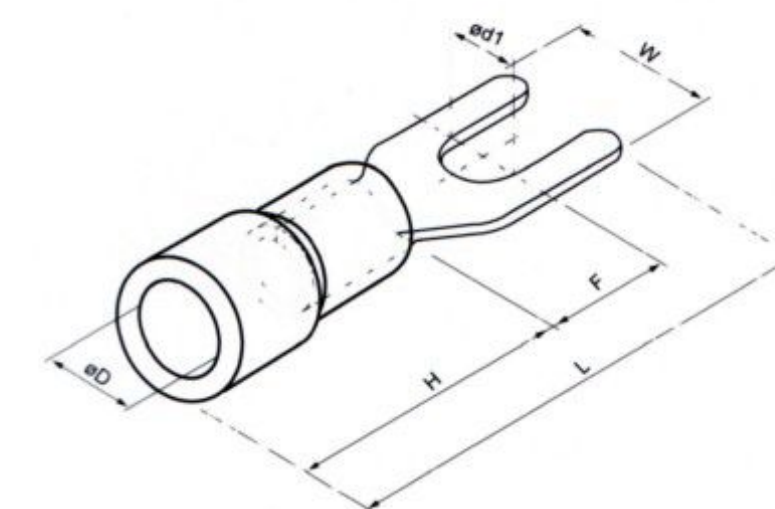

编号Part NO	适用导线Wire range		尺寸Size(mm)							表面处理 Finish	材质 Material	相当品番JST Equivalent code of product JST							
	AWG#	mm ²	φd1	W	L	F	E	φD	厚度Thickness										
HATU320ASBT	22-16	0.25-1.6	3.2	5.7	16.0	6.5	10.0	1.7	0.8	镀锡 Tin-plated	黄铜 Brass (H62)	1.25-B3A							
HATU370ASBT			3.7	5.7	16.0	6.5						1.25-B3.5A							
HATU370BSBT			3.7	6.4	16.0	6.5						1.25-YS3A							
HATU430ASBT			4.3	6.4	16.0	6.5						1.25-YS4A							
HATU430BSBT			4.3	7.2	16.0	6.5						1.25-S4A							
HATU430CSBT			4.3	8.1	16.0	6.5						-							
HATU530ASBT			5.3	8.1	16.0	6.5						-							
HATU530BSBT			5.3	9.5	16.0	6.5						-							
HATU650ASBT			6.5	9.5	16.0	6.5						-							
HATU650BSBT			6.5	12.0	22.0	11.0						-							
HATU320AMBT			16-14	1.04-2.6	3.2	5.7						16.0	6.5	10.0	2.3	0.8	镀锡 Tin-plated	黄铜 Brass (H62)	1.25-6A
HATU370AMBT					3.7	5.7						16.0	6.5						2-N3A
HATU370BNBT	3.7	6.0			16.0	6.5	2-C3.5A												
HATU430AMBT	4.3	6.4			16.0	6.5	-												
HATU430BMBT	4.3	7.2			16.0	6.5	2-YS4A												
HATU430CMBT	4.3	8.1			16.0	6.5	2S4A												
HATU530AMBT	5.3	8.1			16.0	6.5	-												
HATU530BMBT	5.3	9.5			16.0	6.5	2-5A												
HATU650AMBT	6.5	9.5			16.0	6.5	-												
HATU650BMBT	6.5	12.0			22.0	11.0	2-6A												
HATU430ALBT	14-12	2.5-4.0			4.3	8.0	18.3	7.0	12.5	3.0	1.0	镀锡 Tin-plated	黄铜 Brass (H62)						-
HATU530ALBT					5.3	8.0	18.3	7.0											-
HATU650ALBT			6.5	12.0	21.5	12.1	-												
HATU370ATBT	12-10	4.0-6.0	3.7	8.3	19.5	7.5	12.5	3.4	1.0	镀锡 Tin-plated	黄铜 Brass (H62)	-							
HATU430ATBT			4.3	8.3	19.5	7.5						5.5-S4A							
HATU430BTBT			4.3	9.0	18.2	7.5						-							
HATU530ATBT			5.3	9.0	18.2	7.5						-							
HATU650ATBT			6.5	9.0	18.2	7.5						-							
HATU650BTBT			6.5	12.0	25.5	12.0						-							
HATU840ATBT			8.4	14.0	24.5	11.5						-							

JPG 转 PDF 转换器 – 未注册版

如果您需要去掉这行字, 请注册 JPG 转 PDF 转换器

编号Part NO	适用导线Wire range		尺寸Size(mm)							表面处理 Finish	材质 Material	颜色 Color	相当品番JST Equivalent code of product JST									
	AWG#	mm ²	φd1	W	L	F	H	φD	厚度Thickness													
HATU320ASBT	22-16	0.25-1.6	3.2	5.7	21.2	6.5	10.0	4.3	0.8	镀锡 Tin-plated	黄铜 Brass (H62)	红 Red	FV1.25-B3A									
HATU370ASBT			3.7	5.7								-										
HATU370BSBT			3.7	6.4								FV1.25-YS3A										
HATU430ASBT			4.3	6.4								FV1.25-YS4A										
HATU430BSBT			4.3	7.2								FV1.25-S4A										
HATU430CSBT			4.3	8.1								-										
HATU530ASBT			5.3	8.1								-										
HATU530BSBT			5.3	9.5								FV1.25-5A										
HATU650ASBT			6.5	9.5								-										
HATU650BSBT			6.5	12.0								27.2	11.0	FV1.25-6A								
HATU320AMBT			16-14	1.04-2.6								3.2	5.7	21.2	6.5	10.0	4.9	0.8	镀锡 Tin-plated	黄铜 Brass (H62)	蓝 Blue	FV2-N3A
HATU370AMBT												3.7	5.7								-	
HATU370BNBT	3.7	6.0			-																	
HATU430AMBT	4.3	6.4			FV2-YS4A																	
HATU430BMBT	4.3	7.2			FV2-S4A																	
HATU430CMBT	4.3	8.1			-																	
HATU530AMBT	5.3	8.1			-																	
HATU530BMBT	5.3	9.5			FC2-5A																	
HATU650AMBT	6.5	9.5			-																	
HATU650BMBT	6.5	12.0			27.2	11.0	FV2-6A															
HATU430ALBT	14-12	2.5-4.0			4.3	8.0	24.8	7.0	12.5	6.2	1.0	镀锡 Tin-plated	黄铜 Brass (H62)								黑 Black	-
HATU530ALBT					5.3	8.0															-	
HATU650ALBT			6.5	12.0	28.0	12.1								-								
HATU370ATBT	12-10	4.0-6.0	3.7	8.3	23.9	7.5	12.5	6.7	1.0	镀锡 Tin-plated	黄铜 Brass (H62)	黄 Yellow	-									
HATU430ATBT			4.3	8.3								FV5.5-S4A										
HATU430BTBT			4.3	9.0								-										
HATU530ATBT			5.3	9.0								-										
HATU650ATBT			6.5	9.0								-										
HATU650BTBT			6.5	12.0								31.2	12.0	-								
HATU840ATBT			8.4	14.0								30.0	11.5	-								

JPG 转 PDF 转换器 – 未注册版

如果您需要去掉这行字, 请注册 JPG 转 PDF 转换器

JPG 转 PDF 转换器 — 未注册版

如果您需要去掉这行字，请注册 JPG 转 PDF 转换器

连接器配件图 Connector Component

型号: 250-5P
Part NO: 250-5P
材料: 尼龙66
Material: Nylon 66

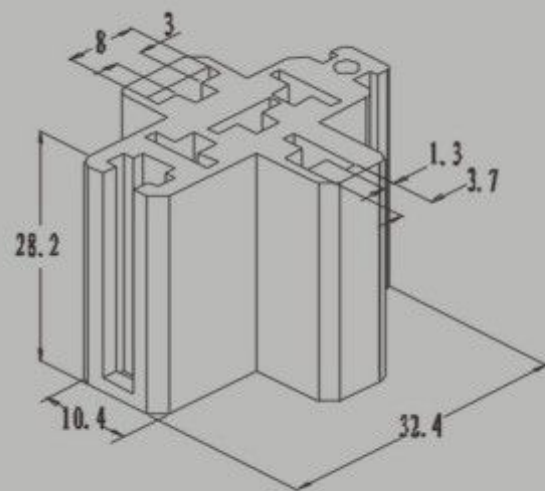

型号: 250-2P
Part NO: 250-2P
材料: 尼龙66
Material: Nylon 66

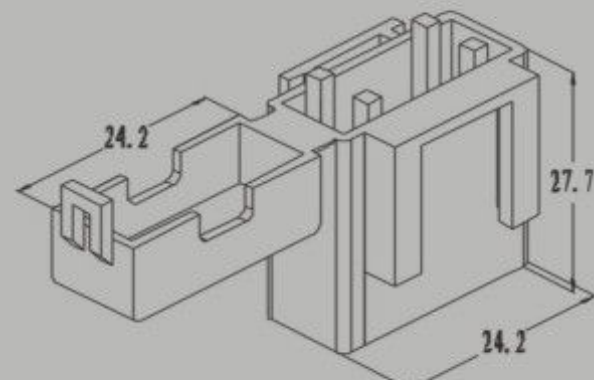

型号: 205-2P
Part NO: 205-2P
材料: 尼龙66
Material: Nylon 66

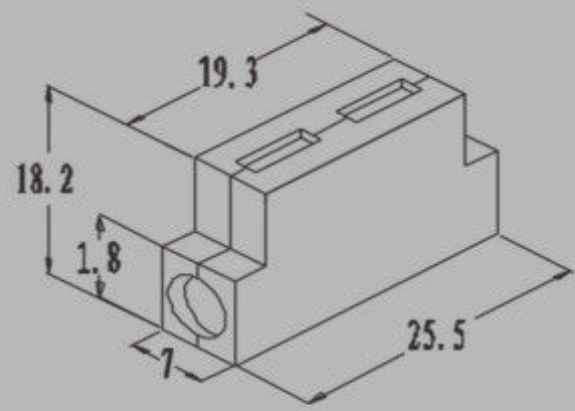

型号: 250TM-6P
Part NO: 250TM-6P
材料: 尼龙66
插片: 黄铜 (H62)
Material: Nylon 66
Brass (H62)

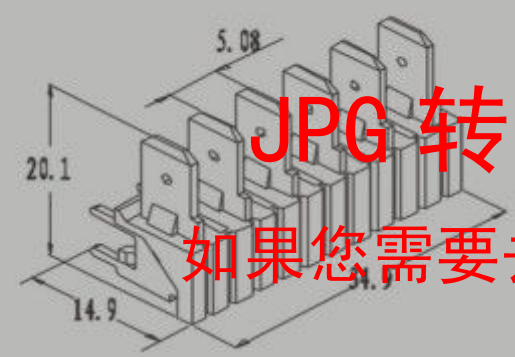

JPG 转 PDF 转换器 — 未注册版

如果您需要去掉这行字，请注册 JPG 转 PDF 转换器

JPG 转 PDF 转换器 — 未注册版

如果您需要去掉这行字，请注册 JPG 转 PDF 转换器

JPG 转 PDF 转换器 — 未注册版

如果您需要去掉这行字，请注册 JPG 转 PDF 转换器



设计室



检测室



冲压车间



冲压车间



注塑车间



电加工车间

JPG 转 PDF 转换器 - 未注册版

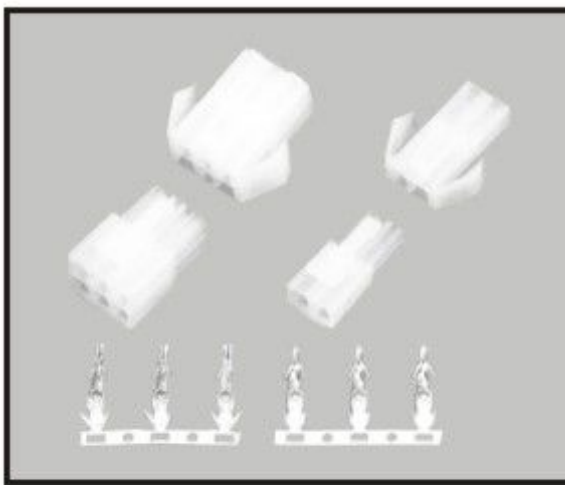

小型EL(4.5mm)

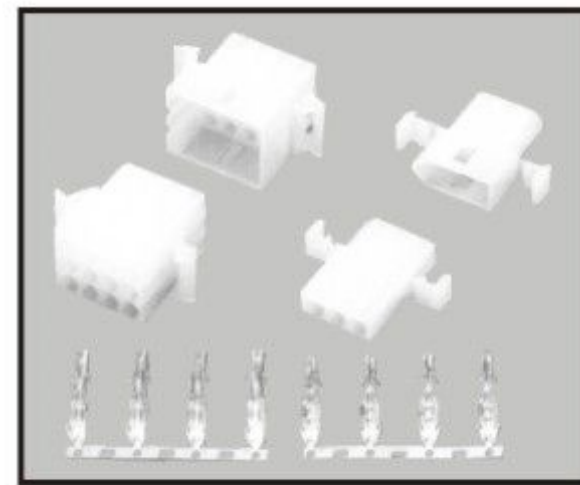

50300, 50301(5.03mm)

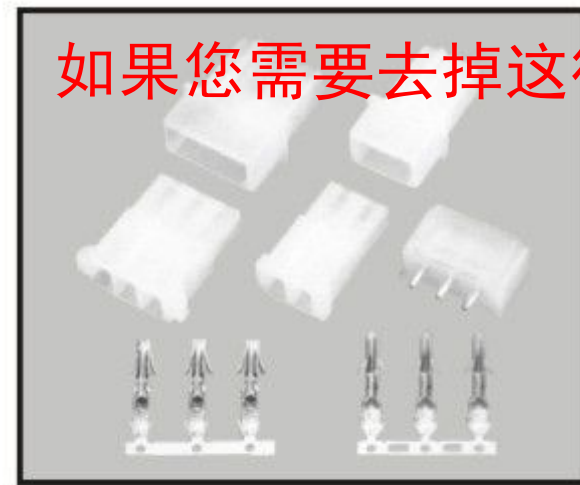

8981/大四P(5.08mm)

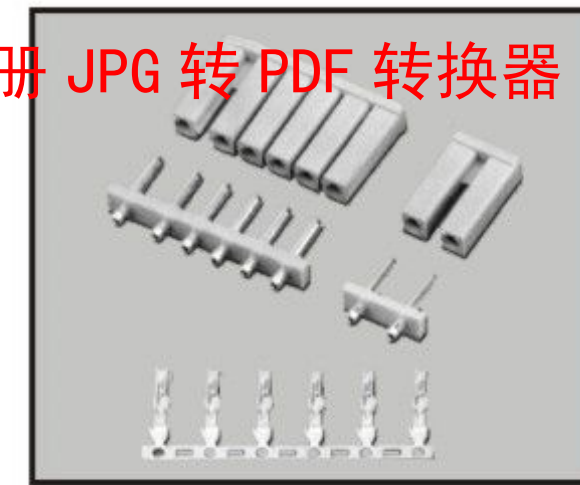

TJC4(8-6...6mm)



TJC1(10-8...8mm)

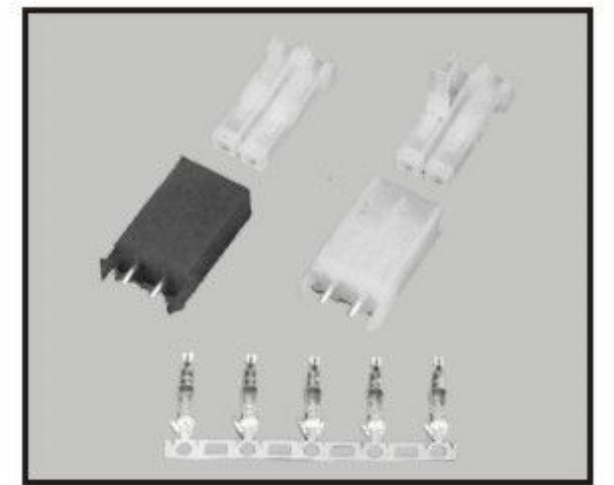

SMF(4.5mm)

如果您需要去掉这行字, 请注册 JPG 转 PDF 转换器

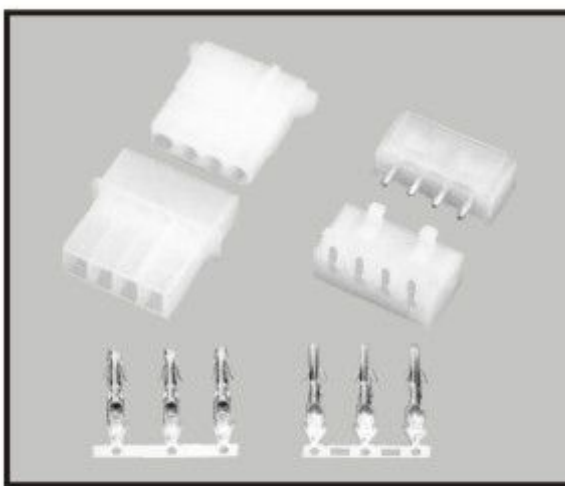

8981/大四P(5.08mm)

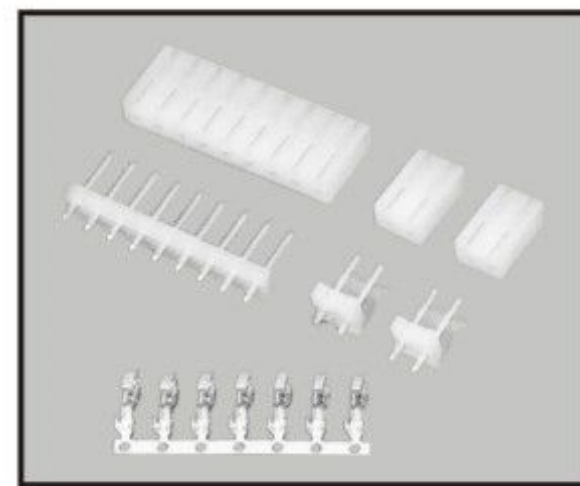

5058/5.08(5.08mm)



5025(5.5mm)



Cy-X201/35108(8.0/5.0mm)

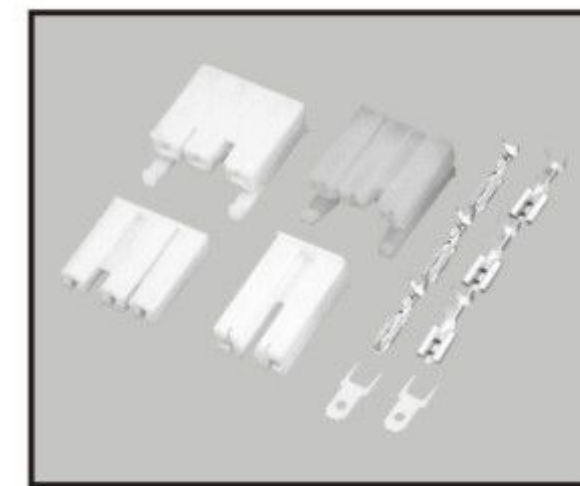

(4.8直插/2.8喇叭插) 洗衣机系列

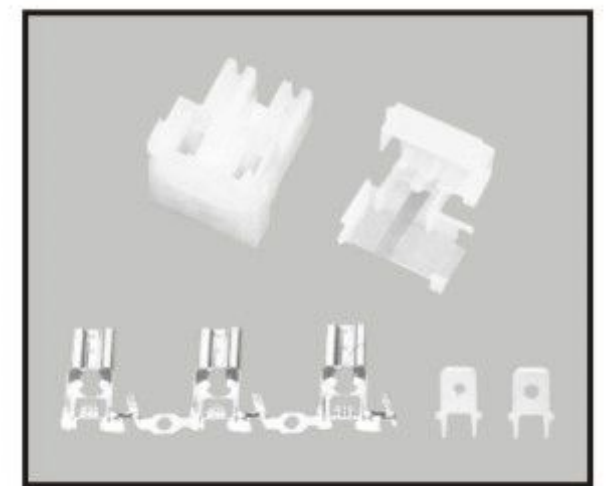

(6.3横插带锁) 洗衣机系列

JPG 转 PDF 转换器 - 未注册版
如果您需要去掉这行字, 请注册 JPG 转 PDF 转换器

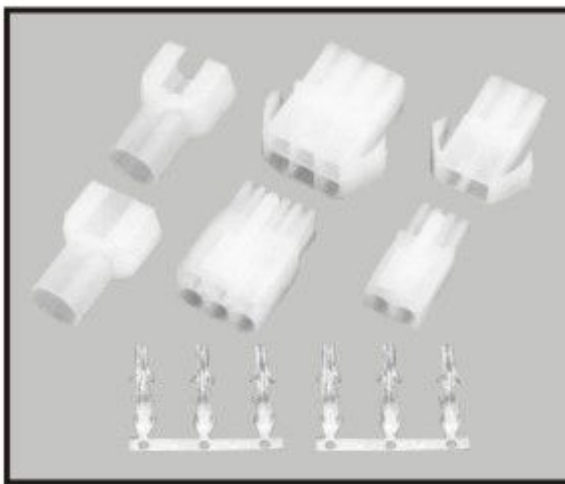

L6.2(6.2mm)

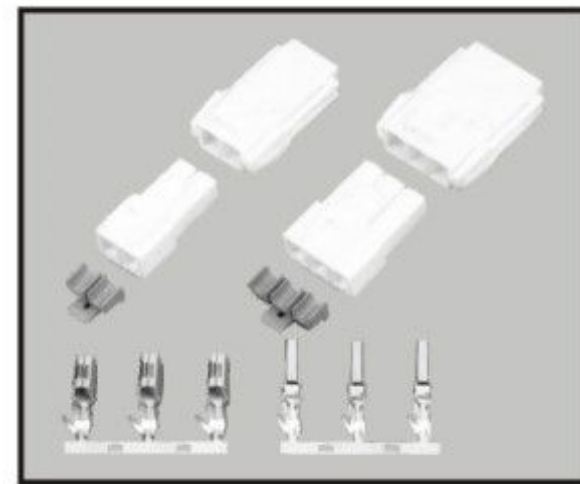

VL(6.2mm)

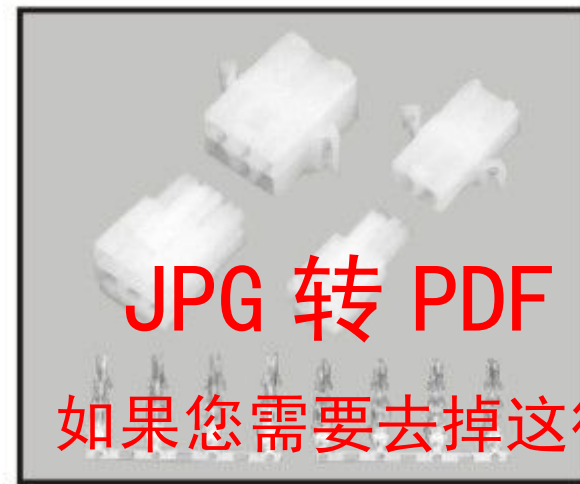

3191(6.7mm)

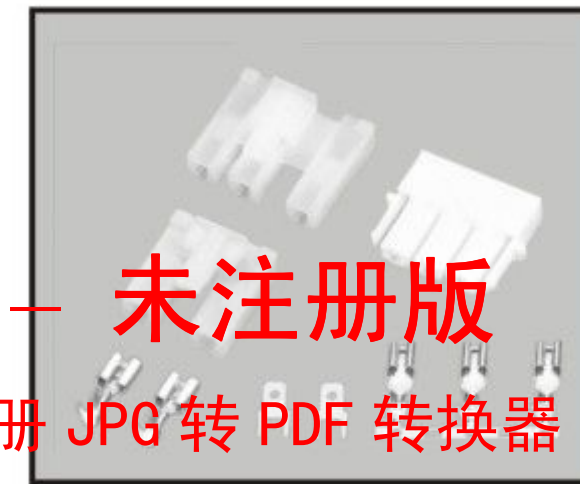

(4.8直插) 洗衣机系列

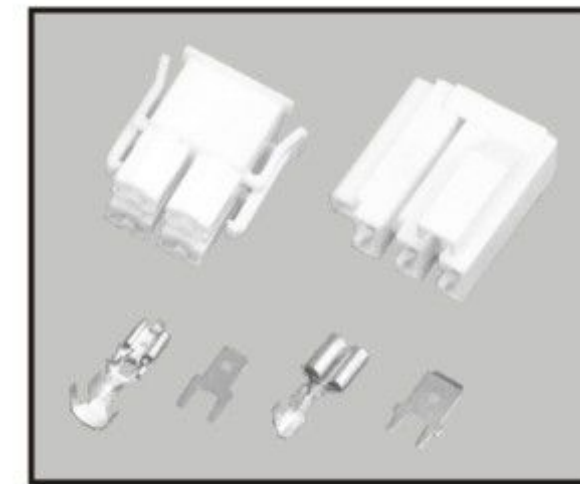

(4.8带锁/6.3轻插) 洗衣机系列

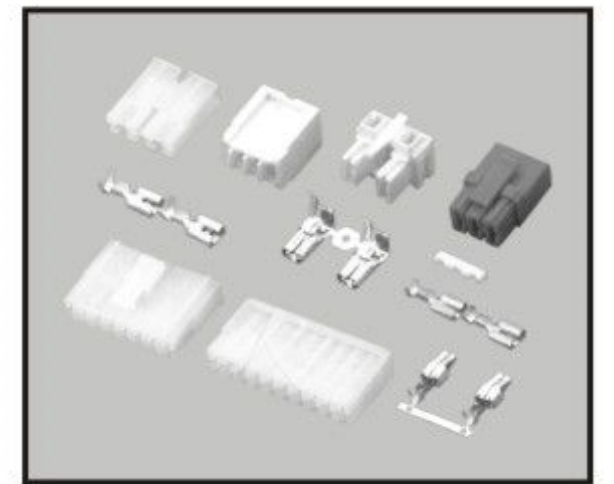

洗衣机系列

JPG 转 PDF 转换器 - 未注册版
如果您需要去掉这行字, 请注册 JPG 转 PDF 转换器

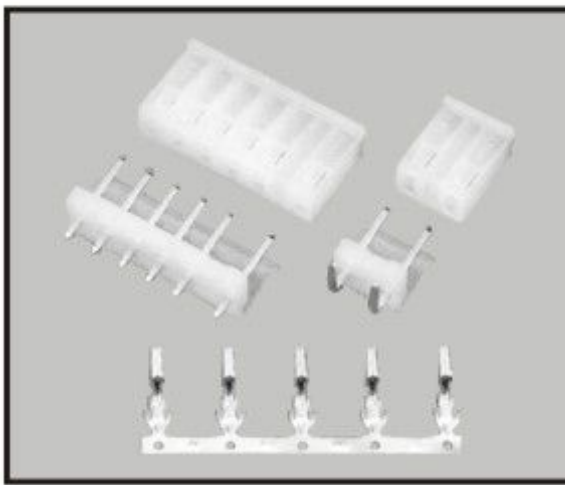

5199(7.5-5-...5mm)

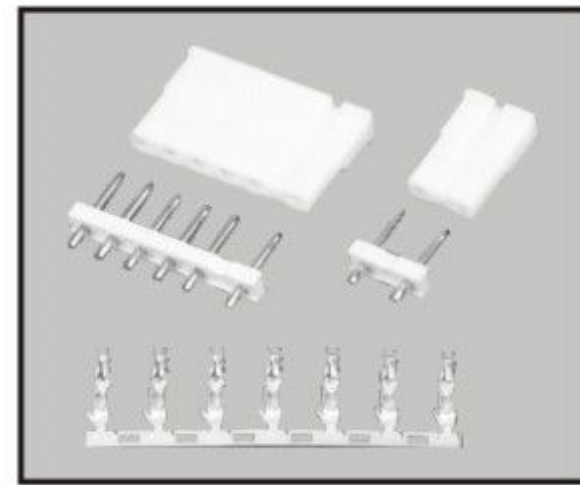

TJC2(7.5-5...5mm)

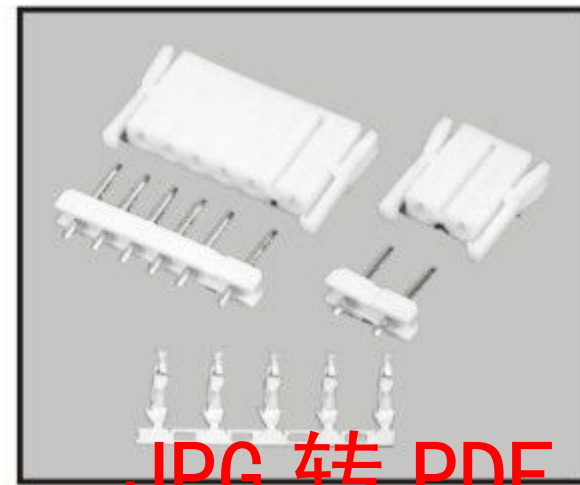

TJC2A(7.5-5...5mm)



35150, 35151 (6.2/7.3/7.8/8.9mm)

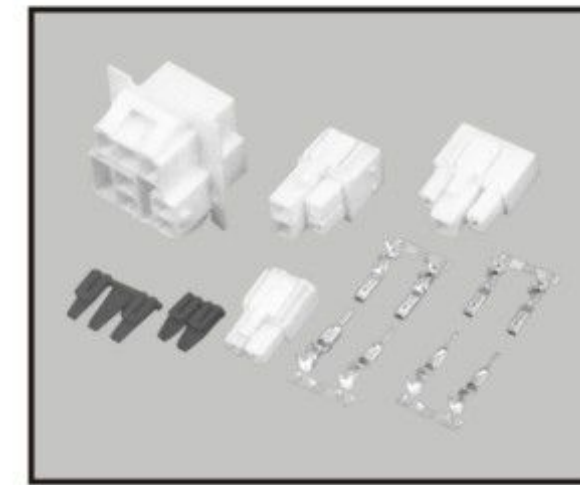

35524 (6.2/7.3/7.8/8.9mm)



35180 (8.0/8.5mm)

JPG 转 PDF 转换器 - 未注册版
如果您需要去掉这行字, 请注册 JPG 转 PDF 转换器

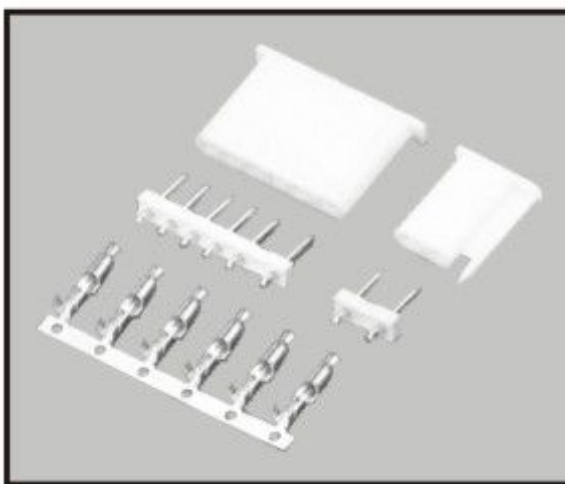

TJC2B(7.5-5-...5mm)

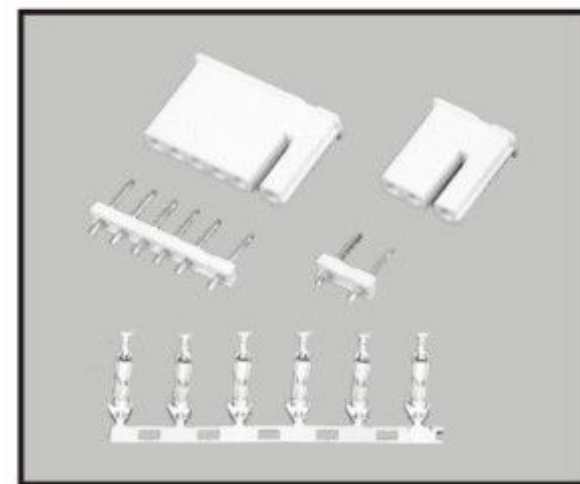

STV5(7.5-5...5mm)



YHL-500(7.5-5...5mm)



1806 (6.0/6.6mm)

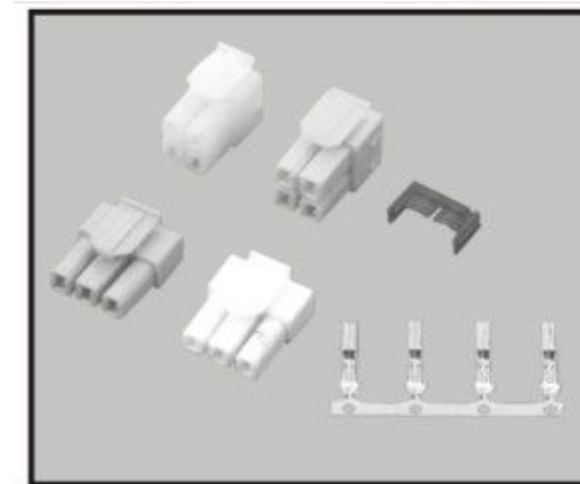

1806 (6.0/6.6mm)

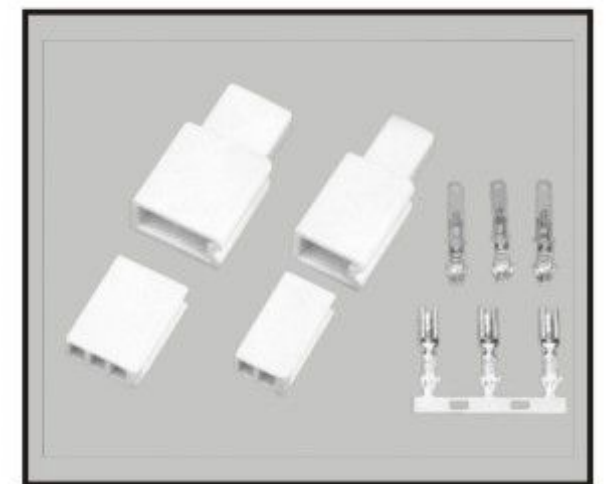

HX28000/110 (4.0mm)

JPG 转 PDF 转换器 — 未注册版

如果您需要去掉这行字，请注册 JPG 转 PDF 转换器

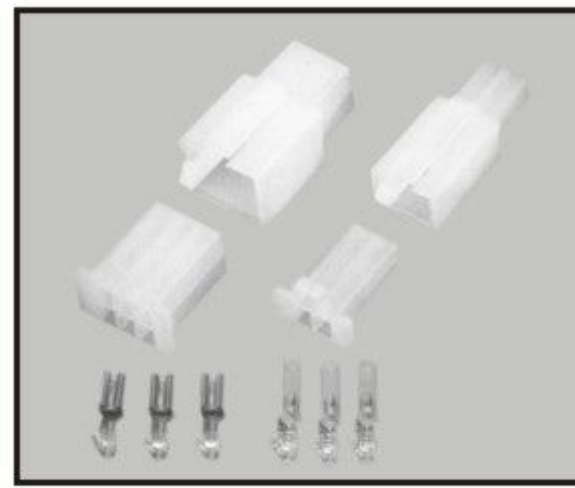

28050(4.0/5.0mm)

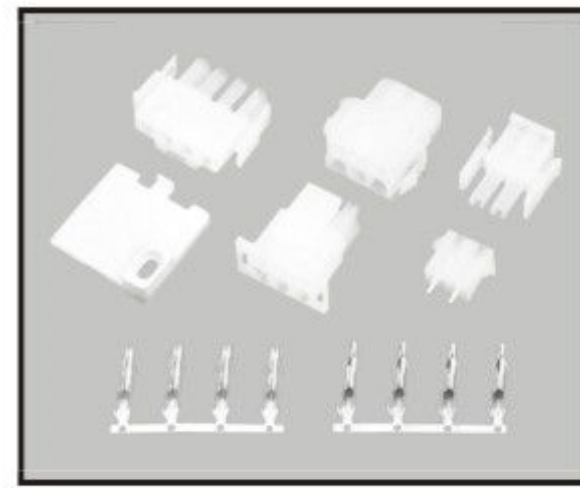

63080/42021、42022(6.3mm)

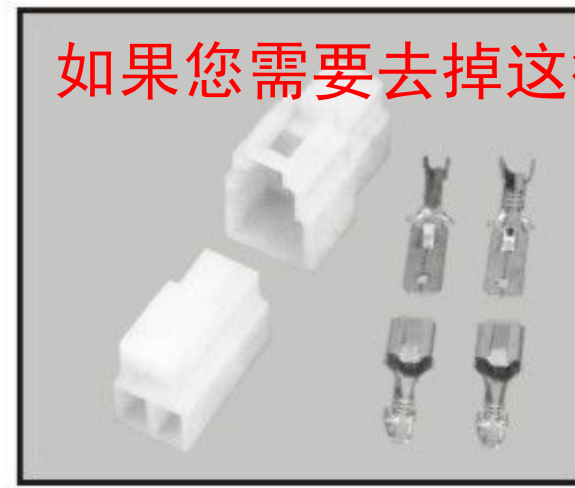

63090(9.0/6.0mm)



(6.3直播) 硬护套系列

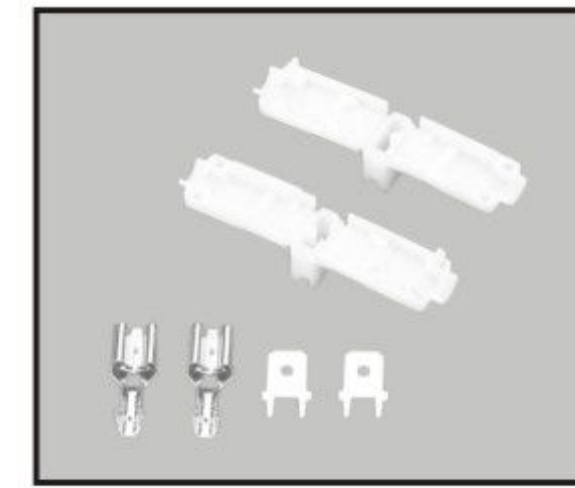

(6.3带锁) 硬护套

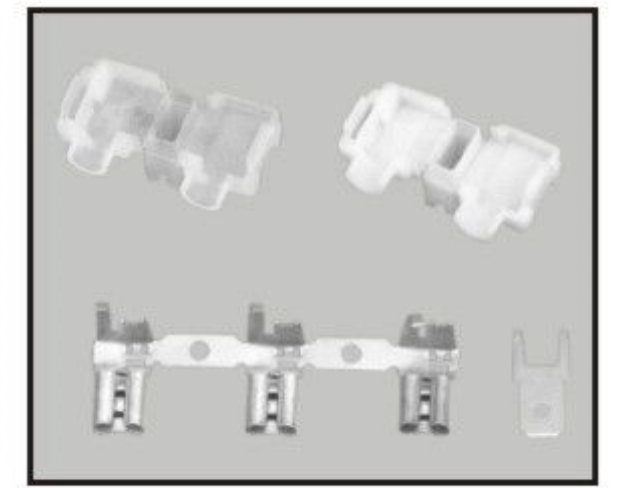

(4.8旗形) 硬护套系列



63092(9.0/5.5mm)

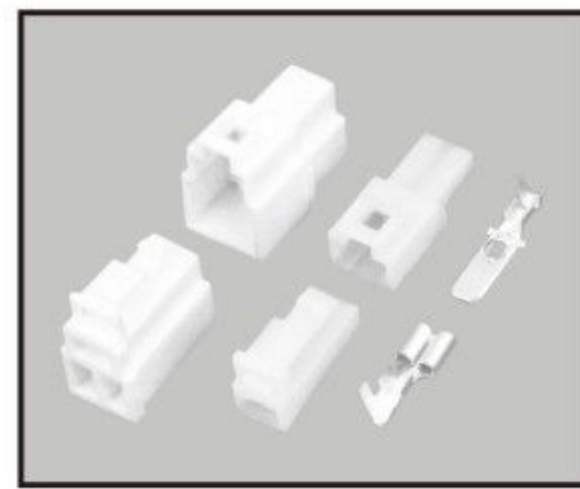

(35955)车用系列连接器

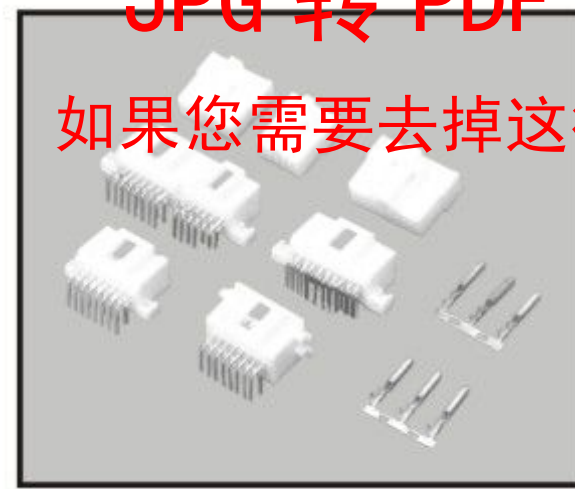

SA(2.54mm)



(4.8旗形带锁) 硬护套系列

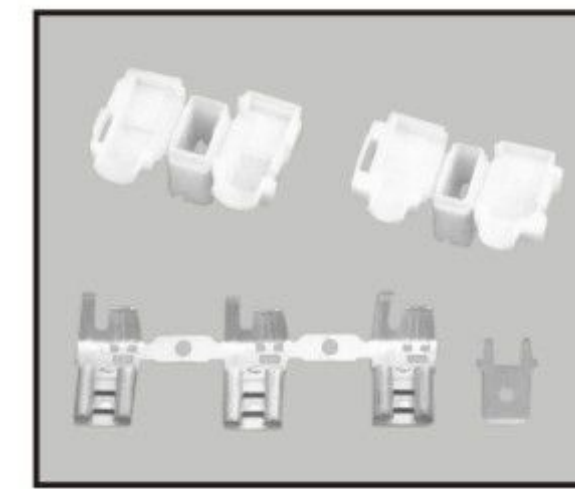

(6.3旗形) 硬护套系列

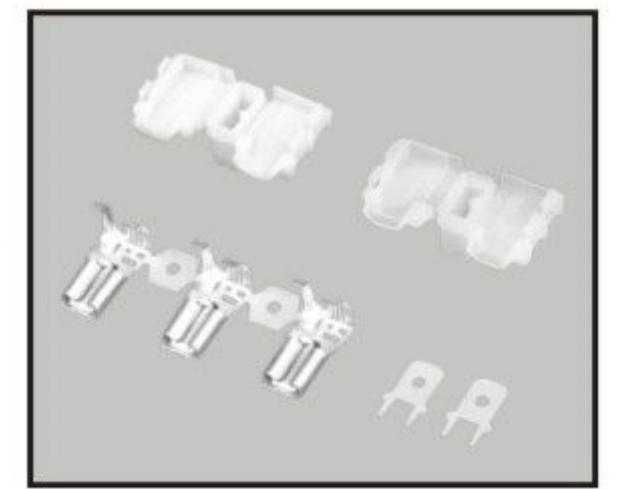

(6.3旗形带锁) 硬护套

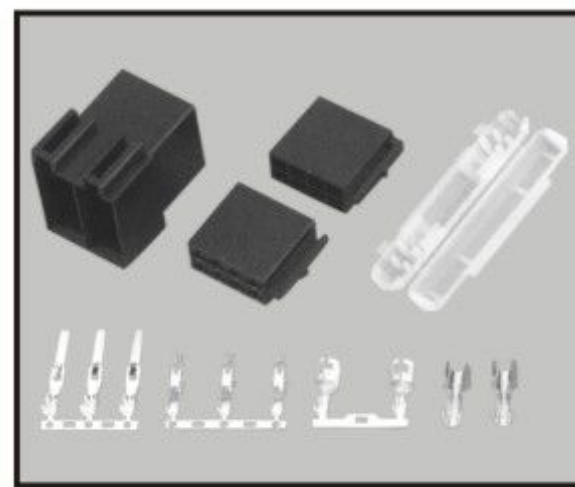

车用系列连接器

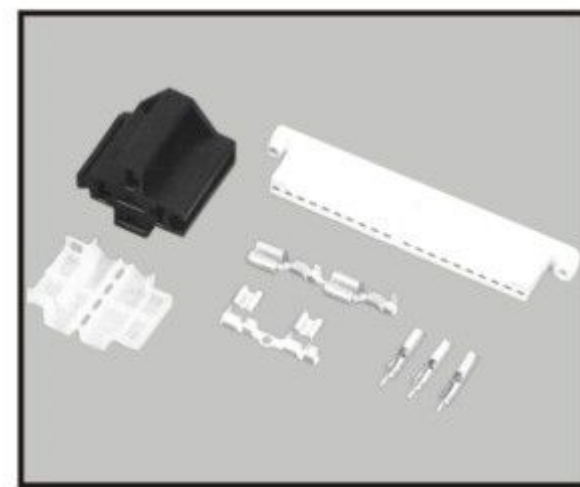

车用系列连接器

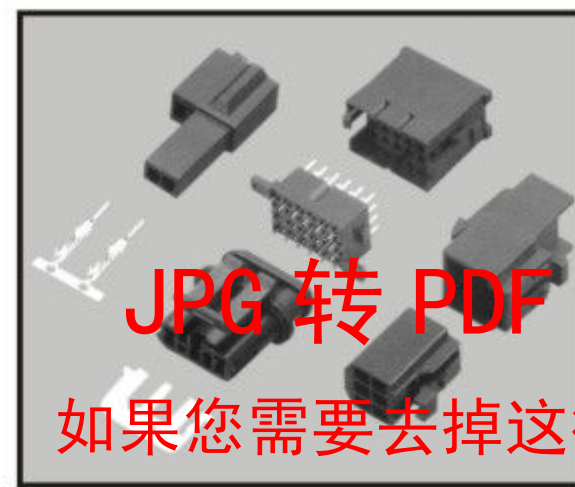

车用系列连接器



(6.3枪形) 硬护套

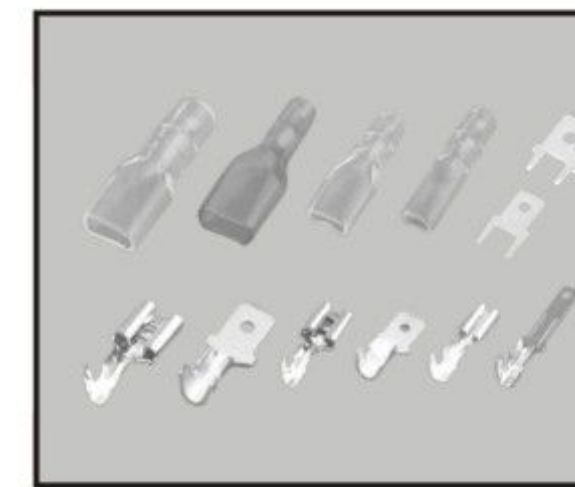

(2.8/4.8/6.3直播) 软护套

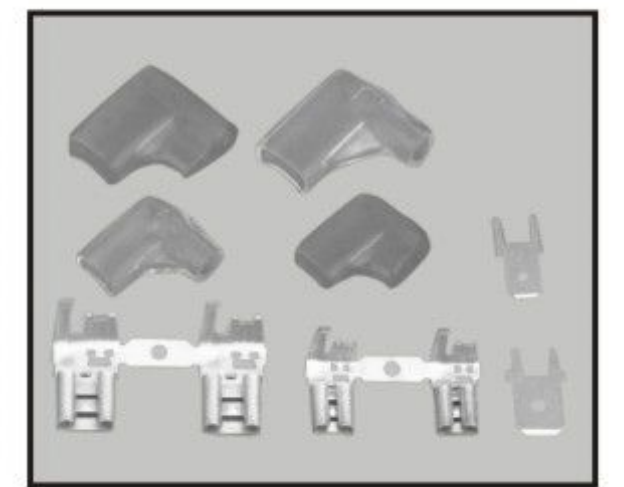

(4.8/6.3旗形) 软护套

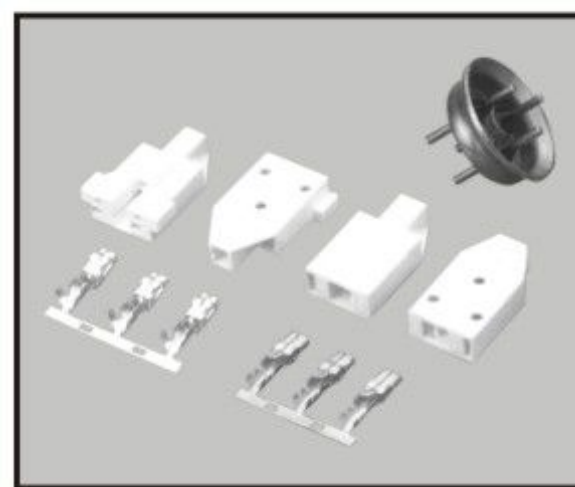

SCS空调、冰箱插件

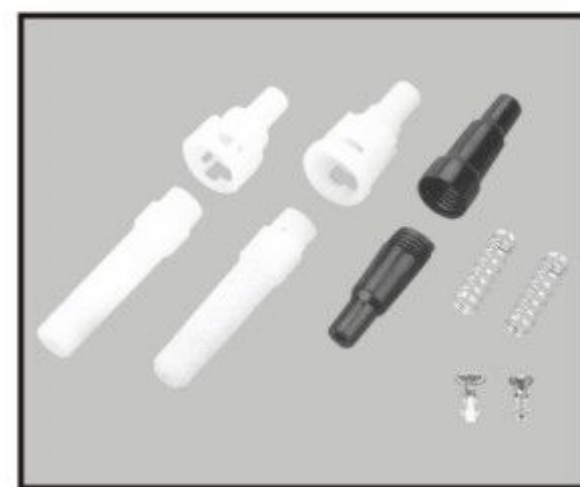

车用系列连接器

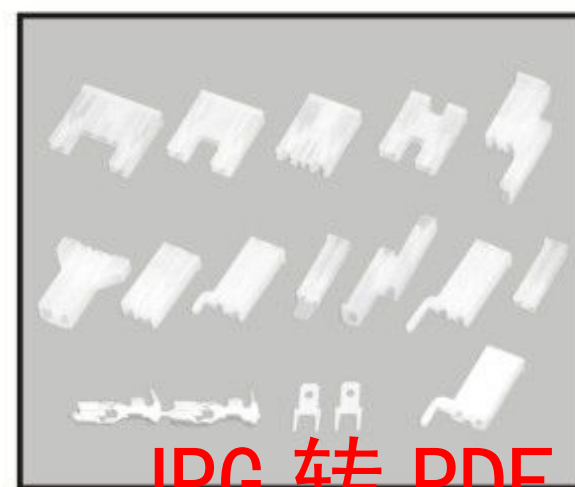

微波炉系列

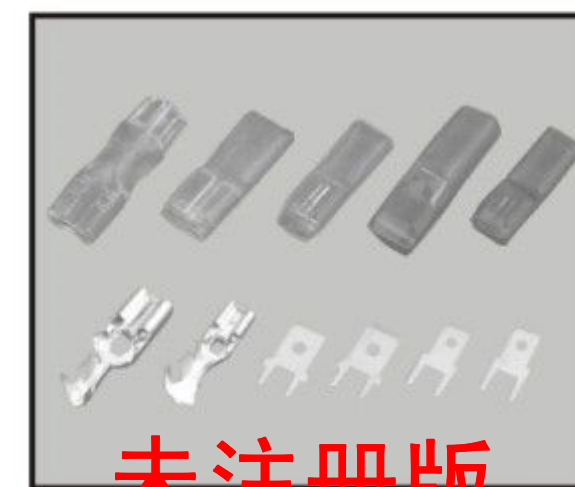

(2.8/4.8/5.2/6.3直播带锁) 软护套

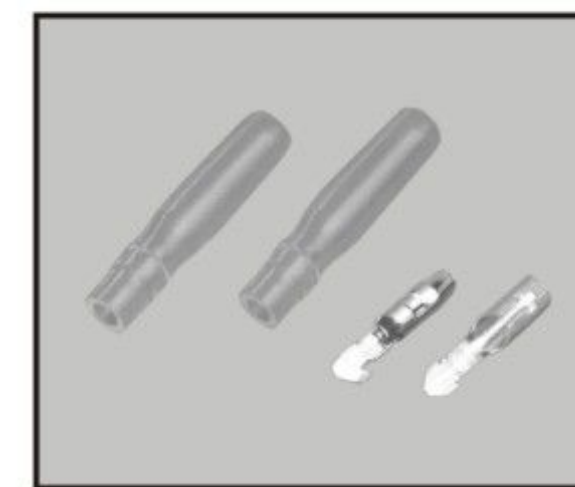

子弹形软护套

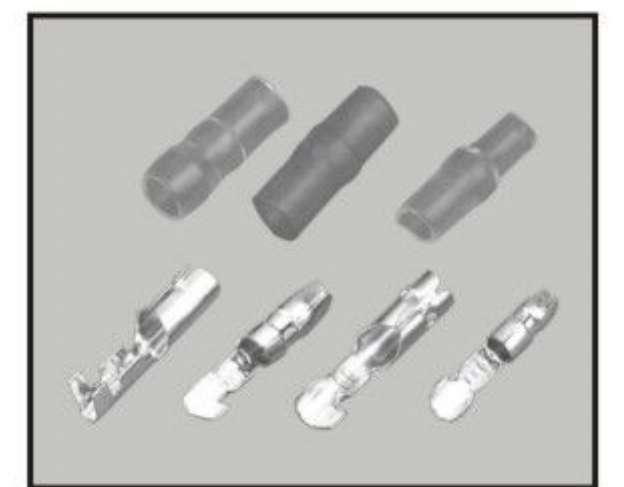

子弹形软护套

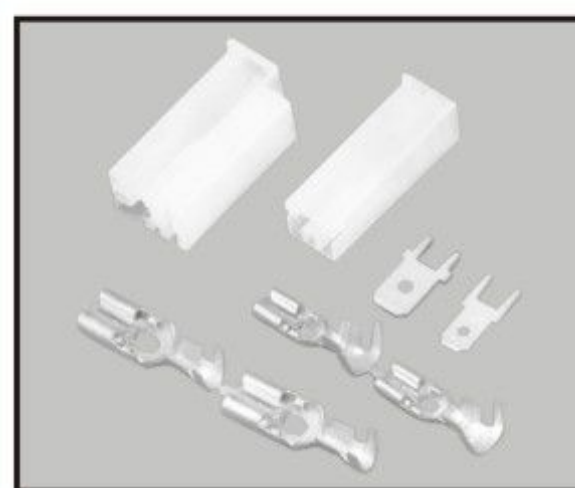

(35196)微波炉系列

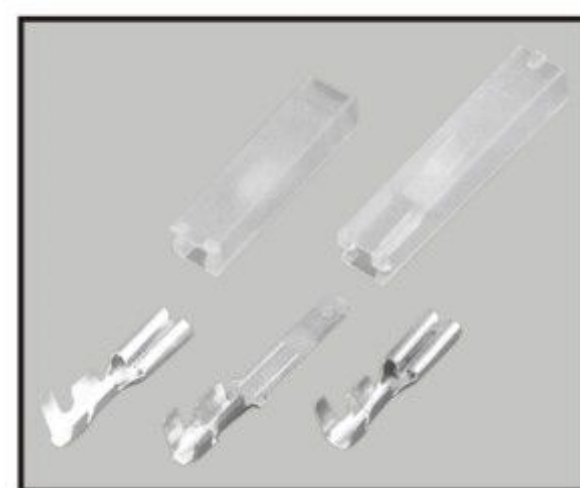

(2.8直播) 硬护套系列



(4.8直播) 硬护套系列



自锁式尼龙带系列

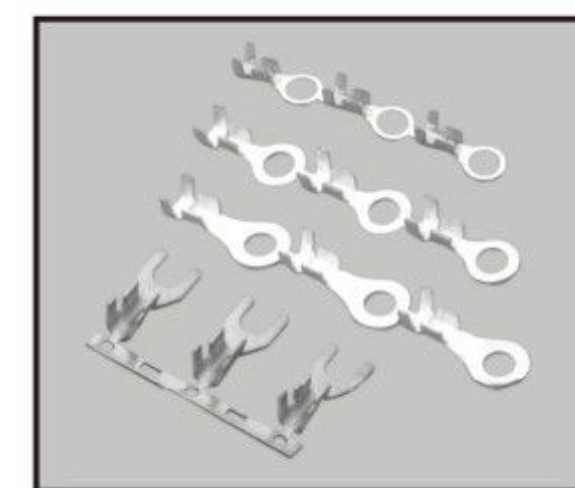

端子系列

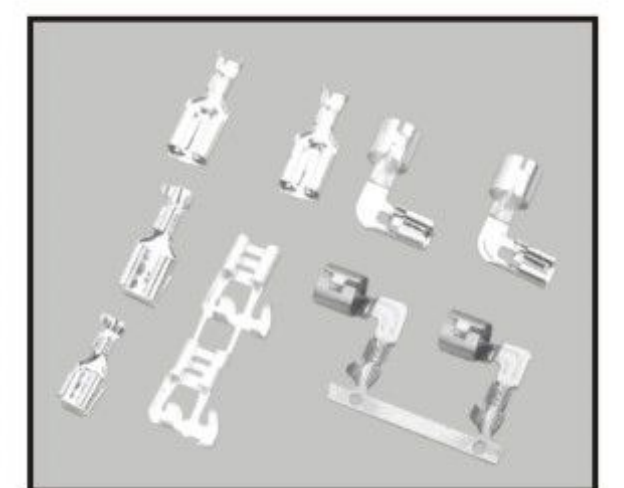

端子系列

JPG 转 PDF 转换器 - 未注册版

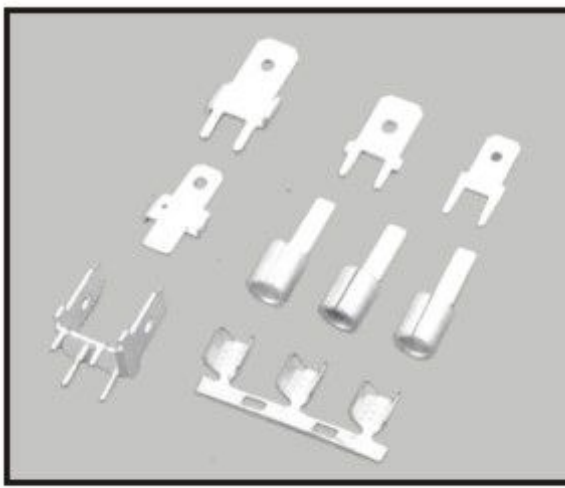

端子系列

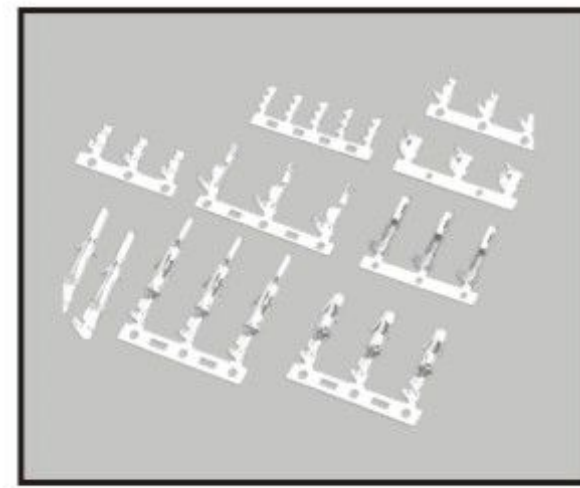

端子系列

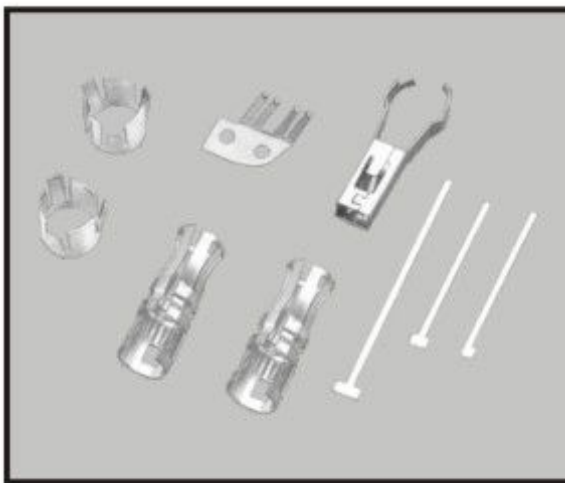

端子系列

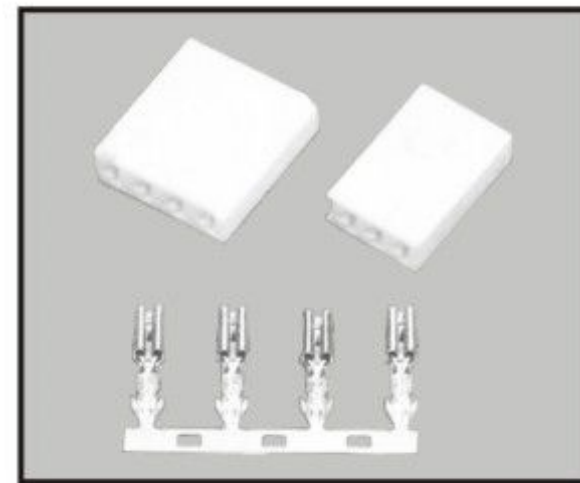

28002(4.1/5.0mm)

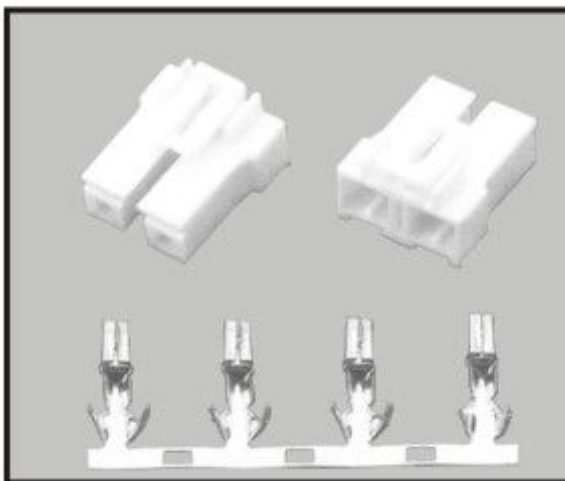

80005(8.0mm)

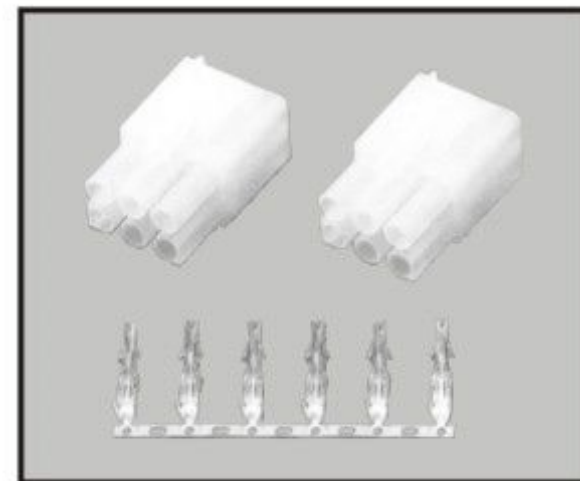

62005(6.2mm)

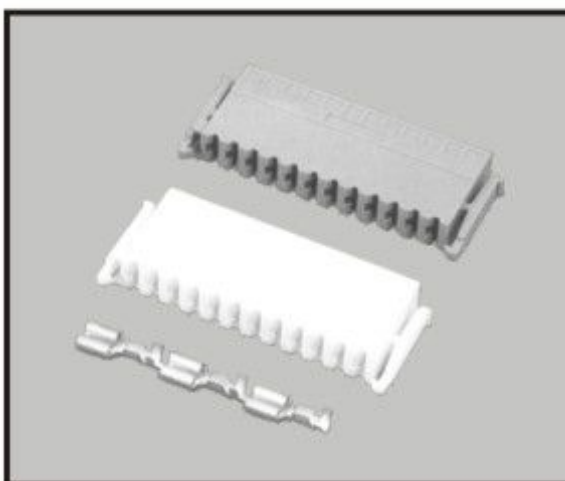

50005(5.0mm)

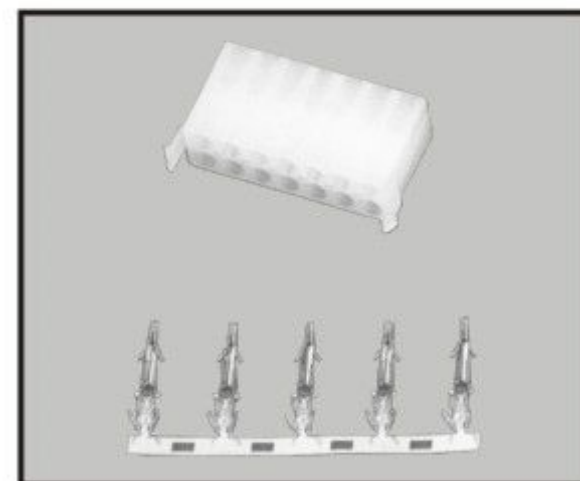

42010(4.2mm)

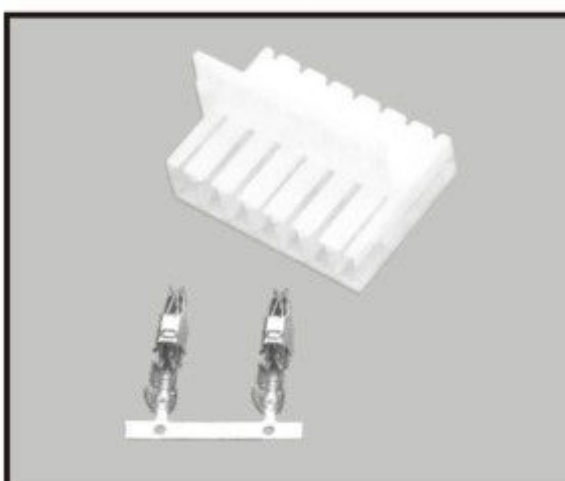

928343-7(5.0mm)



AX-DR12-2P

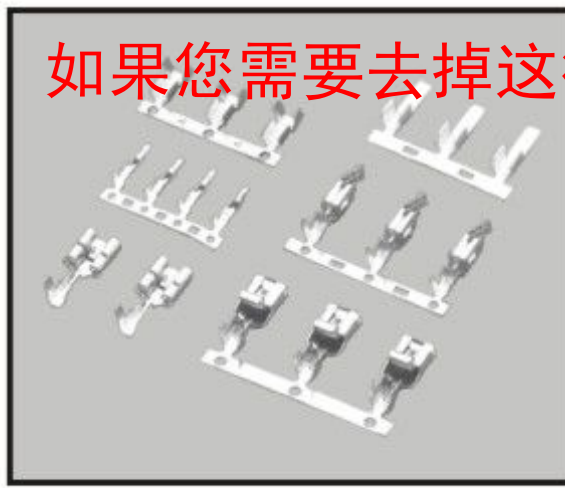

端子系列

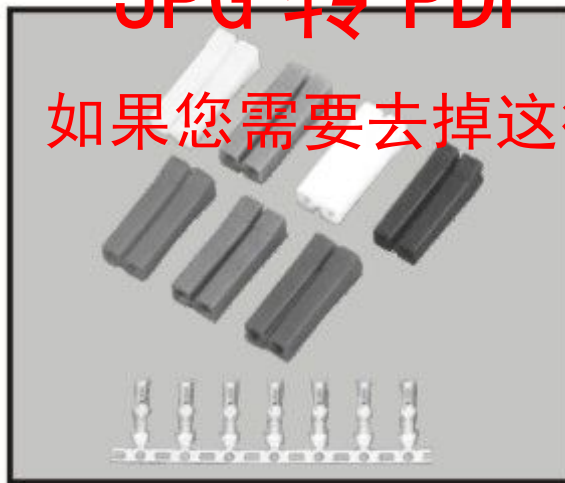

60010(6.0mm)



38000(3.8mm)



VLP-03V(6.2mm)



QH(5.0mm)

如果您需要去掉这行字，请注册 JPG 转 PDF 转换器

JPG 转 PDF 转换器 - 未注册版

如果您需要去掉这行字，请注册 JPG 转 PDF 转换器

JPG 转 PDF 转换器 - 未注册版

如果您需要去掉这行字，请注册 JPG 转 PDF 转换器

JPG 转 PDF 转换器 - 未注册版

如果您需要去掉这行字，请注册 JPG 转 PDF 转换器



洗衣机连接器



空调电器线组件

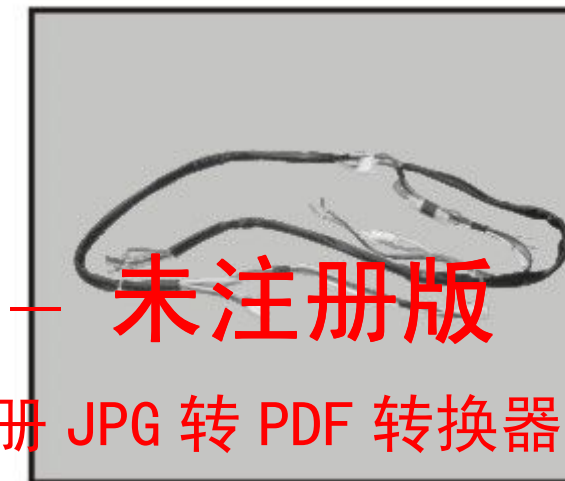

条形连接器



条形连接器



条形连接器



电脑显示器连接线组件



空调电器线组件

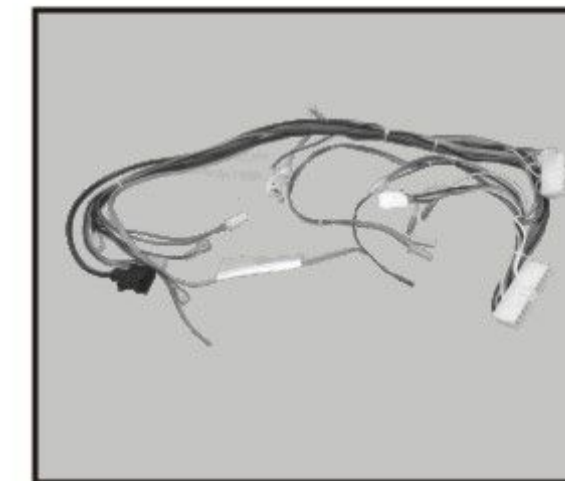

条形连接器

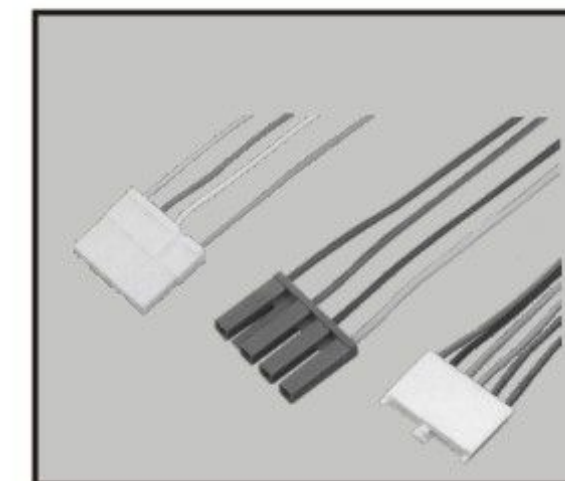

条形连接器

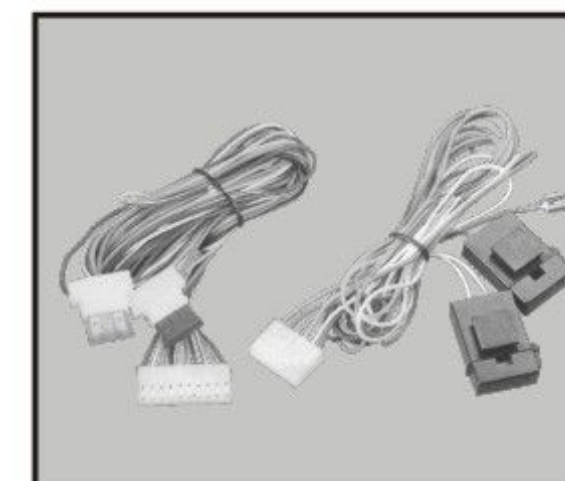

保险丝管连接口

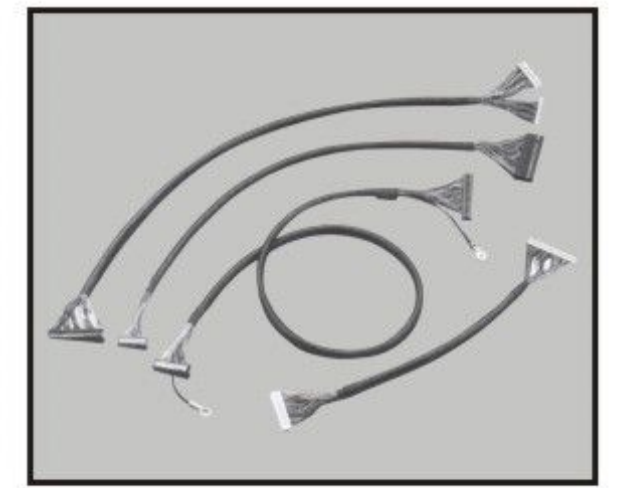

电脑显示器连接线组件

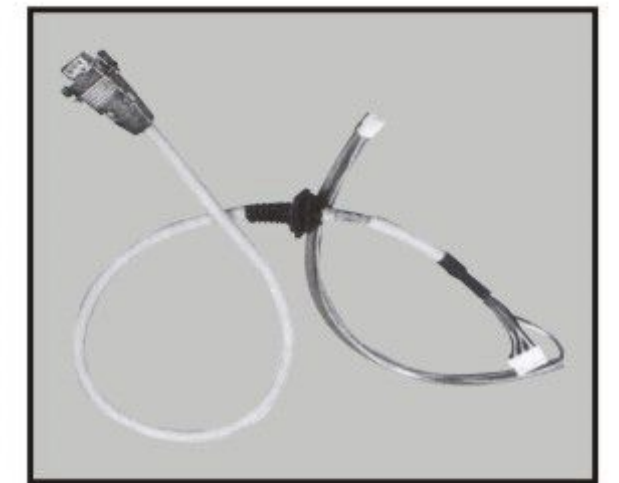

电脑线束组件

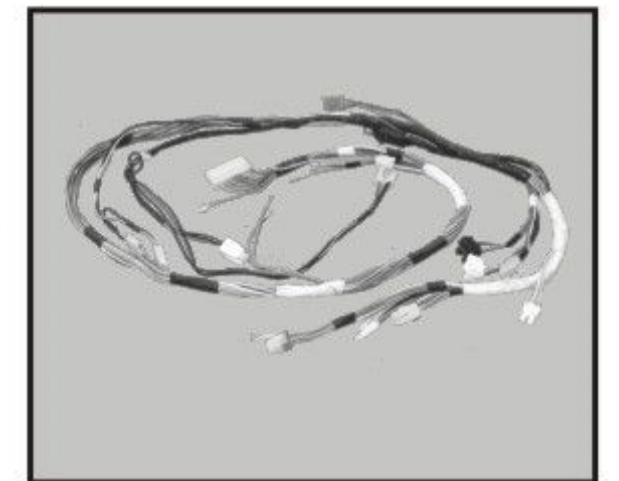

条形连接器

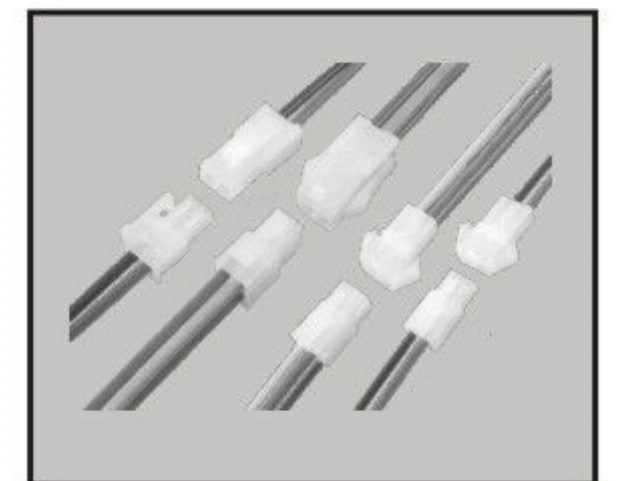

条形连接器

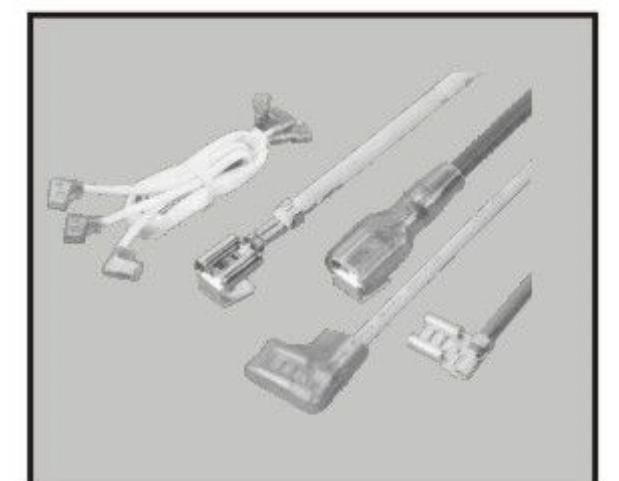

车用连接器

JPG 转 PDF 转换器 – 未注册版

如果您需要去掉这行字，请注册 JPG 转 PDF 转换器

连接器配件图

Connector Component

HA050A
主要技术特性: Main Specifications
间距 Pitch: 0.5mm
线数 Lines: 51
适合电线范围 Applicable wire range: AWG36#-30#
环境温度 Environment temperature: -40℃~+80℃
额定电压 Rate voltage: 20V AC, DC
额定电流 Rate current: 0.8A AC, DC
接触电阻 Contact resistance: $\leq 40m\Omega$
绝缘电阻 Insulation resistance: $\geq 100m\Omega$

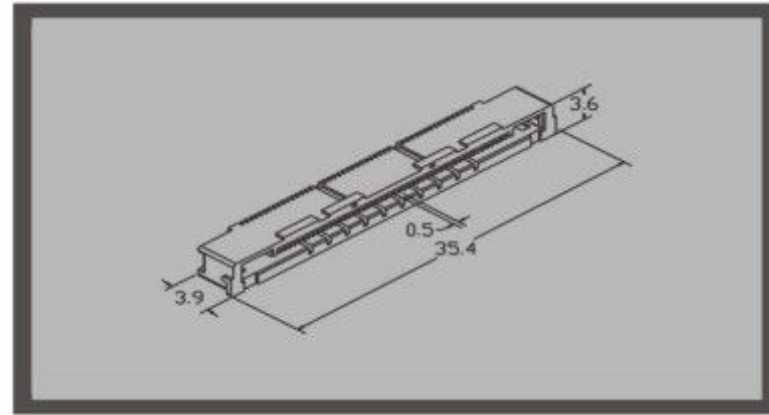

HAP050A-51

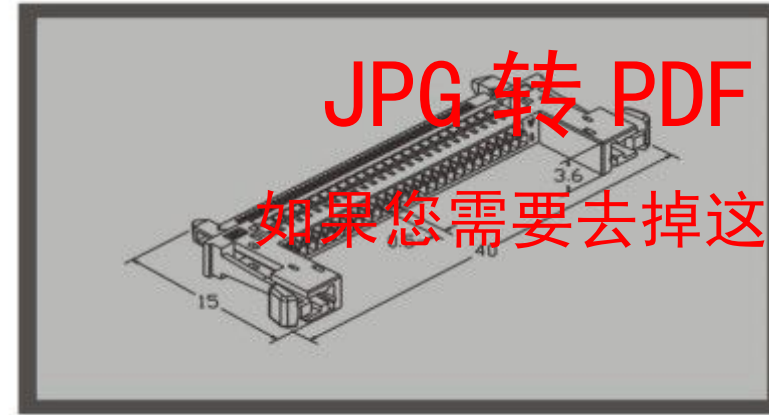

HAY050A-51

HA100A(SH)
主要技术特性: Main Specifications
间距 Pitch: 1.0mm
线数 Lines: 2-40
适合电线范围 Applicable wire range: AWG32#-28#
环境温度 Environment temperature: -25℃~+85℃
额定电压 Rate voltage: 50V AC, DC
额定电流 Rate current: 1.0A AC, DC
接触电阻 Contact resistance: $\leq 20m\Omega$
绝缘电阻 Insulation resistance: $\geq 100m\Omega$
耐压 Voltage resisting: AC250V.1min

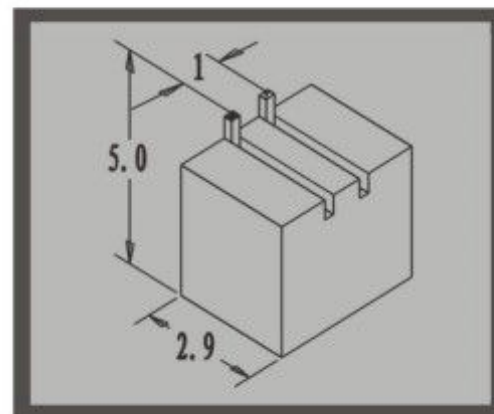

HAA100A-N

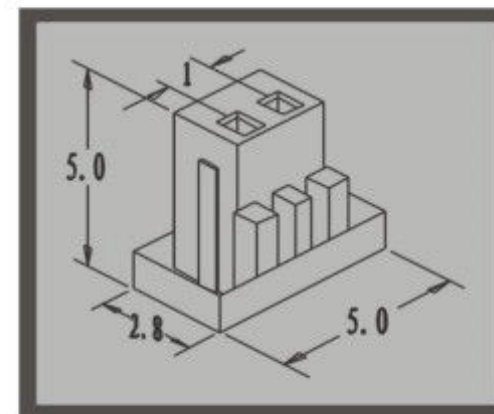

HAY100A-N

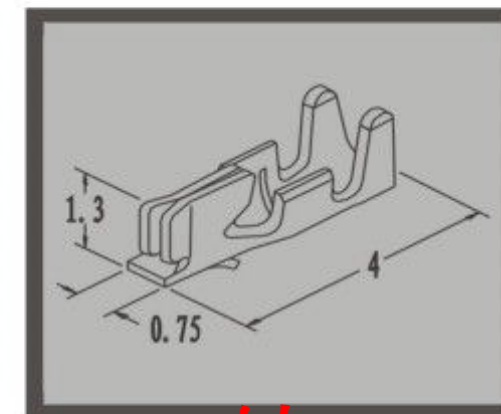

HAS100A-PT

HA100B(FWB-3.0FH-1.0)
主要技术特性: Main Specifications
间距 Pitch: 1.0mm
线数 Lines: 2-30
适合电线范围 Applicable wire range: AWG32#-28#
环境温度 Environment temperature: -25℃~+85℃
额定电压 Rate voltage: 50V AC, DC
额定电流 Rate current: 1.0A AC, DC
接触电阻 Contact resistance: $\leq 20m\Omega$
绝缘电阻 Insulation resistance: $\geq 100m\Omega$
耐压 Voltage resisting: AC250V.1min

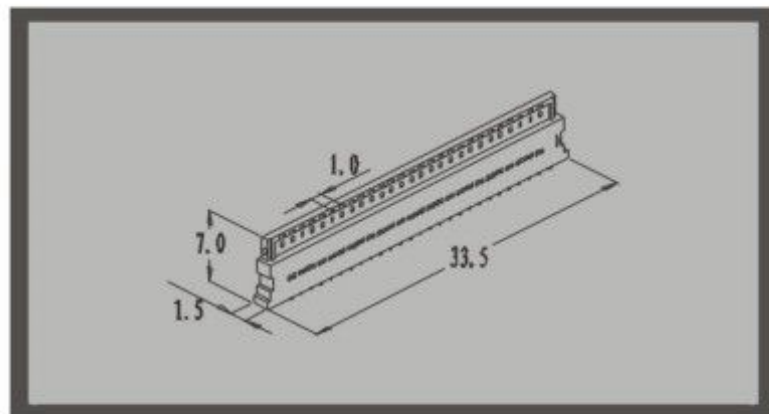

HAY100B-30

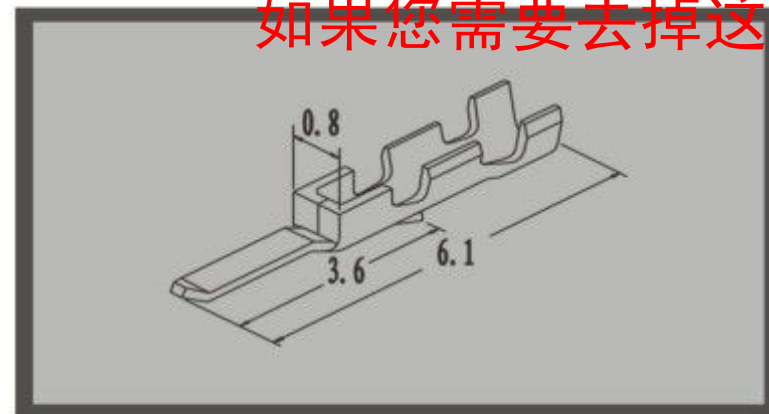

HAS100B-PT

HA100C
主要技术特性: Main Specifications
间距 Pitch: 1.0mm
线数 Lines: 2-30
适合电线范围 Applicable wire range: AWG32#-28#
环境温度 Environment temperature: -25℃~+85℃
额定电压 Rate voltage: 50V AC, DC
额定电流 Rate current: 1.0A AC, DC
接触电阻 Contact resistance: $\leq 20m\Omega$
绝缘电阻 Insulation resistance: $\geq 100m\Omega$
耐压 Voltage resisting: AC250V.1min

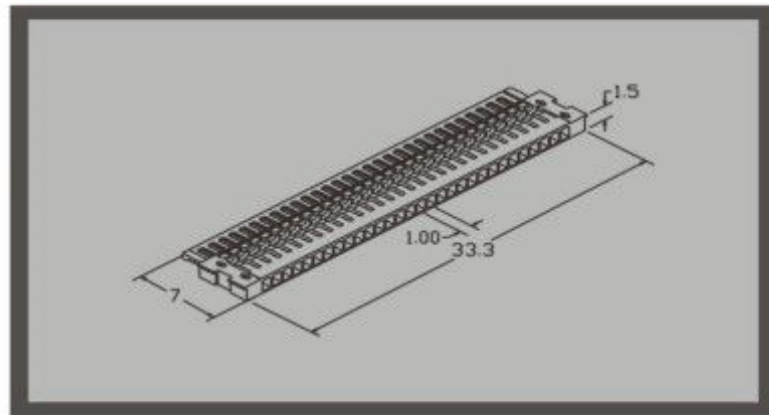

HAY100C-30Y

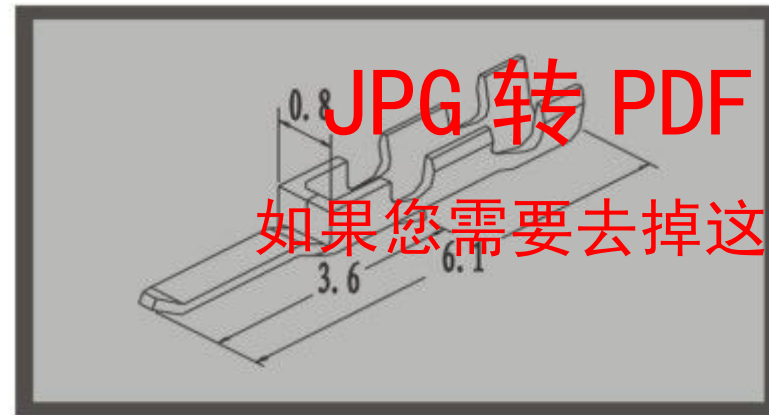

HAS100C-PT

HA100D
主要技术特性: Main Specifications
间距 Pitch: 1.0mm
线数 Lines: 2-30
适合电线范围 Applicable wire range: AWG32#-28#
环境温度 Environment temperature: -25℃~+85℃
额定电压 Rate voltage: 50V AC, DC
额定电流 Rate current: 1.0A AC, DC
接触电阻 Contact resistance: $\leq 20m\Omega$
绝缘电阻 Insulation resistance: $\geq 100m\Omega$
耐压 Voltage resisting: AC250V.1min

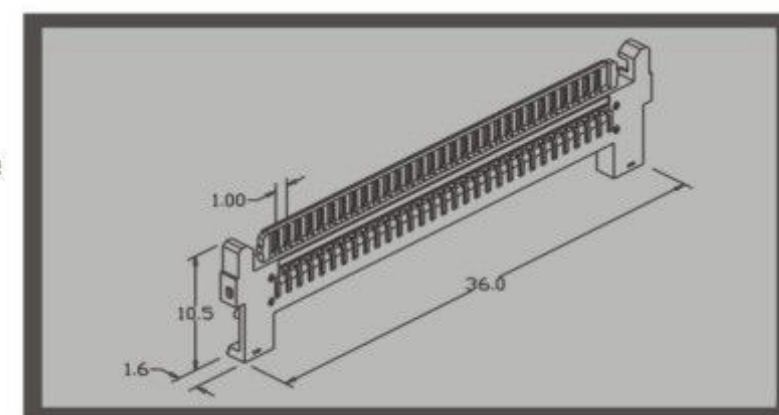

HAY100D-30

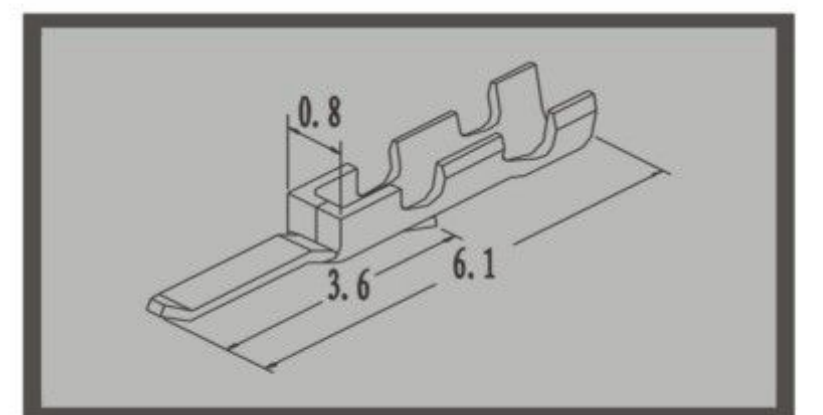

HAS100D-PT/FWB-TMPH

HA100E
主要技术特性: Main Specifications
间距 Pitch: 1.0mm
线数 Lines: 2-30
适合电线范围 Applicable wire range: AWG32#-28#
环境温度 Environment temperature: -25℃~+85℃
额定电压 Rate voltage: 50V AC, DC
额定电流 Rate current: 1.0A AC, DC
接触电阻 Contact resistance: $\leq 20m\Omega$
绝缘电阻 Insulation resistance: $\geq 100m\Omega$
耐压 Voltage resisting: AC250V.1min

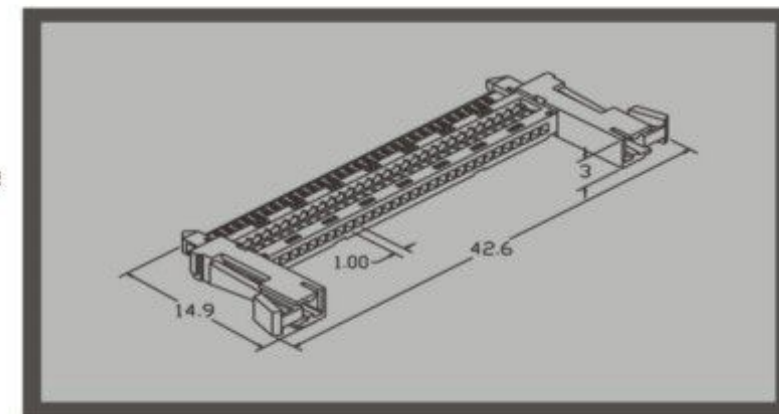

HAY100E-30

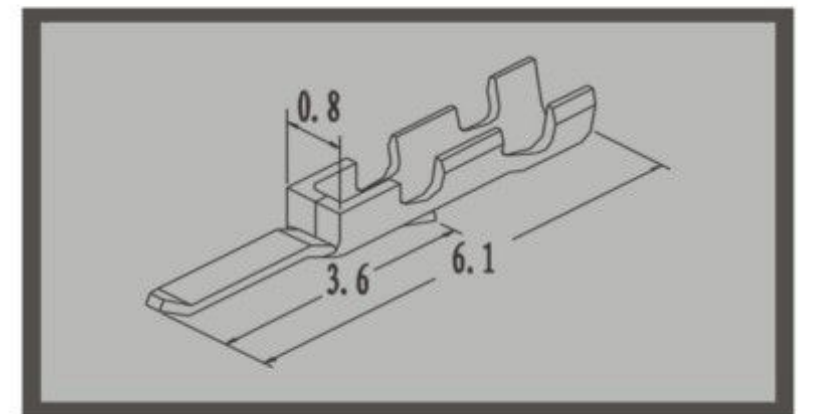

HAS100B-PT/FWB-TMPH

HA100F
主要技术特性: Main Specifications
间距 Pitch: 1.0mm
线数 Lines: 2-30
适合电线范围 Applicable wire range: AWG32#-28#
环境温度 Environment temperature: -25℃~+85℃
额定电压 Rate voltage: 50V AC, DC
额定电流 Rate current: 1.0A AC, DC
接触电阻 Contact resistance: $\leq 20m\Omega$
绝缘电阻 Insulation resistance: $\geq 100m\Omega$
耐压 Voltage resisting: AC250V.1min

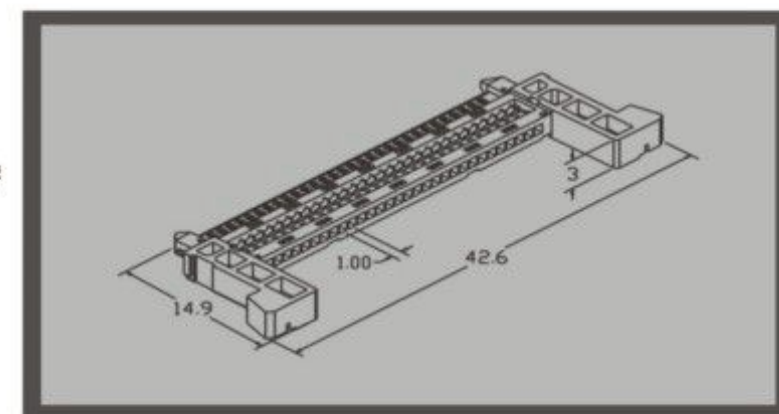

HAY100F-30

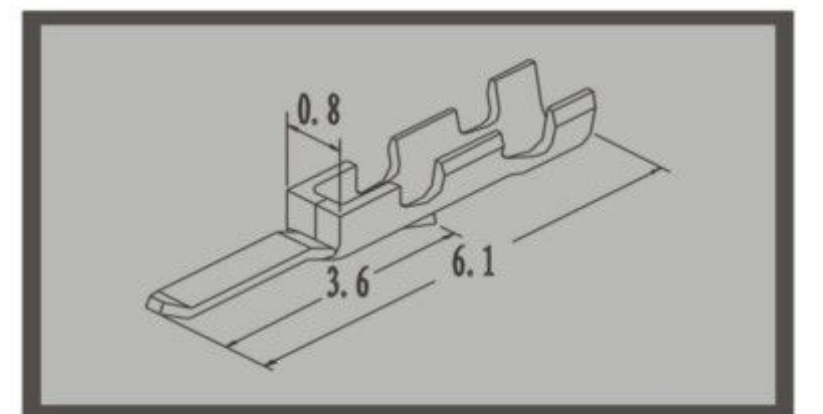

HAS100B-PT/FWB-TMPH

HA125A(51021)
主要技术特性: Main Specifications
间距 Pitch: 2.5mm
线数 Lines: 2-30
适合电线范围 Applicable wire range: AWG32#-28#
环境温度 Environment temperature: -25℃~+85℃
额定电压 Rate voltage: 125V AC, DC
额定电流 Rate current: 1.0A AC, DC
接触电阻 Contact resistance: $\leq 20m\Omega$
绝缘电阻 Insulation resistance: $\geq 100m\Omega$
耐压 Voltage resisting: AC250V.1min

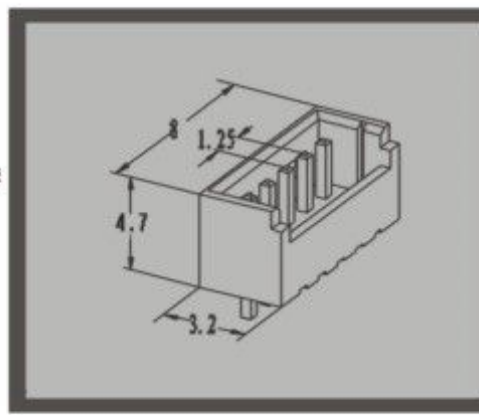

HAA125A-nA/53047-nA

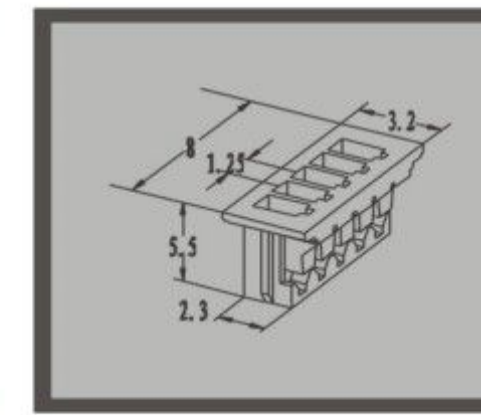

HAY125A-nY

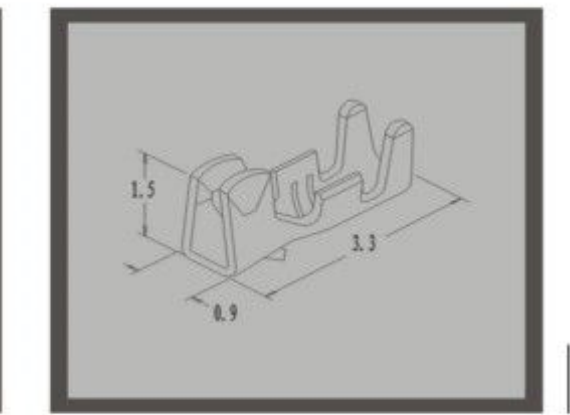

HAS125A-PT

JPG 转 PDF 转换器 – 未注册版

如果您需要去掉这行字，请注册 JPG 转 PDF 转换器

连接器配件图

Connector Component

HA125B(镀金JAE1.25)
主要技术特性: Main Specifications
间距 Pitch: 1.25mm
线数 Lines: 2-16
适合电线范围 Applicable wire range: AWG32#-28#
环境温度 Environment temperature: -25℃~+85℃
额定电压 Rate voltage: 125V AC, DC
额定电流 Rate current: 1.0A AC, DC
接触电阻 Contact resistance: $\leq 20m\Omega$
绝缘电阻 Insulation resistance: $\geq 100m\Omega$
耐压 Voltage resisting: AC250V.1min

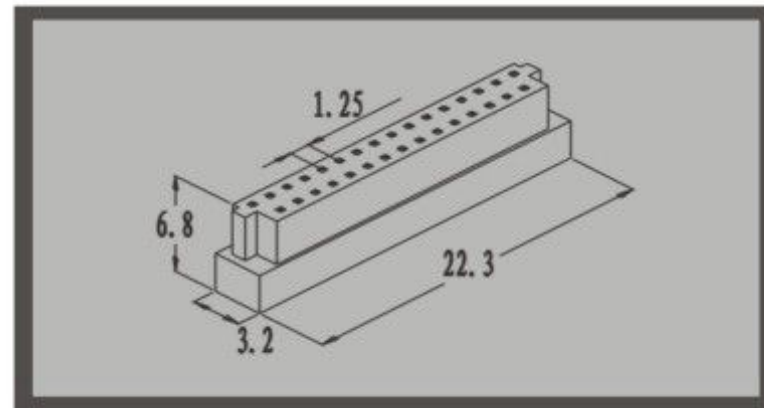

HAY125B-n

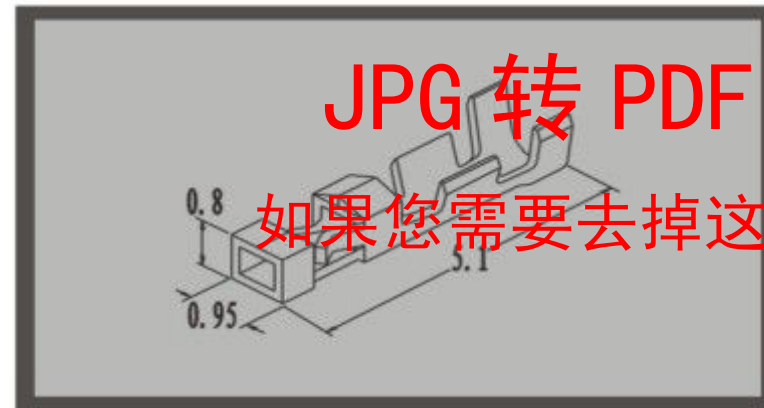

HAS125B-PT

HA125C(DF13)
主要技术特性: Main Specifications
间距 Pitch: 1.25mm
线数 Lines: 2-30
适合电线范围 Applicable wire range: AWG32#-28#
环境温度 Environment temperature: -25℃~+85℃
额定电压 Rate voltage: 125V AC, DC
额定电流 Rate current: 1.0A AC, DC
接触电阻 Contact resistance: $\leq 20m\Omega$
绝缘电阻 Insulation resistance: $\geq 100m\Omega$
耐压 Voltage resisting: AC250V.1min

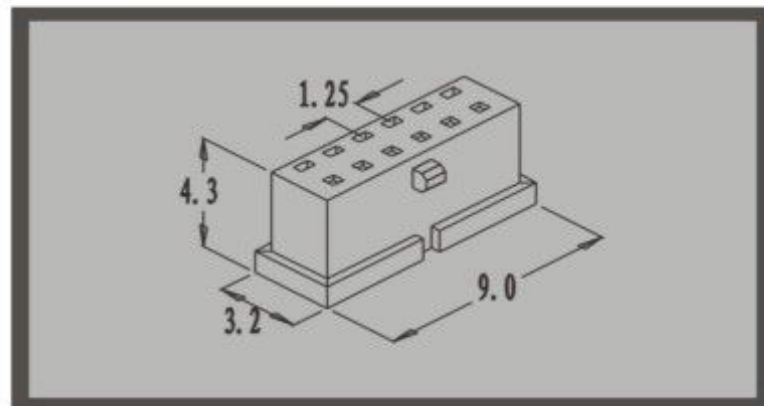

HAY125C-1/DF13-nY

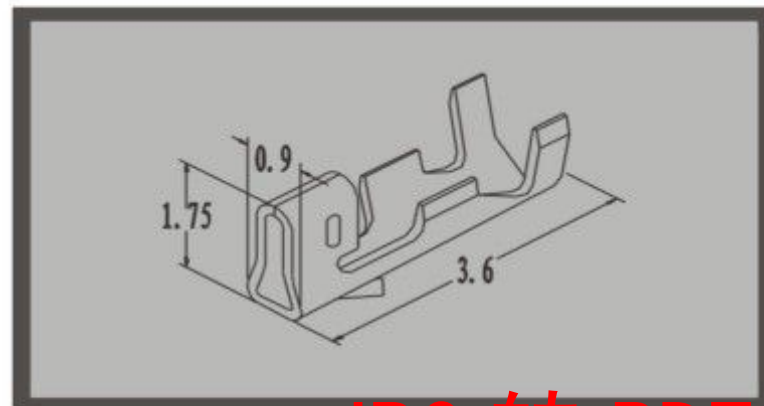

HAS125C-1/DF13-PT

HA125D(DF14)
主要技术特性: Main Specifications
间距 Pitch: 1.25mm
线数 Lines: 2-60
适合电线范围 Applicable wire range: AWG32#-28#
环境温度 Environment temperature: -25℃~+85℃
额定电压 Rate voltage: 125V AC, DC
额定电流 Rate current: 1.0A AC, DC
接触电阻 Contact resistance: $\leq 20m\Omega$
绝缘电阻 Insulation resistance: $\geq 100m\Omega$
耐压 Voltage resisting: AC250V.1min

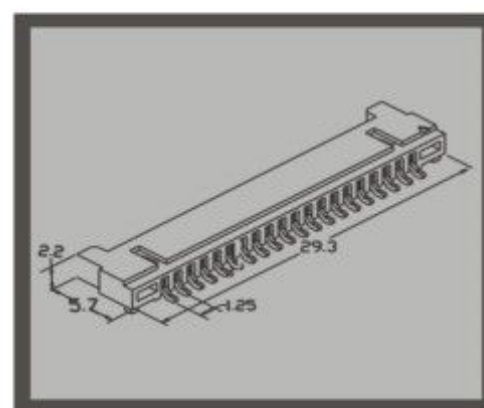

HAA125D-n

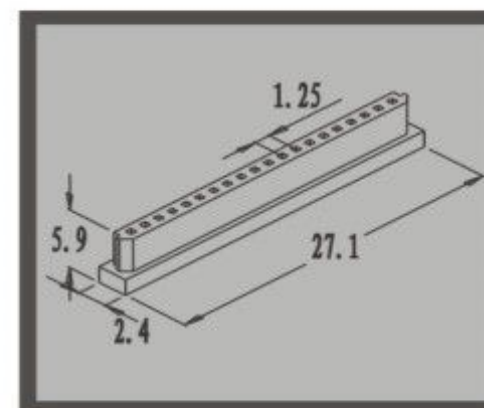

HAY125D-n

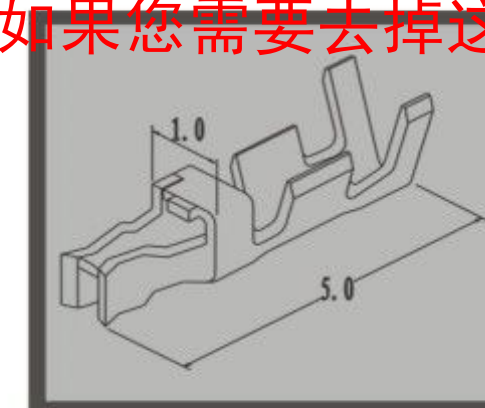

HAS125D-PT

HA150A(ZH)
主要技术特性: Main Specifications
间距 Pitch: 1.5mm
线数 Lines: 2-30
适合电线范围 Applicable wire range: AWG32#-28#
环境温度 Environment temperature: -25℃~+85℃
额定电压 Rate voltage: 150V AC, DC
额定电流 Rate current: 1.0A AC, DC
接触电阻 Contact resistance: $\leq 20m\Omega$
绝缘电阻 Insulation resistance: $\geq 500m\Omega$
耐压 Voltage resisting: AC250V.1min

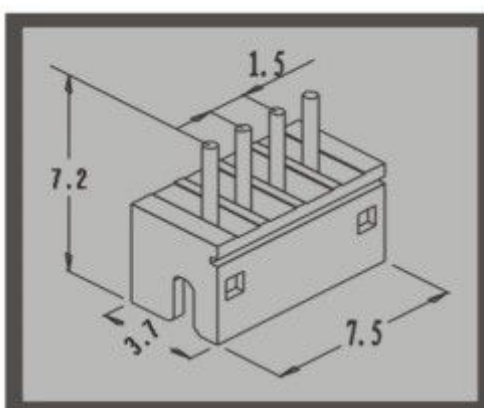

HAA150A-n

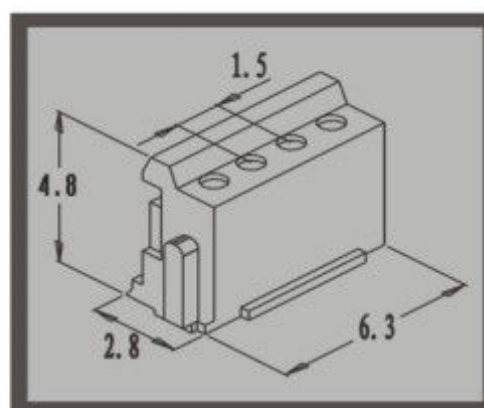

HAY150A-n

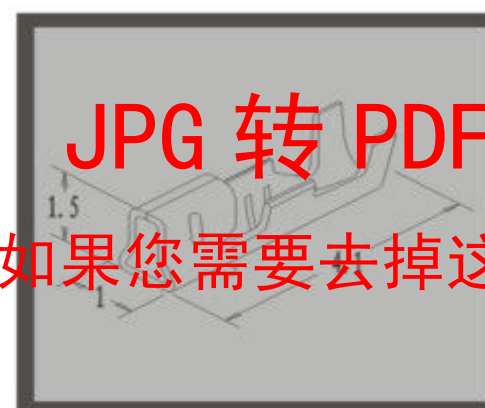

HAS150A-PT

HA200A(PH)
主要技术特性: Main Specifications
间距 Pitch: 2.0mm
线数 Lines: 2-16
适合电线范围 Applicable wire range: AWG32#-28#
环境温度 Environment temperature: -25℃~+85℃
额定电压 Rate voltage: 100V AC, DC
额定电流 Rate current: 2.0A AC, DC
接触电阻 Contact resistance: $\leq 10m\Omega$
绝缘电阻 Insulation resistance: $\geq 1000m\Omega$
耐压 Voltage resisting: AC250V.1min

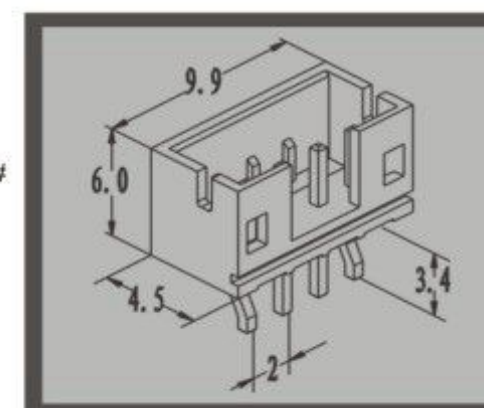

HAA200A-n

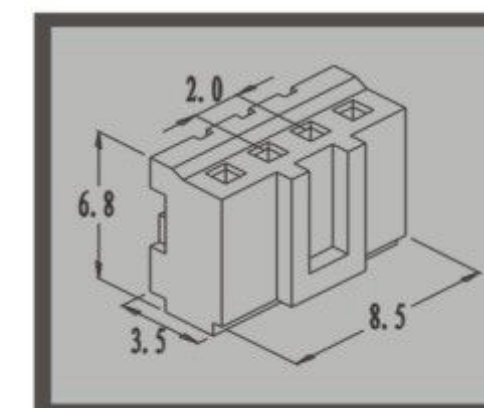

HAY200A-n

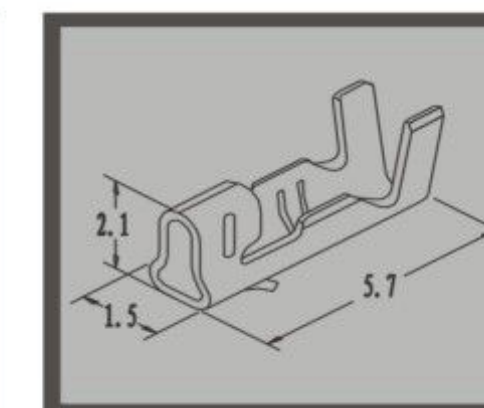

HAS200A-PT

HA200B(SAN)
主要技术特性: Main Specifications
间距 Pitch: 2.0mm
线数 Lines: 2-30
适合电线范围 Applicable wire range: AWG32#-28#
环境温度 Environment temperature: -25℃~+85℃
额定电压 Rate voltage: 250V AC, DC
额定电流 Rate current: 2.0A AC, DC
绝缘电阻 Insulation resistance: $\geq 1000m\Omega$
耐压 Voltage resisting: AC800V.1min

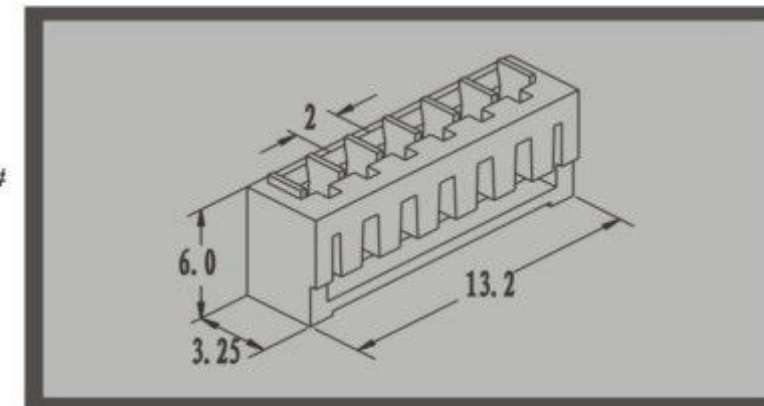

HAY200B-n/SAN-nY

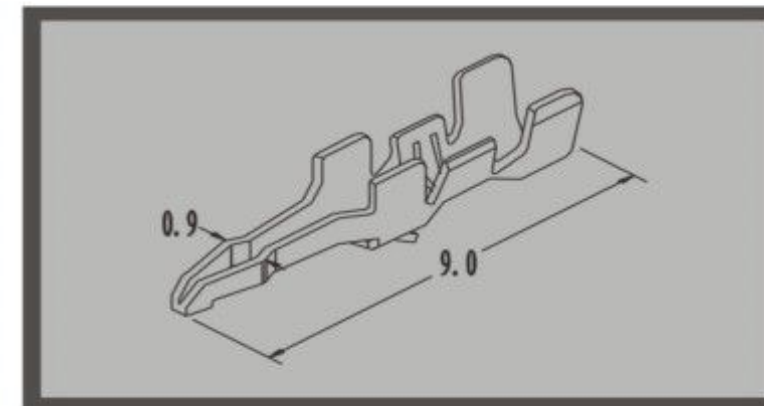

HAS200B-PT/SAN-PT

HA200C(JC20)
主要技术特性: Main Specifications
间距 Pitch: 2.0mm
线数 Lines: 2-30
适合电线范围 Applicable wire range: AWG32#-28#
环境温度 Environment temperature: -25℃~+85℃
额定电压 Rate voltage: 250V AC, DC
额定电流 Rate current: 2.0A AC, DC
绝缘电阻 Insulation resistance: $\geq 1000m\Omega$
耐压 Voltage resisting: AC800V.1min

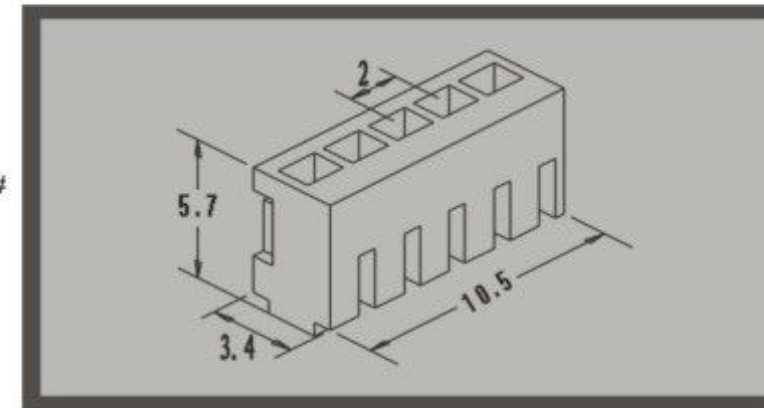

HAY200C-n/JC20-nY

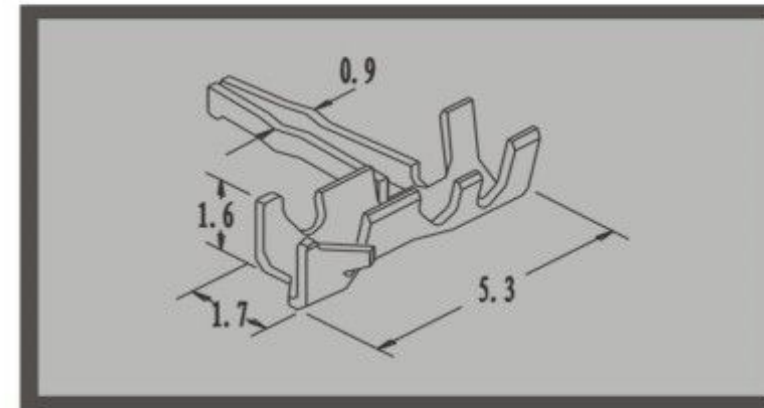

HAS100C-PT/JC20-PT

HA200D(HY)
主要技术特性: Main Specifications
间距 Pitch: 2.0mm
线数 Lines: 2-15
适合电线范围 Applicable wire range: AWG30#-24#
环境温度 Environment temperature: -25℃~+85℃
额定电压 Rate voltage: 250V AC, DC
额定电流 Rate current: 2.0A AC, DC
接触电阻 Contact resistance: $\leq 10m\Omega$
绝缘电阻 Insulation resistance: $\geq 1000m\Omega$
耐压 Voltage resisting: AC800V.1min

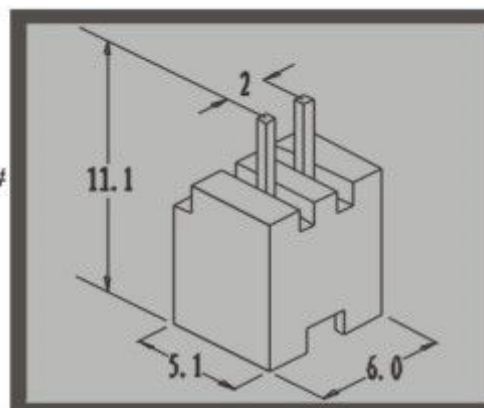

HAA200D-n/HY-n4

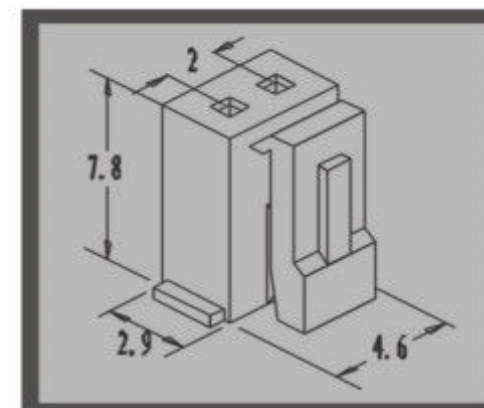

HAY200D-N/HY-nY

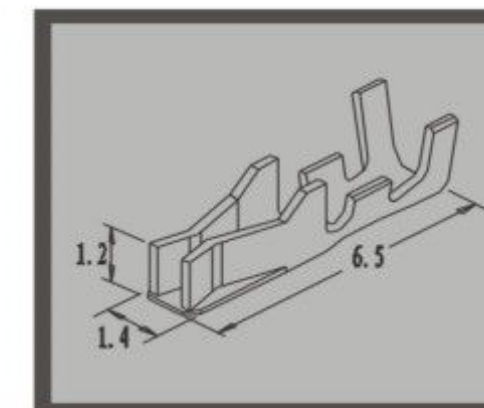

HAS200D-PT/HY-PT

连接器配件图

Connector Component