

WIDE TEMPERATURE RANGE, HEIGHT 7(9)MM

7(9)MM 高，寬溫品

- Super miniature series with 7(9)mm height
7(9)mm 高，超小型系列
- High performance and excellent temperature characteristics
高性能和卓越的温度特性
- Load life of 1000 hours at 105°C
在 105°C 環境中負荷壽命 1000 小時
- Comply with the RoHS directive
符合 RoHS 指令

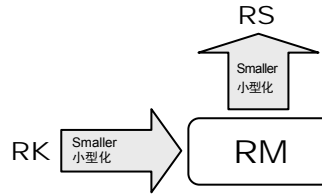

□ SPECIFICATIONS 特性表

Items 項目	Characteristics 主要特性															
Operation Temperature Range 使用溫度範圍	-40 ~ +105°C															
Voltage Range 額定工作電壓範圍	4 ~ 63V															
Capacitance Range 靜電容量範圍	0.1 ~ 1000μF															
Capacitance Tolerance 靜電容量允許偏差	±20% at 120Hz, 20°C															
Leakage Current 漏電流	Leakage current = 0.01CV or 3μA, whichever is greater (after 2 minutes application of rated voltage) 漏電流 = 0.01CV 或 3μA，取較大值（施加額定工作電壓 2 分鐘後）															
Dissipation Factor (tan δ) 損耗角正切	When nominal capacitance is over 1000μF, tan δ shall be added 0.02 to the listed value with increase of every 1000μF. 當標稱靜電容量大於 1000μF，其標稱靜電容量每增加 1000μF，損耗角正切增加 0.02。 Measurement frequency 測試頻率: 120Hz, Temperature 溫度: 20°C															
Stability at Low Temperature 低溫特性	Measurement frequency 測試頻率: 120Hz															
	<table border="1"> <thead> <tr> <th>Rated Voltage (V) 額定工作電壓</th> <th>4</th> <th>6.3</th> <th>10</th> <th>16</th> <th>25</th> <th>35</th> <th>50, 63</th> </tr> </thead> <tbody> <tr> <td>tan δ (max.) 最大損耗角正切</td> <td>0.35</td> <td>0.24</td> <td>0.20</td> <td>0.16</td> <td>0.14</td> <td>0.12</td> <td>0.10</td> </tr> </tbody> </table>	Rated Voltage (V) 額定工作電壓	4	6.3	10	16	25	35	50, 63	tan δ (max.) 最大損耗角正切	0.35	0.24	0.20	0.16	0.14	0.12
Rated Voltage (V) 額定工作電壓	4	6.3	10	16	25	35	50, 63									
tan δ (max.) 最大損耗角正切	0.35	0.24	0.20	0.16	0.14	0.12	0.10									
Load Life 高溫負荷特性	After 1000 hours application of the rated voltage at 105°C, they meet the characteristics listed below. 在 105°C 環境中施加額定工作電壓 1000 小時後，電容器的特性符合下表的要求。															
	<table border="1"> <tbody> <tr> <td>Capacitance Change 靜電容量變化率</td> <td>Within ±20% of initial measured value 初始值的 ±20% 以內</td> </tr> <tr> <td>Dissipation Factor 損耗角正切</td> <td>≤ 200% of initial specified value 不大於規範值的 200%</td> </tr> <tr> <td>Leakage Current 漏電流</td> <td>≤ initial specified value 不大於規範值</td> </tr> </tbody> </table>	Capacitance Change 靜電容量變化率	Within ±20% of initial measured value 初始值的 ±20% 以內	Dissipation Factor 損耗角正切	≤ 200% of initial specified value 不大於規範值的 200%	Leakage Current 漏電流	≤ initial specified value 不大於規範值									
Capacitance Change 靜電容量變化率	Within ±20% of initial measured value 初始值的 ±20% 以內															
Dissipation Factor 損耗角正切	≤ 200% of initial specified value 不大於規範值的 200%															
Leakage Current 漏電流	≤ initial specified value 不大於規範值															
Shelf Life 高溫貯存特性	After leaving capacitors under no load at 105°C for 1000 hours, they meet the specified value for load life characteristics listed above. 在 105°C 環境中無負荷放置 1000 小時後，電容器的特性符合高溫負荷特性中所列的規定值。															
Marking 標識	Printed with white colour on black sleeve (PVC) or printed with white colour on green sleeve (PET). 黑色膠管白字印刷 (PVC) 或綠色膠管白字印刷 (PET)。															

□ DRAWING (Unit: mm) 外形圖

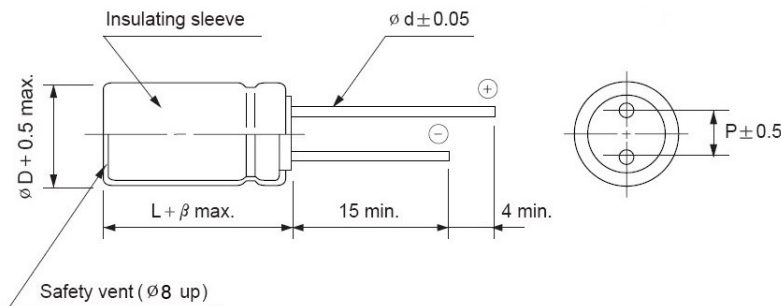

ØD	4	5	6.3	8
P	1.5	2.0	2.5	3.5
Ød	0.45			0.50
β	1.0			

Note: All design and specifications are for reference only and is subject to change without prior notice. If any doubt about safety for your application, please contact us immediately for technical assistance before purchase.

注：以上所提供的設計及特性參數僅供參考，任何修改不作預先通知。如果在使用上有疑問，請在採購前與我們聯繫，以便提供技術上的協助。

□ DIMENSIONS & MAXIMUM PERMISSIBLE RIPPLE CURRENT 規格尺寸及最大允許紋波電流

μF	WV Code 代碼	4		6.3		10		16		25		35		50		63		
		0G		0J		1A		1C		1E		1V		1H		1J		
0.1	0R1														4 x 7	1	4 x 7	2.4
0.22	R22														4 x 7	2.3	4 x 7	3.2
0.33	R33														4 x 7	3.5	4 x 7	4
0.47	R47														4 x 7	5	4 x 7	6
0.68	R68														4 x 7	10	4 x 7	11
1	010														4 x 7	16	4 x 7	18
2.2	2R2														4 x 7	24	4 x 7	26
3.3	3R3														4 x 7	29	4 x 7	30
4.7	4R7														4 x 7	32	5 x 7	33
6.8	6R8											4 x 7	28	4 x 7	34	5 x 7	35	
10	100							4 x 7	28	4 x 7	28	4 x 7	32	4 x 7 (5 x 7)	34 (44)	6.3 x 7	45	
22	220					4 x 7	36	4 x 7	45	4 x 7 (5 x 7)	48 (50)	5 x 7	53	6.3 x 7	65	6.3 x 7	68	
33	330					4 x 7	45	4 x 7	48	5 x 7	52	5 x 7	67	6.3 x 7	100	8 x 7	110	
47	470			4 x 7	45	4 x 7	48	4 x 7 (5 x 7)	70 (80)	5 x 7 (6.3 x 7)	80 (85)	6.3 x 7	90	8 x 7	140			
68	680			4 x 7	45	5 x 7	80	5 x 7	85	6.3 x 7	105	6.3 x 7	120					
100	101	4 x 7	28	4 x 7 (5 x 7)	55 (85)	5 x 7	90	5 x 7 (6.3 x 7)	105 (125)	6.3 x 7 (8 x 7) (8 x 9)	125 (135) (170)	8 x 7	165					
220	221	5 x 7	65	6.3 x 7	110	6.3 x 7	125	6.3 x 7 (8 x 7) (8 x 9)	138 (145) (168)	8 x 9	179							
330	331	6.3 x 7	120	6.3 x 7	130	8 x 7 (8 x 9)	150 (170)	8 x 7	182									
470	471	6.3 x 7	150	6.3 x 7 (8 x 7) (8 x 9)	140 (160) (180)	8 x 9	190	8 x 9	200									
1000	102	8 x 9	215														Case size 尺寸	Ripple current 紋波電流

Case size ∅D×L(mm), ripple current (mA rms) at 105°C 120Hz • 尺寸∅D×L(mm), 紋波電流(mA rms)於 105°C 120Hz

- Please refer to page 16, 18 about the formed or taped product spec. 編帶與引線成型標準請參閱第 16, 18 頁。
- Please refer to page 17 for the minimum package quantity. 最小包裝數量請參閱第 17 頁。

Note: All design and specifications are for reference only and is subject to change without prior notice. If any doubt about safety for your application, please contact us immediately for technical assistance before purchase.

注：以上所提供的設計及特性參數僅供參考，任何修改不作預先通知。如果在使用上有疑問，請在採購前與我們聯繫，以便提供技術上的協助。