

# **INNOLUX DISPLAY CORPORATION**

## **LCD MODULE**

# **SPECIFICATION**

**Customer:** \_\_\_\_\_  
**Model Name:** AT050TN22  
**SPEC NO.:** A050-22-TT-01  
**Date:** 2007/10/29  
**Version:** 01

- Preliminary Specification  
 Final Specification

<b>Option</b>
<input checked="" type="checkbox"/> <b>AT050TN22 LCM (PCB)</b>

For Customer's Acceptance

Approved by	Comment

Approved by	Reviewed by	Prepared by
<b>Joe Lin</b>  2007/11/07	<b>James Yu</b>  2007/11/06	<b>Kevin Chen</b>  2007/11/05

**Record of Revision**

Version	Revise Date	Page	Content
Pre-Spec.01	2007/06/04		Initial Release
Final-Spec.01	2007/10/29		The First Final Spec.

# Contents

1. General Specifications.....	1
2. Pin Assignment .....	2
3. Operation Specifications .....	5
3.1. Absolute Maximum Rating .....	5
3.2. Typical Operation Conditions.....	6
3.3. Power Sequence.....	7
3.4. Timing Characteristics.....	8
3.4.1. Timing Conditions.....	8
3.4.2. Timing Diagram.....	10
4. Optical Specification.....	13
5. Reliability Test.....	17
6. General Precautions .....	18
6.1. Safety.....	18
6.2. Handling.....	18
6.3. Static Electricity .....	18
6.4. Storage.....	18
6.5. Cleaning.....	18
7. Mechanical Drawing.....	19
8. Package Drawing.....	20
8.1. Packaging Material Table .....	20
8.2. Packaging Quantity .....	20
8.3. Package Drawing.....	21

# 1. General Specifications

No.	Item	Specification	Remark
1	LCD size	5.0 inch(Diagonal)	
2	Driver element	a-Si TFT active matrix	
3	Resolution	640X(RGB)X480	
4	Display mode	Normally White, Transmissive	
5	Dot pitch	0.0529(W)X0.1587(H) mm	
6	Active area	101.568(W)X76.176(H) mm	
7	Module size	117.65(W)X88.43(H)X5.7(D) mm	Note 1
8	Surface treatment	Anti-Glare	
9	Color arrangement	RGB-stripe	
10	Interface	Digital	
11	Backlight Power consumption	1.500W(Typ.)	Note 2
12	Panel Power consumption	0.660W(Typ.)	Note 3
13	Weight	75g(Typ.)	

Note 1: Refer to Mechanical Drawing.

Note 2: Including LED Driver power consumption.

Note 3: Including T-con Board power consumption.

## 2.Pin Assignment

### TFT LCD Panel Driving Section

Note: FPC connector is used for the module electronics interface. The recommended model is FH12-40S-0.5SH manufactured by HiRose.

Pin No.	Symbol	I/O	Function	Remark
1	V <sub>LED</sub>	P	Power voltage for LED circuit	
2	V <sub>LED</sub>	P	Power voltage for LED circuit	
3	ADJ	I	Adjust the LED brightness with PWM Pulse	Note1,2
4	G <sub>LED</sub>	P	Ground for LED circuit	
5	G <sub>LED</sub>	P	Ground for LED circuit	
6	V <sub>CC</sub>	P	Power voltage for digital circuit	
7	V <sub>CC</sub>	P	Power voltage for digital circuit	
8	MODE	I	DE or HV mode control	Note 3
9	DE	I	Data enable	
10	VS	I	Vsync signal input	
11	HS	I	Hsync signal input	
12	GND	P	Power ground	
13	B5	I	Blue data input (MSB)	
14	B4	I	Blue data input	
15	B3	I	Blue data input	
16	GND	P	Power ground	
17	B2	I	Blue data input	
18	B1	I	Blue data input	
19	B0	I	Blue data input(LSB)	
20	GND	P	Power ground	
21	G5	I	Green data input(MSB)	
22	G4	I	Green data input	
23	G3	I	Green data input	
24	GND	P	Power ground	
25	G2	I	Green data input	

26	G1	I	Green data input	
27	G0	I	Green data input(LSB)	
28	GND	P	Power ground	
29	R5	I	Red data input(MSB)	
30	R4	I	Red data input	
31	R3	I	Red data input	
32	GND	P	Power ground	
33	R2	I	Red data input	
34	R1	I	Red data input	
35	R0	I	Red data input(LSB)	
36	GND	P	Power ground	
37	DCLK	I	Sample clock	
38	GND	P	Power ground	
39	L/R	I	Select left to right scanning direction	Note4,5
40	U/D	I	Select up or down scanning direction	Note4,5

Note: I: input, O: output, P: Power

Note1: Pin.3 is used to adjust brightness.

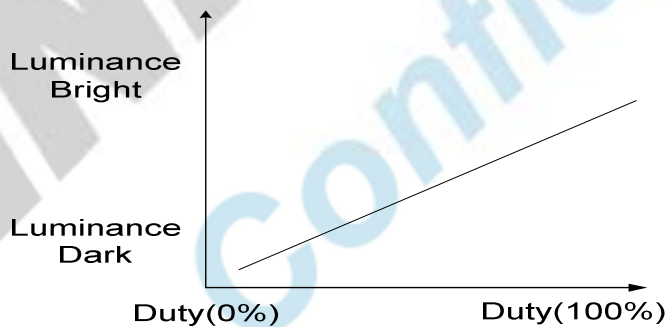

Note 2: ADJ signal=0~3.3V, operation frequency: 100~300Hz

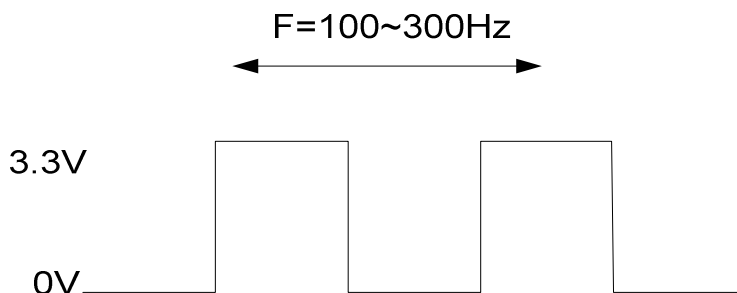

版權屬於群創所有，禁止任何未經授權的使用

The copyright belongs to InnoLux. Any unauthorized use is prohibited.

Note 3: DE Mode, Mode="H", HS floating and VS floating  
 HV Mode, Mode="L" and DE floating

Note4: Selection of scanning mode

Setting of scan control input		Scanning direction
U/D	R/L	
GND	V <sub>CC</sub>	Up to down, left to right
V <sub>CC</sub>	GND	Down to up, right to left
GND	GND	Up to down, right to left
V <sub>CC</sub>	V <sub>CC</sub>	Down to up, left to right

Note 5: Definition of scanning direction.  
 Refer to the figure as below:

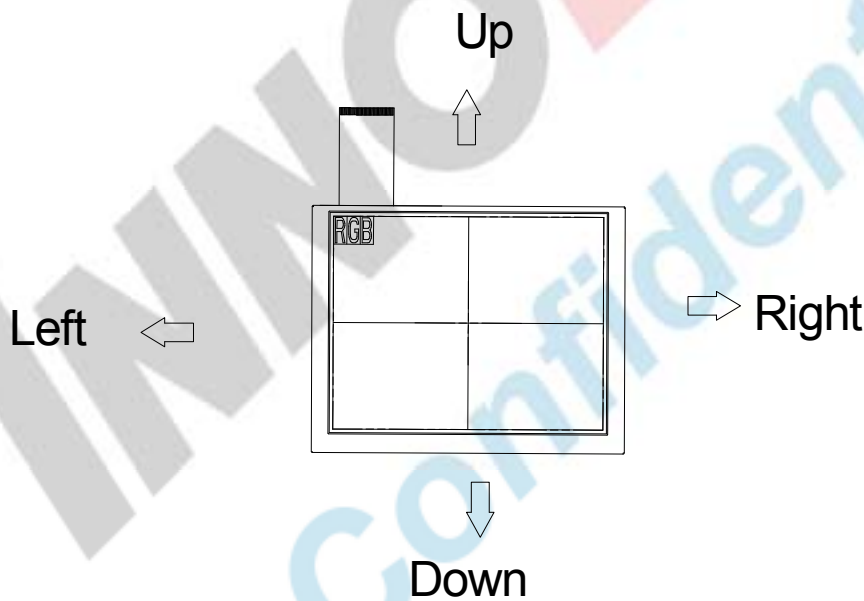

### 3.Operation Specifications

#### 3.1.Absolute Maximum Rating

(Note 1)

Item	Symbol	Values		Unit	Remark
		Min.	Max.		
Power voltage	V <sub>CC</sub>	-0.3	7	V	
	V <sub>LED</sub>	4.5	5.5	V	
Operation Temperature	T <sub>OP</sub>	-20	70	°C	
Storage Temperature	T <sub>ST</sub>	-30	80	°C	

Note 1: The absolute maximum rating values of this product are not allowed to be exceeded at any times. Should a module be used with any of the absolute maximum ratings exceeded, the characteristics of the module may not be recovered, or in an extreme case, the module may be permanently destroyed.



### 3.2. Typical Operation Conditions

Item	Symbol	Values			Unit	Remark
		Min.	Typ.	Max.		
Power voltage	V <sub>CC</sub>	3.1	3.3	3.5	V	Note 1
	V <sub>LED</sub>	4.8	5.0	5.2	V	Note 2
Current consumption	I <sub>CC</sub>	-	200	300	mA	
	I <sub>LED</sub>	-	300	400	mA	Note 3
Input logic high voltage	V <sub>IH</sub>	0.7V <sub>CC</sub>	-	1V <sub>CC</sub>	V	Note 4
Input logic low voltage	V <sub>IL</sub>	0	-	0.3V <sub>CC</sub>	V	
LED life time	-	20,000	-	-	Hr	Note 5

Note 1: V<sub>CC</sub> setting should match the signals output voltage (refer to Note 4) of customer's system board.

Note 2: LED driving voltage.

Note 3: LED driving current.

Note 4: DCLK, DE, HS, VS, R0~ R5, G0~ G5, B0~ B5.

Note 5: The "LED life time" is defined as the module brightness decrease to 50% original brightness at Ta=25°C and V<sub>LED</sub>=5.0V. The LED lifetime could be decreased if operating V<sub>LED</sub> is larger than 5.0V.

### 3.3. Power Sequence

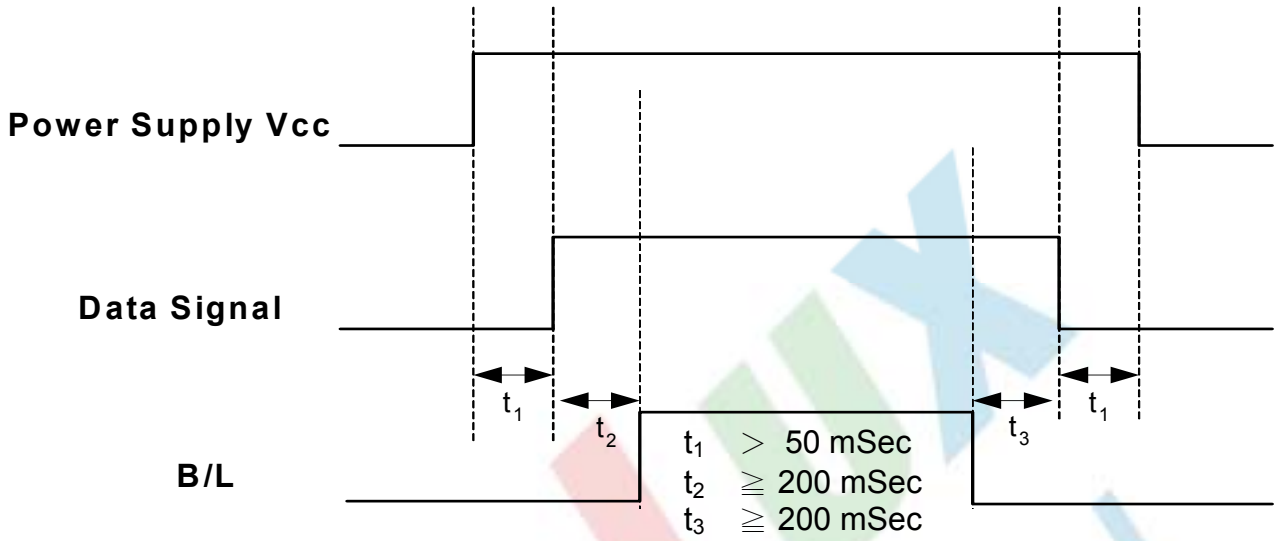

Note: Data includes DE, VS, HS, B0~B5, G0~G5, R0~R5, DCLK.

INNOLUX Confidential

### 3.4. Timing Characteristics

#### 3.4.1. Timing Conditions

Input/Output Timing

Item	Symbol	Values			Unit.	Remark
		Min.	Typ.	Max.		
PXLCLK clock time	Tclk	33.3	39.7	-	ns	1 Tclk
PXLCLK pulse duty	Tcwh	40	50	60	%	Tclk
DATA set-up time	Tdsu	12	-	-	ns	DATA to PXLCLK
DATA hold time	Tdhd	12	-	-	ns	DATA to PXLCLK
DE setup time	Tesu	12	-	-	ns	DE to PXLCLK
VSYNC setup time	Tvst	12	-	-	ns	
VSYNC hold time	Tvhd	12	-	-	ns	
HSYNC setup time	Thst	12	-	-	ns	
HSYNC hold time	Thhd	12	-	-	ns	
HSYNC period time	Th	22.91	31.76	-	us	
HSYNC width	Thwh	1	-	-	Tclk	
VSYNC width	Tvwh	1	-	-	Th	
HSYNC to CLKIN	Thc	-	-	1	Tclk	

DE Mode input Timing Limitation

DE Mode	Values			Unit	Remark
	Min.	Typ.	Max.		
THC	48	160	765	tclk	
THD	640	640	640	tclk	
TH	688	800	1405	tclk	1TH=1line
TVC	6	45	255	Line	
TVD	480	480	480	line	
TV	486	525	735	line	1TV=1field

版權屬於群創所有，禁止任何未經授權的使用

HV Mode input Timing Limitation

HV Mode	Values			Unit	Remark
	Min.	Typ.	Max.		
Thwh	-	10	-	tclk	
Thbp	-	134	-	tclk	
Thfp	-	16	-	tclk	
THD	-	640	-	tclk	
TH	-	800	-	line	
Tvwh	-	2	-	line	
Tvbp	-	11	-	line	
Tvfp	-	32	-	line	
TVD	-	480	-	line	
TV	-	525	-	line	1TV=1field

3.4.2. Timing Diagram

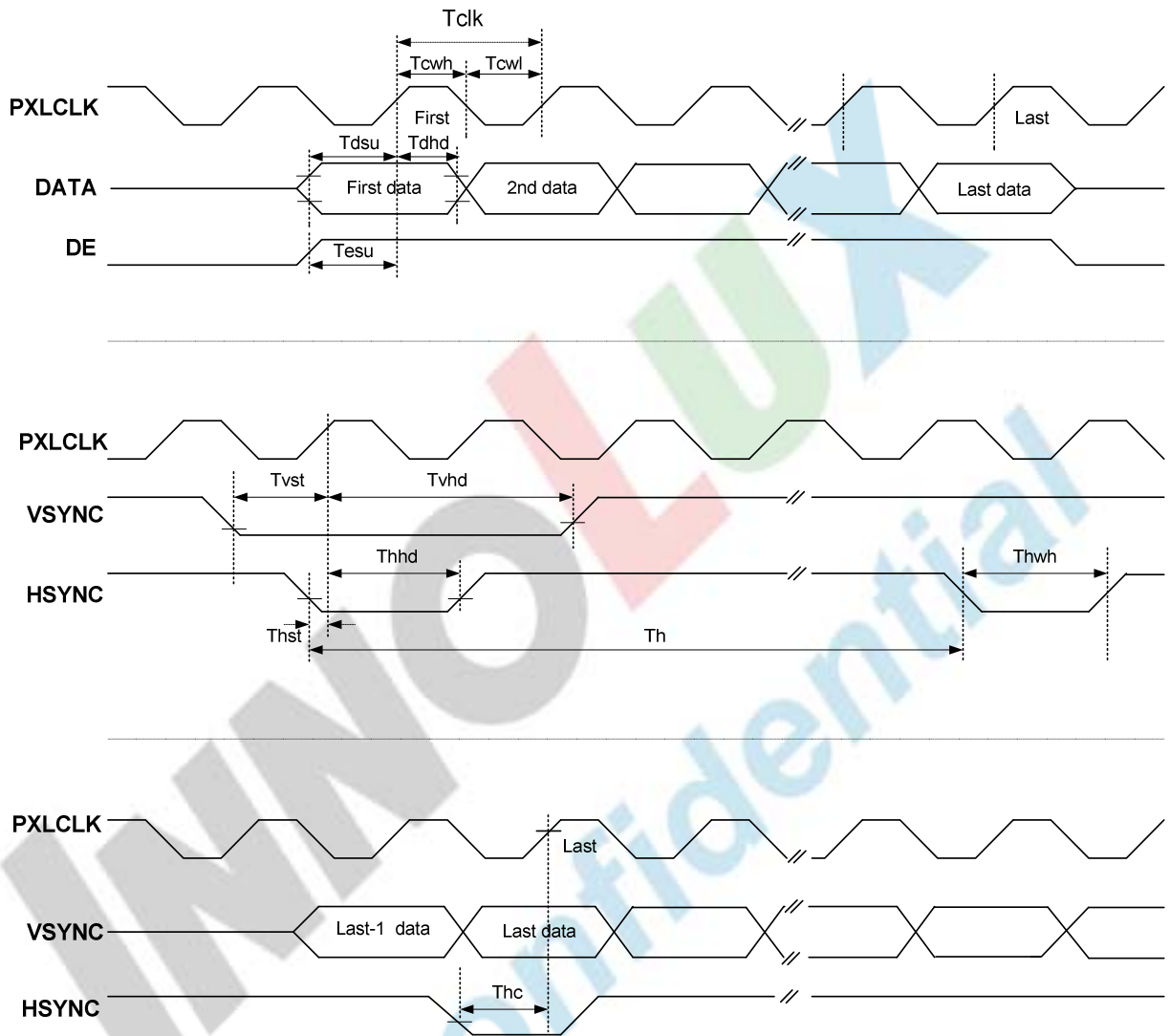

Fig.3-1 Clock and Data Input Timing Diagram

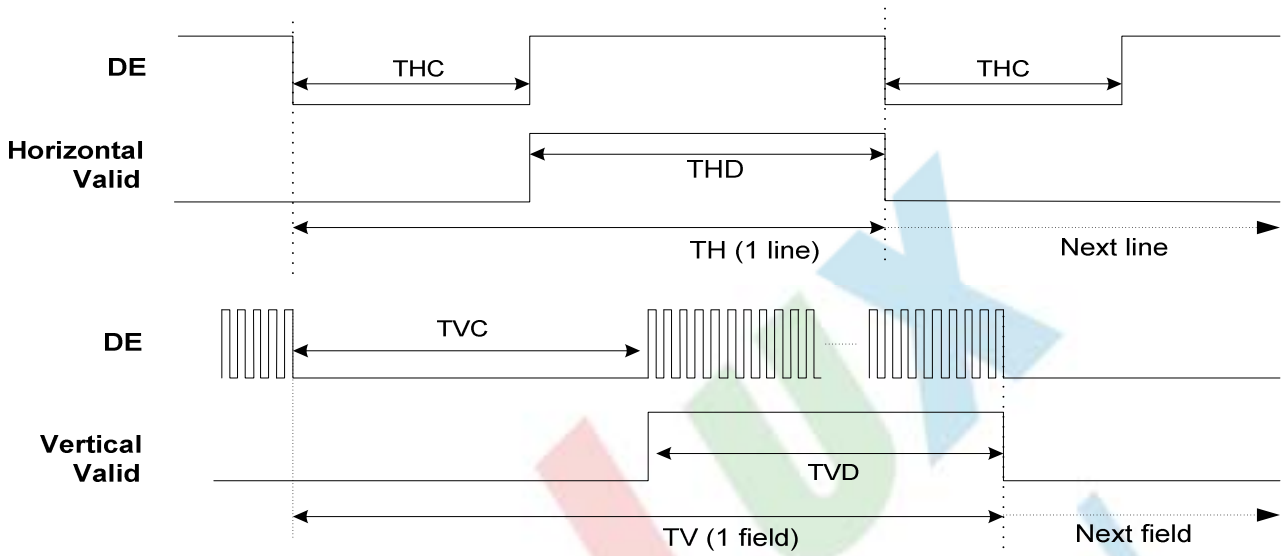

Fig.3-2 DE Mode Input Timing

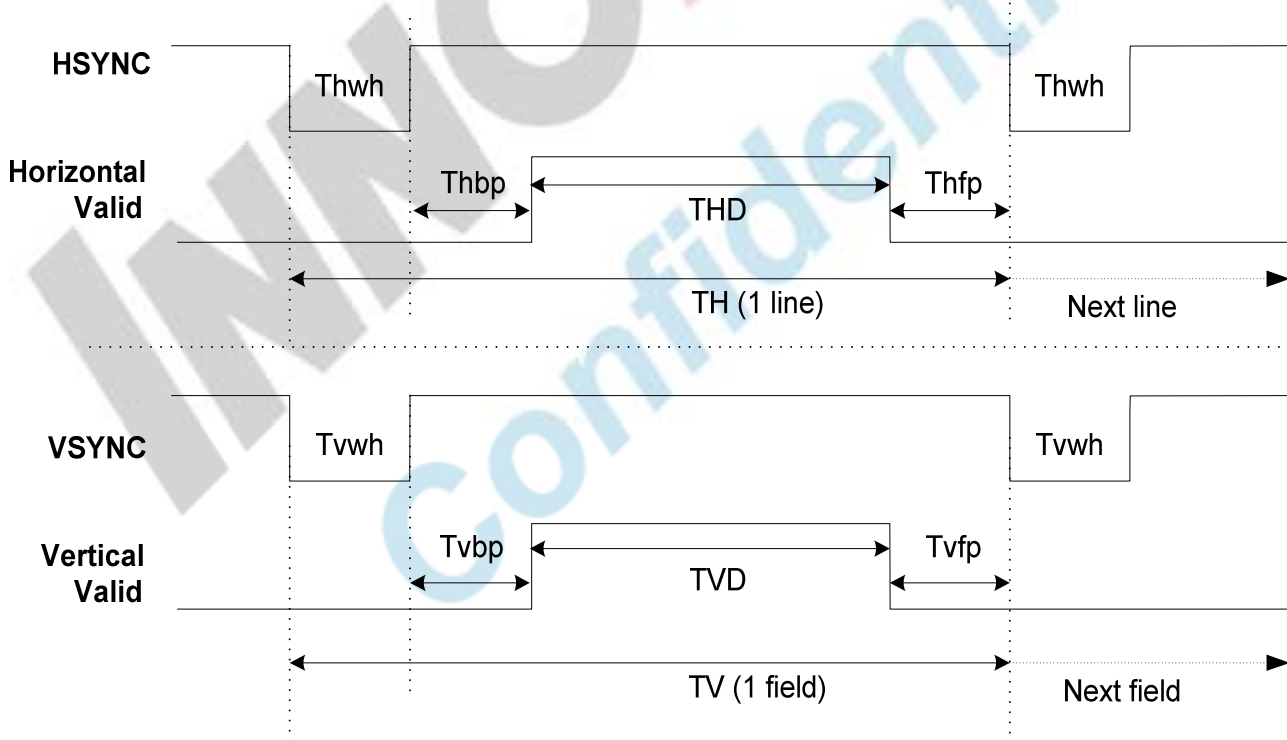

Fig.3-3 HV Mode Input Timing

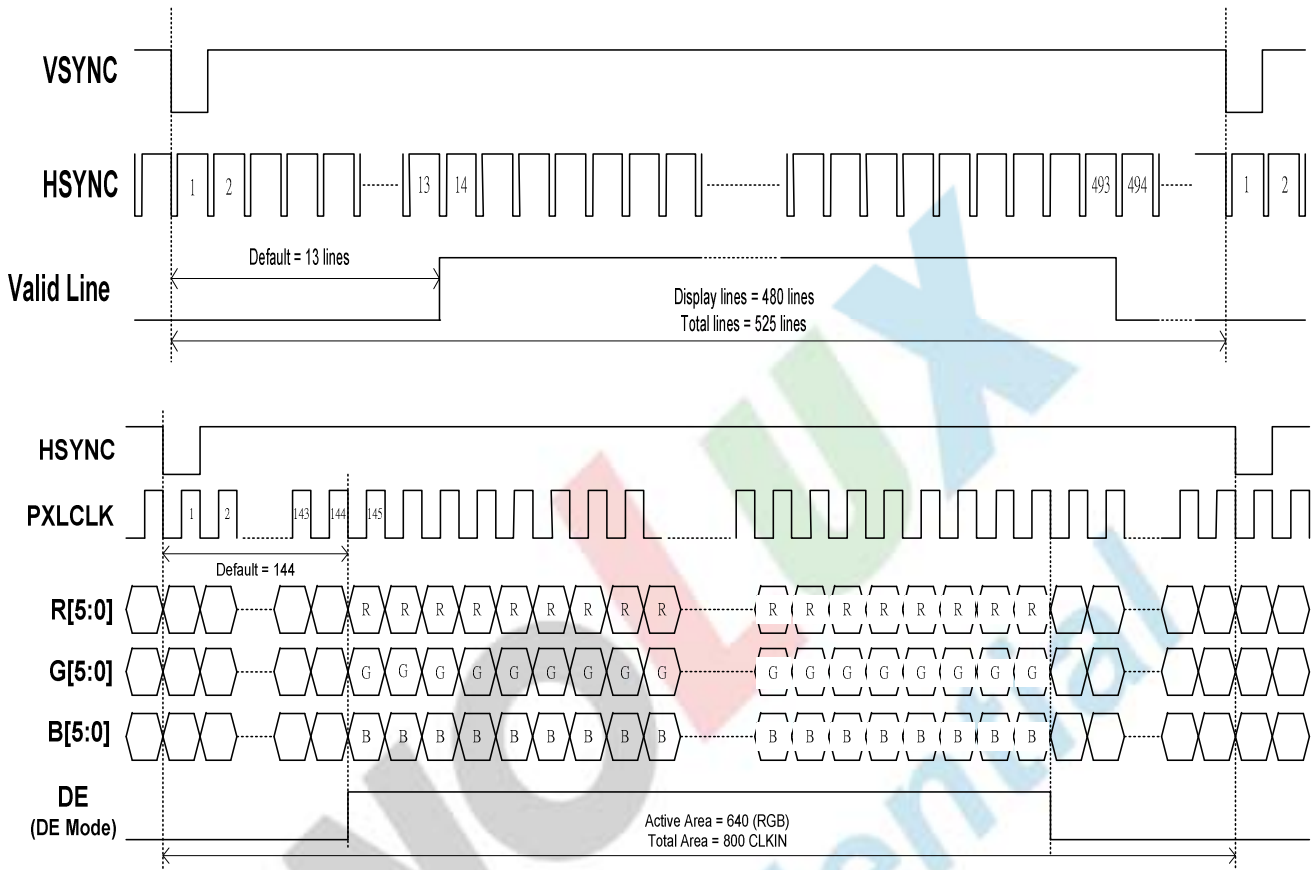

Fig. 3-4 18 bit RGB mode for 640 x(RGB)x 480

## 4. Optical Specification

Item	Symbol	Condition	Values			Unit	Remark
			Min.	Typ.	Max.		
Viewing angle (CR≥10)	$\theta_L$	$\Phi=180^\circ$ (9 o'clock)	60	70	-	degree	Note 1
	$\theta_R$	$\Phi=0^\circ$ (3 o'clock)	60	70	-		
	$\theta_T$	$\Phi=90^\circ$ (12 o'clock)	40	50	-		
	$\theta_B$	$\Phi=270^\circ$ (6 o'clock)	60	70	-		
Response time	$T_{ON}$	Normal $\theta=\Phi=0^\circ$	-	10	20	msec	Note 3
	$T_{OFF}$		-	15	30	msec	Note 3
Contrast ratio	CR		400	500	-	-	Note 4
Color chromaticity	$W_X$		0.26	0.31	0.36	-	Note 2 Note 5 Note 6
	$W_Y$		0.28	0.33	0.38	-	
Luminance	L		150	200	-	cd/m <sup>2</sup>	Note 6
Luminance uniformity	$Y_U$		70	75	-	%	Note 6,7

**Test Conditions:**

1.  $V_{CC}=3.3V$ ,  $V_{LED}=5.0V$ , the ambient temperature is  $25^\circ C$ .
2. The test systems refer to Note 2.



Note 1: Definition of viewing angle range

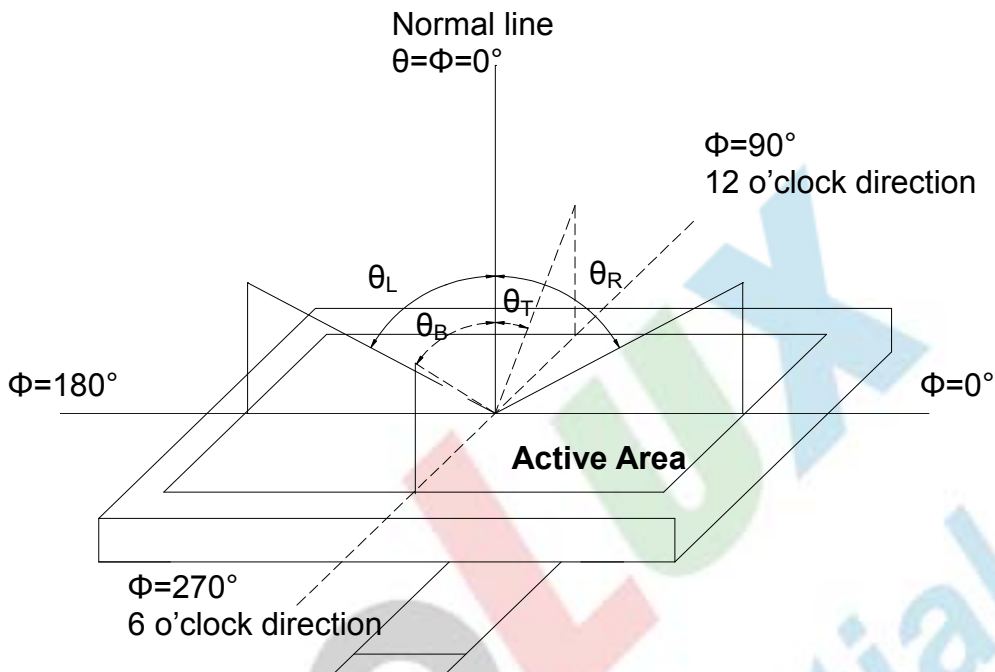

Fig. 4-1 Definition of viewing angle

Note 2: Definition of optical measurement system.

The optical characteristics should be measured in dark room. The optical properties are measured at the center point of the LCD screen. (Response time is measured by Photo detector TOPCON BM-7, other items are measured by BM-5A/Field of view:  $1^\circ$  /Height: 500mm.)

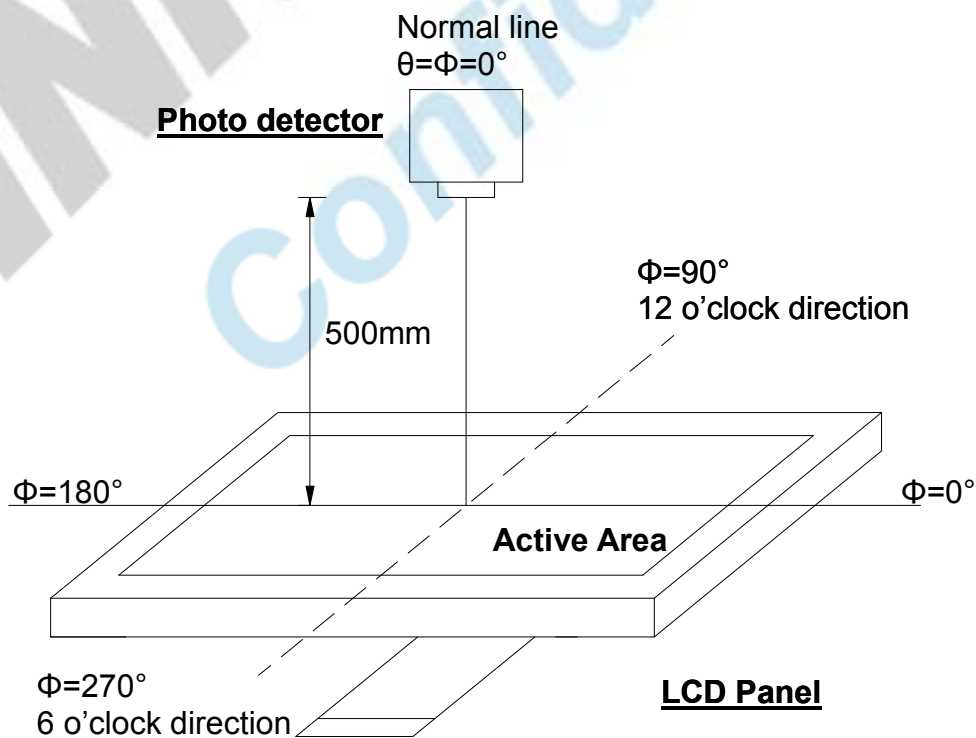

Fig. 4-2 Optical measurement system setup

The copyright belongs to InnoLux. Any unauthorized use is prohibited.

Note 3: Definition of Response time

The response time is defined as the LCD optical switching time interval between "White" state and "Black" state. Rise time ( $T_{ON}$ ) is the time between photo detector output intensity changed from 90% to 10%. And fall time ( $T_{OFF}$ ) is the time between photo detector output intensity changed from 10% to 90%.

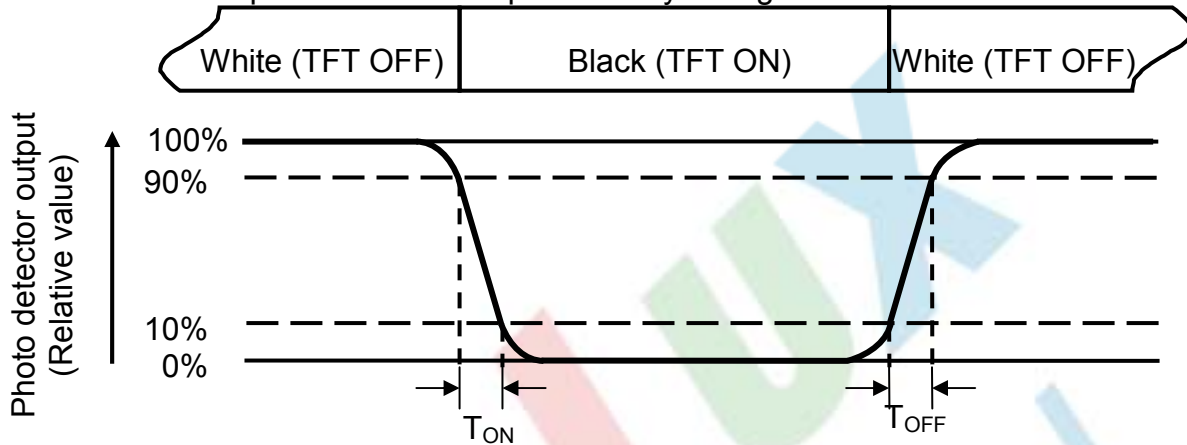

Fig. 4-3 Definition of response time

Note 4: Definition of contrast ratio

$$\text{Contrast ratio (CR)} = \frac{\text{Luminance measured when LCD on the "White" state}}{\text{Luminance measured when LCD on the "Black" state}}$$

Note 5: Definition of color chromaticity (CIE1931)

Color coordinates measured at center point of LCD.

Note 6: All input terminals LCD panel must be ground while measuring the center area of the panel. The LED driving condition is  $V_{LED} = 5.0V$ .

Note 7: Definition of Luminance Uniformity

Active area is divided into 9 measuring areas (Refer to Fig. 4-4 ).Every measuring point is placed at the center of each measuring area.

$$\text{Luminance Uniformity (Yu)} = \frac{B_{min}}{B_{max}}$$

L-----Active area length      W----- Active area width

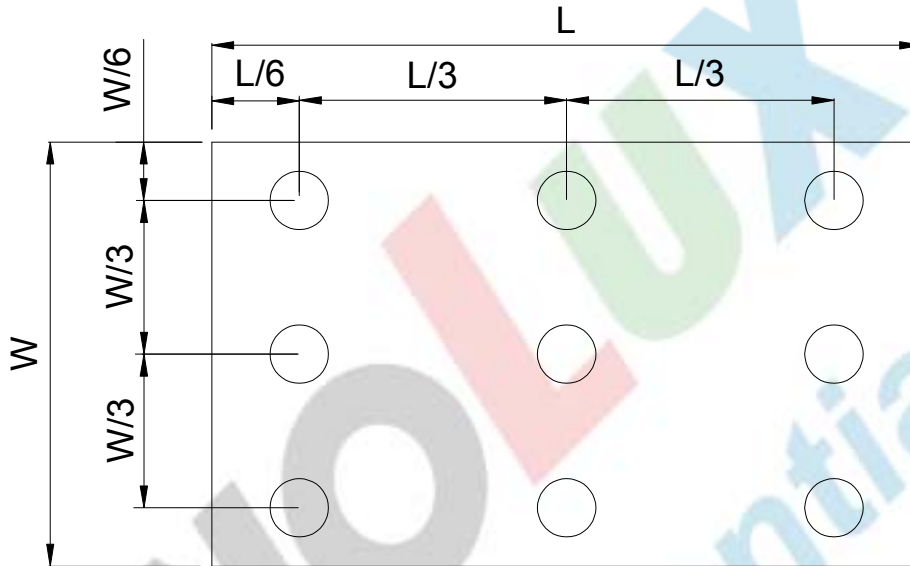

Fig. 4-4 Definition of measuring points

**B<sub>max</sub>**: The measured maximum luminance of all measurement position.

**B<sub>min</sub>**: The measured minimum luminance of all measurement position.

## 5. Reliability Test

(Note3)

Item	Test Conditions	Remark
High Temperature Storage	Ta = 80°C                                      240 hrs	Note 1, 4
Low Temperature Storage	Ta = -30°C                                      240hrs	Note 1, 4
High Temperature Operation	Ts = 70°C                                      240hrs	Note 2, 4
Low Temperature Operation	Ta = -20°C                                      240hrs	Note 1, 4
Operate at High Temperature and Humidity	+40°C, 90%RH                              240 hrs	Note 4
Thermal Shock	-30°C/30 min ~ +80°C/30 min for a total 100 cycles, Start with cold temperature and end with high temperature	Note 4
Vibration Test	Frequency range:10~55Hz Stroke:1.5mm Sweep:10Hz~55Hz~10Hz 2 hours for each direction of X. Y. Z. (6 hours for total)	
Mechanical Shock	100G 6ms,±X, ±Y, ±Z 3 times for each direction	
Package Vibration Test	Random Vibration : 0.015G*G/Hz from 5-200HZ, -6dB/Octave from 200-500HZ 2 hours for each direction of X. Y. Z. (6 hours for total)	
Package Drop Test	Height:60 cm 1 corner, 3 edges, 6 surfaces	
Electro Static Discharge	± 2KV, Human Body Mode, 100pF/1500Ω	

Note 1: Ta is the ambient temperature of samples.

Note 2: Ts is the temperature of panel's surface.

Note 3: In the standard condition, there shall be no practical problem that may affect the display function. After the reliability test, the product only guarantees operation, but doesn't guarantee all the cosmetic specification.

Note 4: Before cosmetic and function tests , the product must have enough recovery time, at least 2 hours at room temperature.

## 6. General Precautions

### 6.1. Safety

Liquid crystal is poisonous. Do not put it in your mouth. If liquid crystal touches your skin or clothes, wash it off immediately by using soap and water.

### 6.2. Handling

1. The LCD panel is plate glass. Do not subject the panel to mechanical shock or to excessive force on its surface.
2. The polarizer attached to the display is easily damaged. Please handle it carefully to avoid scratch or other damages.
3. To avoid contamination on the display surface, do not touch the module surface with bare hands.
4. Keep a space so that the LCD panels do not touch other components.
5. Put cover board such as acrylic board on the surface of LCD panel to protect panel from damages.
6. Transparent electrodes may be disconnected if you use the LCD panel under environmental conditions where the condensation of dew occurs.
7. Do not leave module in direct sunlight to avoid malfunction of the ICs.

### 6.3. Static Electricity

1. Be sure to ground module before turning on power or operating module.
2. Do not apply voltage which exceeds the absolute maximum rating value.

### 6.4. Storage

1. Store the module in a dark room where must keep at  $25\pm 10^{\circ}\text{C}$  and 65%RH or less.
2. Do not store the module in surroundings containing organic solvent or corrosive gas.
3. Store the module in an anti-electrostatic container or bag.

### 6.5. Cleaning

1. Do not wipe the polarizer with dry cloth. It might cause scratch.
2. Only use a soft sloth with IPA to wipe the polarizer, other chemicals might permanent damage to the polarizer.

# 7.Mechanical Drawing

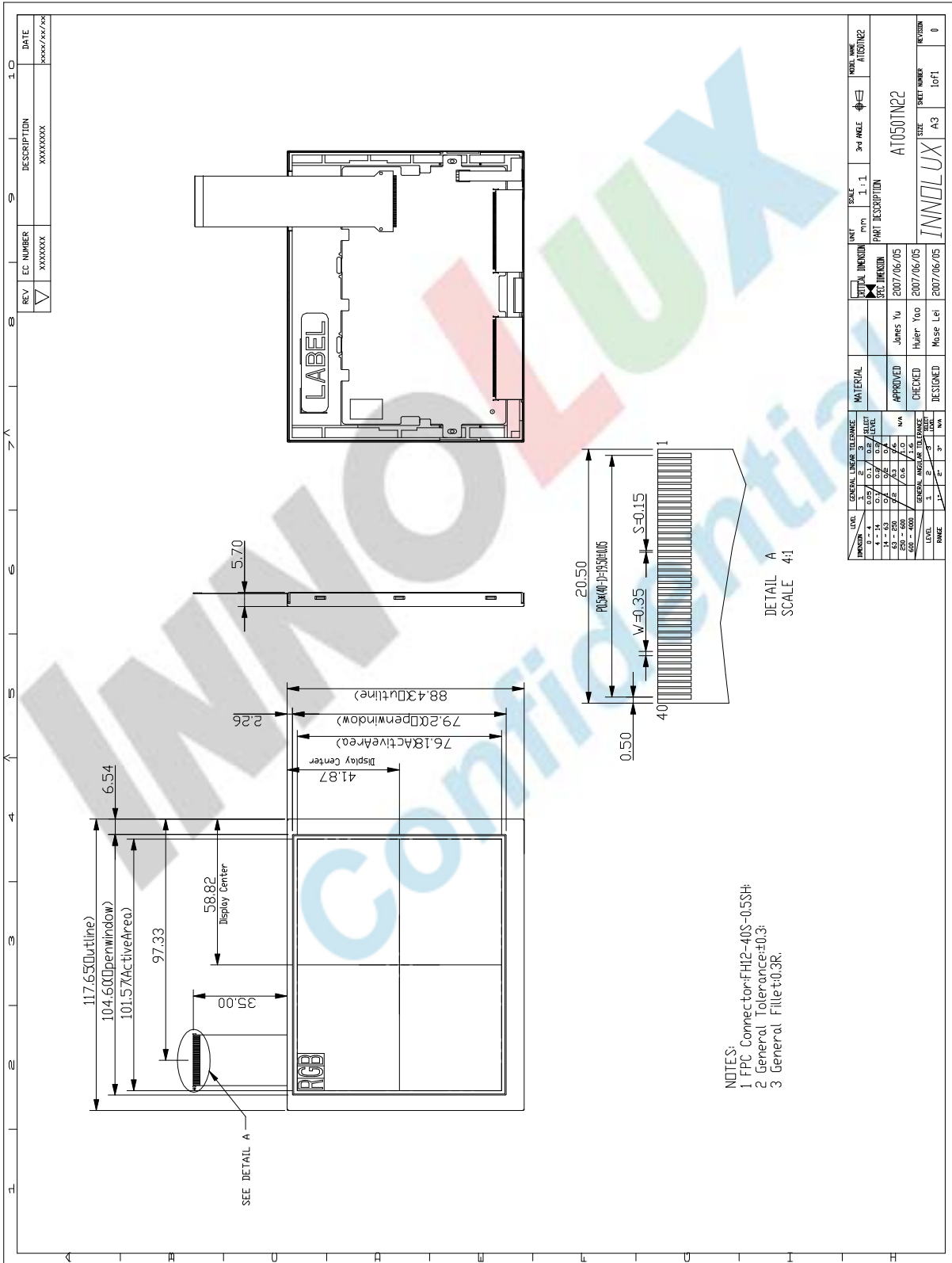

- NOTES:  
 1 FPC Connector: FH12-40S-0.5SH  
 2 General Tolerance: ±0.3  
 3 General Fillet: 0.3R.

REV	EC NUMBER	DESCRIPTION	DATE
▽	XXXXXX	XXXXXXXX	xxxx/xx/xx

LEVEL	GENERAL TOLERANCE	REL TOLERANCE	LEVEL	GENERAL TOLERANCE	REL TOLERANCE
0 - 1	0.15	0.05	0 - 1	0.15	0.05
2 - 3	0.20	0.07	2 - 3	0.20	0.07
4 - 5	0.25	0.09	4 - 5	0.25	0.09
6 - 7	0.30	0.11	6 - 7	0.30	0.11
8 - 9	0.35	0.13	8 - 9	0.35	0.13
10 - 11	0.40	0.15	10 - 11	0.40	0.15
12 - 13	0.45	0.17	12 - 13	0.45	0.17
14 - 15	0.50	0.19	14 - 15	0.50	0.19
16 - 17	0.55	0.21	16 - 17	0.55	0.21
18 - 19	0.60	0.23	18 - 19	0.60	0.23
20 - 21	0.65	0.25	20 - 21	0.65	0.25
22 - 23	0.70	0.27	22 - 23	0.70	0.27
24 - 25	0.75	0.29	24 - 25	0.75	0.29
26 - 27	0.80	0.31	26 - 27	0.80	0.31
28 - 29	0.85	0.33	28 - 29	0.85	0.33
30 - 31	0.90	0.35	30 - 31	0.90	0.35
32 - 33	0.95	0.37	32 - 33	0.95	0.37
34 - 35	1.00	0.39	34 - 35	1.00	0.39
36 - 37	1.05	0.41	36 - 37	1.05	0.41
38 - 39	1.10	0.43	38 - 39	1.10	0.43
40 - 41	1.15	0.45	40 - 41	1.15	0.45
42 - 43	1.20	0.47	42 - 43	1.20	0.47
44 - 45	1.25	0.49	44 - 45	1.25	0.49
46 - 47	1.30	0.51	46 - 47	1.30	0.51
48 - 49	1.35	0.53	48 - 49	1.35	0.53
50 - 51	1.40	0.55	50 - 51	1.40	0.55
52 - 53	1.45	0.57	52 - 53	1.45	0.57
54 - 55	1.50	0.59	54 - 55	1.50	0.59
56 - 57	1.55	0.61	56 - 57	1.55	0.61
58 - 59	1.60	0.63	58 - 59	1.60	0.63
60 - 6000	1.65	0.65	60 - 6000	1.65	0.65

DATE	2007/06/05	DESIGNED	Mose Lei
DATE	2007/06/05	CHECKED	Hui Yu
DATE	2007/06/05	APPROVED	Jones Yu
DATE	2007/06/05	SPEC INCHARGE	Jones Yu
DATE	2007/06/05	3rd ANGLE	
DATE	2007/06/05	SCALE	1:1
DATE	2007/06/05	PART DESCRIPTION	INNOLUX
DATE	2007/06/05	SHEET NUMBER	10f1
DATE	2007/06/05	REVISION	0

版權屬於群創所有，禁止任何未經授權的使用

## 8.Package Drawing

### 8.1.Packaging Material Table

No.	Item	Model (Material)	Dimensions(mm)	Unit Weight (kg)	Quantity	Remark
1	LCM Module	AT050TN22	117.65X88.43X5.7	0.075	68pcs	
2	Partition	B Corrugated paper	512 X 349 X 226	1.150	1set	
3	Corrugated Bar	B Corrugated paper	349 X 198 X 49	0.316	1set	
4	Corrugated Board	B Corrugated paper	512 X 349	0.098	2pcs	
5	Dust-Proof Bag	PE	700 X 530	0.060	1pcs	
6	A/S Bag	PE	180 X 133 X 0.2	0.002	68pcs	
7	Carton	Corrugated paper	530 X 355 X 255	1.100	1 pcs	
8	Total Weight	7.800kg ± 5%				

### 8.2.Packaging Quantity

Total LCM quantity in Carton: no. of Partition	4 Rows x quantity per Row 17= 68
------------------------------------------------	----------------------------------

### 8.3.Package Drawing

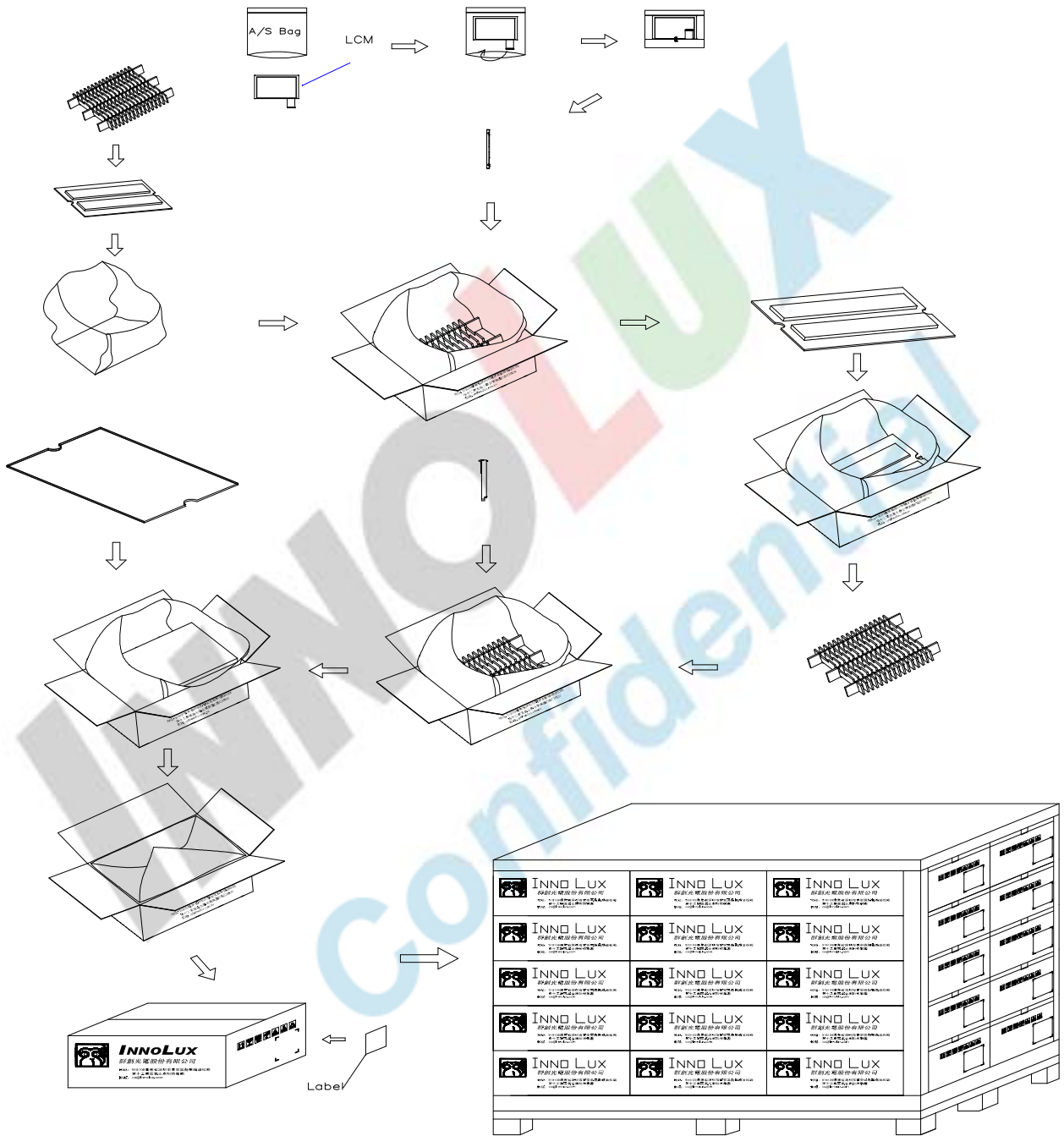

版權屬於群創所有，禁止任何未經授權的使用

The copyright belongs to InnoLux. Any unauthorized use is prohibited.