



宁波广星电子有限公司

产品规格书



15EDGK-3.5
15EDGK-3.81

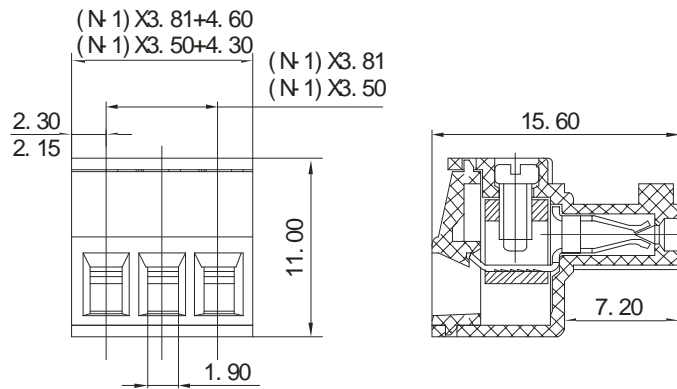

A 向视图

认证		
电气性能		
参考标准	UL	IEC
额定电压	300V	250V
额定电流	8A	7A
使用线径	28-16AWG	0.5-1.5mm ²
耐电压	AC2000V/1Min	
机械性能		
扭力矩	0.2Nm(1.7Lb-In)	
温度范围	-40°C~+105°C	
剥线长度	7mm	
尺寸		
间距	3.5mm(.138") 3.81mm(.150")	
极数	2P-24P	
材质和电镀		
塑件	PA66,UL94V-0	
螺丝	M2,钢,镀Cr ³⁺ 钝化彩锌	
触点材料	磷青铜	
方盒	黄铜,镀镍	

订购方式:

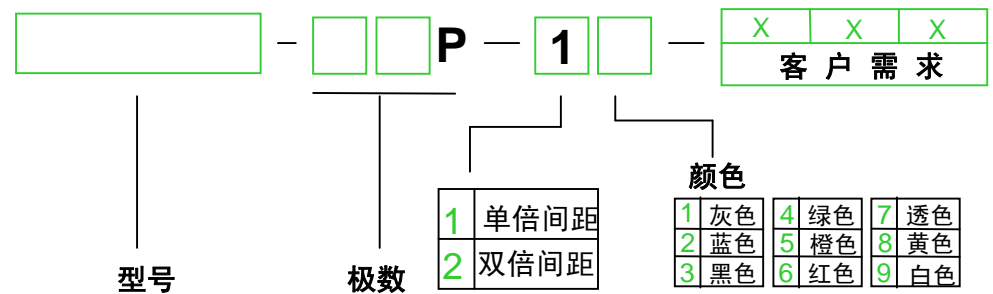

	宁波广星电子有限公司
	NAME 15EDGK-3.5, 15EDGK-3.81