

The RF Sub-Micron MOSFET Line
RF Power Field Effect Transistors
N-Channel Enhancement-Mode Lateral MOSFETs

Designed for broadband commercial and industrial applications with frequencies from 865 to 895 MHz. The high gain and broadband performance of these devices make them ideal for large-signal, common-source amplifier applications in 26 volt base station equipment.

- Typical CDMA Performance @ 880 MHz, 26 Volts, $I_{DQ} = 700$ mA
IS-97 CDMA Pilot, Sync, Paging, Traffic Codes 8 Through 13
Output Power — 20 Watts
Power Gain — 17.9 dB
Efficiency — 28%
Adjacent Channel Power —
750 kHz: -45.0 dBc @ 30 kHz BW
1.98 MHz: -60.0 dBc @ 30 kHz BW
- Internally Matched, Controlled Q, for Ease of Use
- High Gain, High Efficiency and High Linearity
- Integrated ESD Protection
- Designed for Maximum Gain and Insertion Phase Flatness
- Capable of Handling 10:1 VSWR, @ 26 Vdc, 880 MHz, 90 Watts CW Output Power
- Excellent Thermal Stability
- Characterized with Series Equivalent Large-Signal Impedance Parameters
- Available in Tape and Reel. R3 Suffix = 250 Units per 56 mm, 13 inch Reel.
- Available with Low Gold Plating Thickness on Leads. L Suffix Indicates 40 μ " Nominal.

MRF9085
MRF9085R3
MRF9085SR3
MRF9085LSR3

880 MHz, 90 W, 26 V
LATERAL N-CHANNEL
RF POWER MOSFETs

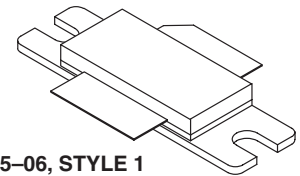

CASE 465-06, STYLE 1
(NI-780)
(MRF9085)

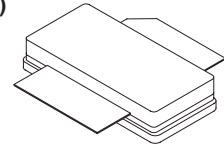

CASE 465A-06, STYLE 1
(NI-780S)
(MRF9085SR3, MRF9085LSR3)

MAXIMUM RATINGS

Rating	Symbol	Value	Unit
Drain-Source Voltage	V_{DSS}	65	Vdc
Gate-Source Voltage	V_{GS}	+15, -0.5	Vdc
Total Device Dissipation @ $T_C = 25^\circ\text{C}$ Derate above 25 $^\circ\text{C}$	P_D	250 1.43	Watts W/ $^\circ\text{C}$
Storage Temperature Range	T_{stg}	-65 to +200	$^\circ\text{C}$
Operating Junction Temperature	T_J	200	$^\circ\text{C}$

ESD PROTECTION CHARACTERISTICS

Test Conditions	Class
Human Body Model	1 (Minimum)
Machine Model MRF9085 MRF9085SR3/MRF9085LSR3	M2 (Minimum) M1 (Minimum)

THERMAL CHARACTERISTICS

Characteristic	Symbol	Max	Unit
Thermal Resistance, Junction to Case	$R_{\theta JC}$	0.7	$^\circ\text{C}/\text{W}$

NOTE – CAUTION – MOS devices are susceptible to damage from electrostatic charge. Reasonable precautions in handling and packaging MOS devices should be observed.

ELECTRICAL CHARACTERISTICS ($T_C = 25^\circ\text{C}$ unless otherwise noted)

Characteristic	Symbol	Min	Typ	Max	Unit
----------------	--------	-----	-----	-----	------

OFF CHARACTERISTICS

Zero Gate Voltage Drain Leakage Current ($V_{DS} = 65\text{ Vdc}$, $V_{GS} = 0\text{ Vdc}$)	I_{DSS}	—	—	10	μAdc
Zero Gate Voltage Drain Leakage Current ($V_{DS} = 26\text{ Vdc}$, $V_{GS} = 0\text{ Vdc}$)	I_{DSS}	—	—	1	μAdc
Gate–Source Leakage Current ($V_{GS} = 5\text{ Vdc}$, $V_{DS} = 0\text{ Vdc}$)	I_{GSS}	—	—	1	μAdc

ON CHARACTERISTICS

Gate Threshold Voltage ($V_{DS} = 10\text{ Vdc}$, $I_D = 300\ \mu\text{Adc}$)	$V_{GS(th)}$	2.0	—	4.0	Vdc
Gate Quiescent Voltage ($V_{DS} = 26\text{ Vdc}$, $I_D = 700\ \text{mAdc}$)	$V_{GS(Q)}$	—	3.7	—	Vdc
Drain–Source On–Voltage ($V_{GS} = 10\text{ Vdc}$, $I_D = 2\ \text{Adc}$)	$V_{DS(on)}$	—	0.19	0.4	Vdc
Forward Transconductance ($V_{DS} = 10\text{ Vdc}$, $I_D = 6\ \text{Adc}$)	g_{fs}	—	8.0	—	S

DYNAMIC CHARACTERISTICS (1)

Output Capacitance ($V_{DS} = 26\text{ Vdc} \pm 30\ \text{mV(rms)ac}$ @ 1 MHz, $V_{GS} = 0\text{ Vdc}$)	C_{oss}	—	73	—	pF
Reverse Transfer Capacitance ($V_{DS} = 26\text{ Vdc} \pm 30\ \text{mV(rms)ac}$ @ 1 MHz, $V_{GS} = 0\text{ Vdc}$)	C_{rss}	—	2.9	—	pF

(1) Part is internally input matched.

(continued)

ELECTRICAL CHARACTERISTICS – continued ($T_C = 25^\circ\text{C}$ unless otherwise noted)

Characteristic	Symbol	Min	Typ	Max	Unit
FUNCTIONAL TESTS (In Motorola Test Fixture)					
Two-Tone Common-Source Amplifier Power Gain ($V_{DD} = 26\text{ Vdc}$, $P_{out} = 90\text{ W PEP}$, $I_{DQ} = 700\text{ mA}$, $f_1 = 880.0\text{ MHz}$, $f_2 = 880.1\text{ MHz}$)	G_{ps}	17	17.9	—	dB
Two-Tone Drain Efficiency ($V_{DD} = 26\text{ Vdc}$, $P_{out} = 90\text{ W PEP}$, $I_{DQ} = 700\text{ mA}$, $f_1 = 880.0\text{ MHz}$, $f_2 = 880.1\text{ MHz}$)	η	36	40	—	%
3rd Order Intermodulation Distortion ($V_{DD} = 26\text{ Vdc}$, $P_{out} = 90\text{ W PEP}$, $I_{DQ} = 700\text{ mA}$, $f_1 = 880.0\text{ MHz}$, $f_2 = 880.1\text{ MHz}$)	IMD	—	-31	-28	dBc
Input Return Loss ($V_{DD} = 26\text{ Vdc}$, $P_{out} = 90\text{ W PEP}$, $I_{DQ} = 700\text{ mA}$, $f_1 = 880.0\text{ MHz}$, $f_2 = 880.1\text{ MHz}$)	IRL	—	-21	-9	dB
Two-Tone Common-Source Amplifier Power Gain ($V_{DD} = 26\text{ Vdc}$, $P_{out} = 90\text{ W PEP}$, $I_{DQ} = 700\text{ mA}$, $f_1 = 865.0\text{ MHz}$, $f_2 = 865.1\text{ MHz}$)	G_{ps}	—	17.9	—	dB
Two-Tone Drain Efficiency ($V_{DD} = 26\text{ Vdc}$, $P_{out} = 90\text{ W PEP}$, $I_{DQ} = 700\text{ mA}$, $f_1 = 865.0\text{ MHz}$, $f_2 = 865.1\text{ MHz}$)	η	—	40.0	—	%
3rd Order Intermodulation Distortion ($V_{DD} = 26\text{ Vdc}$, $P_{out} = 90\text{ W PEP}$, $I_{DQ} = 700\text{ mA}$, $f_1 = 865.0\text{ MHz}$, $f_2 = 865.1\text{ MHz}$)	IMD	—	-31	—	dBc
Input Return Loss ($V_{DD} = 26\text{ Vdc}$, $P_{out} = 90\text{ W PEP}$, $I_{DQ} = 700\text{ mA}$, $f_1 = 865.0\text{ MHz}$, $f_2 = 865.1\text{ MHz}$)	IRL	—	-16	—	dB
Power Output, 1 dB Compression Point ($V_{DD} = 26\text{ Vdc}$, CW, $I_{DQ} = 700\text{ mA}$, $f_1 = 880.0\text{ MHz}$)	P_{1dB}	—	105	—	W
Common-Source Amplifier Power Gain ($V_{DD} = 26\text{ Vdc}$, $P_{out} = 90\text{ W CW}$, $I_{DQ} = 700\text{ mA}$, $f_1 = 880.0\text{ MHz}$)	G_{ps}	—	17.5	—	dB
Drain Efficiency ($V_{DD} = 26\text{ Vdc}$, $P_{out} = 90\text{ W CW}$, $I_{DQ} = 700\text{ mA}$, $f_1 = 880.0\text{ MHz}$)	η	—	51	—	%
Output Mismatch Stress ($V_{DD} = 26\text{ Vdc}$, $P_{out} = 90\text{ W CW}$, $I_{DQ} = 700\text{ mA}$, $f = 880.0\text{ MHz}$, VSWR = 10:1, All Phase Angles at Frequency of Tests)	Ψ	No Degradation In Output Power			

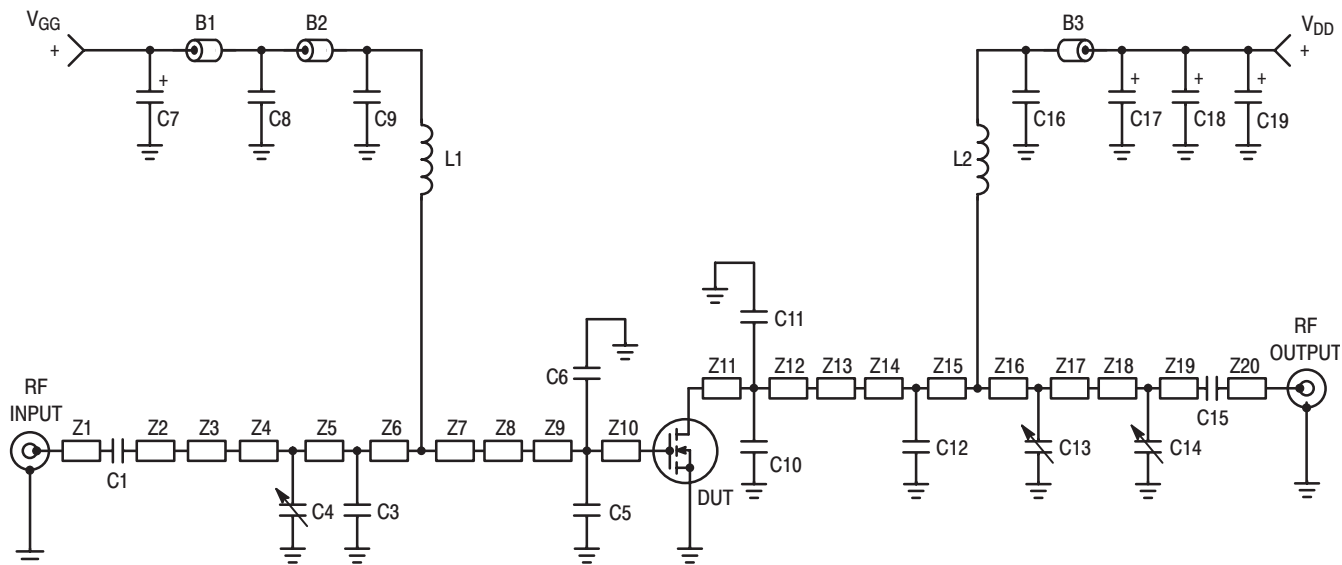

B1, B2, B3	Short Ferrite Beads, Surface Mount	Z6	0.076" x 0.220" Microstrip
C1, C9, C15, C16	47 pF Chip Capacitors, B Case, ATC	Z7	0.261" x 0.220" Microstrip
C3	5.6 pF Chip Capacitor, B Case, ATC	Z8	0.220" x 0.630" x 0.200" Taper
C4, C13	0.8 – 8.0 Variable Capacitors, Gigatrim	Z9	0.240" x 0.630" Microstrip
C5, C6, C12	10 pF Chip Capacitors, B Case, ATC	Z10	0.060" x 0.630" Microstrip
C7, C17, C18, C19	10 μ F, 35 V Tantalum Surface Mount Capacitors, Kemet	Z11	0.067" x 0.630" Microstrip
C8	20 K pF Chip Capacitor, B Case, ATC	Z12	0.233" x 0.630" Microstrip
C10, C11	16 pF Chip Capacitors, B Case, ATC	Z13	0.630" x 0.220" x 0.200" Taper
C14	0.6 – 4.5 Variable Capacitor, Gigatrim	Z14	0.200" x 0.220" Microstrip
L1	7.15 nH Inductor, Coilcraft	Z15	0.055" x 0.220" Microstrip
L2	18.5 nH Inductor, Coilcraft	Z16	0.088" x 0.220" Microstrip
N1, N2	N-Type Panel Mount, Stripline, M/A-Com	Z17	0.226" x 0.220" Microstrip
WB1, WB2	5 Mil BeCu Shim (0.225 x 0.525)	Z18	0.868" x 0.080" Microstrip
Z1	0.219" x 0.080" Microstrip	Z19	0.129" x 0.080" Microstrip
Z2	0.150" x 0.080" Microstrip	Z20	0.223" x 0.080" Microstrip
Z3	0.851" x 0.080" Microstrip	PCB	Etched Circuit Board, Glass, Teflon®
Z4	0.125" x 0.220" Microstrip		$\epsilon_r = 2.55, 30$ Mils
Z5	0.123" x 0.220" Microstrip		

Figure 1. 865–895 MHz Broadband Test Circuit Schematic

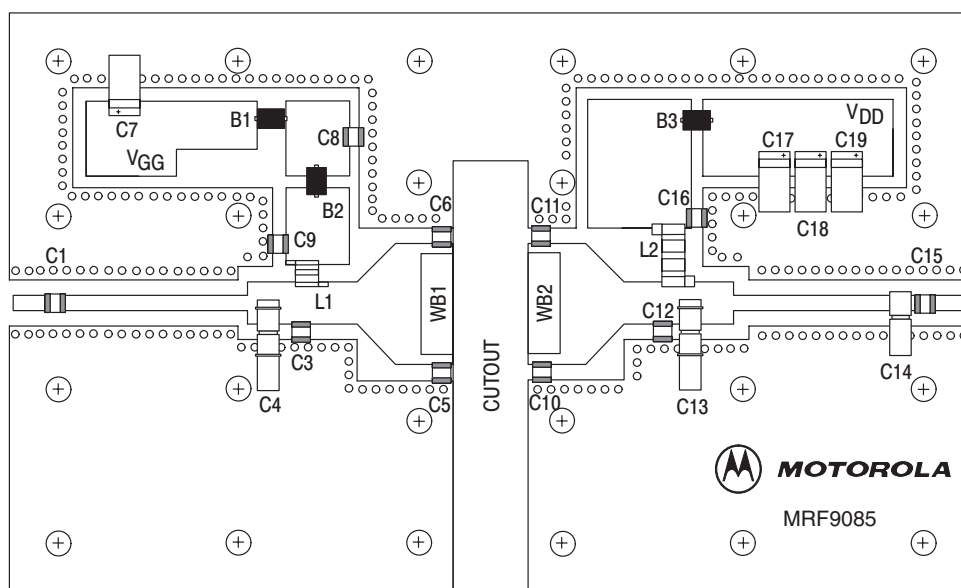

Figure 2. 865–895 MHz Broadband Test Circuit Component Layout

TYPICAL CHARACTERISTICS

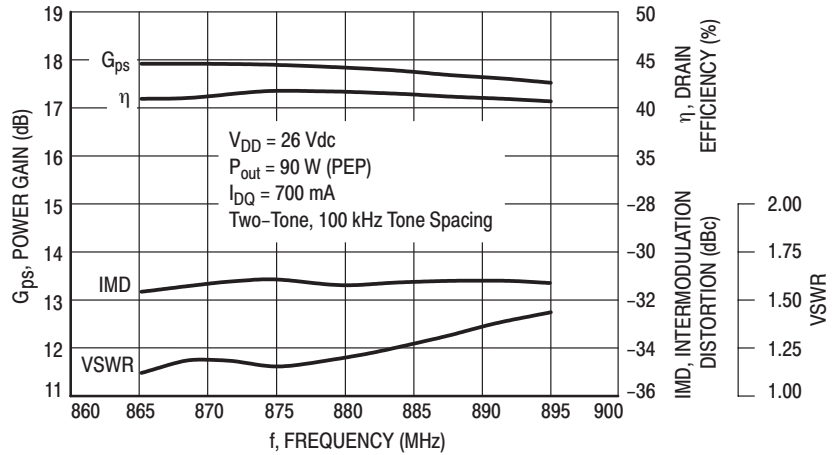

Figure 3. Class AB Broadband Circuit Performance

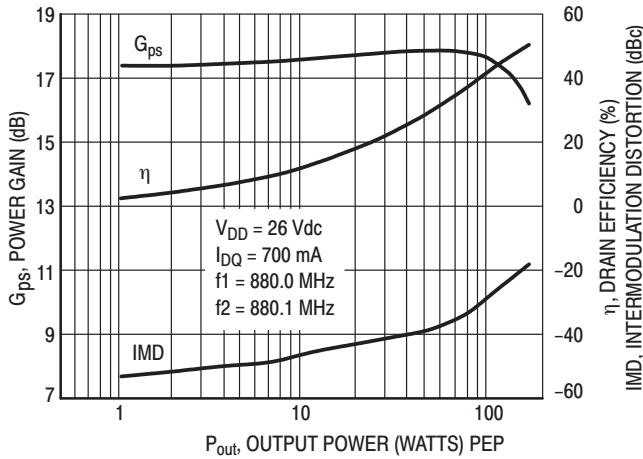

Figure 4. Power Gain, Efficiency, IMD versus Output Power

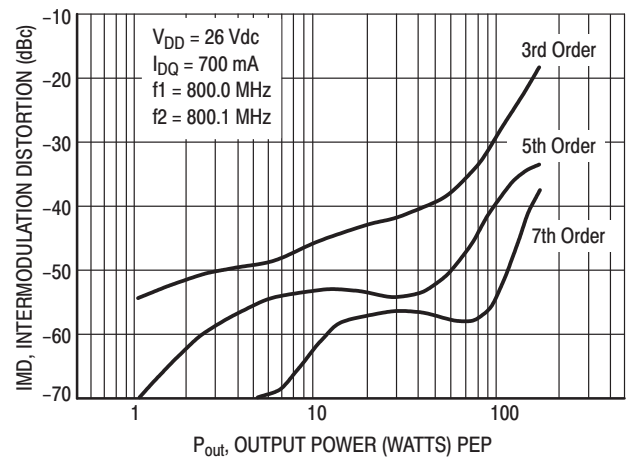

Figure 5. Intermodulation Distortion Products versus Output Power

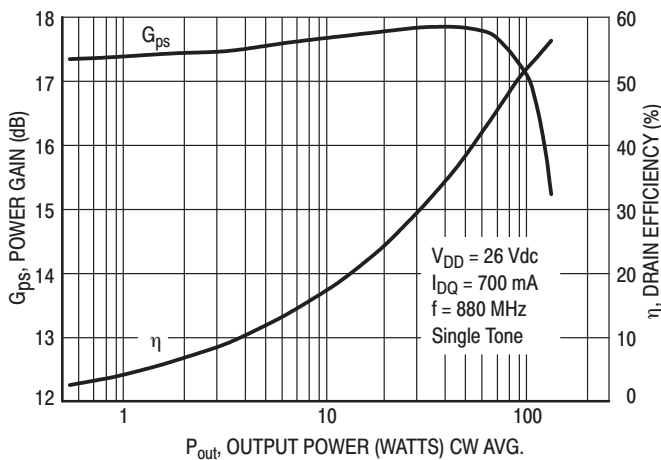

Figure 6. Power Gain, Efficiency versus Output Power

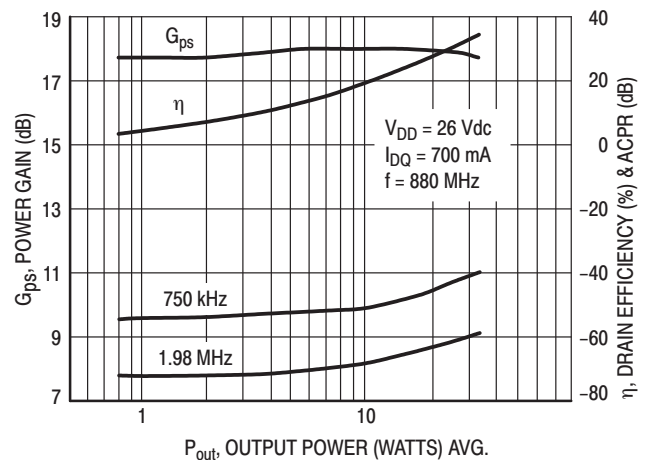
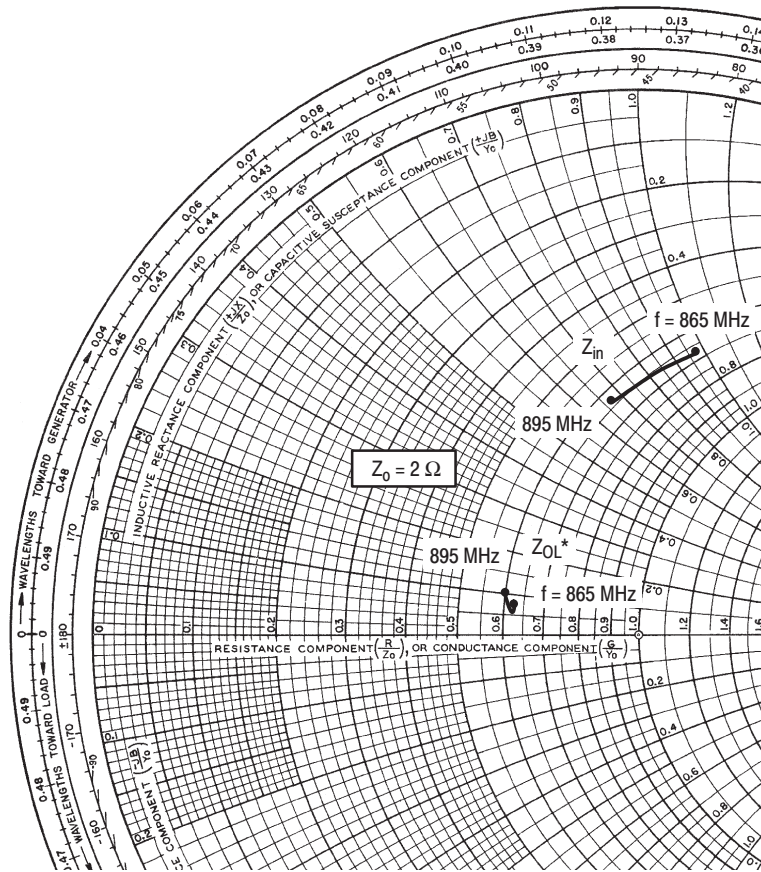

Figure 7. Power Gain, Efficiency, ACPR versus Output Power



$V_{DD} = 26\text{ V}$, $I_{DQ} = 700\text{ mA}$, $P_{out} = 90\text{ W PEP}$

f MHz	Z_{in} Ω	Z_{OL}^* Ω
865	$1.35 + j1.92$	$1.26 + j0.15$
880	$1.33 + j1.66$	$1.26 + j0.10$
895	$1.28 + j1.30$	$1.21 + j0.20$

Z_{in} = Complex conjugate of source impedance.

Z_{OL}^* = Complex conjugate of the optimum load impedance at a given output power, voltage, IMD, bias current and frequency.

Note: Z_{OL}^* was chosen based on tradeoffs between gain, output power, drain efficiency and intermodulation distortion.

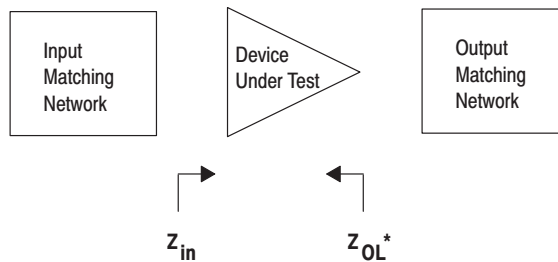
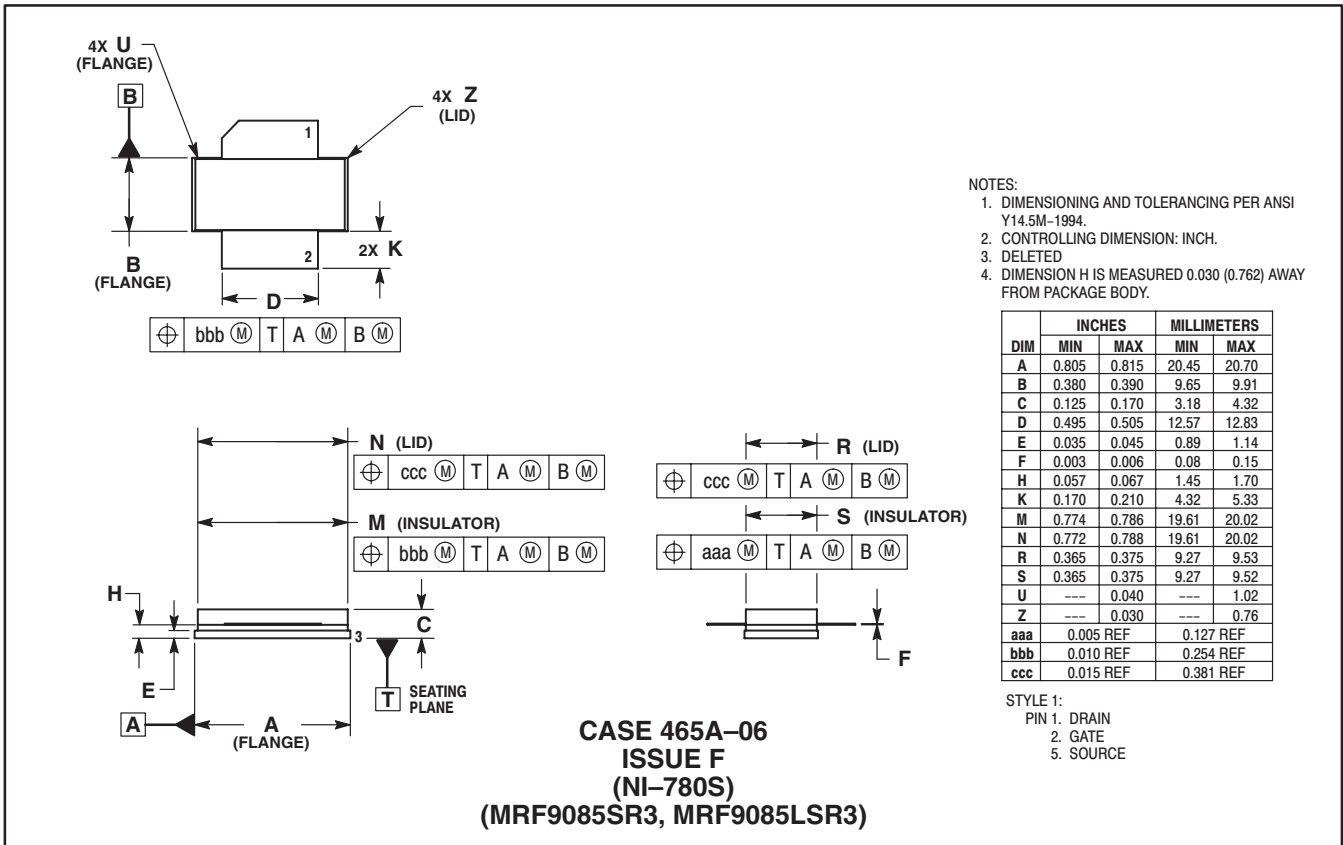
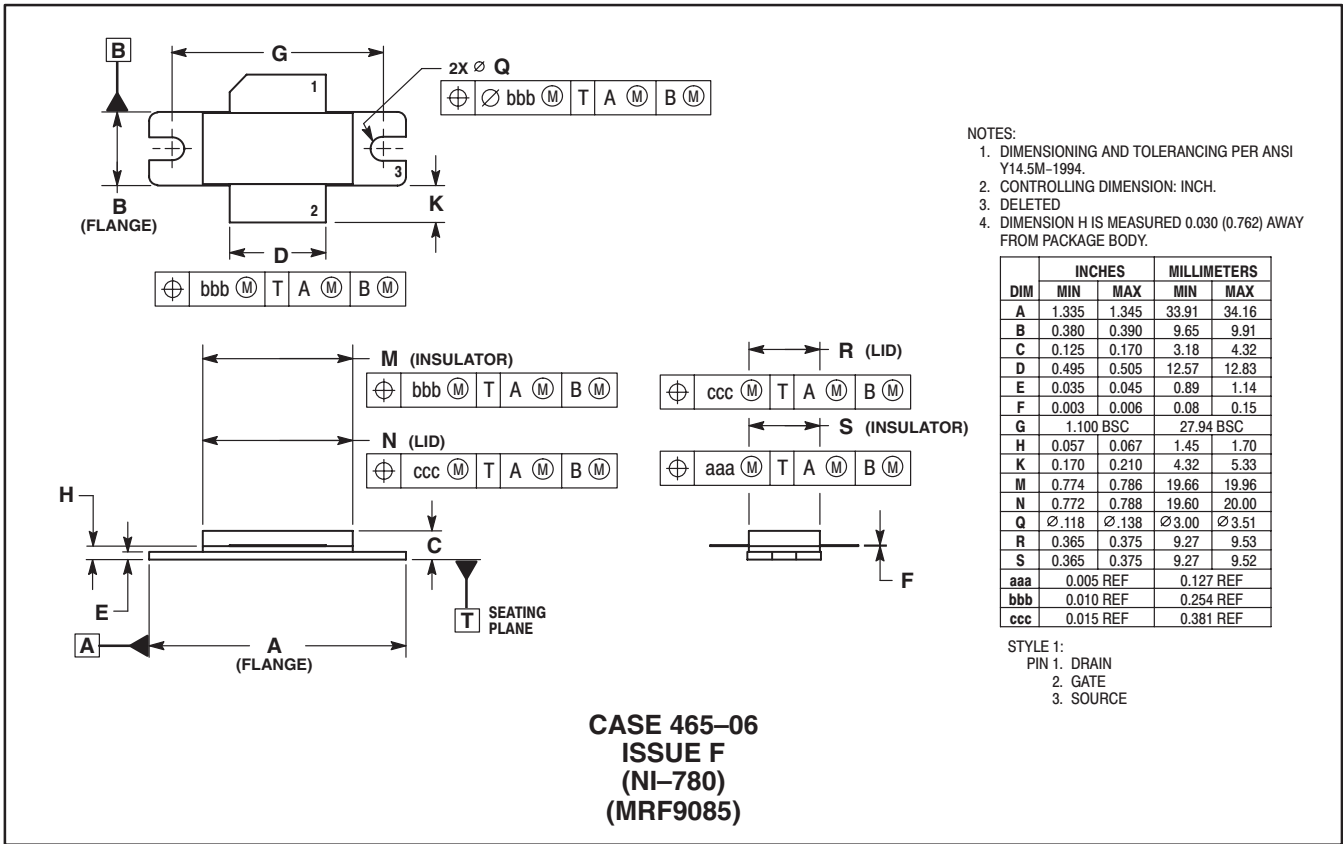



Figure 8. Series Equivalent Input and Output Impedance

PACKAGE DIMENSIONS



Motorola reserves the right to make changes without further notice to any products herein. Motorola makes no warranty, representation or guarantee regarding the suitability of its products for any particular purpose, nor does Motorola assume any liability arising out of the application or use of any product or circuit, and specifically disclaims any and all liability, including without limitation consequential or incidental damages. "Typical" parameters which may be provided in Motorola data sheets and/or specifications can and do vary in different applications and actual performance may vary over time. All operating parameters, including "Typicals" must be validated for each customer application by customer's technical experts. Motorola does not convey any license under its patent rights nor the rights of others. Motorola products are not designed, intended, or authorized for use as components in systems intended for surgical implant into the body, or other applications intended to support or sustain life, or for any other application in which the failure of the Motorola product could create a situation where personal injury or death may occur. Should Buyer purchase or use Motorola products for any such unintended or unauthorized application, Buyer shall indemnify and hold Motorola and its officers, employees, subsidiaries, affiliates, and distributors harmless against all claims, costs, damages, and expenses, and reasonable attorney fees arising out of, directly or indirectly, any claim of personal injury or death associated with such unintended or unauthorized use, even if such claim alleges that Motorola was negligent regarding the design or manufacture of the part. Motorola, Inc. Motorola, Inc. is an Equal Opportunity/Affirmative Action Employer. MOTOROLA and the  logo are registered in the US Patent & Trademark Office. All other product or service names are the property of their respective owners.

© Motorola, Inc. 2002.

How to reach us:

USA/EUROPE/Locations Not Listed: Motorola Literature Distribution; P.O. Box 5405, Denver, Colorado 80217. 1-303-675-2140 or 1-800-441-2447

JAPAN: Motorola Japan Ltd.; SPS, Technical Information Center, 3-20-1, Minami-Azabu. Minato-ku, Tokyo 106-8573 Japan. 81-3-3440-3569

ASIA/PACIFIC: Motorola Semiconductors H.K. Ltd.; Silicon Harbour Centre, 2 Dai King Street, Tai Po Industrial Estate, Tai Po, N.T., Hong Kong. 852-26668334

Technical Information Center: 1-800-521-6274

HOME PAGE: <http://www.motorola.com/semiconductors/>



This datasheet has been download from:

www.datasheetcatalog.com

Datasheets for electronics components.