

材质及电镀		MATERIAL	
间距	5.0mm	Pitch	5.0mm
极数	2p、3p	Poles	2p、3p
塑件	PBT,UL94V-0	Housing	PBT,UL94V-0
螺丝	M2.5、钢、镀锌	Screw	M2.5、Steel、Zinc plated
触点材料	磷青铜、镀镍、不锈钢	Contact	Phosphor bronze Ni plated stainless steel
焊针	黄铜、镀锡	Pin header:	Brass、Tin plated
电气性能		ELECTRICAL	
额定电压	300V	Rated voltage	300V
额定电流	16A	Rated current	16A
耐电压	AC1500V/Min	Withstanding voltage	AC1500V/Min
使用线径	22-14A WG	Wire range	22-14A WG
机械性能		MECHANICAL	
温度范围	-40°C to +125°C	Temperature range	-40°C to +125°C
瞬间温度	+250°C5秒	MAX soldering	+250°C5 secratgry
扭矩	0.5Nm(4.4lb.in)	Torque	0.5Nm(4.4lb.in)
剥线长度	4.5-5mm	Strip length	4.5-5mm

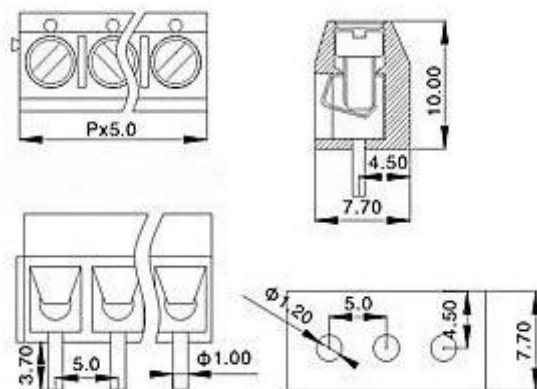

宁波森昱电子有限公司
GX301-5.0PDF资料