

2.4-GHz RF Front End

FEATURES

- Seamless Interface to 2.4-GHz Low Power RF Devices from Texas Instruments
- Up to 22-dBm Output Power
- 6-dB Typical Improved Sensitivity on CC24xx and CC2500, CC2510, and CC2511
- Few External Components
 - Integrated Switches
 - Integrated Matching Network
 - Integrated Balun
 - Integrated Inductors
 - Integrated PA
 - Integrated LNA
- Digital Control of LNA Gain by HGM Pin
- 100-nA in Power Down (EN = PAEN = 0)
- Low Transmit Current Consumption (100-mA at 3-V for 20-dBm Out, PAE = 33%)
- Low Receive Current Consumption
 - 3.4-mA for High Gain Mode
 - 1.7-mA for Low Gain Mode
- 4.8-dB LNA Noise Figure, including T/R Switch and external antenna match
- RoHS Compliant 4x4-mm QFN-16 Package
- 2-V to 3.6-V Operation

APPLICATIONS

- All 2.4-GHz ISM Band Systems
- Wireless Sensor Networks
- Wireless Industrial Systems
- IEEE 802.15.4 and ZigBee Systems
- Wireless Consumer Systems
- Wireless Audio Systems

DESCRIPTION

CC2591 is a cost-effective and high performance RF Front End for low-power and low-voltage 2.4-GHz wireless applications.

CC2591 is a range extender for all existing and future 2.4-GHz low-power RF transceivers, transmitters and System-on-Chip products from Texas Instruments.

CC2591 increases the link budget by providing a power amplifier for increased output power, and an LNA with low noise figure for improved receiver sensitivity.

CC2591 provides a small size, high output power RF design with its 4x4-mm QFN-16 package.

CC2591 contains PA, LNA, switches, RF-matching, and balun for simple design of high performance wireless applications.

CC2591 BLOCK DIAGRAM

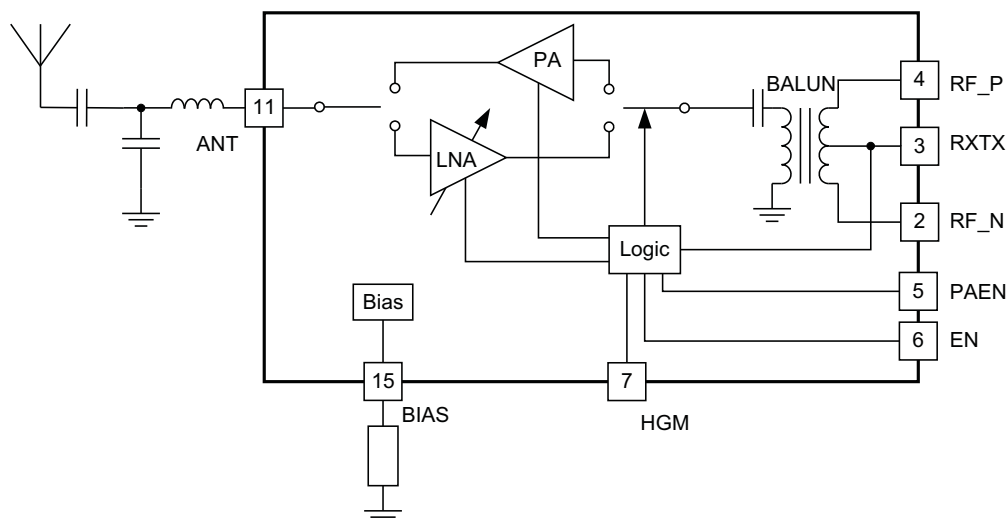

Please be aware that an important notice concerning availability, standard warranty, and use in critical applications of Texas Instruments semiconductor products and disclaimers thereto appears at the end of this data sheet.



These devices have limited built-in ESD protection. The leads should be shorted together or the device placed in conductive foam during storage or handling to prevent electrostatic damage to the MOS gates.

ABSOLUTE MAXIMUM RATINGS

Under no circumstances must the absolute maximum ratings be violated. Stress exceeding one or more of the limiting values may cause permanent damage to the device.

PARAMETER		VALUE	UNIT
Supply voltage	All supply pins must have the same voltage	–0.3 to 3.6	V
Voltage on any digital pin		–0.3 to $V_{DD} + 0.3$, max 3.6	
Input RF level		10	dBm
Storage temperature range		–50 to 150	°C

RECOMMENDED OPERATING CONDITIONS

The operating conditions for CC2591 are listed below.

PARAMETER		MIN	MAX	UNIT
Ambient temperature range		–40	85	°C
Operating supply voltage		2	3.6	V
Operating frequency range		2400	2483.5	MHz

ELECTRICAL CHARACTERISTICS

$T_C = 25^\circ\text{C}$, $V_{DD} = 3\text{ V}$, $f_{RF} = 2440\text{MHz}$ (unless otherwise noted). Measured on CC2591EM reference design including external matching components.

PARAMETER	TEST CONDITIONS	MIN	TYP	MAX	UNIT
Receive current, High Gain Mode	HGM = 1		3.4	4	mA
Receive current, Low Gain Mode	HGM = 0		1.7	2	
Transmit current	$P_{IN} = 0.5\text{ dBm}$		112		
Transmit current	No input signal		40	50	
Power down current	EN = PAEN = 0		0.1	0.3	μA
High input level (control pins)	EN, PAEN, HGM, RXTX	1.3		V_{DD}	V
Low input level (control pins)	EN, PAEN, HGM, RXTX			0.3	
Power down - Receive mode switching time			12		μs
Power down - Transmit mode switching time			1		μs
RF Receive					
Gain, High Gain Mode	HGM = 1		11		dB
Gain, Low Gain Mode	HGM = 0		1		dB
Gain variation, 2400 – 2483.5 MHz, High Gain Mode	HGM = 1		1.3		dB
Gain variation, 2.0V – 3.6V, High Gain Mode	HGM = 1		1.5		dB
Gain variation, $-40^\circ\text{C} - 85^\circ\text{C}$, High Gain Mode	HGM = 1		3		dB
Noise figure, High Gain Mode	HGM = 1, including internal T/R switch and external antenna match		4.8		dB
Input 1 dB compression, High Gain Mode	HGM = 1		–17		dBm
Input IP3, High Gain Mode	HGM = 1		–2		dBm
Input reflection coefficient, S11	HGM = 1, measured at antenna port		–11		dB

ELECTRICAL CHARACTERISTICS (continued)

$T_C = 25^\circ\text{C}$, $V_{DD} = 3\text{ V}$, $f_{RF} = 2440\text{MHz}$ (unless otherwise noted). Measured on CC2591EM reference design including external matching components.

PARAMETER	TEST CONDITIONS	MIN	TYP	MAX	UNIT
RF Transmit					
Gain			22		dB
Output power, P_{OUT}	$P_{IN} = 0.5\text{ dBm}$		20.6		dBm
Maximum output power	$P_{IN} = 5\text{ dBm}$		22		dBm
Power Added Efficiency, PAE	$P_{IN} = 0.5\text{ dBm}$		34%		
Output 1 dB compression			19		dBm
Output IP3			32		dBm
Output power variation over frequency	2400 – 2483.5 MHz, $P_{IN} = 0.5\text{ dBm}$		0.5		dB
Output power variation over power supply	2V – 3.6V, $P_{IN} = 0.5\text{ dBm}$		3.5		dB
Output power variation over temperature	$-40^\circ\text{C} - 85^\circ\text{C}$, $P_{IN} = 0.5\text{ dBm}$		1.5		dB
2nd harmonic power	$P_{IN} = 0.5\text{ dBm}$. The 2nd harmonic can be reduced to below regulatory limits by using an external LC filter and antenna.		-15		dBm
3rd harmonic power	$P_{IN} = 0.5\text{ dBm}$. The 3rd harmonic can be reduced to below regulatory limits by using an external LC filter and antenna.		-30		dBm

EEPW.com.cn 电子产品网

DEVICE INFORMATION

The CC2591 pinout and description are shown in Figure 1 and Table 1, respectively.

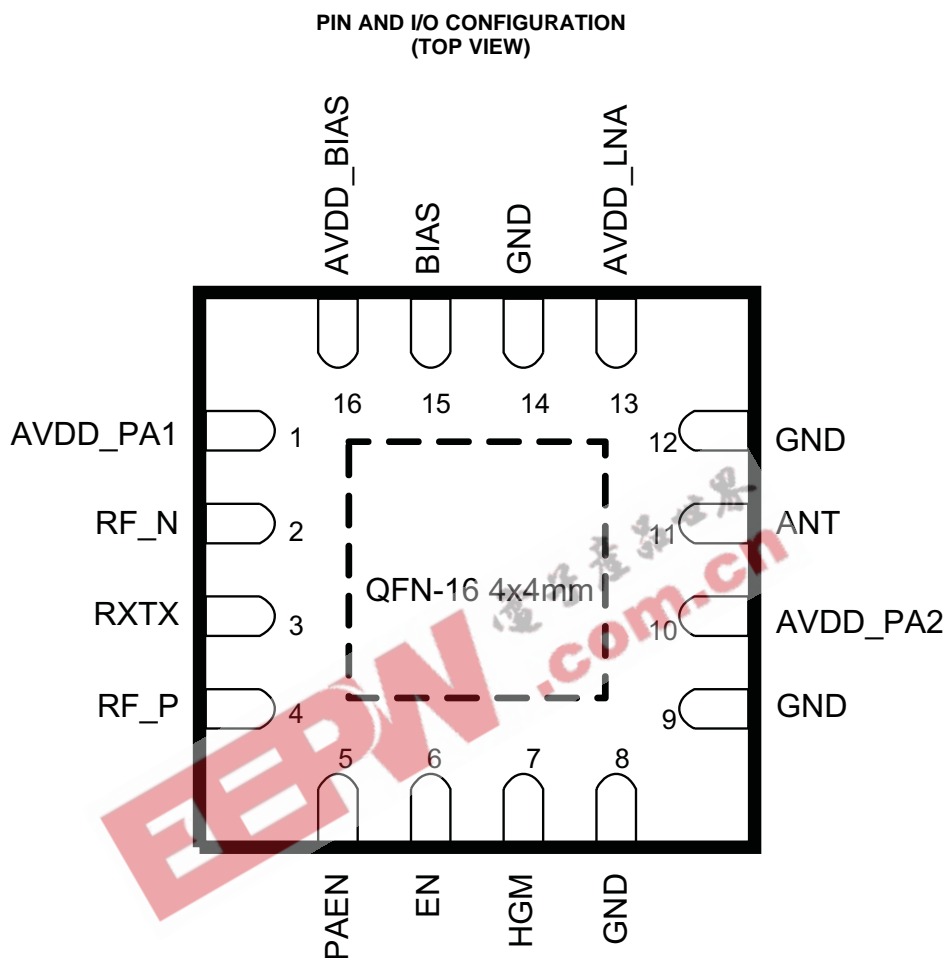

Figure 1.

NOTE:

The exposed die attach pad **must** be connected to a solid ground plane as this is the primary ground connection for the chip. Inductance in vias to the pad should be minimized. It is highly recommended to follow the reference layout. Changes will alter the performance. Also see the PCB landpattern information in this data sheet.

For best performance, minimize the length of the ground vias, by using a 4-layer PCB with ground plane as layer 2 when CC2591 is mounted onto layer 1.

Table 1. TERMINAL FUNCTIONS

TERMINAL		TYPE	DESCRIPTION
NO.	NAME		
—	GND	Ground	The exposed die attach pad must be connected to a solid ground plane. See CC2591EM reference design for recommended layout.
1	AVDD_PA1	Power	2.0 V – 3.6 V Power. PCB trace to this pin serves as inductive load to PA . See CC2591EM reference design for recommended layout.
2	RF_N	RF	RF interface towards CC24xx or CC25xx device.
3	RXTX	Analog/Control	RXTX switching voltage when connected to CC24xx devices. See Table 3 and Table 4 for details.
4	RF_P	RF	RF interface towards CC24xx or CC25xx device
5	PAEN	Digital Input	Digital control pin. See Table 3 and Table 4 for details.
6	EN	Digital Input	Digital control pin. See Table 3 and Table 4 for details.
7	HGM	Digital Input	Digital control pin. HGM=1 → Device in High Gain Mode HGM=0 → Device in Low Gain Mode (RX only)
8, 9, 12, 14	GND	Ground	Secondary ground connections. Should be shorted to the die attach pad on the top PCB layer.
10	AVDD_PA2	Power	2.0 V – 3.6 V Power. PCB trace to this pin serves as inductive load to PA. See CC2591EM reference design for recommended layout.
11	ANT	RF	Antenna interface.
13	AVDD_LNA	Power	2 V – 3.6 V Power. PCB trace to this pin serves as inductive load to LNA. See CC2591EM reference design for recommended layout.
15	BIAS	Analog	Biasing input. Resistor between this node and ground sets bias current to PAs.
16	AVDD_BIAS	Power	2 V – 3.6 V Power.

CC2591EM Evaluation Module

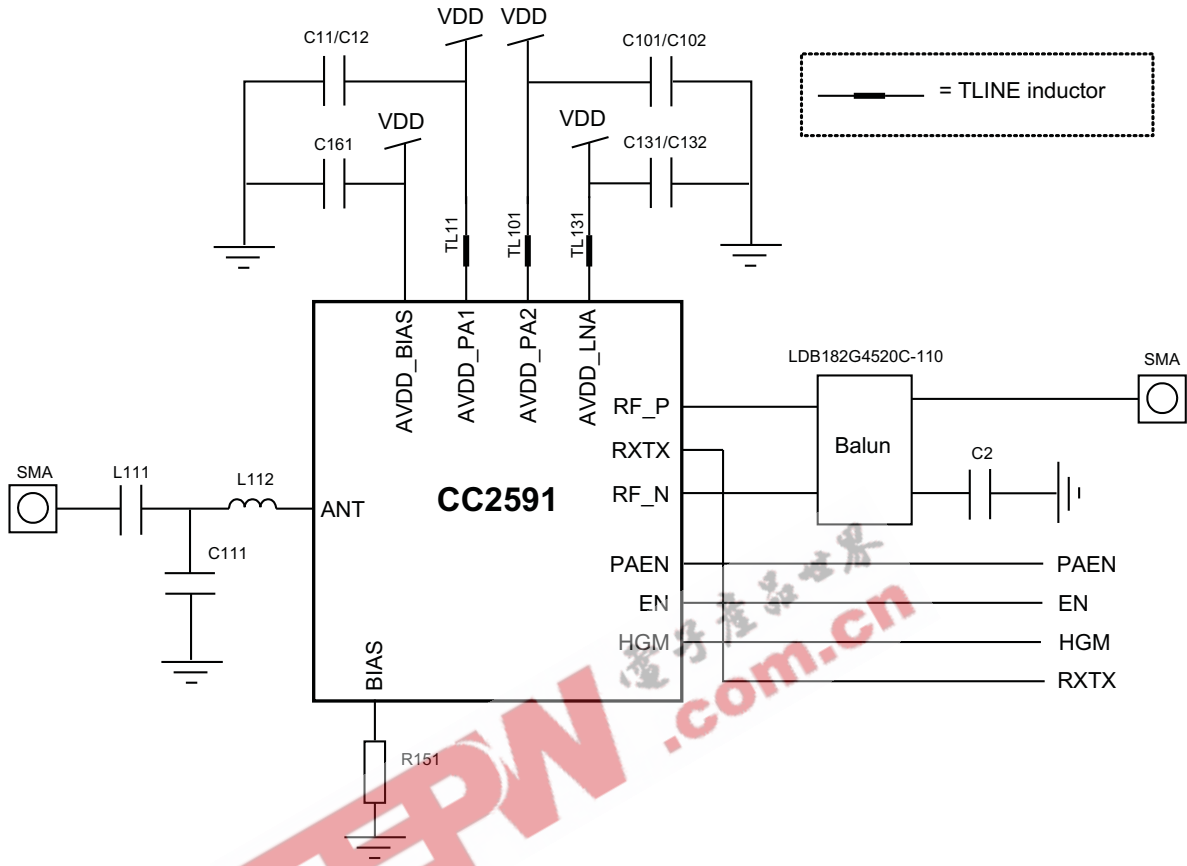

Figure 2. CC2591EM Evaluation Module

Table 2. List of Materials (See CC2591EM Reference Design)

DEVICE	FUNCTION	VALUE
L112	Part of antenna match.	1.5 nH: LQW15AN1N5B00 from Murata
L111	DC block.	1 nF: GRM1555C1H102JA01 from Murata
C111	Part of antenna match.	1 pF: GRM1555C1H1R0BZ01 from Murata
C161	Decoupling capacitor.	1 nF: GRM1555C1H102JA01 from Murata
C11/C12	Decoupling. Will affect PA resonance.	10 pF 1 nF. The smallest cap closest. See CC2591EM reference design for placement. 10 pF: GRM1555C1H100JZ01 from Murata 1 nF: GRM1555C1H102JA01 from Murata
C101/C102	Decoupling. Will affect PA resonance.	18 pF 1 nF. The smallest cap closest. See for CC2591EM reference design placement. 18 pF: GRM1555C1H180JZ01 from Murata 1 nF: GRM1555C1H102JA01 from Murata
C131/C132	Decoupling. Will affect PA resonance.	10 pF 1 nF. The smallest cap closest. See CC2591EM reference design for placement. 10 pF: GRM1555C1H100JZ01 from Murata 1 nF: GRM1555C1H102JA01 from Murata
C2	Decoupling of external balun	1 nF: GRM1555C1H102JA01 from Murata
TL11	Transmission line. Will affect PA resonance.	See CC2591EM reference design.
TL101	Transmission line. Will affect PA resonance.	See CC2591EM reference design.
TL131	Transmission line. Will affect LNA resonance.	See CC2591EM reference design.
R151	Bias resistor	4.3 kΩ: RK73H1ETTP4301F from Koa

TYPICAL CHARACTERISTICS

LNA GAIN AND NOISE FIGURE vs FREQUENCY

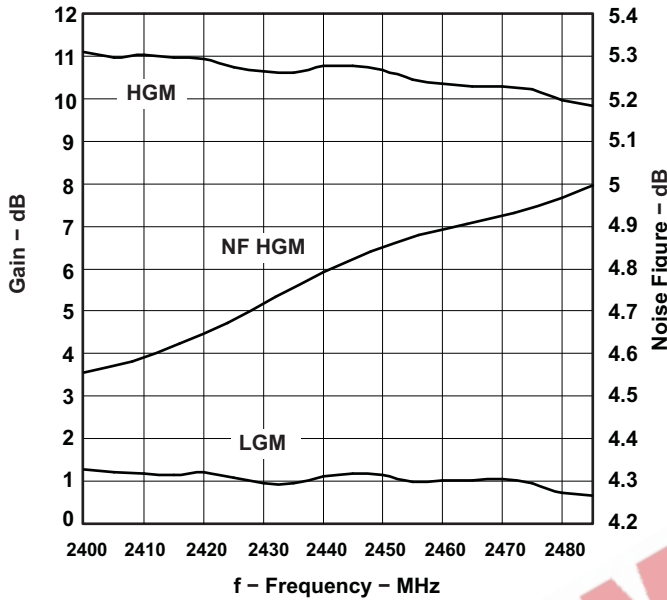

Figure 3.

LNA GAIN vs TEMPERATURE

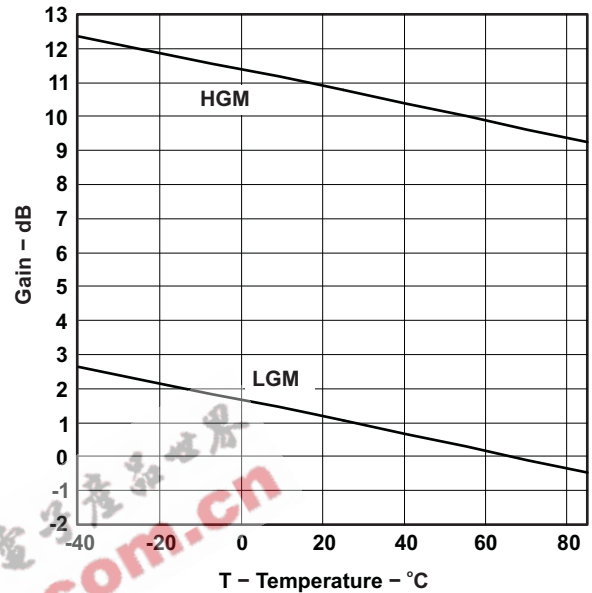

Figure 4.

LNA GAIN vs POWER SUPPLY

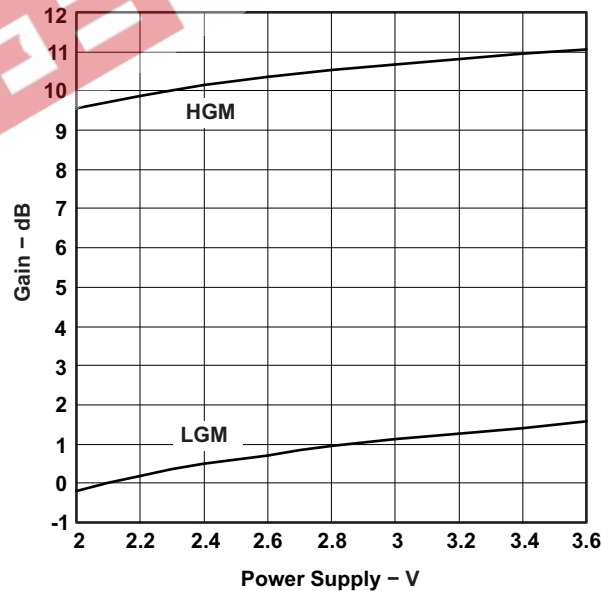

Figure 5.

TYPICAL CHARACTERISTICS (continued)

OUTPUT POWER, PAE AND CURRENT CONSUMPTION VS INPUT POWER

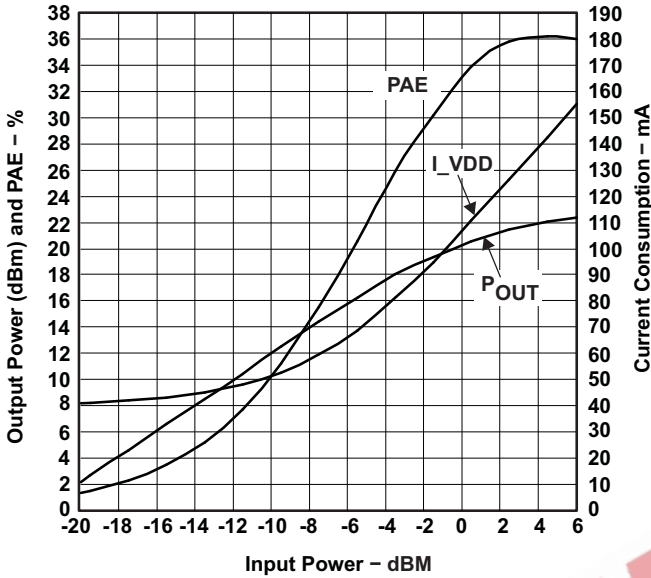

Figure 6.

OUTPUT POWER, PAE AND CURRENT CONSUMPTION VS FREQUENCY

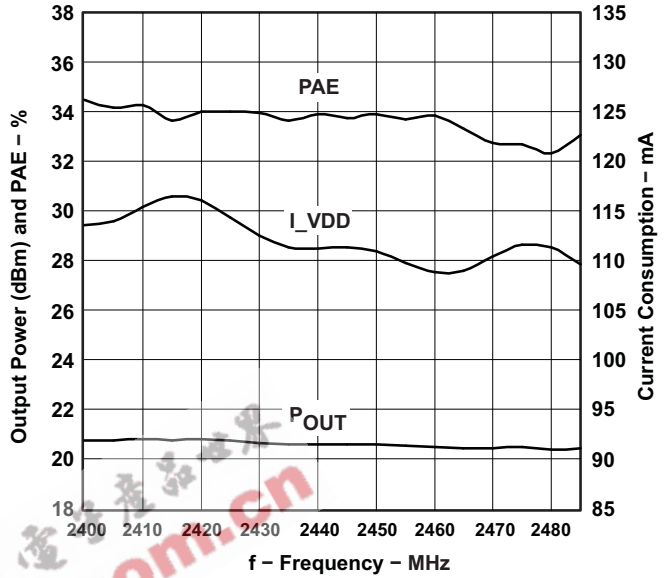

Figure 7.

OUTPUT POWER, PAE AND CURRENT CONSUMPTION VS TEMPERATURE

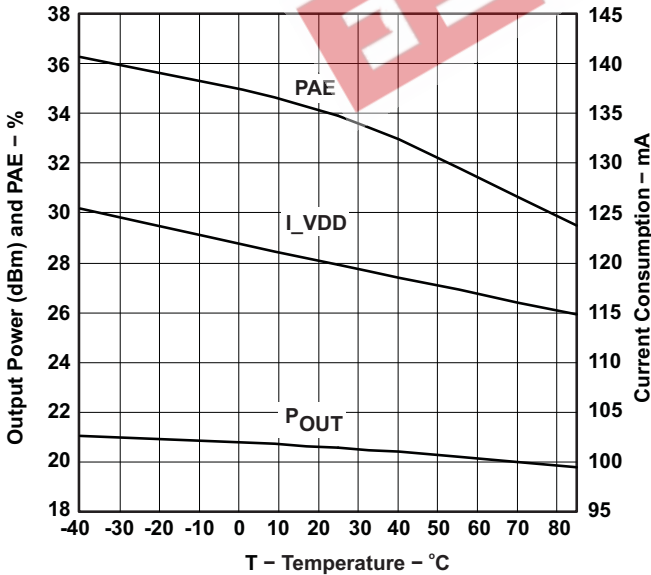

Figure 8.

OUTPUT POWER, PAE AND CURRENT CONSUMPTION VS POWER SUPPLY

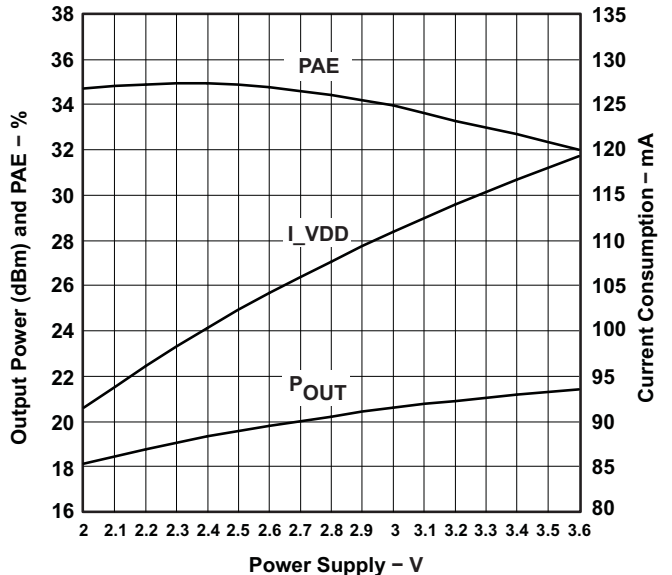

Figure 9.

Controlling the Output Power from CC2591

The output power of CC2591 is controlled by controlling the input power. The CC2591 PA is designed to work in compression (class AB), and the best efficiency is reached when a strong input signal is applied.

Input Levels on Control Pins

The four digital control pins (PAEN, EN, HGM, RXTX) have built-in level-shifting functionality, meaning that if the CC2591 is operating from a 3.6-V supply voltage, the control pins will still sense 1.6-V - 1.8-V signals as logical '1'.

An example of the above would be that RXTX is connected directly to the RXTX pin on CC24xx, but the global supply voltage is 3.6 V. The RXTX pin on CC24xx will switch between 0 V (RX) and 1.8 V(TX), which is still a high enough voltage to control the mode of CC2591.

The input voltages should however not have logical '1' level that is higher than the supply.

Connecting CC2591 to a CC24xx Device

Table 3. Control Logic for Connecting CC2591 to a CC24xx Device

PAEN = EN	RXTX	HGM	MODE OF OPERATION
0	X	X	Power Down
1	0	0	RX Low Gain Mode
1	0	1	RX High Gain Mode
1	1	X	TX

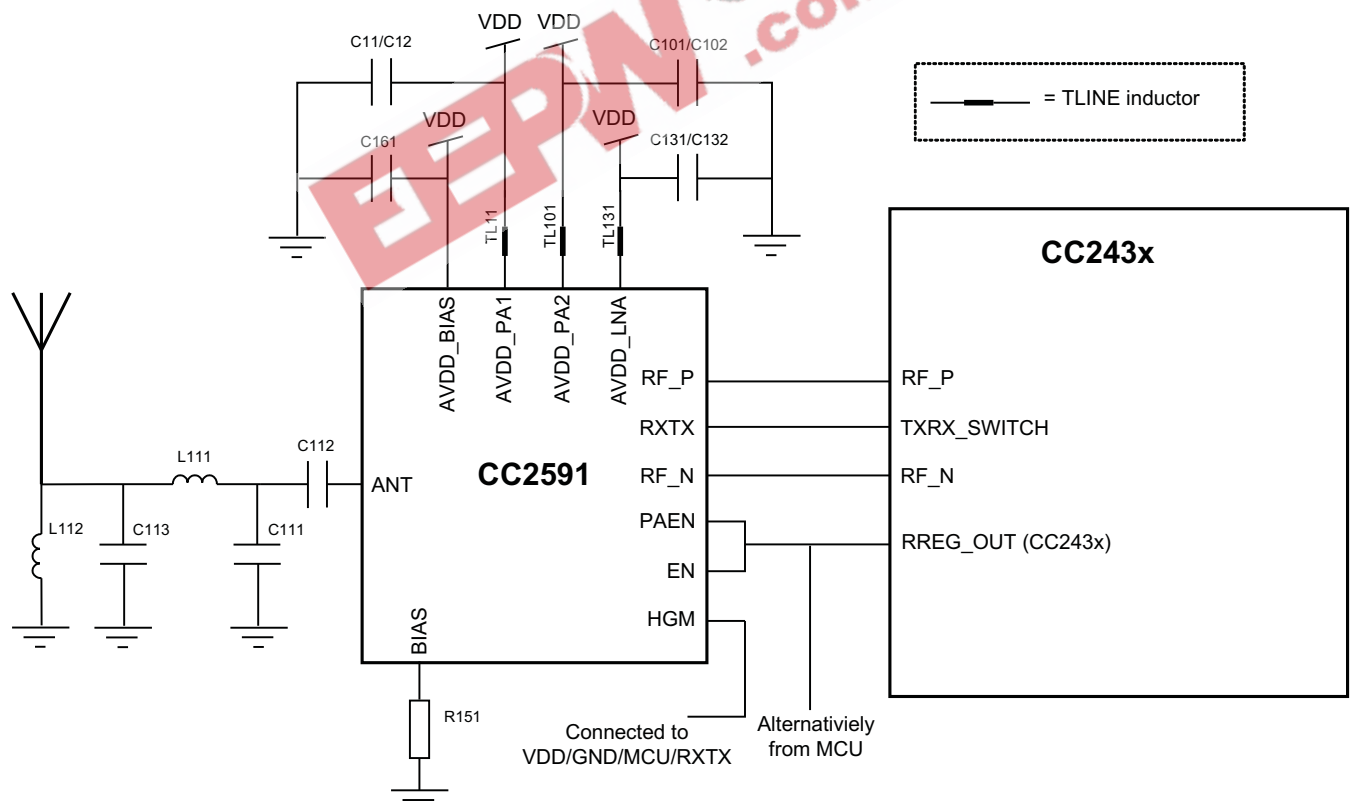

Figure 10. CC2591 + CC24xx Application Circuit

Connecting CC2591 to the CC2500, CC2510, or CC2511 Device

Table 4. Control Logic for Connecting CC2591 to a CC2500/10/11 Devices

PAEN	EN	RXTX	HGM	MODE OF OPERATION
0	0	NC	X	Power Down
0	1	NC	0	RX LGM
0	1	NC	1	RX HGM
1	0	NC	X	TX
1	1	NC	X	Not allowed

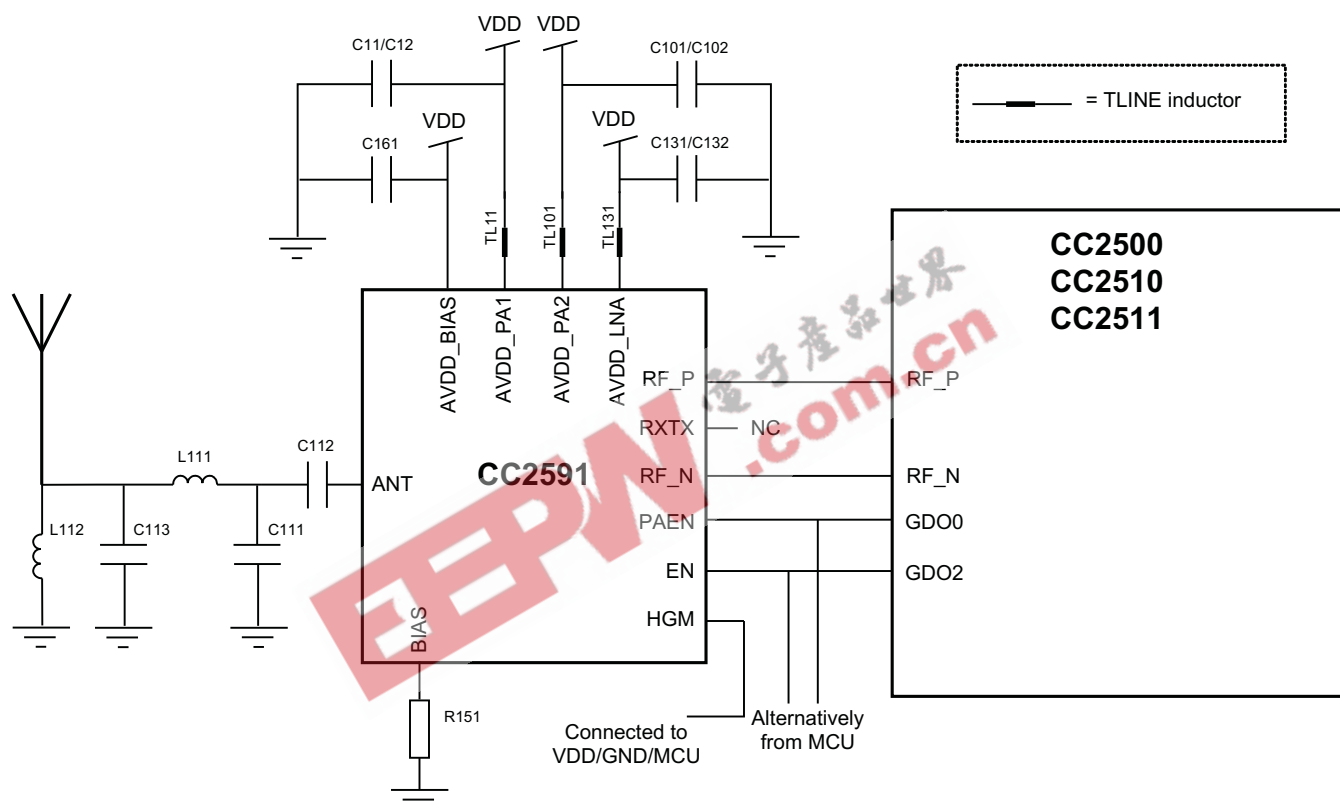

Figure 11. CC2591 + CC2500/10/11 Device Application Circuit

PACKAGING INFORMATION

Orderable Device	Status ⁽¹⁾	Package Type	Package Drawing	Pins	Package Qty	Eco Plan ⁽²⁾	Lead/Ball Finish	MSL Peak Temp ⁽³⁾
CC2591RGVR	ACTIVE	QFN	RGV	16	2500	Green (RoHS & no Sb/Br)	Call TI	Level-2-260C-1 YEAR
CC2591RGVT	ACTIVE	QFN	RGV	16	250	Green (RoHS & no Sb/Br)	Call TI	Level-2-260C-1 YEAR

⁽¹⁾ The marketing status values are defined as follows:

ACTIVE: Product device recommended for new designs.

LIFEBUY: TI has announced that the device will be discontinued, and a lifetime-buy period is in effect.

NRND: Not recommended for new designs. Device is in production to support existing customers, but TI does not recommend using this part in a new design.

PREVIEW: Device has been announced but is not in production. Samples may or may not be available.

OBSOLETE: TI has discontinued the production of the device.

⁽²⁾ Eco Plan - The planned eco-friendly classification: Pb-Free (RoHS), Pb-Free (RoHS Exempt), or Green (RoHS & no Sb/Br) - please check <http://www.ti.com/productcontent> for the latest availability information and additional product content details.

TBD: The Pb-Free/Green conversion plan has not been defined.

Pb-Free (RoHS): TI's terms "Lead-Free" or "Pb-Free" mean semiconductor products that are compatible with the current RoHS requirements for all 6 substances, including the requirement that lead not exceed 0.1% by weight in homogeneous materials. Where designed to be soldered at high temperatures, TI Pb-Free products are suitable for use in specified lead-free processes.

Pb-Free (RoHS Exempt): This component has a RoHS exemption for either 1) lead-based flip-chip solder bumps used between the die and package, or 2) lead-based die adhesive used between the die and leadframe. The component is otherwise considered Pb-Free (RoHS compatible) as defined above.

Green (RoHS & no Sb/Br): TI defines "Green" to mean Pb-Free (RoHS compatible), and free of Bromine (Br) and Antimony (Sb) based flame retardants (Br or Sb do not exceed 0.1% by weight in homogeneous material)

⁽³⁾ MSL, Peak Temp. -- The Moisture Sensitivity Level rating according to the JEDEC industry standard classifications, and peak solder temperature.

Important Information and Disclaimer: The information provided on this page represents TI's knowledge and belief as of the date that it is provided. TI bases its knowledge and belief on information provided by third parties, and makes no representation or warranty as to the accuracy of such information. Efforts are underway to better integrate information from third parties. TI has taken and continues to take reasonable steps to provide representative and accurate information but may not have conducted destructive testing or chemical analysis on incoming materials and chemicals. TI and TI suppliers consider certain information to be proprietary, and thus CAS numbers and other limited information may not be available for release.

In no event shall TI's liability arising out of such information exceed the total purchase price of the TI part(s) at issue in this document sold by TI to Customer on an annual basis.

TAPE AND REEL INFORMATION

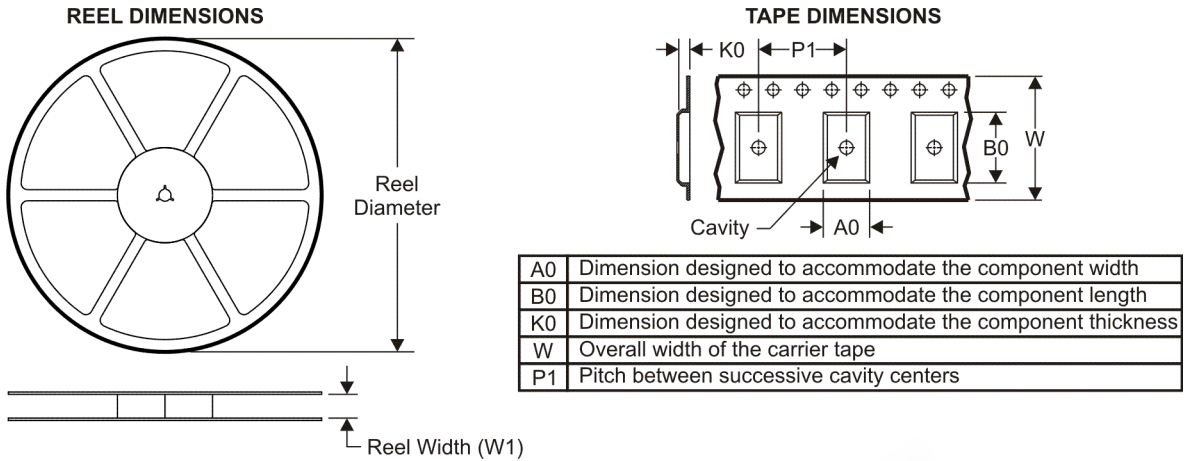

QUADRANT ASSIGNMENTS FOR PIN 1 ORIENTATION IN TAPE

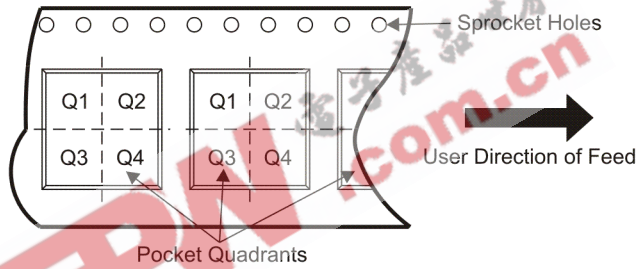

*All dimensions are nominal

Device	Package Type	Package Drawing	Pins	SPQ	Reel Diameter (mm)	Reel Width W1 (mm)	A0 (mm)	B0 (mm)	K0 (mm)	P1 (mm)	W (mm)	Pin1 Quadra
CC2591RGVR	QFN	RGV	16	2500	330.0	12.4	4.3	4.3	1.5	8.0	12.0	Q2
CC2591RGVT	QFN	RGV	16	250	330.0	12.4	4.3	4.3	1.5	8.0	12.0	Q2

TAPE AND REEL BOX DIMENSIONS

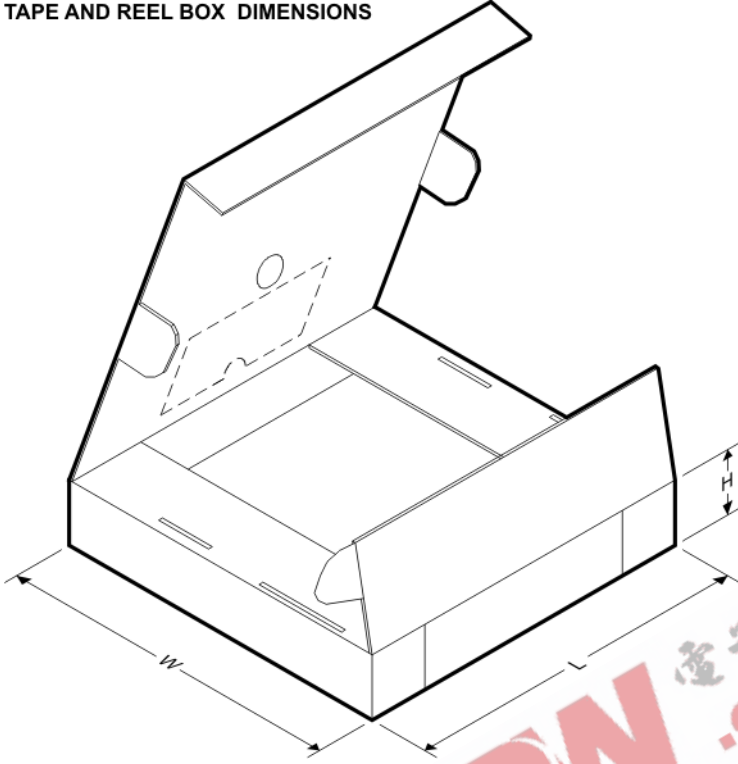

*All dimensions are nominal

Device	Package Type	Package Drawing	Pins	SPQ	Length (mm)	Width (mm)	Height (mm)
CC2591RGVR	QFN	RGV	16	2500	340.5	333.0	20.6
CC2591RGVT	QFN	RGV	16	250	340.5	333.0	20.6

THERMAL INFORMATION

This package incorporates an exposed thermal pad that is designed to be attached directly to an external heatsink. The thermal pad must be soldered directly to the printed circuit board (PCB). After soldering, the PCB can be used as a heatsink. In addition, through the use of thermal vias, the thermal pad can be attached directly to the appropriate copper plane shown in the electrical schematic for the device, or alternatively, can be attached to a special heatsink structure designed into the PCB. This design optimizes the heat transfer from the integrated circuit (IC).

For information on the Quad Flatpack No-Lead (QFN) package and its advantages, refer to Application Report, Quad Flatpack No-Lead Logic Packages, Texas Instruments Literature No. SCBA017. This document is available at www.ti.com.

The exposed thermal pad dimensions for this package are shown in the following illustration.

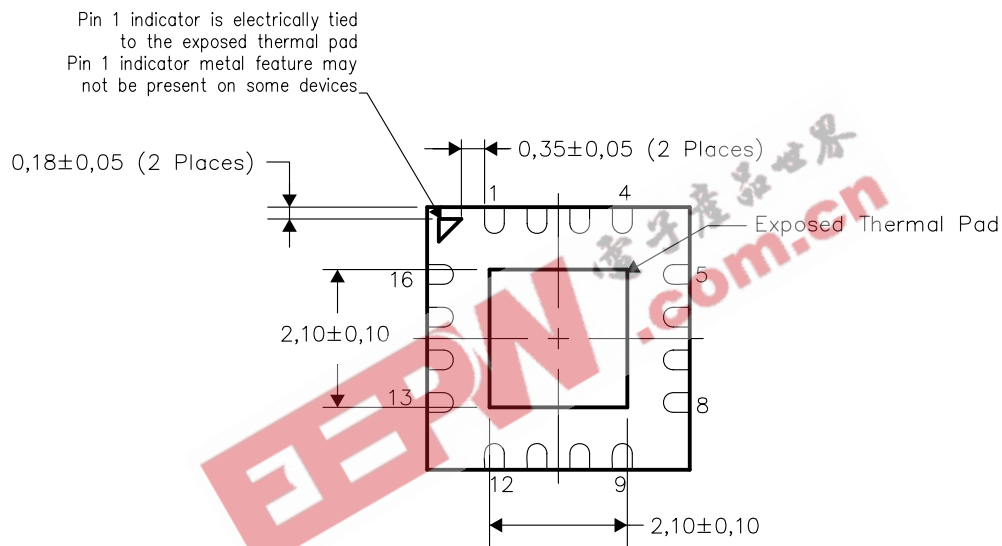

Bottom View

NOTE: All linear dimensions are in millimeters

Exposed Thermal Pad Dimensions

RGV (S-PQFP-N16)

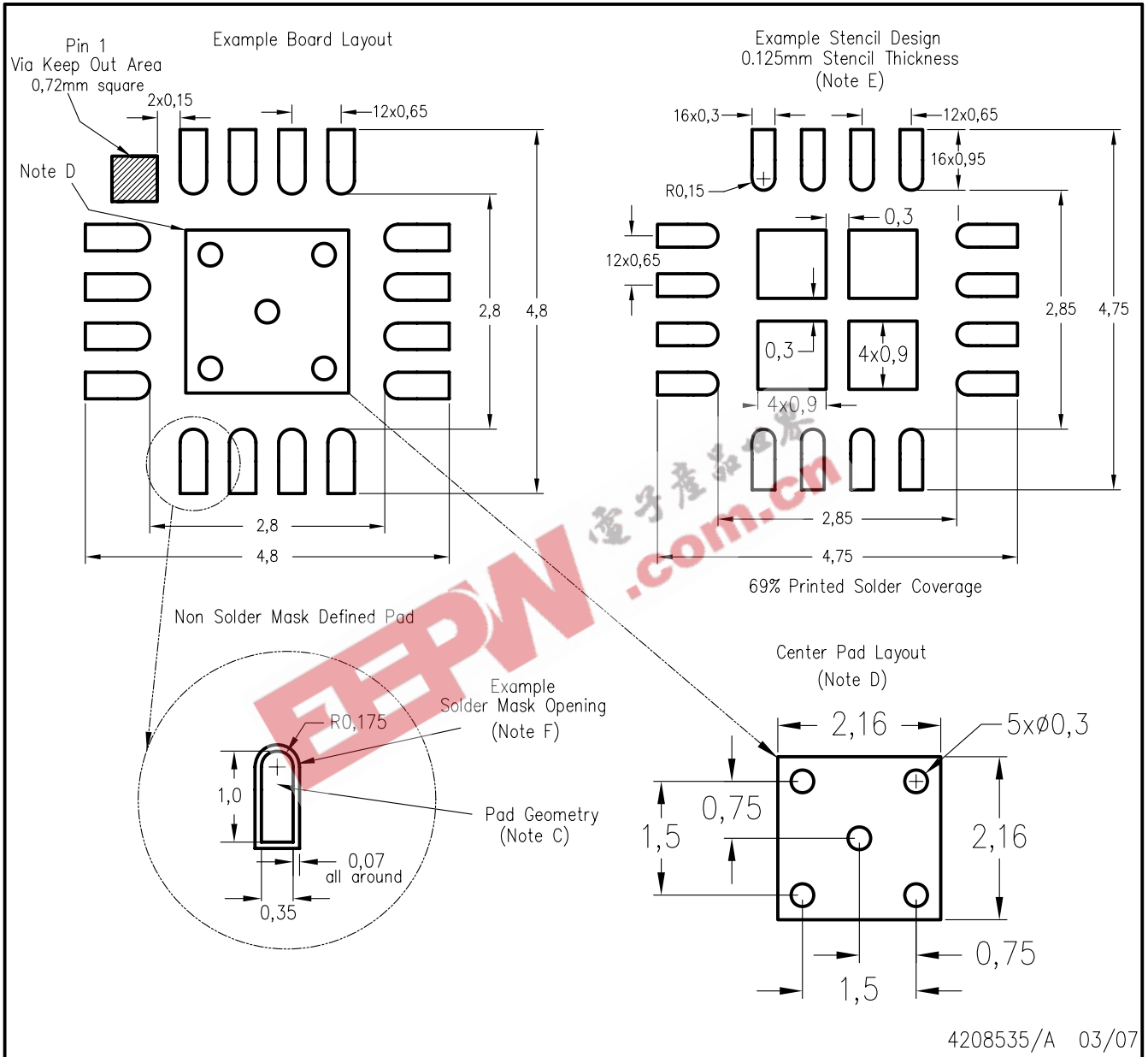

4208535/A 03/07

- NOTES:
- All linear dimensions are in millimeters.
 - This drawing is subject to change without notice.
 - Publication IPC-7351 is recommended for alternate designs.
 - This package is designed to be soldered to a thermal pad on the board. Refer to Application Note, QFN Packages, Texas Instruments Literature No. SCBA017, SLUA271, and also the Product Data Sheets for specific thermal information, via requirements, and recommended board layout. These documents are available at www.ti.com <<http://www.ti.com>>.
 - Laser cutting apertures with trapezoidal walls and also rounding corners will offer better paste release. Customers should contact their board assembly site for stencil design recommendations. Refer to IPC 7525 for stencil design considerations.
 - Customers should contact their board fabrication site for solder mask tolerances.

IMPORTANT NOTICE

Texas Instruments Incorporated and its subsidiaries (TI) reserve the right to make corrections, modifications, enhancements, improvements, and other changes to its products and services at any time and to discontinue any product or service without notice. Customers should obtain the latest relevant information before placing orders and should verify that such information is current and complete. All products are sold subject to TI's terms and conditions of sale supplied at the time of order acknowledgment.

TI warrants performance of its hardware products to the specifications applicable at the time of sale in accordance with TI's standard warranty. Testing and other quality control techniques are used to the extent TI deems necessary to support this warranty. Except where mandated by government requirements, testing of all parameters of each product is not necessarily performed.

TI assumes no liability for applications assistance or customer product design. Customers are responsible for their products and applications using TI components. To minimize the risks associated with customer products and applications, customers should provide adequate design and operating safeguards.

TI does not warrant or represent that any license, either express or implied, is granted under any TI patent right, copyright, mask work right, or other TI intellectual property right relating to any combination, machine, or process in which TI products or services are used. Information published by TI regarding third-party products or services does not constitute a license from TI to use such products or services or a warranty or endorsement thereof. Use of such information may require a license from a third party under the patents or other intellectual property of the third party, or a license from TI under the patents or other intellectual property of TI.

Reproduction of TI information in TI data books or data sheets is permissible only if reproduction is without alteration and is accompanied by all associated warranties, conditions, limitations, and notices. Reproduction of this information with alteration is an unfair and deceptive business practice. TI is not responsible or liable for such altered documentation. Information of third parties may be subject to additional restrictions.

Resale of TI products or services with statements different from or beyond the parameters stated by TI for that product or service voids all express and any implied warranties for the associated TI product or service and is an unfair and deceptive business practice. TI is not responsible or liable for any such statements.

TI products are not authorized for use in safety-critical applications (such as life support) where a failure of the TI product would reasonably be expected to cause severe personal injury or death, unless officers of the parties have executed an agreement specifically governing such use. Buyers represent that they have all necessary expertise in the safety and regulatory ramifications of their applications, and acknowledge and agree that they are solely responsible for all legal, regulatory and safety-related requirements concerning their products and any use of TI products in such safety-critical applications, notwithstanding any applications-related information or support that may be provided by TI. Further, Buyers must fully indemnify TI and its representatives against any damages arising out of the use of TI products in such safety-critical applications.

TI products are neither designed nor intended for use in military/aerospace applications or environments unless the TI products are specifically designated by TI as military-grade or "enhanced plastic." Only products designated by TI as military-grade meet military specifications. Buyers acknowledge and agree that any such use of TI products which TI has not designated as military-grade is solely at the Buyer's risk, and that they are solely responsible for compliance with all legal and regulatory requirements in connection with such use.

TI products are neither designed nor intended for use in automotive applications or environments unless the specific TI products are designated by TI as compliant with ISO/TS 16949 requirements. Buyers acknowledge and agree that, if they use any non-designated products in automotive applications, TI will not be responsible for any failure to meet such requirements.

Following are URLs where you can obtain information on other Texas Instruments products and application solutions:

Products

Amplifiers	amplifier.ti.com
Data Converters	dataconverter.ti.com
DSP	dsp.ti.com
Clocks and Timers	www.ti.com/clocks
Interface	interface.ti.com
Logic	logic.ti.com
Power Mgmt	power.ti.com
Microcontrollers	microcontroller.ti.com
RFID	www.ti-rfid.com
RF/IF and ZigBee® Solutions	www.ti.com/lprf

Applications

Audio	www.ti.com/audio
Automotive	www.ti.com/automotive
Broadband	www.ti.com/broadband
Digital Control	www.ti.com/digitalcontrol
Medical	www.ti.com/medical
Military	www.ti.com/military
Optical Networking	www.ti.com/opticalnetwork
Security	www.ti.com/security
Telephony	www.ti.com/telephony
Video & Imaging	www.ti.com/video
Wireless	www.ti.com/wireless

Mailing Address: Texas Instruments, Post Office Box 655303, Dallas, Texas 75265
Copyright © 2008, Texas Instruments Incorporated