

材质及电镀

间距	5.0mm
极数	2p、3p
塑件	PA66.UL94V-0
螺丝	M2.5、钢、镀锌
触点材料	钢、镀锌、或黄铜、镀镍
焊针	黄铜、镀锡

电气性能

额定电压	300V
额定电流	15A
耐电压	AC2000V/Min
使用线径	24-12A WG

机械性能

温度范围	-40°C to +125°C
瞬间温度	+250°C5秒
扭矩	0.4Nm(3.5lb.in)
剥线长度	6-7mm

MATERIAL

Pitch	5.0mm
Poles	2p、3p
Housing	PA66.UL94V-0
Screw	M2.5、Steel、Zinc plated
Contact	Steel Zinc plated or Brass Ni plated
Pin header:	Brass、Tin plated

ELECTRICAL

Rated voltage	300V
Rated current	15A
Withstanding voltage	AC2000V/Min
Wire range	24-12A WG

MECHANICAL

Temperature range	-40°C to +125°C
MAX soldering	+250°C5 secratgry
Torque	0.4Nm(3.5lb.in)
Strip length	6-7mm

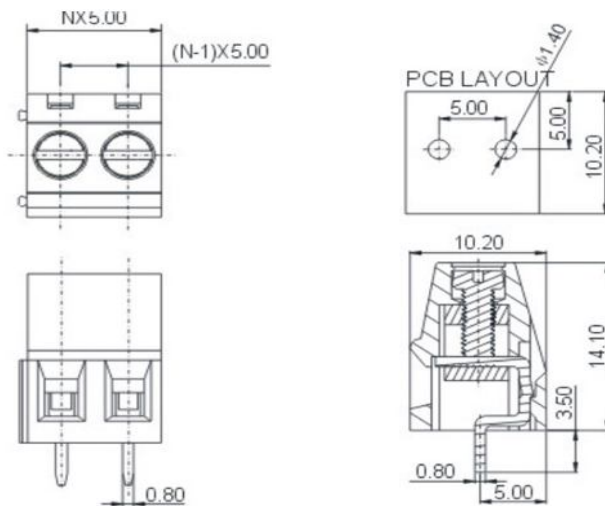

宁波森昱电子有限公司
GX128-5.0PDF资料