

Contents

1. Handling Precautions	3
2. General Description	4
2.1 General Specification.....	4
2.2 Optical Characteristics	5
3. Functional Block Diagram	10
4. Absolute Maximum Ratings	11
4.1 Absolute Ratings of TFT LCD Module	11
4.2 Absolute Ratings of Environment.....	11
5. Electrical Characteristics	12
5.1 TFT LCD Module	12
5.1.1 Power Specification	12
5.1.2 Signal Electrical Characteristics	13
5.2 Backlight Unit.....	15
5.2.1 LED characteristics.....	15
6. Signal Interface Characteristic	16
6.1 Pixel Format Image.....	16
6.2 Integration Interface Requirement	16
6.2.1 MIPI Connector Description.....	16
6.2.2 MIPI Pin Assignment	17
6.3 MIPI Interface Timing	18
6.4.1 Timing Characteristics	18
6.4 Power ON/OFF Sequence.....	18
7. Mechanical Characteristics	21
LCM Outline Dimension	21
7.1 Standard Front View.....	21
7.2 Standard Rear View.....	22
8. Shipping and Package	23
8.1 Carton Package	23
8.2 Shipping Package of Palletizing Sequence	24

1. Handling Precautions

- 1) Since front polarizer is easily damaged, pay attention not to scratch it.
- 2) Be sure to turn off power supply when inserting or disconnecting from input connector.
- 3) Wipe off water drop immediately. Long contact with water may cause discoloration or spots.
- 4) When the panel surface is soiled, wipe it with absorbent cotton or other soft cloth.
- 5) Since the panel is made of glass, it may break or crack if dropped or bumped on hard surface.
- 6) Since CMOS LSI is used in this module, take care of static electricity and insure human earth when handling.
- 7) Do not open nor modify the Module Assembly.
- 8) Do not press the reflector sheet at the back of the module to any directions.
- 9) At the insertion or removal of the Signal Interface Connector, be sure not to rotate nor tilt the Interface Connector of the TFT Module.
- 11) After installation of the TFT Module into an enclosure (Notebook PC Bezel, for example), do not twist nor bend the TFT Module even momentary. At designing the enclosure, it should be taken into consideration that no bending/twisting forces are applied to the TFT Module from outside. Otherwise the TFT Module may be damaged.
- 12) Small amount of materials having no flammability grade is used in the LCD module. The LCD module should be supplied by power complied with requirements of Limited Power Source (IEC60950 or UL1950), or be applied exemption.
- 13) Disconnecting power supply before handling LCD modules, it can prevent electric shock, DO NOT TOUCH the electrode parts, cables, connectors and LED circuit part of TFT module that a LED light bar build in as a light source of back light unit. It can prevent electrostatic breakdown.

2. General Description

B080XAN01 V0 is a Color Active Matrix Liquid Crystal Display composed of a TFT LCD panel, a driver circuit, and LED backlight system. The screen format is intended to support the 4:3 XGA, 768(H) x1024(V) screen and 262k colors (RGB 6-bits data driver) with LED backlight driving circuit. All input signals are MIPI interface compatible.

B080XAN01 V0 is designed for a display unit of notebook style personal computer and industrial machine.

2.1 General Specification

Items	Unit	Specifications
Screen Diagona	[mm]	199.68
Active Area	[mm]	119.808 (H) x 159.744(V)
Pixels H x V		768 x 3(RGB) x 1024
Pixel Pitch	[mm]	0.156 X 0.156
Pixel Format		R.G.B. Vertical Stripe
Display Mode		Normally Black
White Luminance (ILED=21.8mA) (Note: I_{LED} is LED current)	[cd/m ²]	400 typ. (5 points average)
Luminance Uniformity		0.75 min. (5 points)
Contrast Ratio		800 typ
Response Time	[ms]	25 typ /35 Max
Nominal Input Voltage VDD	[Volt]	+3.3 typ.
Power Consumption	[Watt]	Logic Power: 0.79W max @ white
		BLU Power: 1.518W max
Weight	[Grams]	70 max (65 typ) (Base Panel)



Product Specification

AU OPTRONICS CORPORATION

Physical Size (panel only)	[mm]		Min.	Typ.	Max.
		Length	170.92	171.07	171.37
		Width	128.75	129	129.25
		Thickness (W/O PCBA)	---	---	2.01
		Thickness (W/ PCBA)	---	---	4.81
Support Color		16.7M colors (RGB 6-bit)			
Temperature Range Operating Storage (Non-Operating)	[°C] [°C]	0 to +50 -20 to +60			
RoHS Compliance		RoHS Compliance			

2.2 Optical Characteristics

The optical characteristics are measured under stable conditions at 25°C (Room Temperature) :

Item	Symbol	Conditions	Min.	Typ.	Max.	Unit	Note
White Luminance $I_{LED}=21.8mA$		5 points average	---	400	---	cd/m ²	1, 4, 5.
Viewing Angle	θ_R	Horizontal (Right)	---	89	---	degree	4, 9
	θ_L	CR = 10 (Left)	---	89	---		
	ψ_H	Vertical (Upper)	---	89	---		
	ψ_L	CR = 10 (Lower)	---	89	---		
Luminance Uniformity	δ_{5P}	5 Points	0.75	---	---		1, 3, 4
Luminance Uniformity	δ_{13P}	13 Points	0.7				
Contrast Ratio	CR		---	800	---		4, 6
Cross talk	%		---	---	4		4, 7
Response Time	T_{RT}	Rising + Falling	---	25	35	msec	4, 8
	Red	Rx	0.575	0.605	0.635		
		Ry	0.315	0.345	0.375		
	Green	Gx	0.287	0.327	0.367		
		Gy	0.540	0.570	0.600		
	Blue	Bx	0.125	0.155	0.185		
		By	0.087	0.117	0.147		

	White	Wx	0.283	0.313	0.343		
		Wy	0.299	0.329	0.359		
NTSC		%	-	50	-		

Note 1: 5 points position (Ref: Active area)

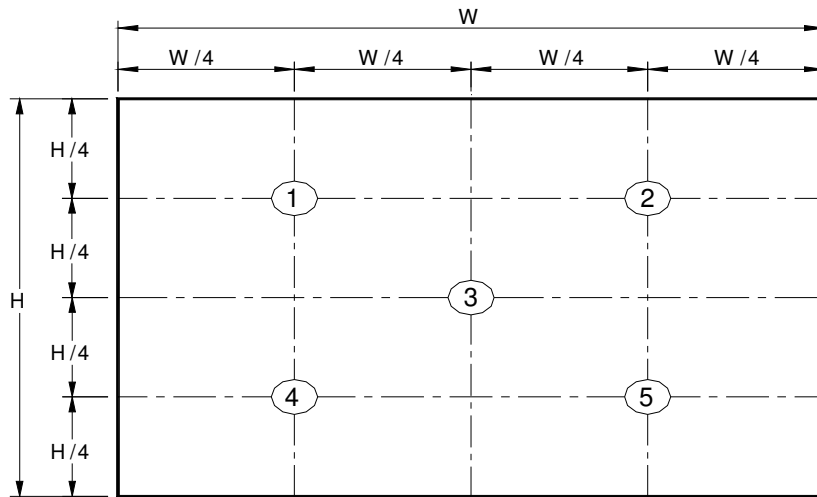

Note 2: 13 points position (Ref: Active area)

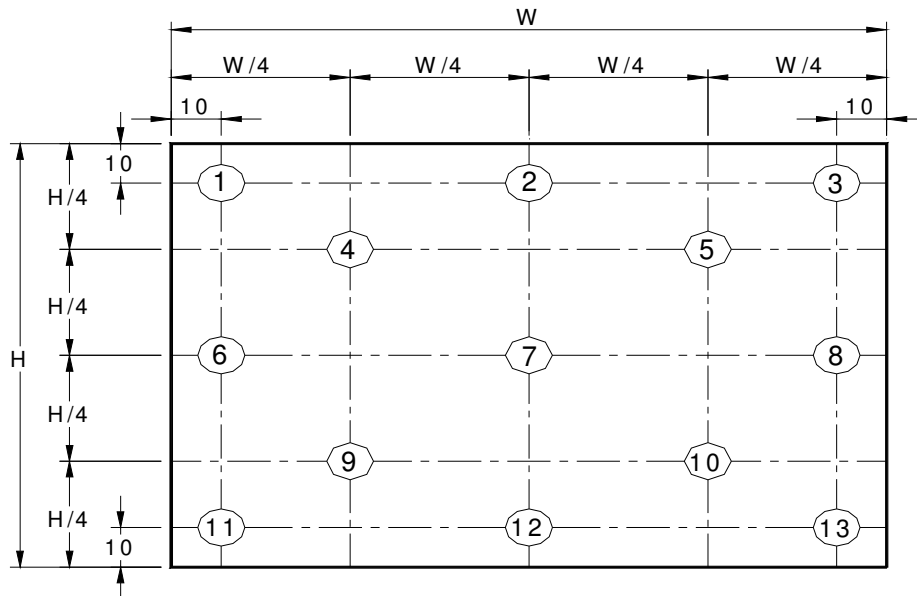

Note 3: The luminance uniformity of 5 or 13 points is defined by dividing the maximum luminance values by the minimum test point luminance

$$\delta_{w5} = \frac{\text{Maximum Brightness of five points}}{\text{Minimum Brightness of five points}}$$

$$\delta_{w13} = \frac{\text{Maximum Brightness of thirteen points}}{\text{Minimum Brightness of thirteen points}}$$

Note 4: Measurement method

The LCD module should be stabilized at given temperature for 30 minutes to avoid abrupt temperature change during measuring. In order to stabilize the luminance, the measurement should be executed after lighting Backlight for 30 minutes in a stable, windless and dark room, and it should be measured in the center of screen.

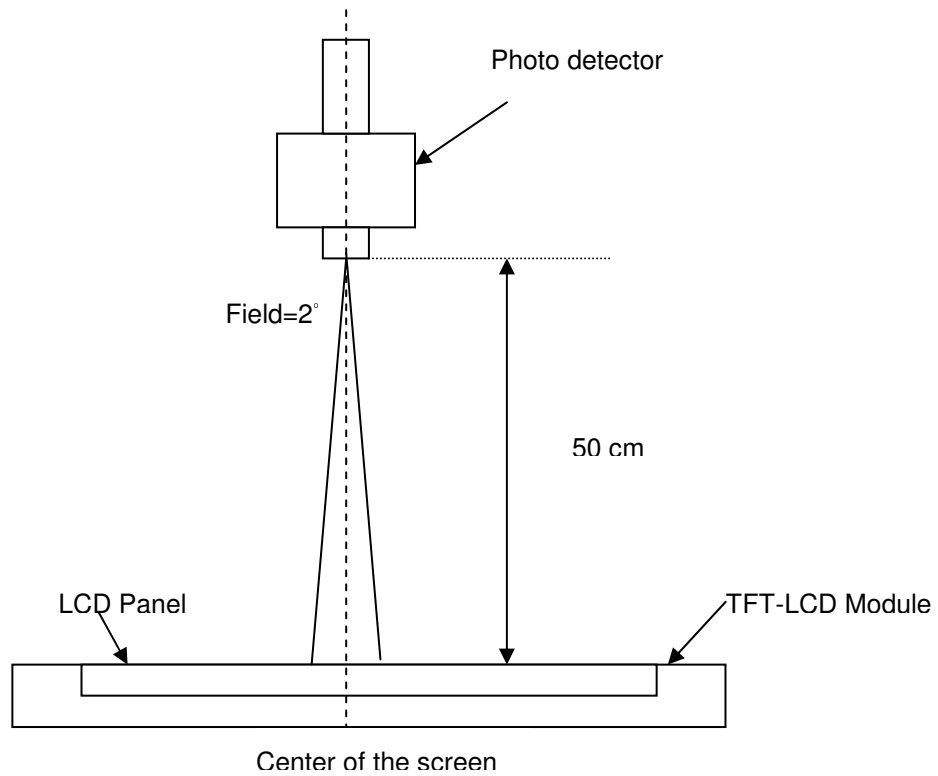

Note 5 : Definition of Average Luminance of White (Y_L):

Measure the luminance of gray level 63 at 5 points · $Y_L = [L (1)+ L (2)+ L (3)+ L (4)+ L (5)] / 5$

$L (x)$ is corresponding to the luminance of the point X at Figure in Note (1).

Note 6 : Definition of contrast ratio:

Contrast ratio is calculated with the following formula.

$$\text{Contrast ratio (CR)} = \frac{\text{Brightness on the "White" state}}{\text{Brightness on the "Black" state}}$$

Note 7 : Definition of Cross Talk (CT)

$$CT = |Y_B - Y_A| / Y_A \times 100 (\%)$$

Where

Y_A = Luminance of measured location without gray level 0 pattern (cd/m²)

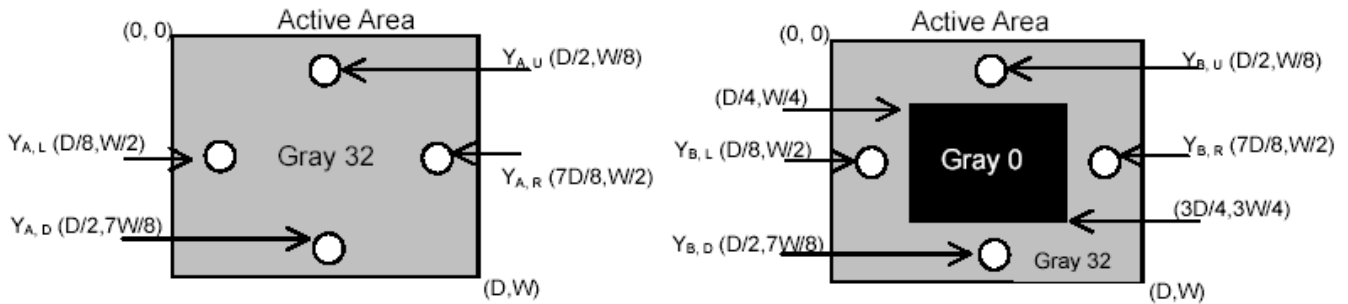

Note 8: Definition of response time:

The output signals of BM-7 or equivalent are measured when the input signals are changed from "Black" to "White" (falling time) and from "White" to "Black" (rising time), respectively. The response time interval between the 10% and 90% of amplitudes. Refer to figure as below.

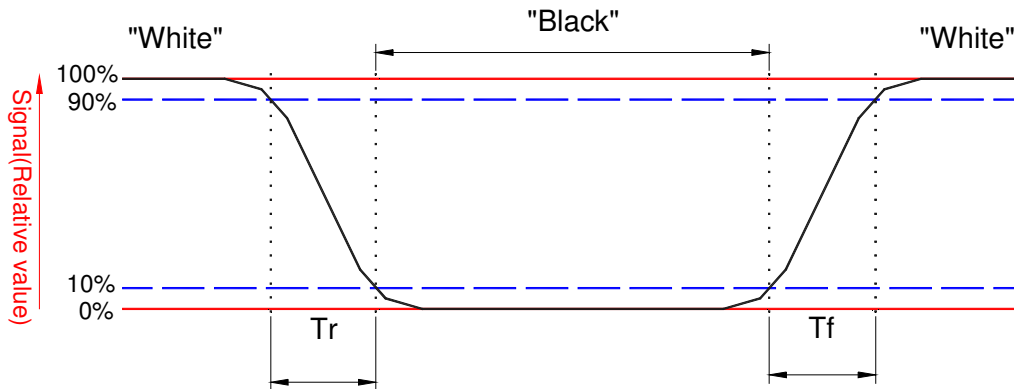

Note 9. Definition of viewing angle

Viewing angle is the measurement of contrast ratio ≥ 10 , at the screen center, over a 180° horizontal and 180° vertical range (off-normal viewing angles). The 180° viewing angle range is broken down as follows; 90° (θ) horizontal left and right and 90° (Φ) vertical, high (up) and low (down). The measurement direction is typically perpendicular to the display surface with the screen rotated about its center to develop the desired measurement viewing angle.

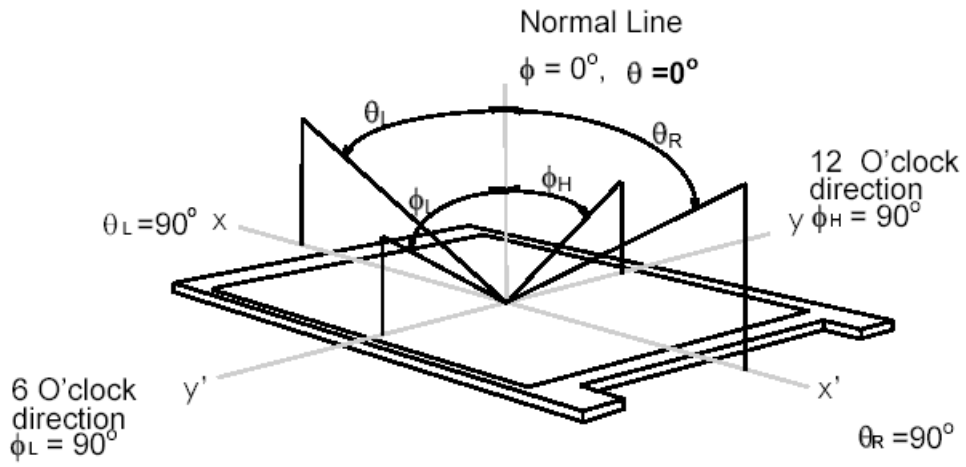

3. Functional Block Diagram

The following diagram shows the functional block of the 7.85 inches wide Color TFT/LCD 32 Pin one channel Module

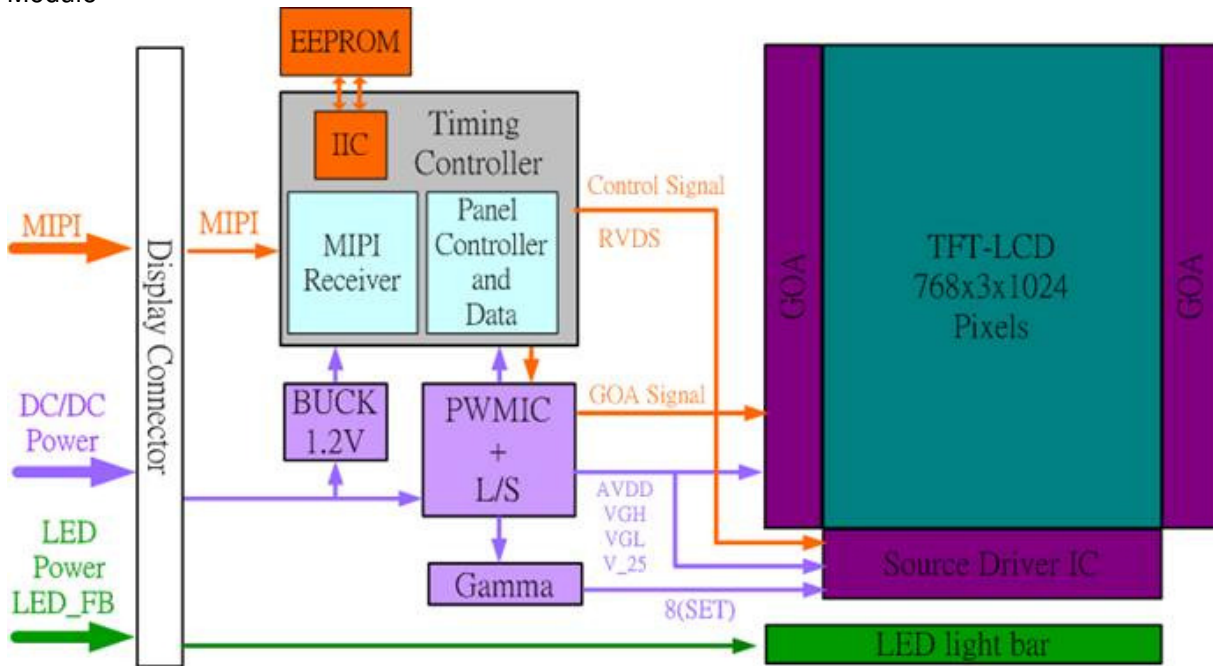

4. Absolute Maximum Ratings

An absolute maximum rating of the module is as following:

4.1 Absolute Ratings of TFT LCD Module

Item	Symbol	Min	Max	Unit	Conditions
Logic/LCD Drive Voltage	Vin	-0.3	+5	[Volt]	Note 1,2

4.2 Absolute Ratings of Environment

Item	Symbol	Min	Max	Unit	Conditions
Operating Temperature	TOP	0	+50	[°C]	Note 4
Operation Humidity	HOP	5	95	[%RH]	Note 4
Storage Temperature	TST	-20	+60	[°C]	Note 4
Storage Humidity	HST	5	95	[%RH]	Note 4

Note 1: At Ta (25°C)

Note 2: Permanent damage to the device may occur if exceed maximum values

Note 3: LED specification refer to section 5.2

Note 4: For quality performance, please refer to AUO IIS (Incoming Inspection Standard).

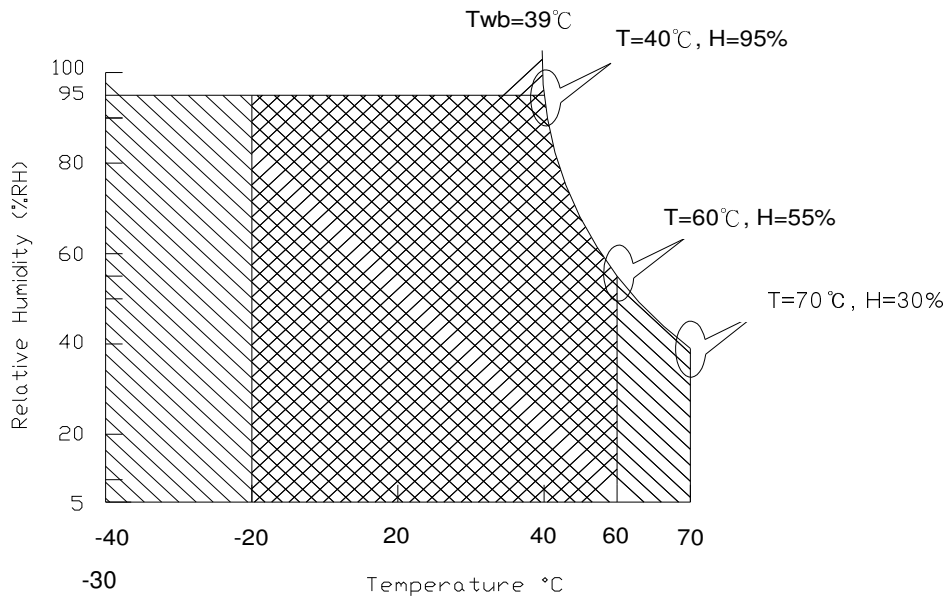

Operating Range 

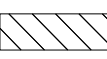
Storage Range  + 

5. Electrical Characteristics

5.1 TFT LCD Module

5.1.1 Power Specification

Input power specifications are as follows;

The power specification are measured under 25°C and frame frequency under 60Hz

Symble	Parameter	Min	Typ	Max	Units	Note
VDD	Logic/LCD Drive Voltage	3.4	3.7	4.3	[Volt]	
PDD	VDD Power	-	-	0.79	[Watt]	Note 1
IDD	IDD Current	-	-	-	[mA]	Note 1
IRush	Inrush Current	-	-	-	[mA]	Note 2
VDDrp	Allowable Logic/LCD Drive Ripple Voltage	-	-	-	[mV] p-p	

Note 1 : Maximum Measurement Condition : White Pattern at 3.3V driving voltage. ($P_{max}=V_{3.3} \times I_{white}$)

Note 2 : Measure Condition

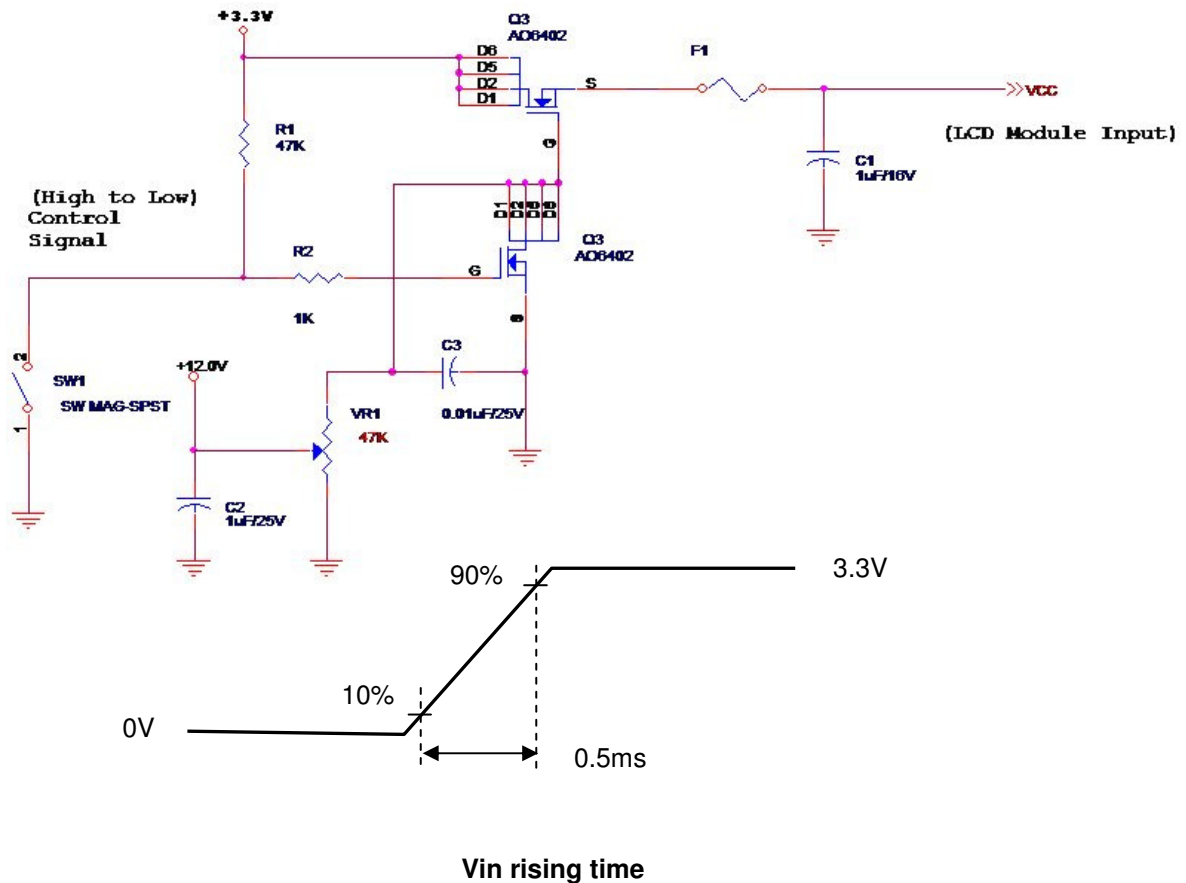

5.1.2 Signal Electrical Characteristics

Input signals shall be low or High-impedance state when VDD is off.

MIPI DC/AC Characteristics are as follows;

MIPI Receiver Differential Input (DC Characteristics)					
Symbol	Parameter	Min	Typ	Max	Unit
BR _{MIPI}	Input data bit rate	-	513	560	Mbps
V _{IDTH}	Differential input high threshold (HS Rx mode)	-	-	70	mV
V _{IDTL}	Differential input low threshold (HS Rx mode)	-70	-	-	mV
V _{IHHS}	Single-end input high voltage (HS Rx mode)	-	-	460	mV
V _{ILHS}	Single-end input low voltage (HS Rx mode)	-40	-	-	mV
Z _{ID}	Differential input impedance	80	100	125	Ω
V _{IHLP}	Logic 1 input voltage (LP Rx mode)	880	-	-	mV
V _{ILLP}	Logic 0 input voltage (LP Rx mode)	-	-	550	mV
V _{HYST}	Input hysteresis	25	-	-	V
V _{IHCD}	Logic 1 contention threshold	450	-	-	mV
V _{ILCD}	Logic 0 contention threshold	-	-	200	mV

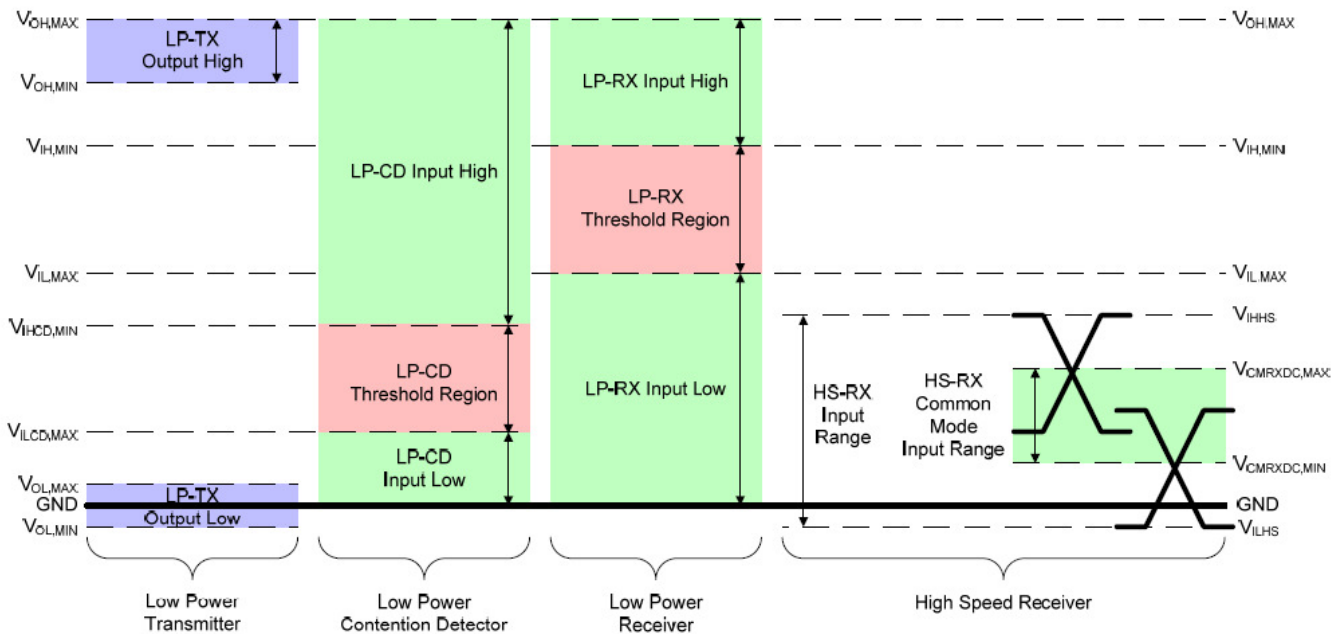

MIPI Receiver Input AC Electrical Characteristics						
Symbol	Parameter	Conditions	Min	Typ	Max	Unit
$\Delta V_{CMRX(HF)}$	Common-mode interference beyond 450MHz		-	-	100	mV
$\Delta V_{CMRX(LF)}$	Common-mode interference 50MHz ~ 450MHz		-50	-	50	mV
C_{CM}	Common-mode termination		-	-	60	pF

HS RX Scheme

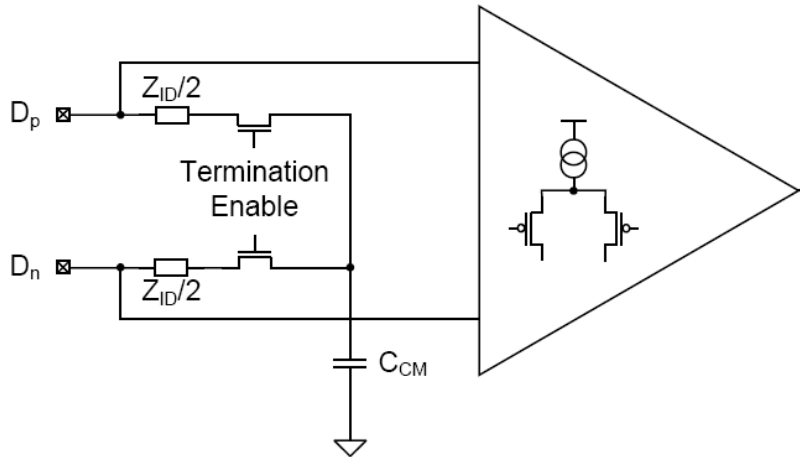

LP Receiver AC Specifications						
Symbol	Parameter	Conditions	Min	Typ	Max	Unit
e_{SPIKE}	Input pulse rejection		-	-	300	$V \cdot ps$
T_{MIN-RX}	Minimum pulse width response		50	-	-	ns
V_{INT}	Peak interference amplitude		-	-	200	mV
f_{INT}	Interference frequency		450	-	-	MHz

Input Glitch Rejection of Low-Power Receivers

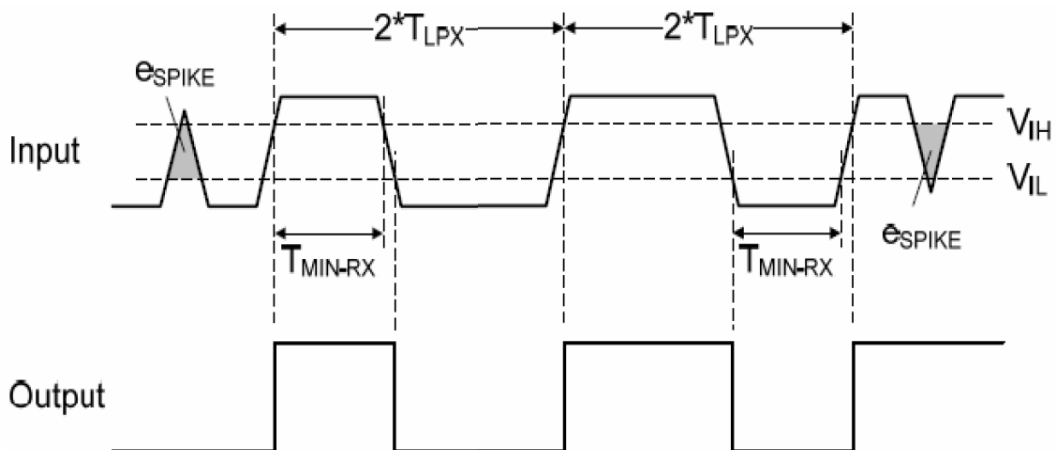



5.2 Backlight Unit

5.2.1 LED characteristics

Parameter	Symbol	Min	Typ	Max	Units	Condition
Backlight Power Consumption	PLED	-	-	1.518	[Watt]	(Ta=25°C @21.8mA)
LED Life-Time	N/A	10,000	-	-	Hour	(Ta=25°C @21.8mA) Note1.

Note 1. The LED life-time define as the estimated time to 50% degradation of initial luminous.

Note 2. Every LED string consists of 10 pcs LED chip

6. Signal Interface Characteristic

6.1 Pixel Format Image

Following figure shows the relationship of the input signals and LCD pixel format.

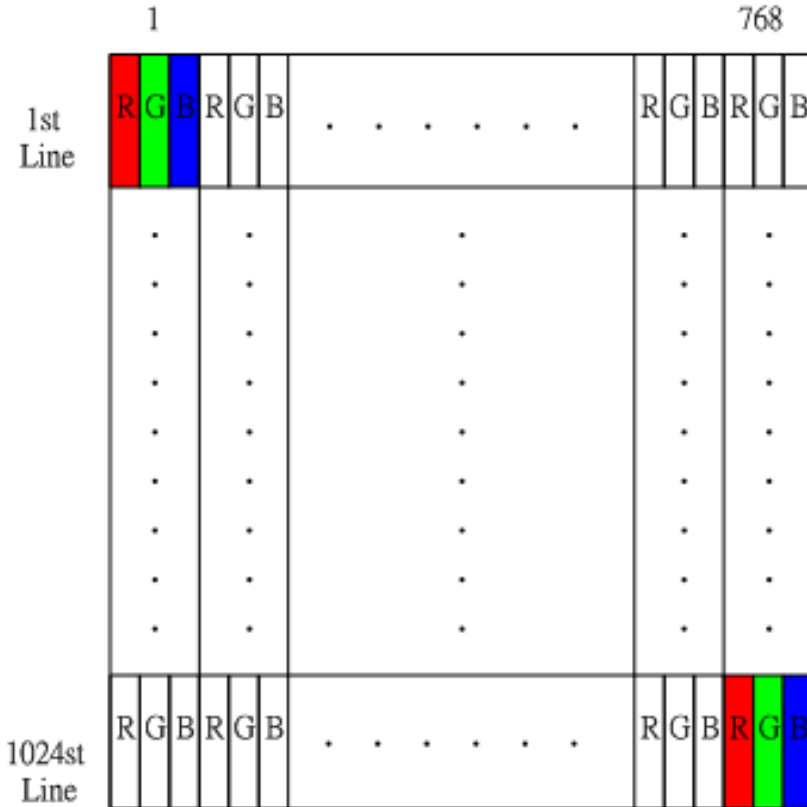

6.2 Integration Interface Requirement

6.2.1 MIPI Connector Description

Physical interface is described as for the connector on module.

These connectors are capable of accommodating the following signals and will be following components.

Connector Name / Designation	For Signal Connector
Manufacturer	JAPAN AVIATION ELECTRONICS
Type / Part Number	AA07-P032VA1
Mating Housing/Part Number	B2B

6.2.2 MIPI Pin Assignment

MIPI is a differential signal technology for LCD interface and high speed data transfer device.

No.	Pin Name	Description
1	GND	Ground
2	VCC	Power Supply
3	MIPI_DATA3_N	MIPI data pair 3 negative signal
4	VCC	Power Supply
5	MIPI_DATA3_P	MIPI data pair 3 positive signal
6	VCC	Power Supply
7	GND	Ground
8	VCC	Power Supply
9	MIPI_DATA2_N	MIPI data pair 2 negative signal
10	VCC	Power Supply
11	MIPI_DATA2_P	MIPI data pair 2 positive signal
12	GND	Ground
13	GND	Ground
14	RST	RESET
15	MIPI_DATA1_N	MIPI data pair 1 negative signal
16	GND	Ground
17	MIPI_DATA1_P	MIPI data pair 1 positive signal
18	LED_FB3	BL Feedback pin
19	GND	Ground
20	LED_FB2	BL Feedback pin
21	MIPI_DATA0_N	MIPI data pair 0 negative signal
22	LED_FB1	BL Feedback pin
23	MIPI_DATA0_P	MIPI data pair 0 positive signal
24	LED_FB0	BL Feedback pin
25	GND	Ground
26	LED_FB4	BL Feedback pin
27	MIPI_CLK_N	MIPI Clock negative signal
28	LED_FB5	BL Feedback pin
29	MIPI_CLK_P	MIPI Clock positive signal
30	LED PW	LED Anode
31	GND	Ground
32	LED PW	LED Anode

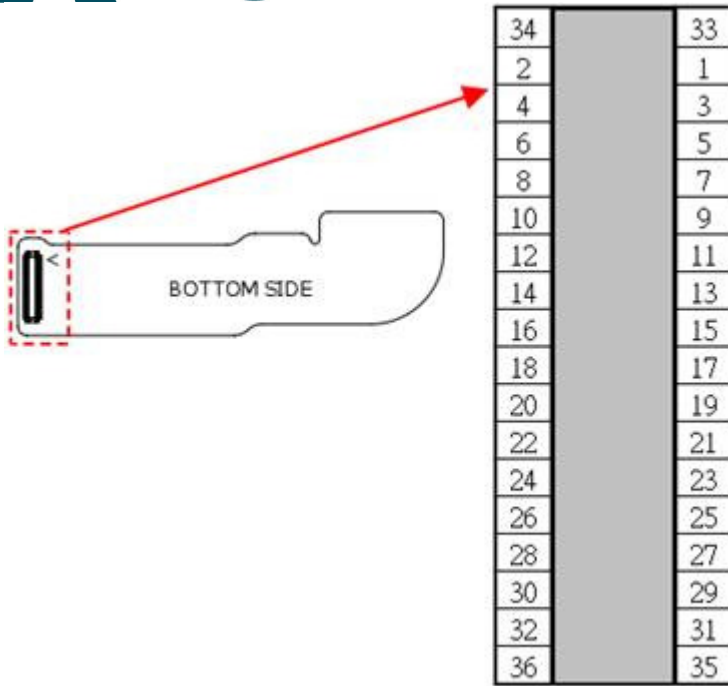

Note1: Input signals shall be low or High-impedance state when VDD is

6.3 MIPI Interface Timing

6.4.1 Timing Characteristics

Basically, interface timings should match the 768x1024 /60Hz manufacturing guide line timing.

Parameter		Symbol	Min.	Typ.	Max.	Unit
Frame Rate		---	---	60	---	Hz
Clock frequency		1/ T _{Clock}	---	64	---	MHz
Vertical Section	Period	T _V	---	1140	---	T _{Line}
	Active	T _{VD}	1024			
	Blanking	T _{VB}	---	116	---	
Horizontal Section	Period	T _H	---	948	---	T _{Clock}
	Active	T _{HD}	768			
	Blanking	T _{HB}	---	180	---	

6.4 Power ON/OFF Sequence

Power on/off sequence is as follows. Interface signals and LED on/off sequence are also shown in the chart.

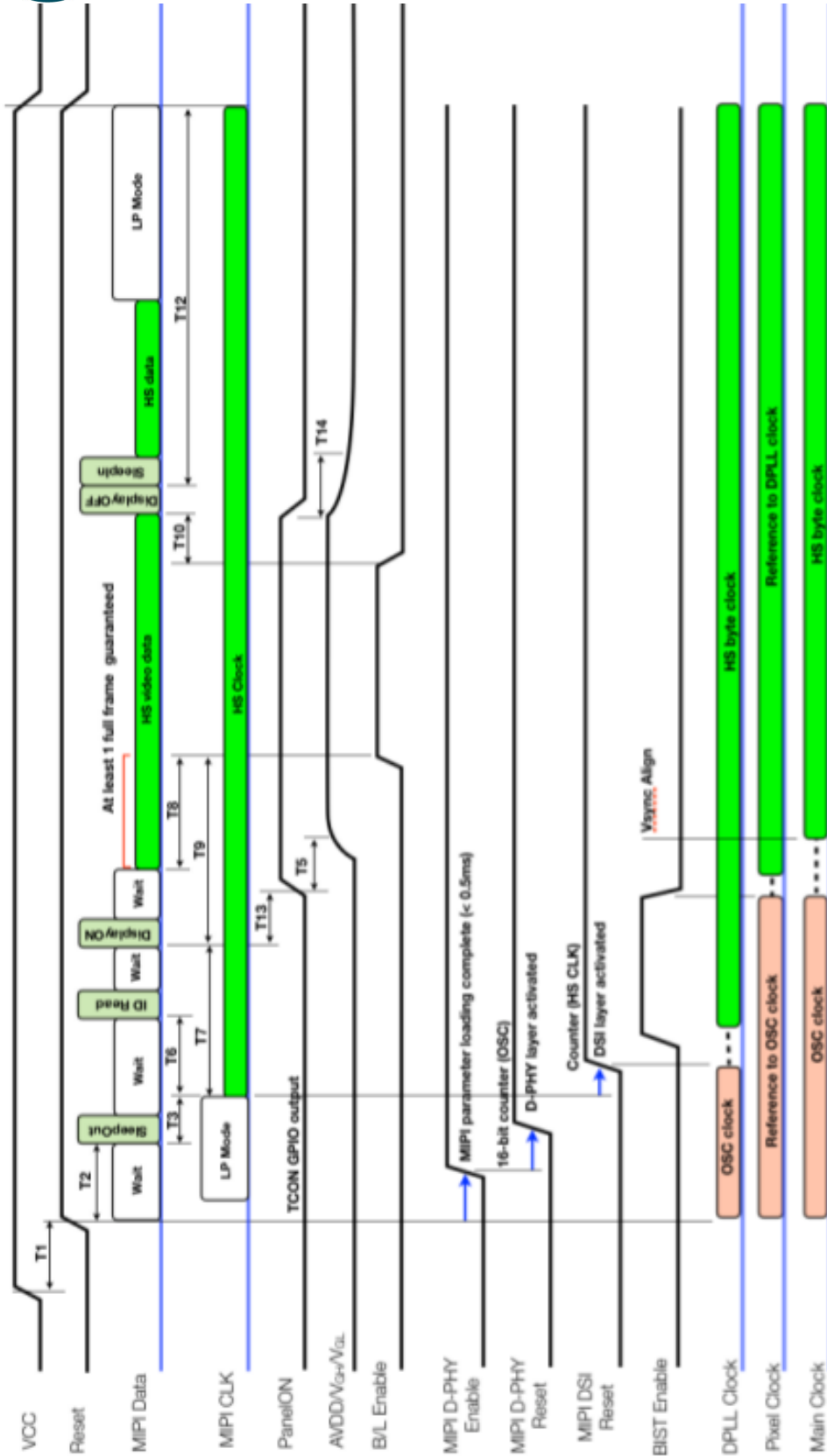



Product Specification

AU OPTRONICS CORPORATION

Unit : [ms] unless specified otherwise

Parameter	Symbol	Min	Typ	Max	Remarks
Reset de-assertion delay	T1	5	10	-	
Reset to first LP command (SLEEP_OUT)	T2	5	6	10	
SLEEP_OUT to HS clock enable	T3	4(us)	-	-	
AVdd Turn-ON delay	T5	-	-	3.5	From PanelON assertion
HS clock enable to vendor ID reading	T6	25	-	-	Prior to this, vendor ID should be ready at internal register.
HS clock enable to DISPLAY_ON	T7	100	-	-	
Valid video data to B/L ON	T8	16.67	33.33	-	At least one full frame guaranteed
DISPLAY_ON to B/L ON	T9	83.35	-	-	Black and normal frames mixed
B/L OFF to DISPLAY_OFF	T10	16.67	-	-	At least one full frame guaranteed
SLEEP_IN to HS clock disable & Reset	T12	100	-	-	
DISPLAY_ON to PanelON	T13	-	-	5	TCON internal programmable delay
AVdd power discharge time	T14	-	-	5	Decided by decoupling capacitance

Note1. T4 and T11 are irrelevant to TCON timing, so omitted.

Note2. TCON should finish its parameter loading and vendor ID loading within T2+T3+T6



Product Specification

AU OPTRONICS CORPORATION

7.2 Standard Rear View

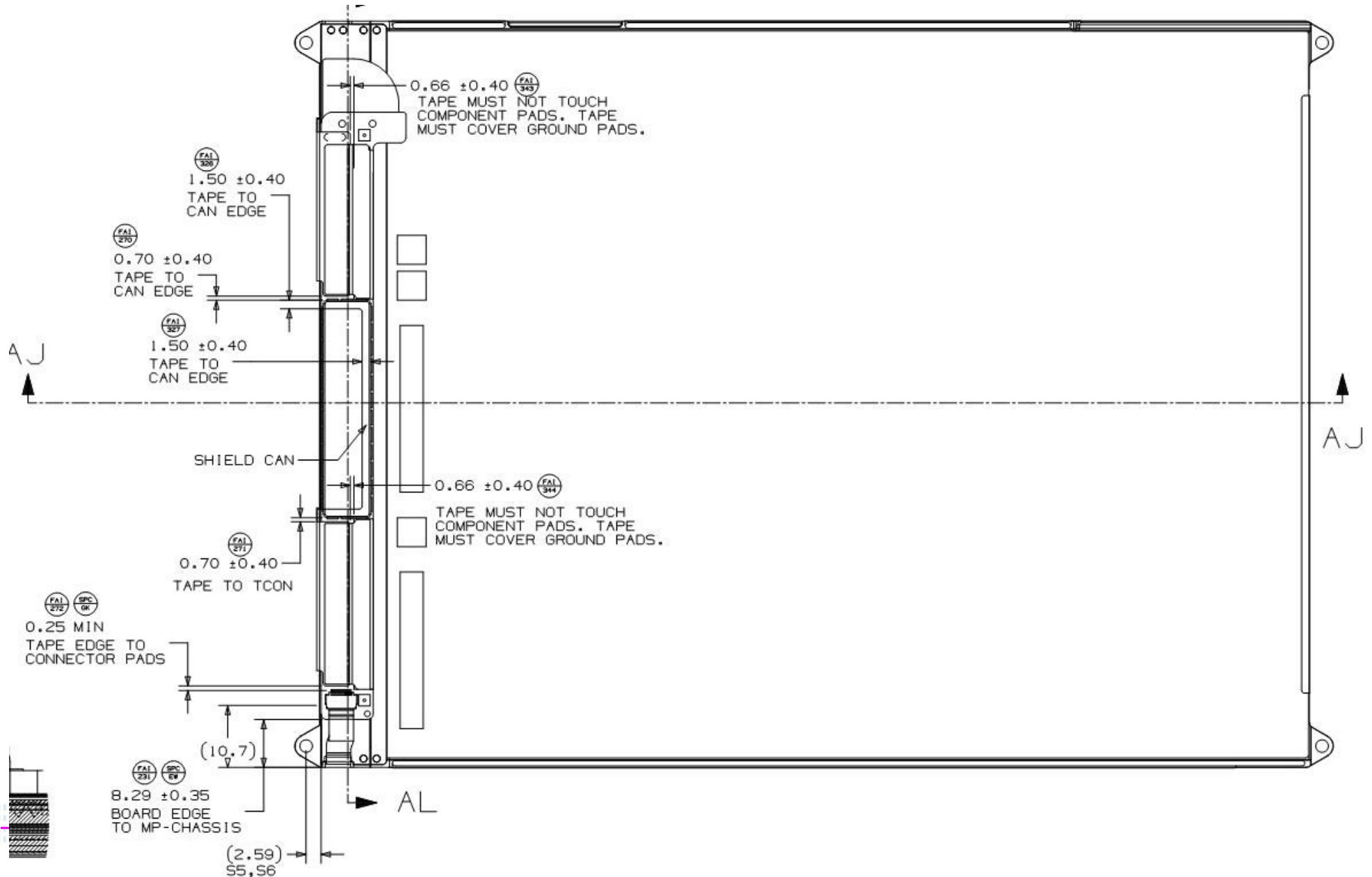

B080XAN01.0

8. Shipping and Package

8.1 Carton Package

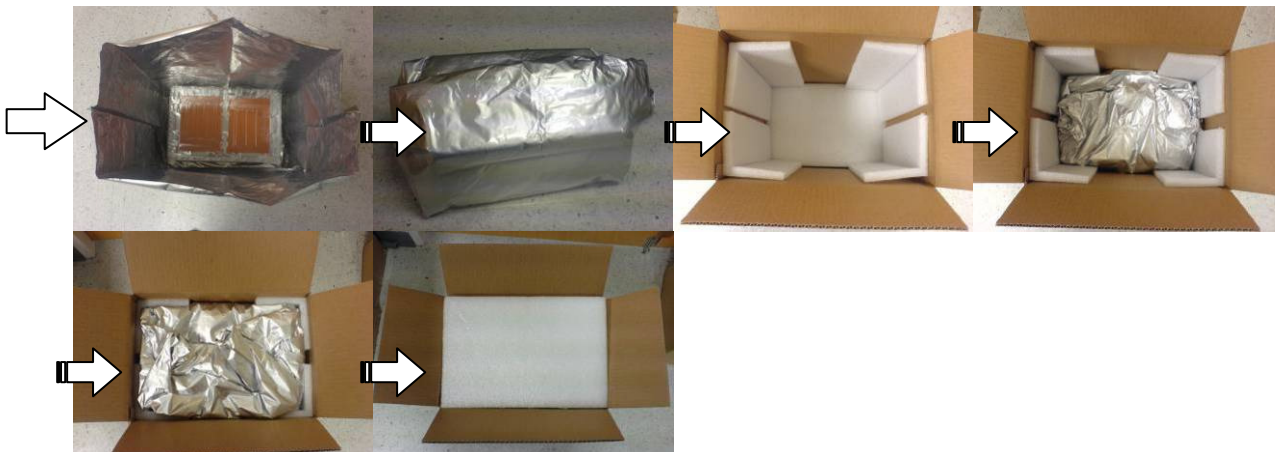
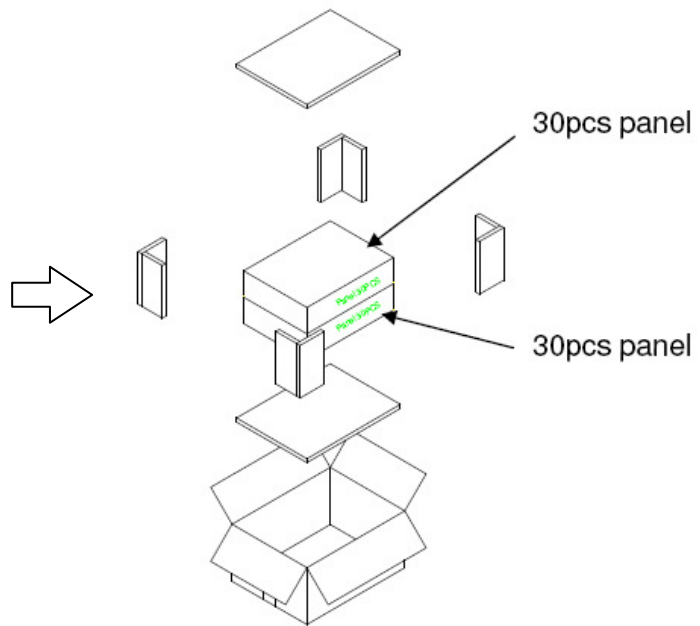
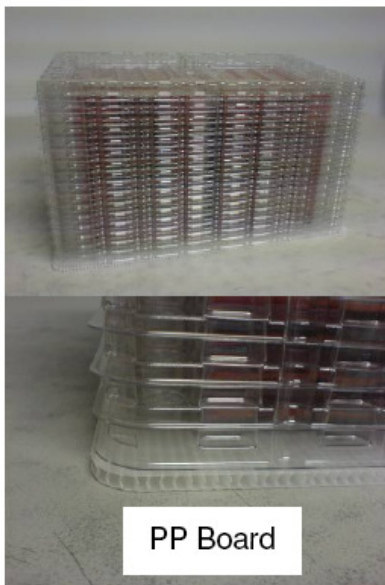
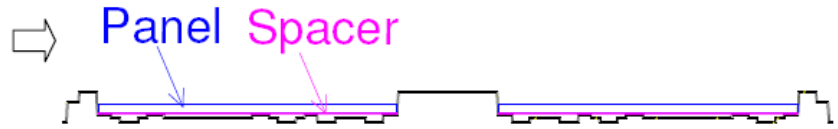
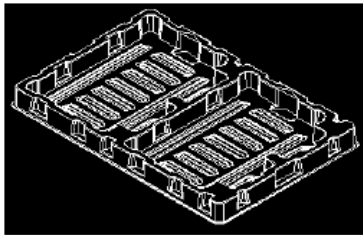

- Pallet : 1150mm* 840mm*132mm
- Stretch film : 500mm (W)*300M (L)
- Corner angle : L type fiber board
- PET band : 19mm (W)
- Label : 220mm*200mm

8.2 Shipping Package of Palletizing Sequence

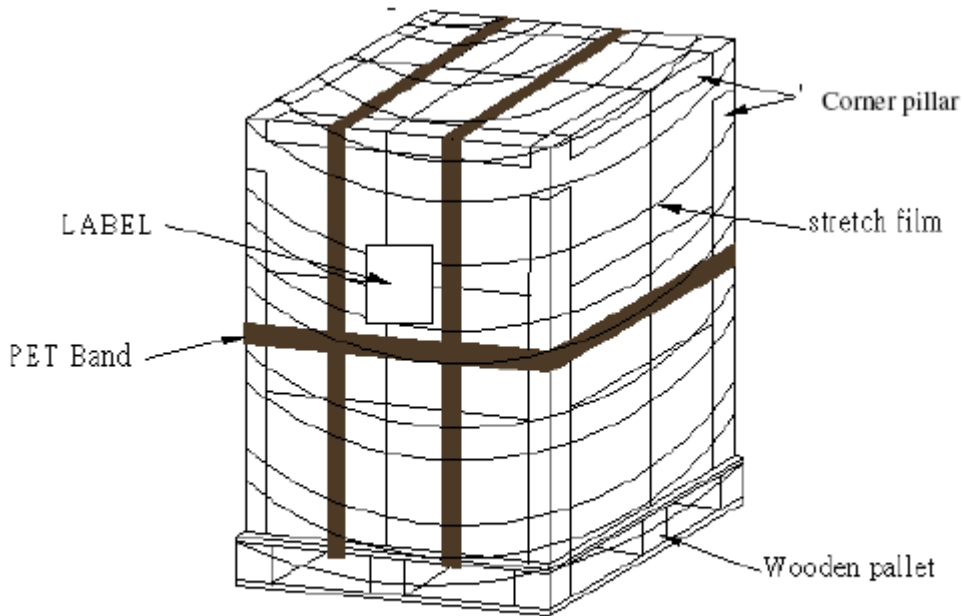

單層 pallet 打棧示意圖