



LTC1706-63

5-Bit VID Voltage Programmer for Sun CPUs

FEATURES

- Programs Regulator Output Voltage Range from 1.025V to 1.4125V in 12.5mV Steps
- Programs a Wide Range of Linear Technology DC/DC Converters with a 0.6V Reference
- $\pm 0.35\%$ Accurate Output Voltage
- Built-In 40k Pull-Up Resistors on VID Inputs
- Available in MSOP-10 Package

APPLICATIONS

- Sun™ Processor Power Supply
- Workstations and Servers
- Large Memory Array Supply

DESCRIPTION

The LTC[®]1706-63 is a precision, digitally programmed, resistive ladder which adjusts the output of any 0.6V referenced regulator. Depending on the state of the five VID inputs, an output voltage between 1.025V and 1.4125V is programmed in 12.5mV increments.

The LTC1706-63 is designed specifically to program an entire family of Linear Technology DC/DC converters with on board 0.6V references. Please see the related parts list at the end of the data sheet.

For a 2-phase synchronous controller with on-board LTC1706-63, see the LTC3819.

LT, LTC and LT are registered trademarks of Linear Technology Corporation. All other trademarks are the property of their respective owners.

TYPICAL APPLICATION

5-Bit VID-Controlled High Current Application (Simplified Block Diagram)

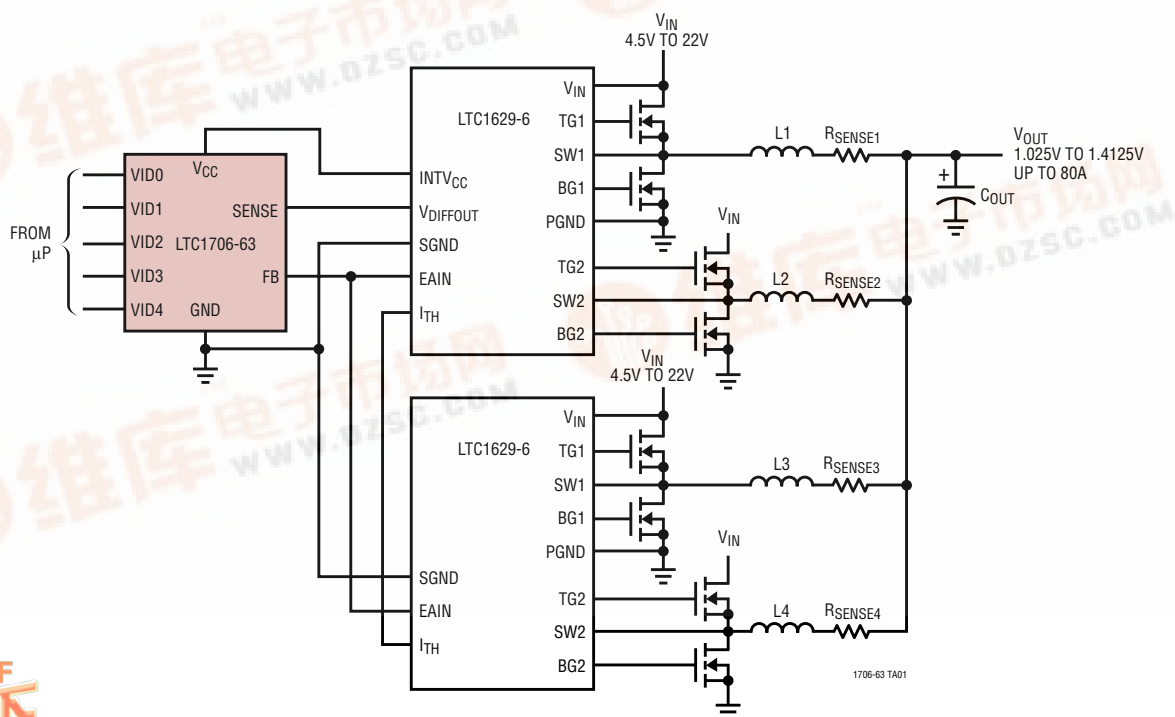

1706-63 TA01



ABSOLUTE MAXIMUM RATINGS

(Note 1)

(Voltages Referred to GND Pin)

Input Supply Voltage (V_{CC})	-0.3V to 7V
VID Input Pins	-0.3V to 7V
SENSE Pin	-0.3V to 7V
FB Pin	-0.3V to 7V
Operating Ambient Temperature Range (Note 2)	-40°C to 85°C
Junction Temperature	110°C
Storage Temperature Range	-65°C to 150°C
Lead Temperature (Soldering, 10 sec)	300°C

PACKAGE/ORDER INFORMATION

TOP VIEW

MS PACKAGE
10-LEAD PLASTIC MSOP
 $T_{JMAX} = 110^{\circ}\text{C}$, $\theta_{JA} = 120^{\circ}\text{C}/\text{W}$

ORDER PART NUMBER	MS PART MARKING
LTC1706EMS-63	LTBXM

Order Options Tape and Reel: Add #TR
 Lead Free: Add #PBF Lead Free Tape and Reel: Add #TRPBF
 Lead Free Part Marking: <http://www.linear.com/leadfree/>

Consult LTC Marketing for parts specified with wider operating temperature ranges.

ELECTRICAL CHARACTERISTICS

The ● denotes specifications which apply over the full operating temperature range, otherwise specifications are $T_A = 25^{\circ}\text{C}$.
 $2.7\text{V} \leq V_{CC} \leq 5.5\text{V}$, $\text{VID0} = \text{VID1} = \text{VID2} = \text{VID3} = \text{VID4} = \text{NC}$ unless otherwise specified.

SYMBOL	PARAMETER	CONDITIONS	MIN	TYP	MAX	UNITS
V_{CC}	Operating Supply Voltage Range		2.7		5.5	V
I_{VCC}	Supply Current	(Note 3)		0.1	5	μA
$R_{\text{FB-SENSE}}$	Resistance Between SENSE and FB		● 3	5	7	$\text{k}\Omega$
$V_{\text{OUT Error \%}}$	Output Voltage Accuracy		● -0.35		+0.35	%
R_{PULLUP}	VID Input Pull-Up Resistance	$V_{\text{DIODE}} = 0.6\text{V}$ (Note 4)		40		$\text{k}\Omega$
VID_{TH}	VID Input Voltage Threshold	$V_{\text{IL}} (2.7\text{V} \leq V_{CC} \leq 5.5\text{V})$ $V_{\text{IH}} (2.7\text{V} \leq V_{CC} \leq 5.5\text{V})$			0.4	V
$I_{\text{VID-LEAK}}$	VID Input Leakage Current	$V_{CC} < \text{VID} < 7\text{V}$ (Note 4)		0.01	± 1	μA
V_{PULLUP}	VID Pull-Up Voltage	$V_{CC} = 3.3\text{V}$ $V_{CC} = 5\text{V}$		2.8		V
				4.5		V

Note 1: Absolute Maximum Ratings are those values beyond which the life of a device may be impaired.

Note 2: The LTC1706EMS-63 is guaranteed to meet performance specifications from 0°C to 70°C. Specifications over the -40°C to 85°C operating temperature range are assured by design, characterization and correlation with statistical process controls.

Note 3: With all five VID inputs floating, the V_{CC} supply current is simply the device leakage current. However, the V_{CC} supply current will rise and be approximately equal to the number of grounded VID input pins times $(V_{CC} - 0.6\text{V})/40\text{k}$. (See the VID Input Characteristics section for more details.)

Note 4: Each built-in pull-up resistor attached to the VID inputs also has a series diode connected to V_{CC} to allow input voltages higher than the V_{CC} supply without damage or clamping. (See Operation section for further details.)

TYPICAL PERFORMANCE CHARACTERISTICS

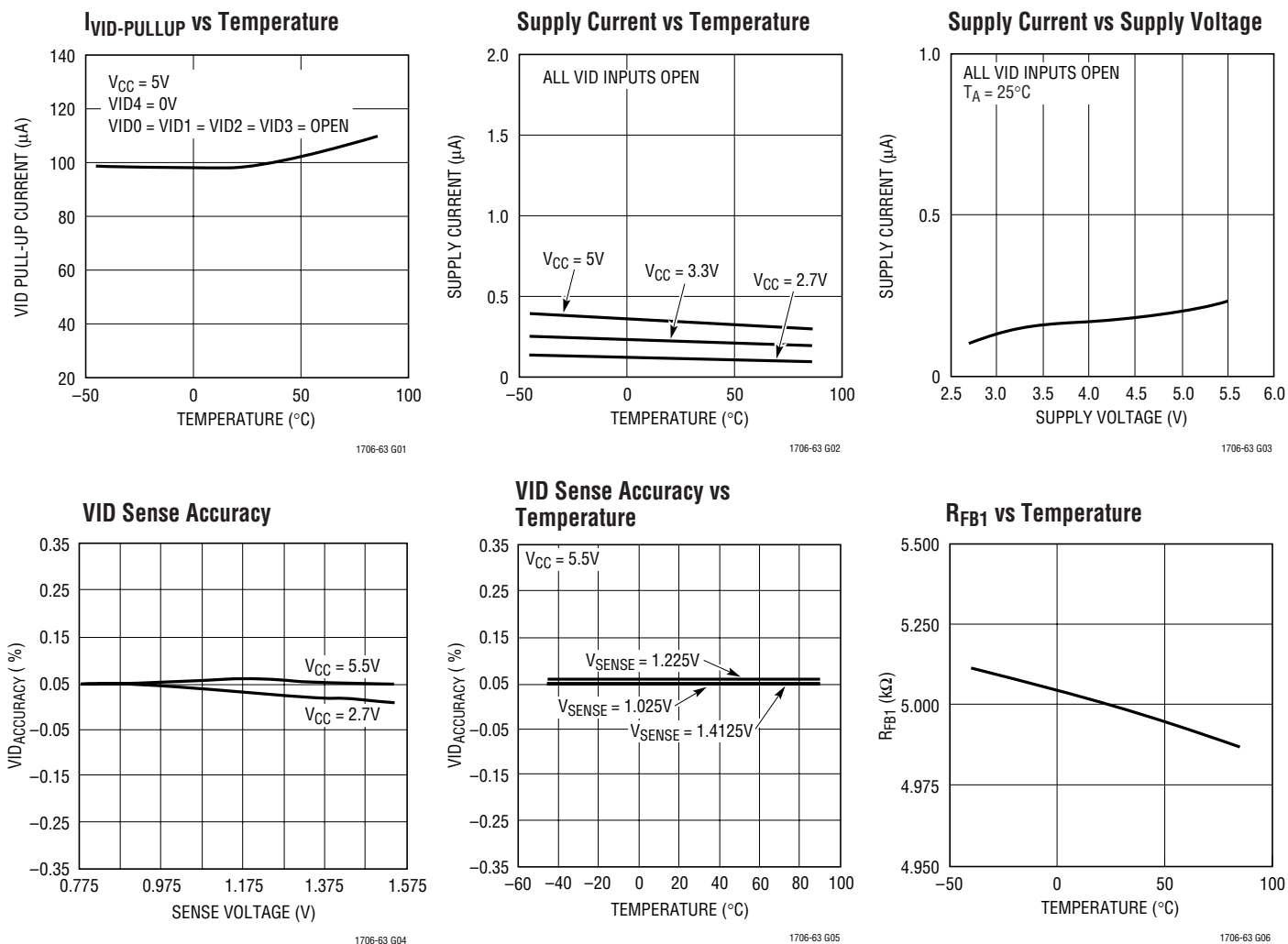

PIN FUNCTIONS

VID0 (Pin 1): LSB Programming Input. Low = GND, High = V_{CC} or Float. Grounding VID0 adds 12.5mV to the output sense voltage.

VID1 (Pin 2): 4th MSB Programming Input. Low = GND, High = V_{CC} or Float. Grounding VID1 adds 25mV to the output sense voltage.

VID2 (Pin 3): 3rd MSB Programming Input. Low = GND, High = V_{CC} or Float. Grounding VID2 adds 50mV to the output sense voltage.

VID3 (Pin 4): 2nd MSB Programming Input. Low = GND, High = V_{CC} or Float. Grounding VID3 adds 100mV to the output sense voltage.

V_{CC} (Pin 5): Power Supply Voltage. Range from 2.7V to 5.5V.

SENSE (Pin 6): Regulator Output Voltage. Connect directly to regulator output sense node.

VID4 (Pin 7): MSB Programming Input. Low = GND, High = V_{CC} or Float. Grounding VID4 adds 200mV to the output sense voltage.

NC (Pin 8): No Connect.

GND (Pin 9): Ground. Connect to regulator signal ground.

FB (Pin 10): Feedback Input. Connect to the 0.6V feedback pin of a compatible regulator.

PIN FUNCTIONS

PIN	NAME	DESCRIPTION	NOMINAL (V)			ABSOLUTE MAX (V)	
			MIN	TYP	MAX	MIN	MAX
1	VID0	LSB Programmable Input	0		V_{CC}	-0.3	7
2	VID1	4th MSB Programmable Input	0		V_{CC}	-0.3	7
3	VID2	3rd MSB Programmable Input	0		V_{CC}	-0.3	7
4	VID3	2nd MSB Programmable Input	0		V_{CC}	-0.3	7
5	V_{CC}	Power Supply	2.7		5.5	-0.3	7
6	SENSE	Regulator Output Voltage	0.8		1.55	-0.3	7
7	VID4	1st MSB Programmable Input	0		V_{CC}	-0.3	7
8	NC						
9	GND	Ground		0		-0.3	7
10	FB	0.6V Feedback Input	0	0.6	1.5	-0.3	7

BLOCK DIAGRAM

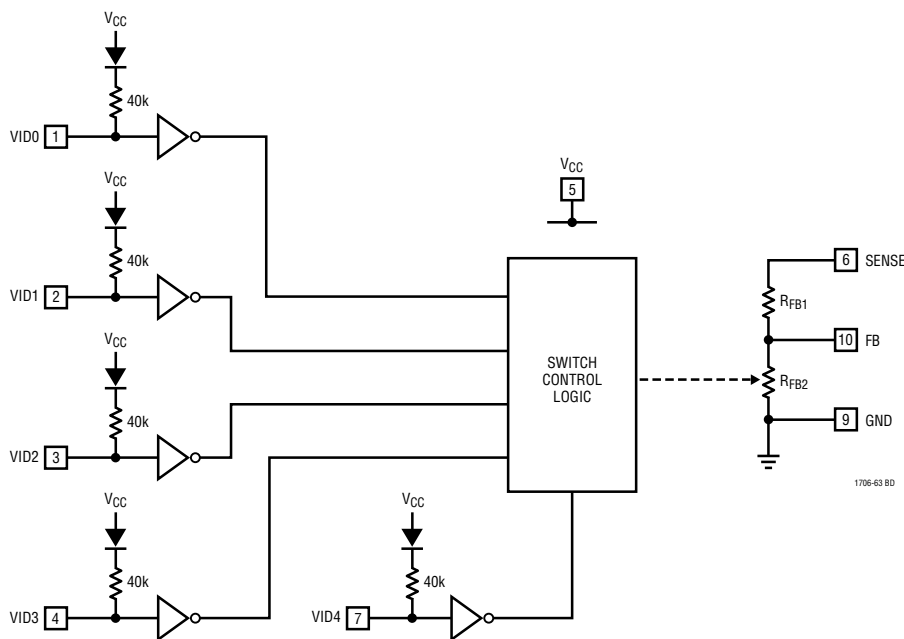

OPERATION

The LTC1706-63 is a precision resistive divider designed specifically for use with an entire family of Linear Technology Corporation DC/DC switching regulators with 0.6V internal reference and feedback voltage. The LTC1706-63 produces an output voltage ranging from 1.025V to 1.4125V in 12.5mV steps by closing the loop between the output voltage sense and the feedback input of the regulator with the appropriate resistive divider network.

The “top” feedback resistor, R_{FB1} , connected between SENSE and FB, is typically 5k and is not modified by the state of the VID program inputs.

The “bottom” feedback resistor, R_{FB2} , however, is modified by the five VID inputs and is precisely ratioed to R_{FB1} .

OPERATION

VID Programming

A list of programmed inputs and their corresponding output voltages is shown in Table 1. Programming is accomplished by applying the proper voltage (or float condition) on the five digital VID inputs.

Table 1. VID Inputs and Corresponding Output Voltage

CODE	VID4	VID3	VID2	VID1	VID0	OUTPUT
00000	GND	GND	GND	GND	GND	1.4125V
00001	GND	GND	GND	GND	Float	1.4000V
00010	GND	GND	GND	Float	GND	1.3875V
00011	GND	GND	GND	Float	Float	1.3750V
00100	GND	GND	Float	GND	GND	1.3625V
00101	GND	GND	Float	GND	Float	1.3500V
00110	GND	GND	Float	Float	GND	1.3375V
00111	GND	GND	Float	Float	Float	1.3250V
01000	GND	Float	GND	GND	GND	1.3125V
01001	GND	Float	GND	GND	Float	1.3000V
01010	GND	Float	GND	Float	GND	1.2875V
01011	GND	Float	GND	Float	Float	1.2750V
01100	GND	Float	Float	GND	GND	1.2625V
01101	GND	Float	Float	GND	Float	1.2500V
01110	GND	Float	Float	Float	GND	1.2375V
01111	GND	Float	Float	Float	Float	1.2250V
10000	Float	GND	GND	GND	GND	1.2125V
10001	Float	GND	GND	GND	Float	1.2000V
10010	Float	GND	GND	Float	GND	1.1875V
10011	Float	GND	GND	Float	Float	1.1750V
10100	Float	GND	Float	GND	GND	1.1625V
10101	Float	GND	Float	GND	Float	1.1500V
10110	Float	GND	Float	Float	GND	1.1375V
10111	Float	GND	Float	Float	Float	1.1250V
11000	Float	Float	GND	GND	GND	1.1125V
11001	Float	Float	GND	GND	Float	1.1000V
11010	Float	Float	GND	Float	GND	1.0875V
11011	Float	Float	GND	Float	Float	1.0750V
11100	Float	Float	Float	GND	GND	1.0625V
11101	Float	Float	Float	GND	Float	1.0500V
11110	Float	Float	Float	Float	GND	1.0375V
11111	Float	Float	Float	Float	Float	1.0250V

When all five VID inputs are high or floating, such as when no CPU is present in a system, a regulated 1.025V output is generated at V_{SENSE} .

Each VID input pin is pulled up by a 40k resistor in series with a diode connected to V_{CC} . Therefore, it should be grounded (or driven low) to produce a digital low input. It can either be floated or connected to V_{CC} to get a digital high input. The series diode is included to prevent the input from being damaged or clamped when it is driven higher than V_{CC} .

Voltage Sensing and Feedback Pins

The FB pin is a high impedance node that requires minimum layout distance to reduce extra loading and unwanted stray pickup.

When used with the LTC1629-6, the LTC1706-63's FB, SENSE, V_{CC} and GND pins should be connected, respectively, with the EAIN, $V_{DIFFOUT}$, $INTV_{CC}$ and SGND pins of the LTC1629-6. The result of this application is a precisely controlled, variable output voltage supply to any low voltage, high current system such as a powerful personal computer, workstation or network server.

VID Input Characteristics

The VID inputs should be driven with a maximum V_{IL} of 0.4V and a minimum V_{IH} of 1.6V. However, the VID input range is not limited to values less than V_{CC} . Because of the internal diode between V_{CC} and the pull-up resistor, the inputs can go higher than V_{CC} without being clamped to V_{CC} or damaging the input.

This allows the LTC1706-63 to be fully logic compatible and operational over a higher input voltage range (less than the 7V absolute maximum rating).

When a VID input is grounded, there will be a higher quiescent current flow from V_{CC} because of a resistor from V_{CC} through a series diode to each one of the inputs. This increase in quiescent current is calculated from:

$$I_Q = N(V_{CC} - V_{DIODE})/R_{PULLUP}$$

N is the number of grounded VID inputs. V_{DIODE} is typically 0.6V while R_{PULLUP} has a typical pull-up resistance of 40k Ω .

LTC1706-63

OPERATION

In other words, each VID input has a typical pull-up current of 68 μ A for a 3.3V system.

Besides the LTC1629-6, the LTC1706-63 also programs a whole family of LTC DC/DC converters that have an on-board 0.6V reference. The LTC3714, LTC3778 and

LTC3731 are just a few of the high efficiency step-down switching regulators that will work equally well with the LTC1706-63. The LTC3819 is a VID controlled 2-phase synchronous step-down controller with on-board LTC1706-63.

TYPICAL APPLICATION

2-Phase 12V Input, 1.025V to 1.4125V/45A Max Power Supply (LTC3819) with Adjustable Overvoltage Protection (LTC1706-63)

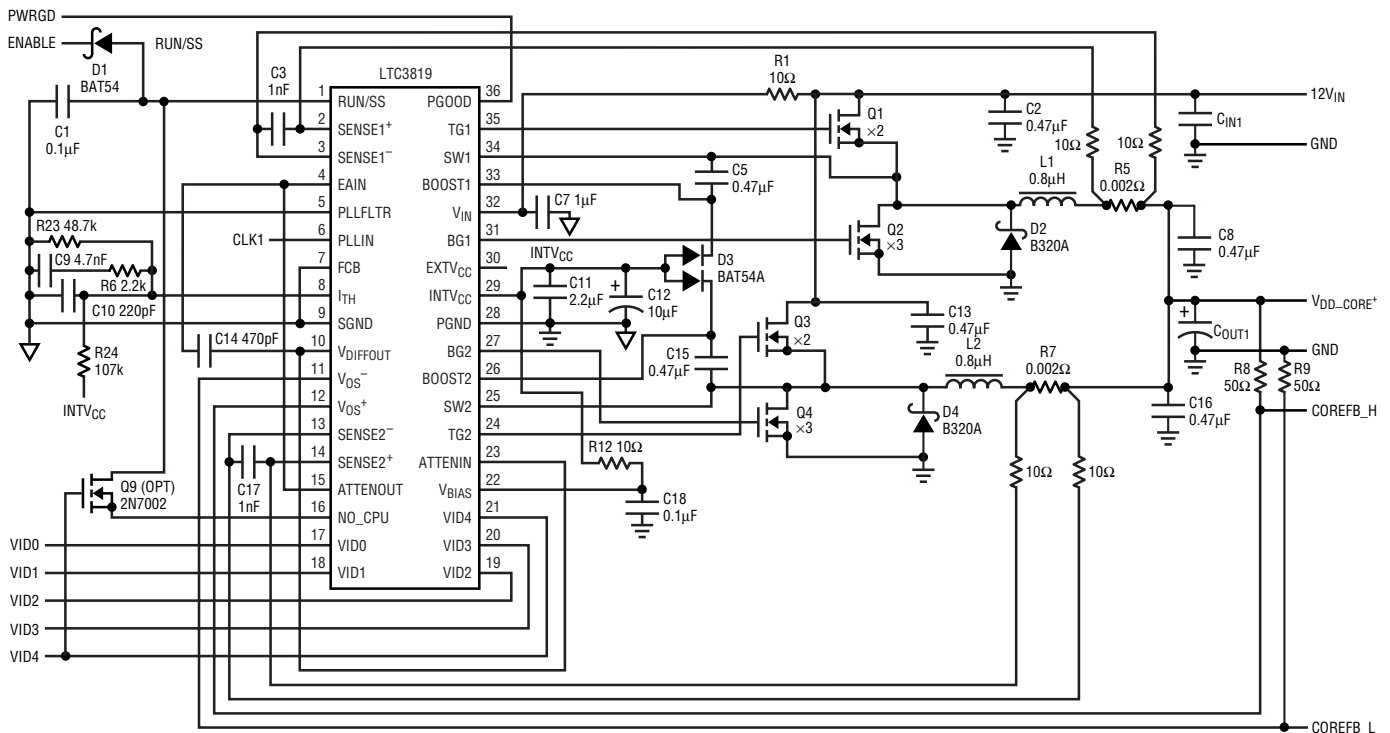
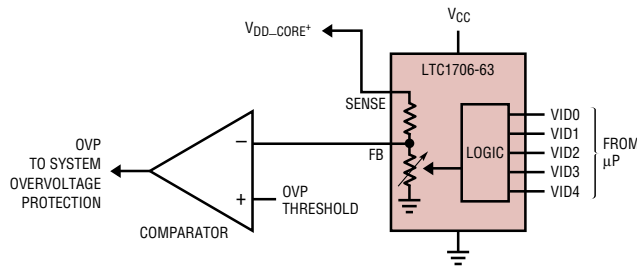

- C_{IN1}: SIX 10 μ F 16V CERAMIC CAPACITORS
- C_{OUT1}: TEN 22 μ F 6.3V CERAMIC CAPACITORS
- L1, L2: SUMIDA CEP125-1ROMC-H
- Q1, Q3: TWO SI7448DP IN PARALLEL
- Q2, Q4: THREE SI7448DP IN PARALLEL

1706-63 TA03

TYPICAL APPLICATION

1.025V to 1.4125V VID Programmable 15A Power Supply

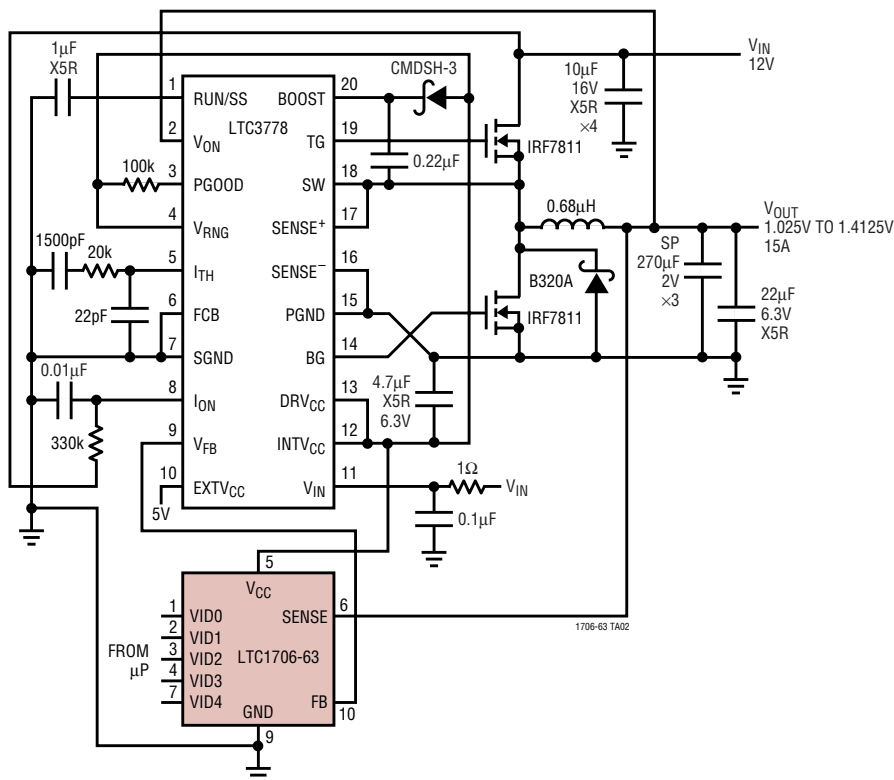

PACKAGE DESCRIPTION

MS Package
10-Lead Plastic MSOP
 (Reference LTC DWG # 05-08-1661)

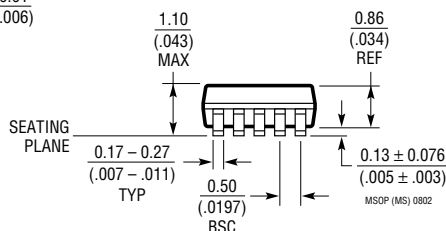
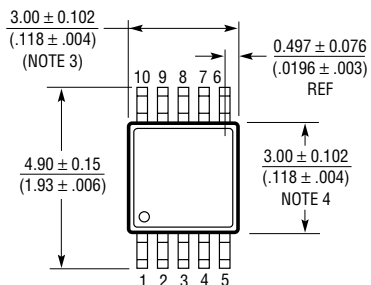
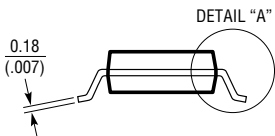
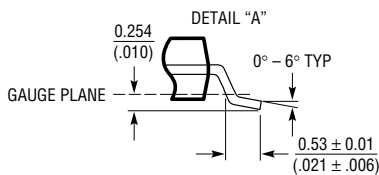
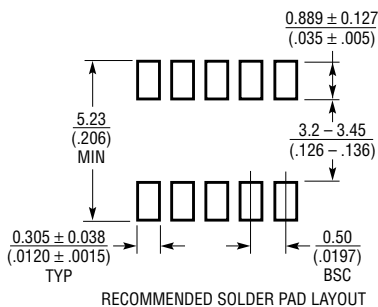

- NOTE:
- DIMENSIONS IN MILLIMETER/(INCH)
 - DRAWING NOT TO SCALE
 - DIMENSION DOES NOT INCLUDE MOLD FLASH, PROTRUSIONS OR GATE BURRS. MOLD FLASH, PROTRUSIONS OR GATE BURRS SHALL NOT EXCEED 0.152mm (.006") PER SIDE
 - DIMENSION DOES NOT INCLUDE INTERLEAD FLASH OR PROTRUSIONS. INTERLEAD FLASH OR PROTRUSIONS SHALL NOT EXCEED 0.152mm (.006") PER SIDE
 - LEAD COPLANARITY (BOTTOM OF LEADS AFTER FORMING) SHALL BE 0.102mm (.004") MAX

TYPICAL APPLICATION

VID Controlled High Current 70A 4-Phase Application

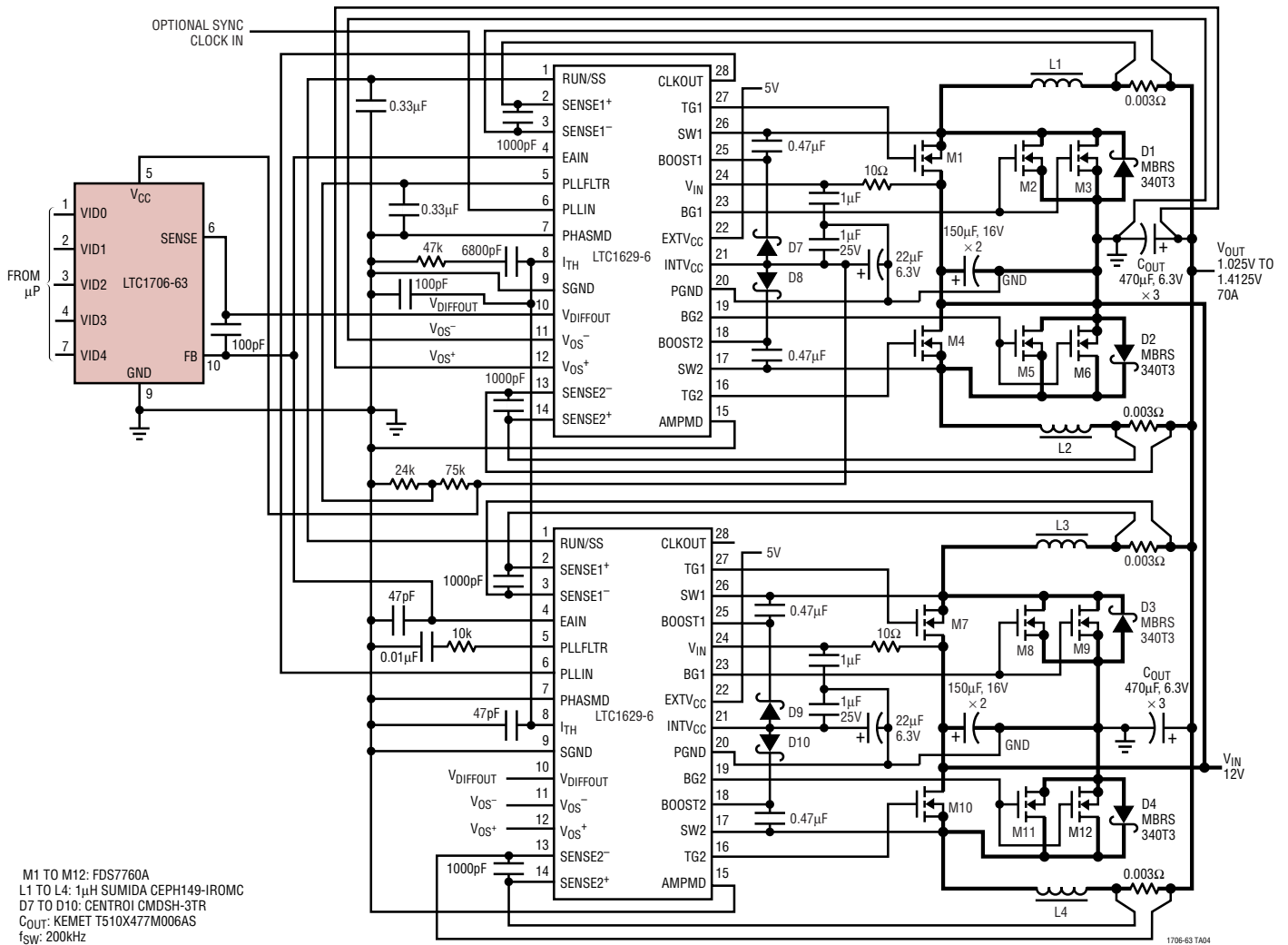

M1 TO M12: FDS7760A
 L1 TO L4: 1μH SUMIDA CEPH149-IROMC
 D7 TO D10: CENTROL CMDSH-3TR
 C_{OUT}: KEMET T510X477M006AS
 f_{sw}: 200kHz

RELATED PARTS

PART NUMBER	DESCRIPTION	COMMENTS
LTC1629-6	PolyPhase [®] Synchronous Step-Down Controller	Up to 12-Phase Operation, Up to 200A Power Supply
LTC3714	Single Phase Synchronous Step-Down Controller with VID	0.6V ≤ V _{OUT} ≤ 1.75V, I _{OUT} ≤ 25A
LTC3716	2-Phase Synchronous Step-Down Controller with VID	0.6V ≤ V _{OUT} ≤ 1.75V, I _{OUT} ≤ 40A
LTC3731	3-Phase, 60A Synchronous Step-Down Controller	Single IC 60A Solution with Onboard MOSFET Drivers, ±5% Output Current Matching for Optimum Thermal Performance and Reliability
LTC3733	3-Phase, 60A Synchronous Step-Down Controller for AMD Opteron Processors	On-Board VID and MOSFET Drivers, 0.8V ≤ V _{OUT} ≤ 1.55V, I _{OUT} ≤ 60A
LTC3778	Optional R _{SENSE} DC/DC Synchronous Controller	Current Mode Operation with R _{SENSE} or MOSFET R _{DC(ON)} Sensing, 4.5V ≤ V _{IN} ≤ 36V
LTC3819	2-Phase Synchronous Step-Down Controller	1.025V ≤ V _{OUT} ≤ 1.4125V; 40A

PolyPhase is a registered trademark of Linear Technology Corporation.