



数据手册



行业新闻



技术文章



工程师博客



企业招聘



专业图书



技术问答



关注微博



联系我们

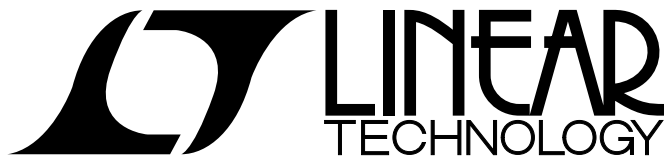

LTC1144

Switched-Capacitor Wide Input Range Voltage Converter with Shutdown

FEATURES

- **Wide Operating Supply Voltage Range: 2V to 18V**
- Boost Pin (Pin 1) for Higher Switching Frequency
- Simple Conversion of 15V to $-15V$ Supply
- Low Output Resistance: 120Ω Maximum
- Power Shutdown to $8\mu A$ with SHDN Pin
- Open Circuit Voltage Conversion Efficiency: 99.9% Typical
- Power Conversion Efficiency: 93% Typical
- Easy to Use

APPLICATIONS

- Conversion of 15V to $\pm 15V$ Supplies
- Inexpensive Negative Supplies
- Data Acquisition Systems
- High Voltage Upgrade to LTC1044 or 7660
- Voltage Division and Multiplications
- Automotive Applications
- Battery Systems with Wall Adapter/Charger

DESCRIPTION

The LTC1144 is a monolithic CMOS switched-capacitor voltage converter. It performs supply voltage conversion from positive to negative from an input range of 2V to 18V, resulting in complementary output voltages of $-2V$ to $-18V$. Only two noncritical external capacitors are needed for the charge pump and charge reservoir functions.

The converter has an internal oscillator that can be overdriven by an external clock or slowed down when connected to a capacitor. The oscillator runs at a 10kHz frequency when unloaded. A higher frequency outside the audio band can also be obtained if the Boost Pin is tied to V^+ . The SHDN pin reduces supply current to $8\mu A$ and can be used to save power when the converter is not in use.

The LTC1144 contains an internal oscillator, divide-by-two, voltage level shifter, and four power MOSFETs. A special logic circuit will prevent the power N-channel switch substrate from turning on.

TYPICAL APPLICATION

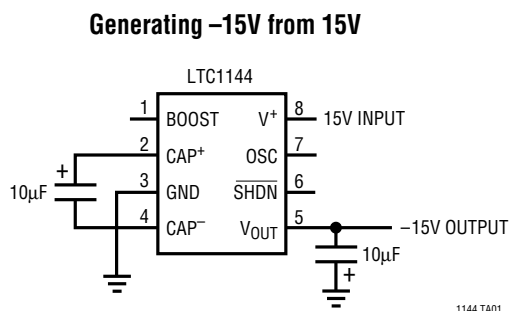

Output Voltage vs Load Current, $V^+ = 15V$

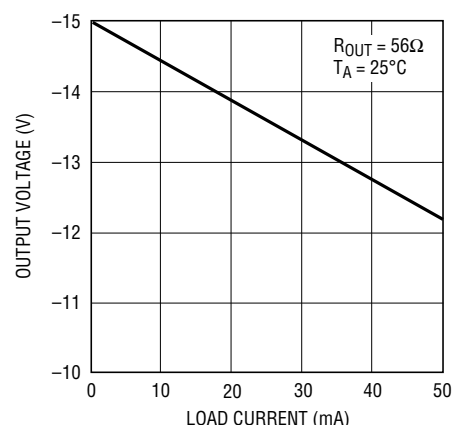

1144 TA02

LTC1144

ABSOLUTE MAXIMUM RATINGS

(Note 1)

Supply Voltage (V^+) (Transient)	20V
Supply Voltage (V^+) (Operating)	18V
Input Voltage on Pins 1, 6, 7 (Note 2)	$-0.3V < V_{IN} < (V^+) + 0.3V$
Output Short-Circuit Duration	
$V^+ \leq 10V$	Indefinite
$V^+ \leq 15V$	30 sec
$V^+ \leq 20V$	Not Protected
Power Dissipation	500mW
Operating Temperature Range	
LTC1144C	0°C to 70°C
LTC1144I	-40°C to 85°C
Storage Temperature Range	-65°C to 150°C
Lead Temperature (Soldering, 10 sec)	300°C

PACKAGE/ORDER INFORMATION

<p>N8 PACKAGE 8-LEAD PLASTIC DIP $T_{JMAX} = 110^\circ\text{C}$, $\theta_{JA} = 100^\circ\text{C/W}$</p>	ORDER PART NUMBER
	LTC1144CN8 LTC1144IN8
<p>S8 PACKAGE 8-LEAD PLASTIC SOIC $T_{JMAX} = 110^\circ\text{C}$, $\theta_{JA} = 130^\circ\text{C/W}$</p>	LTC1144CS8 LTC1144IS8
	S8 PART MARKING
	1144 1144I

Consult factory for Military grade parts.

ELECTRICAL CHARACTERISTICS

 $V^+ = 15V$, $C_{OSC} = 0pF$, $T_A = 25^\circ\text{C}$, Test Circuit Figure 1, unless otherwise noted.

SYMBOL	PARAMETER	CONDITIONS	LTC1144C			LTC1144I			UNITS
			MIN	TYP	MAX	MIN	TYP	MAX	
	Supply Voltage Range	$R_L = 10k$	●	2	18	2	18	V	
I_S	Supply Current	$R_L = \infty$, Pins 1, 6 No Connection, $f_{OSC} = 10kHz$	●		1.1 1.3		1.1 1.6	mA mA	
		$\overline{SHDN} = 0V$, $R_L = \infty$, Pins 1, 7 No Connection	●	0.008	0.03	0.008	0.035	mA	
		$V^+ = 5V$, $R_L = \infty$, Pins 1, 6 No Connection, $f_{OSC} = 4kHz$	●		0.10 0.13		0.10 0.15	mA mA	
		$V^+ = 5V$, $\overline{SHDN} = 0V$, $R_L = \infty$, Pins 1, 7 No Connection	●	0.002	0.015	0.002	0.018	mA	
R_{OUT}	Output Resistance	$V^+ = 15V$, $I_L = 20mA$ at 10kHz	●	56	100 120	56	100 140	Ω Ω	
		$V^+ = 5V$, $I_L = 3mA$ at 4kHz	●	90	250	90	300	Ω	
f_{OSC}	Oscillator Frequency	$V^+ = 15V$ (Note 3)		10		10		kHz	
		$V^+ = 5V$		4		4		kHz	
	Power Efficiency	$R_L = 2k$ at 10kHz	●	90	93	90	93	%	
	Voltage Conversion Efficiency	$R_L = \infty$	●	97.0	99.9	97.0	99.9	%	
	Oscillator Sink or Source Current	$V^+ = 5V$ ($V_{OSC} = 0V$ to $5V$) $V^+ = 15V$ ($V_{OSC} = 0V$ to $15V$)		0.5 4		0.5 4		μA μA	

The ● denotes specifications which apply over the full operating temperature range; all other limits and typicals at $T_A = 25^\circ\text{C}$.

Note 1: Absolute maximum ratings are those values beyond which the life of a device may be impaired.

Note 2: Connecting any input terminal to voltages greater than V^+ or less than ground may cause destructive latch-up. It is recommended that no

inputs from sources operating from external supplies be applied prior to power-up of the LTC1144.

Note 3: f_{OSC} is tested with $C_{OSC} = 100pF$ to minimize the effects of test fixture capacitance loading. The $0pF$ frequency is correlated to this $100pF$ test point, and is intended to simulate the capacitance at pin 7 when the device is plugged into a test socket and no external capacitor is used.

TYPICAL PERFORMANCE CHARACTERISTICS

Output Resistance vs Supply Voltage

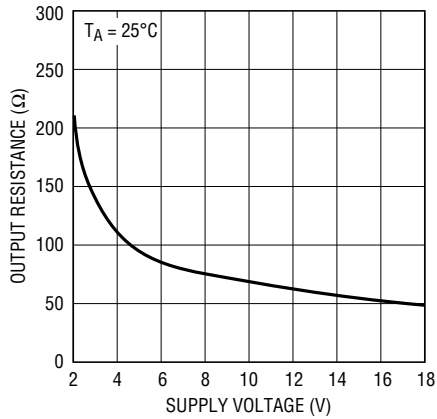

LTC1144 • TPC01

Output Resistance vs Temperature

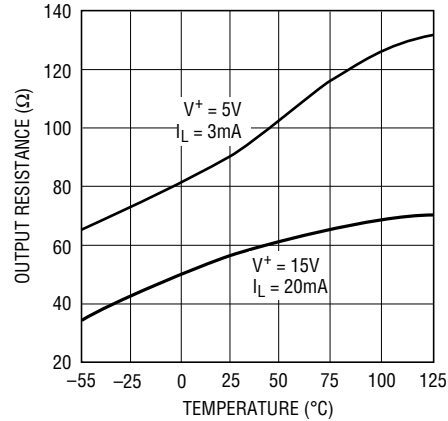

LTC1144 • TPC02

Oscillator Frequency vs Supply Voltage

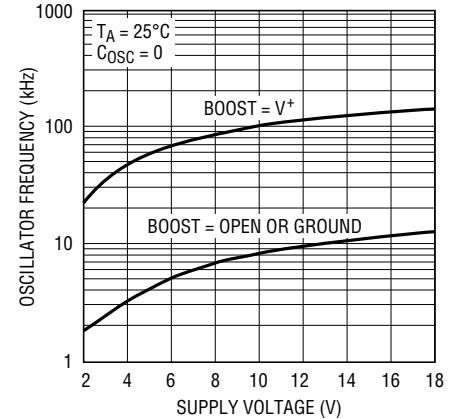

LTC1144 • TPC03

Oscillator Frequency as a Function of C_{OSC}

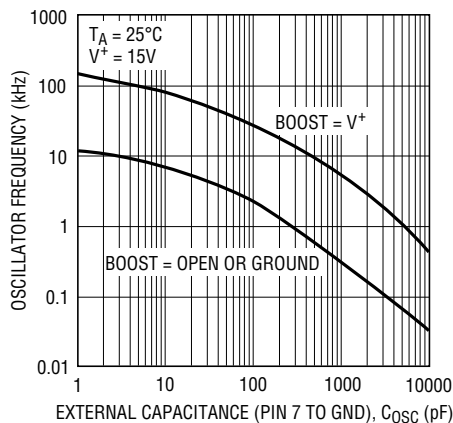

LTC1144 • TPC04

Oscillator Frequency vs Temperature

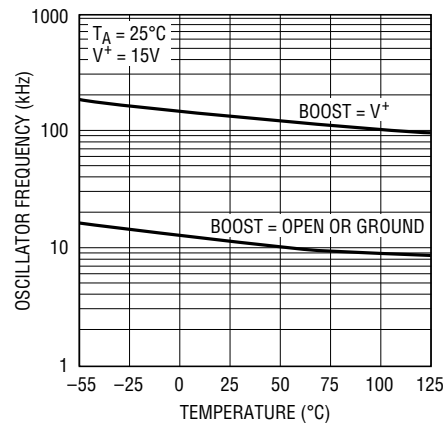

LTC1144 • TPC05

Output Voltage vs Load Current

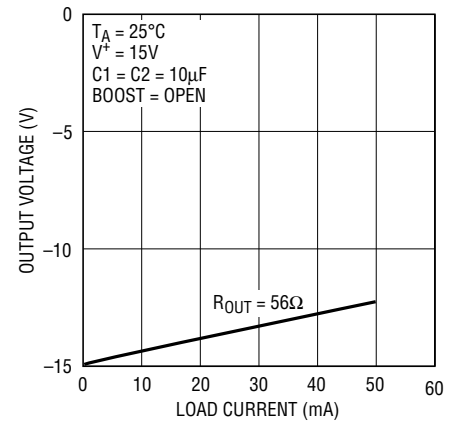

LTC1144 • TPC06

Output Voltage vs Load Current

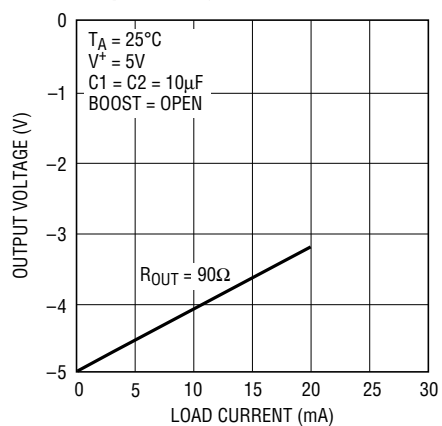

LTC1144 • TPC07

Supply Current as a Function of Oscillator Frequency

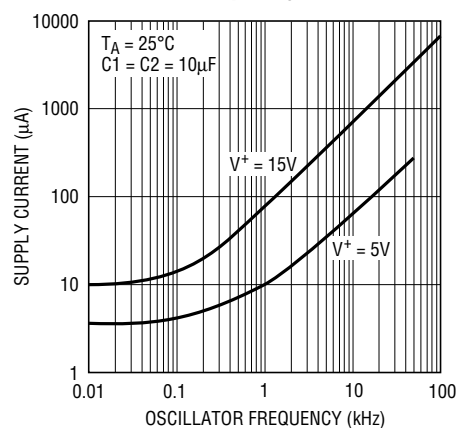

LTC1144 • TPC08

Power Conversion Efficiency and Supply Current vs Load Current

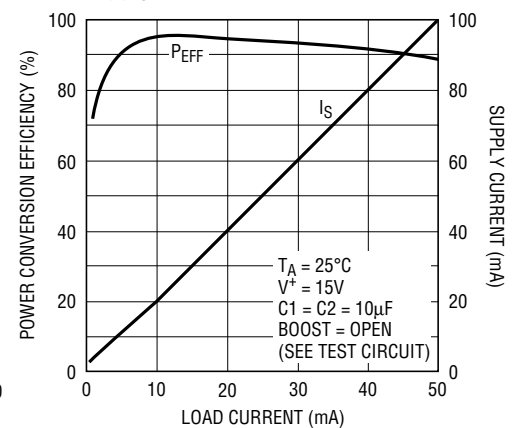

LTC1144 • TPC09

LTC1144

TYPICAL PERFORMANCE CHARACTERISTICS

Power Conversion Efficiency and Supply Current vs Load Current

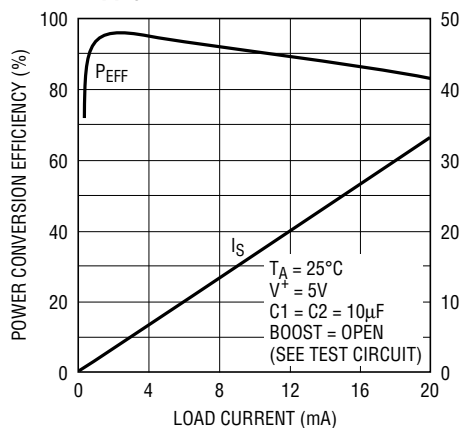

LTC1144 • TPC10

Power Conversion Efficiency vs Oscillator Frequency

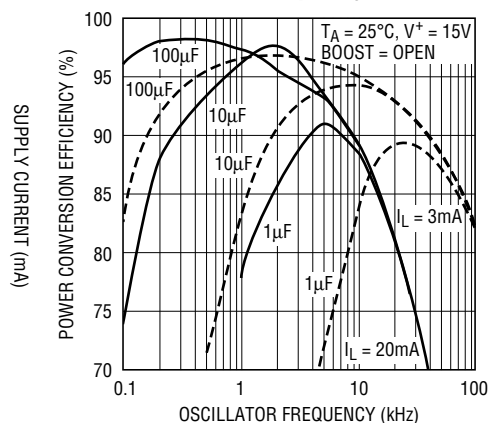

LTC1144 • TPC11

Output Resistance vs Oscillator Frequency

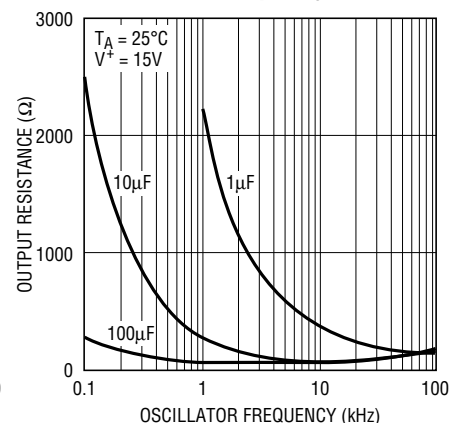

LTC1144 • TPC12

Ripple Voltage vs Load Current

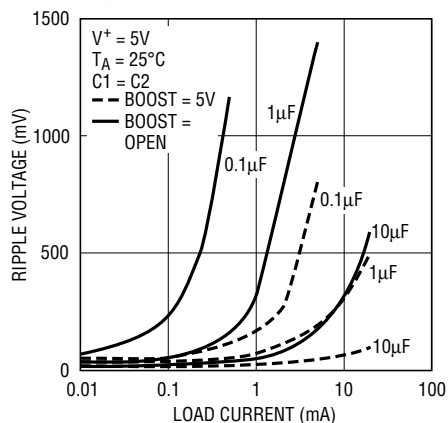

LTC1144 • TPC13

Output Voltage vs Load Current

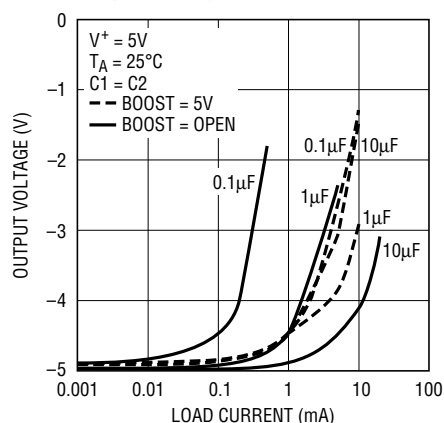

LTC1144 • G14

Output Voltage vs Load Current

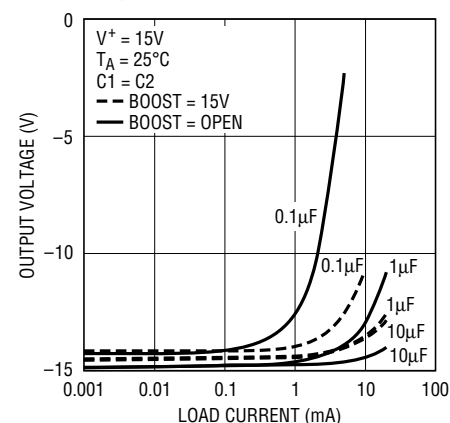

LTC1144 • TPC15

PIN FUNCTIONS

Boost (Pin 1): This pin will raise the oscillator frequency by a factor of 10 if tied high.

CAP⁺ (Pin 2): Positive Terminal for Pump Capacitor.

GND (Pin 3): Ground Reference.

CAP⁻ (Pin 4): Negative Terminal for Pump Capacitor.

V_{OUT} (Pin 5): Output of the Converter.

SHDN (Pin 6): Shutdown Pin. Tie to V⁺ pin or leave floating for normal operation. Tie to ground when in shutdown mode.

OSC (Pin 7): Oscillator Input Pin. This pin can be overdriven with an external clock or can be slowed down by connecting an external capacitor between this pin and ground.

V⁺ (Pin 8): Input Voltage.

TEST CIRCUIT

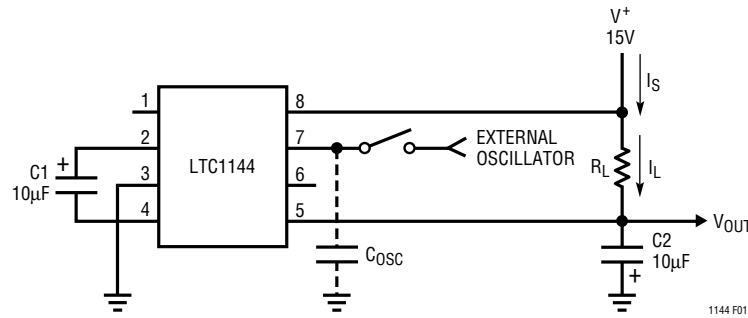

Figure 1.

APPLICATIONS INFORMATION

Theory of Operation

To understand the theory of operation of the LTC1144, a review of a basic switched-capacitor building block is helpful.

In Figure 2, when the switch is in the left position, capacitor C1 will charge to voltage V1. The total charge on C1 will be $q_1 = C_1V_1$. The switch then moves to the right, discharging C1 to voltage V2. After this discharge time, the charge on C1 is $q_2 = C_1V_2$. Note that charge has been transferred from the source V1 to the output V2. The amount of charge transferred is:

$$\Delta q = q_1 - q_2 = C_1(V_1 - V_2)$$

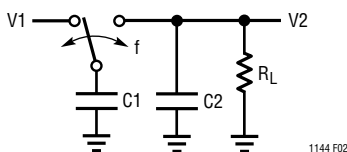

Figure 2. Switched-Capacitor Building Block

If the switch is cycled f times per second, the charge transfer per unit time (i.e., current) is:

$$I = f \times \Delta q = f \times C_1(V_1 - V_2)$$

Rewriting in terms of voltage and impedance equivalence,

$$I = \frac{V_1 - V_2}{\left(\frac{1}{f \times C_1}\right)} = \frac{V_1 - V_2}{R_{EQUIV}}$$

A new variable R_{EQUIV} has been defined such that $R_{EQUIV} = 1/(f \times C_1)$. Thus, the equivalent circuit for the switched-capacitor network is as shown in Figure 3.

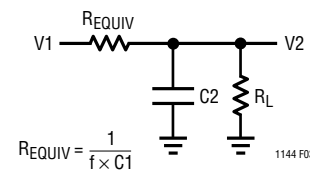

Figure 3. Switched-Capacitor Equivalent Circuit

Examination of Figure 4 shows that the LTC1144 has the same switching action as the basic switched-capacitor building block. With the addition of finite switch on-resistance and output voltage ripple, the simple theory, although not exact, provides an intuitive feel for how the device works.

For example, if you examine power conversion efficiency as a function of frequency (see Figure 5), this simple theory will explain how the LTC1144 behaves. The loss,

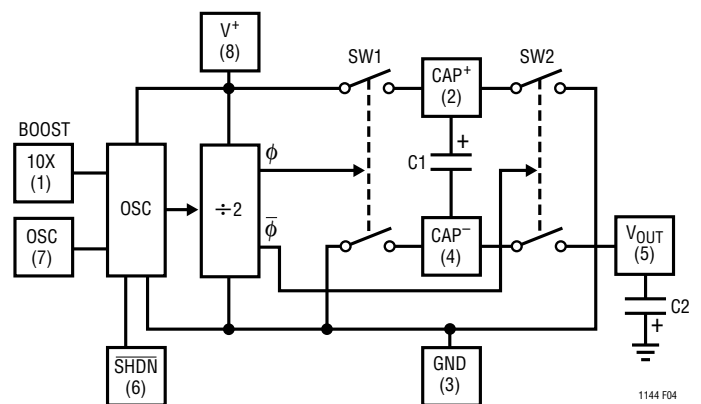

Figure 4. LTC1144 Switched-Capacitor Voltage Converter Block Diagram

LTC1144

APPLICATIONS INFORMATION

and hence the efficiency, is set by the output impedance. As frequency is decreased, the output impedance will eventually be dominated by the $1/(f \times C1)$ term and power efficiency will drop.

Note also that power efficiency decreases as frequency goes up. This is caused by internal switching losses which occur due to some finite charge being lost on each switching cycle. This charge loss per unit cycle, when multiplied by the switching frequency, becomes a current loss. At high frequency this loss becomes significant and the power efficiency starts to decrease.

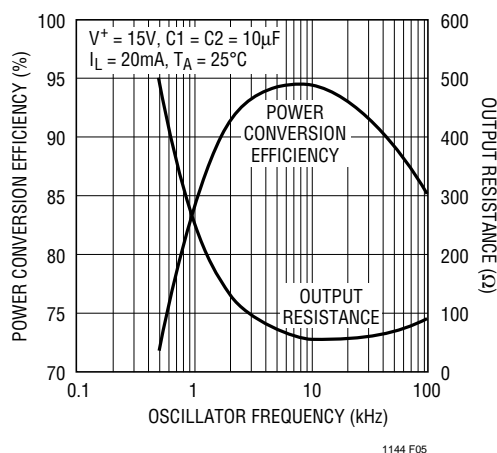

Figure 5. Power Conversion Efficiency and Output Resistance vs Oscillator Frequency

SHDN (Pin 6)

The LTC1144 has a \overline{SHDN} pin that will disable the internal oscillator when it is pulled low. The supply current will also drop to $8\mu A$.

OSC (Pin 7) and Boost (Pin 1)

The switching frequency can be raised, lowered or driven from an external source. Figure 6 shows a functional diagram of the oscillator circuit.

By connecting the boost pin (pin 1) to V^+ , the charge and discharge current is increased, and hence the frequency is increased by approximately 10 times. Increasing the frequency will decrease output impedance and ripple for higher load currents.

Loading pin 7 with more capacitance will lower the frequency. Using the boost (pin 1) in conjunction with exter-

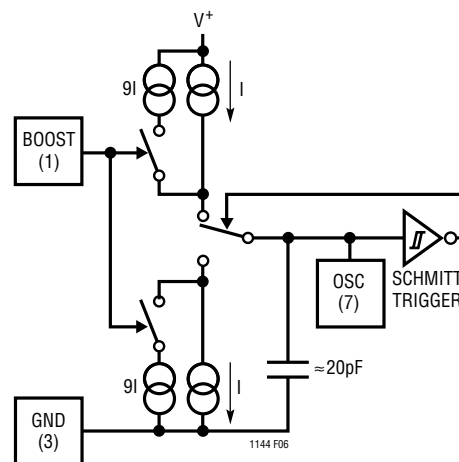

Figure 6. Oscillator

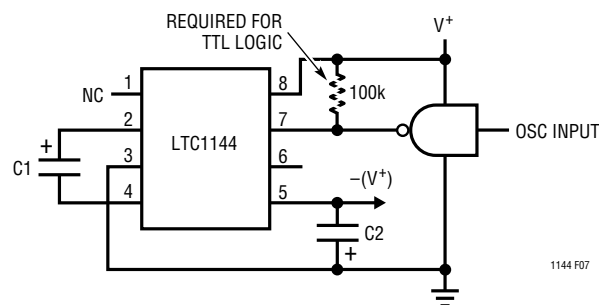

Figure 7. External Clocking

nal capacitance on pin 7 allows user selection of the frequency over a wide range.

Driving the LTC1144 from an external frequency source can be easily achieved by driving pin 7 and leaving the boost pin open as shown in Figure 7. The output current from pin 7 is small, typically $4\mu A$, so a logic gate is capable of driving this current. The choice of using a CMOS logic gate is best because it can operate over a wide supply voltage range (3V to 15V) and has enough voltage swing to drive the internal Schmitt trigger shown in Figure 6. For 5V applications, a TTL logic gate can be used by simply adding an external pull-up resistor (see Figure 7).

Capacitor Selection

External capacitors C1 and C2 are not critical. Matching is not required, nor do they have to be high quality or tight tolerance. Aluminum or tantalum electrolytics are excellent choices, with cost and size being the only consideration.

TYPICAL APPLICATIONS

Negative Voltage Converter

Figure 8 shows a typical connection which will provide a negative supply from an available positive supply. This circuit operates over full temperature and power supply ranges *without* the need of any external diodes.

The output voltage (pin 5) characteristics of the circuit are those of a nearly ideal voltage source in series with a 56Ω resistor. The 56Ω output impedance is composed of two terms: 1) the equivalent switched capacitor resistance (see Theory of Operation), and 2) a term related to the on-resistance of the MOS switches.

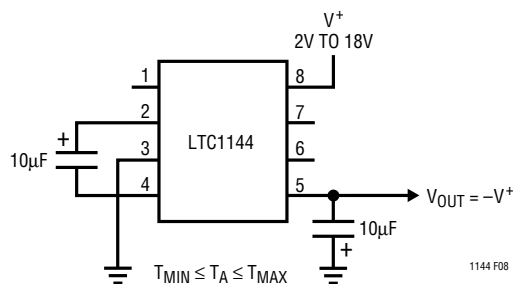

Figure 8. Negative Voltage Converter

At an oscillator frequency of 10kHz and $C1 = 10\mu\text{F}$, the first term is:

$$R_{\text{EQUIV}} = \frac{1}{(f_{\text{OSC}}/2) \times C1} = \frac{1}{5 \times 10^3 \times 10 \times 10^{-6}} = 20\Omega$$

Notice that the above equation for R_{EQUIV} is *not* a capacitive reactance equation ($X_C = 1/\omega C$) and does not contain a 2π term.

The exact expression for output impedance is extremely complex, but the dominant effect of the capacitor is clearly shown in Figure 5. For $C1 = C2 = 10\mu\text{F}$, the output impedance goes from 56Ω at $f_{\text{OSC}} = 10\text{kHz}$ to 250Ω at $f_{\text{OSC}} = 1\text{kHz}$. As the $1/(f \times C)$ term becomes large compared to the switch on-resistance term, the output resistance is determined by $1/(f \times C)$ only.

Voltage Doubling

Figure 9 shows a two-diode capacitive voltage doubler. With a 15V input, the output is 29.45V with no load and 28.18V with a 10mA load.

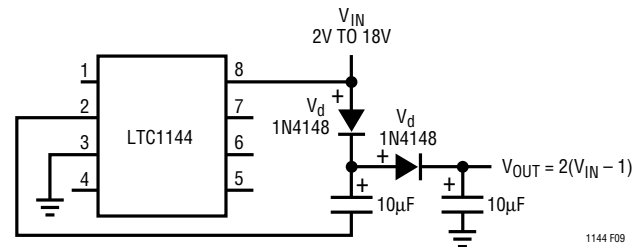

Figure 9. Voltage Doubler

Ultra-Precision Voltage Divider

An ultra-precision voltage divider is shown in Figure 10. To achieve the 0.0002% accuracy indicated, the load current should be kept below 100nA. However, with a slight loss in accuracy, the load current can be increased.

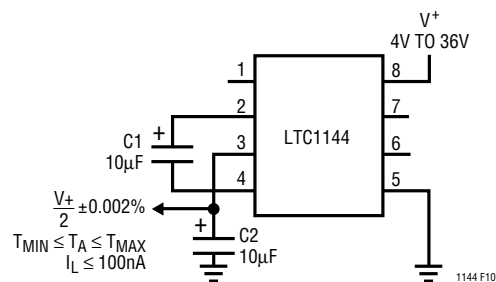

Figure 10. Ultra-Precision Voltage Divider

Battery Splitter

A common need in many systems is to obtain (+) and (-) supplies from a single battery or single power supply system. Where current requirements are small, the circuit shown in Figure 11 is a simple solution. It provides symmetrical \pm output voltages, both equal to one half the input voltage. The output voltages are both referenced to pin 3 (output common).

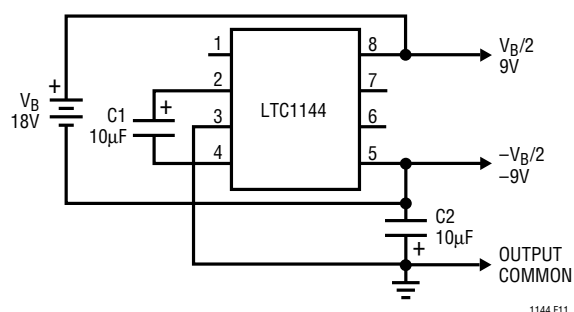

Figure 11. Battery Splitter

LTC1144

TYPICAL APPLICATIONS

Regulated -5V Output Voltage

Figure 12 shows a regulated -5V output with a 9V input. With a 0mA to 5mA load current, the R_{OUT} is below 20Ω .

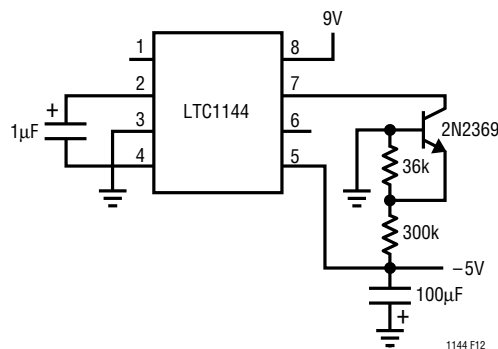

Figure 12. A Regulated -5V Supply

Paralleling for Lower Output Resistance

Additional flexibility of the LTC1144 is shown in Figure 13. Two LTC1144s are connected in parallel to provide a lower effective output resistance. However, if the output resistance is dominated by $1/(f \times C1)$, increasing the capacitor size ($C1$) or increasing the frequency will be of more benefit than the paralleling circuit shown.

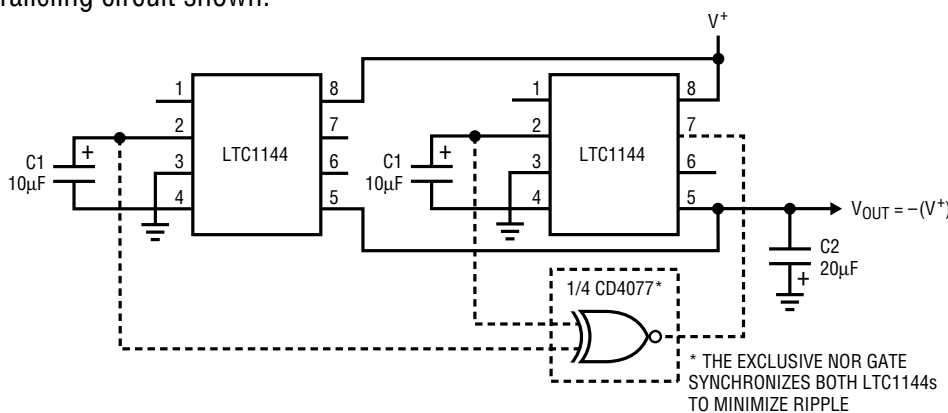
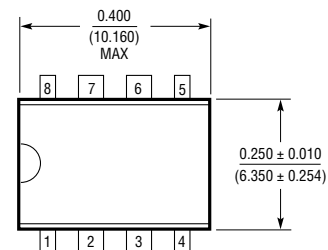
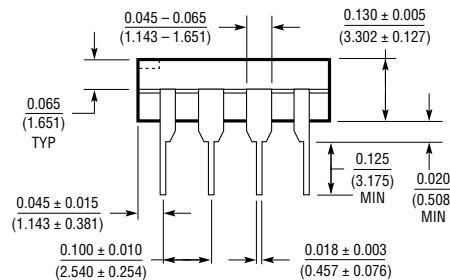
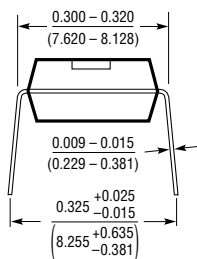

Figure 13. Paralleling for Lower Output Resistance

PACKAGE DESCRIPTION

Dimensions in inches (millimeters) unless otherwise noted.

N8 Package 8-Lead Plastic DIP



S8 Package 8-Lead Plastic SOIC

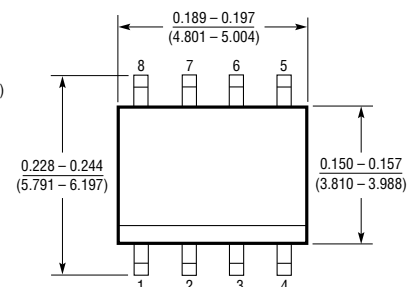
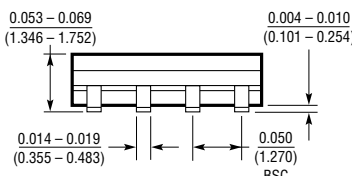
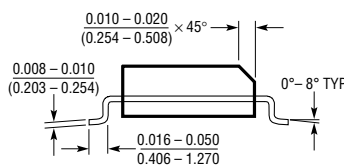

*THESE DIMENSIONS DO NOT INCLUDE MOLD FLASH OR PROTRUSIONS. MOLD FLASH OR PROTRUSIONS SHALL NOT EXCEED 0.006 INCH (0.15mm).