



UNISONIC TECHNOLOGIES CO., LTD

TL431

LINEAR INTEGRATED CIRCUIT

PROGRAMMABLE PRECISION REFERENCE

DESCRIPTION

The UTC TL431 is a three-terminal adjustable regulator with a guaranteed thermal stability over applicable temperature ranges. The output voltage may be set to any value between V_{REF} (approximately 2.5V) and 36 V with two external resistors. It provides very wide applications, including shunt regulator, series regulator, switching regulator, voltage reference and others.

FEATURES

- *Programmable output Voltage to 36V.
- *Low dynamic output impedance 0.2Ω .
- *Sink current capability of 1.0 to 100mA.
- *Equivalent full-range temperature coefficient of 50ppm/°C typical for operation over full rated operating temperature range.

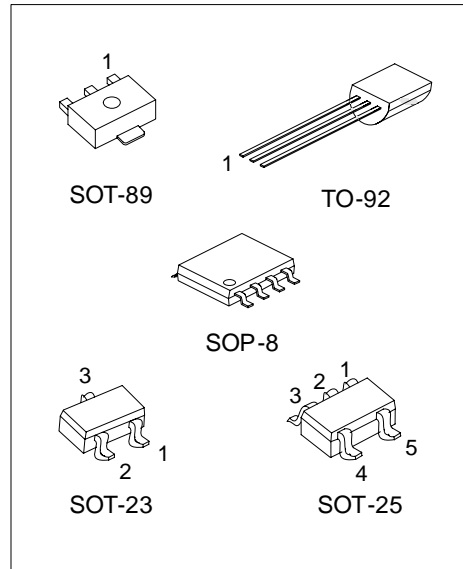

*Pb-free plating product number: TL431K
 *Pb-free plating product for SOT-23NS type number: TL431NSL

ORDERING INFORMATION

Order Number		Pin Assignment								Package	Packing
Normal	Lead Free Plating	1	2	3	4	5	6	7	8		
TL431-AB3-R	TL431K-AB3-R	R	A	K	-	-	-	-	-	SOT-89	Tape Reel
TL431-AE3-R	TL431K-AE3-R	K	R	A	-	-	-	-	-	SOT-23	Tape Reel
TL431NS-AE3-R	TL431NSL-AE3-R	R	K	A	-	-	-	-	-	SOT-23	Tape Reel
TL431-AF5-R	TL431K-AF5-R	X	X	K	R	A	-	-	-	SOT-25	Tape Reel
TL431-S08-R	TL431K-S08-R	K	A	A	X	X	A	A	R	SOP-8	Tape Reel
TL431-S08-T	TL431K-S08-T	K	A	A	X	X	A	A	R	SOP-8	Tube
TL431-T92-B	TL431K-T92-B	R	A	K	-	-	-	-	-	TO-92	Tape Box
TL431-T92-K	TL431K-T92-K	R	A	K	-	-	-	-	-	TO-92	Bulk
TL431-T92-R	TL431K-T92-R	R	A	K	-	-	-	-	-	TO-92	Tape Reel

Note: Pin Code: K: Cathode A: Anode R: Reference X: No Connection

<p>TL431K-AB3-R</p> <p>(1)Packing Type (2)Package Type (3)Lead Plating</p>	<p>(1) B: Tape Box, K: Bulk, R: Tape Reel, T: Tube (2) AB3: SOT-89, AE3: SOT-23, AF5: SOT-25, S08:SOP-8, T92: TO-92 (3) K: Lead Free Plating, Blank: Pb/Sn L: Lead Free Plating Only for SOT-23NS Type</p>
--	---

MARKING (SOT-23/SOT-25)

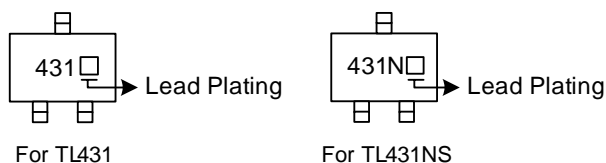

■ BLOCK DIAGRAM

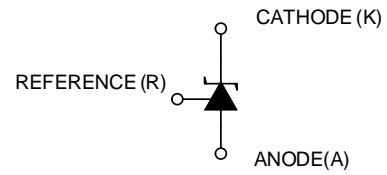
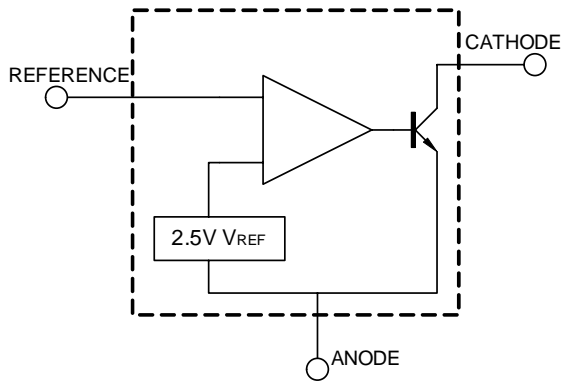

■ ABSOLUTE MAXIMUM RATINGS (Operating temperature range applies unless otherwise specified)

PARAMETER		SYMBOL	RATINGS	UNIT
Cathode Voltage		V_{KA}	37	V
Cathode Current Range(Continuous)		I_{KA}	-100 ~ +150	mA
Reference Input Current Range		I_{REF}	-0.05 ~ +10	mA
Power Dissipation	TO-92	P_D	770	mW
	SOT-89		800	mW
	SOT-23/SOT-25		300	mW
Operating Junction Temperature		T_J	+150	°C
Operating Ambient Temperature		T_{OPR}	-40 ~ +85	°C
Storage Temperature		T_{STG}	-65 ~ +150	°C

Note Absolute maximum ratings are those values beyond which the device could be permanently damaged. Absolute maximum ratings are stress ratings only and functional device operation is not implied.

■ RECOMMENDED OPERATING CONDITIONS

PARAMETER	SYMBOL	MIN	TYP	MAX	UNIT
Cathode Voltage	V_{KA}	V_{REF}		36	V
Cathode Current	I_{KA}	1		100	mA

■ ELECTRICAL CHARACTERISTICS ($T_C = 25$, unless otherwise specified.)

PARAMETER	SYMBOL	TEST CONDITIONS	MIN	TYP	MAX	UNIT
Reference Input Voltage	V_{REF}	$V_{KA} = V_{REF}, I_{KA} = 10mA$	2.470	2.495	2.520	V
Deviation of reference Input Voltage Over temperature	$\Delta V_{REF}/\Delta T$	$V_{KA} = V_{REF}, I_{KA} = 10mA$ $0^\circ C \quad T_a \quad 70^\circ C$		4.5	17	mV
Ratio of Change in Reference Input Voltage to the Change in Cathode Voltage	$\Delta V_{REF}/\Delta V_{KA}$	$I_{KA} = 10mA$ $\Delta V_{KA} = 10V \sim V_{REF}$ $\Delta V_{KA} = 36V \sim 10V$		-1.0 -0.5	-2.7 -2.0	mV/V
Reference Input Current	I_{REF}	$I_{KA} = 10mA, R1 = 10k\Omega, R2 = \infty$		1.5	4	μA
Deviation of Reference Input Current Over Full Temperature Range	$\Delta I_{REF}/\Delta T$	$I_{KA} = 10mA, R1 = 10k\Omega, R2 = \infty$ $T_a = \text{full Temperature}$		0.4	1.2	μA
Minimum Cathode Current for Regulation	$I_{KA(MIN)}$	$V_{KA} = V_{REF}$		0.45	1.0	mA
Off-State Cathode Current	$I_{KA(OFF)}$	$V_{KA} = 36V, V_{REF} = 0$		0.05	1.0	μA
Dynamic Impedance	Z_{KA}	$V_{KA} = V_{REF}, I_{KA} = 1 \text{ to } 100mA$ $f \leq 1.0kHz$		0.15	0.5	Ω

TYPICAL CHARACTERISTICS

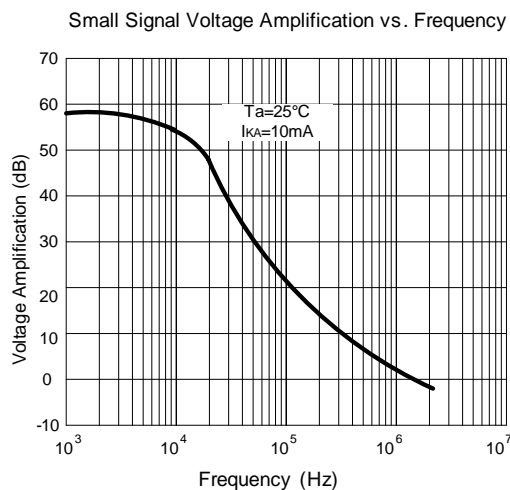
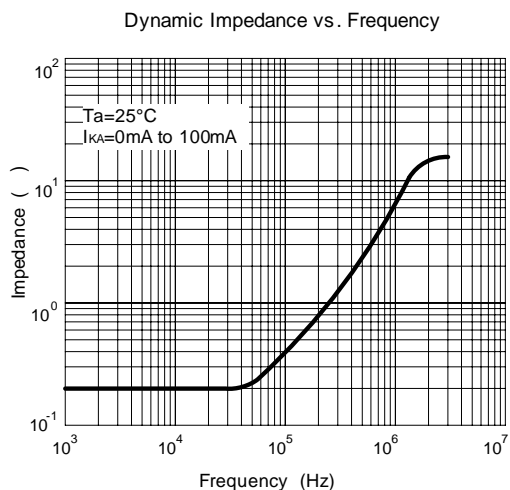
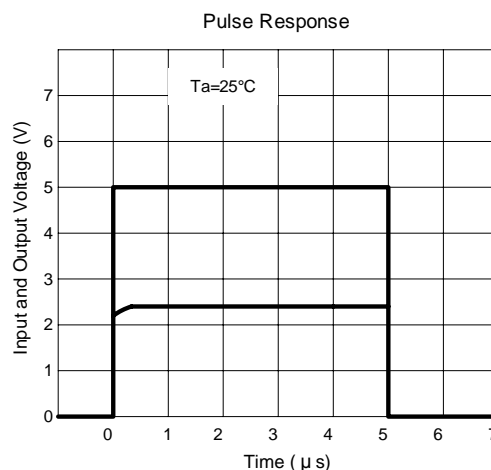
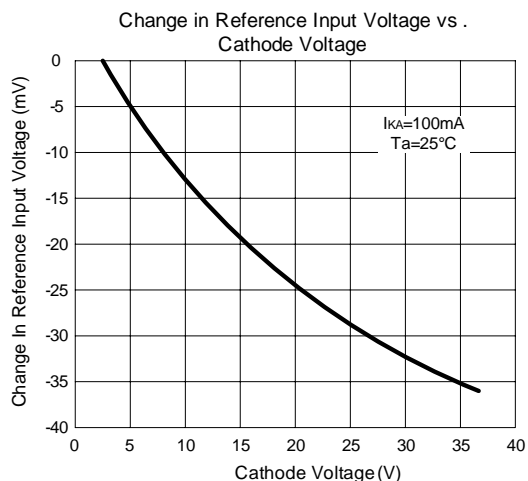
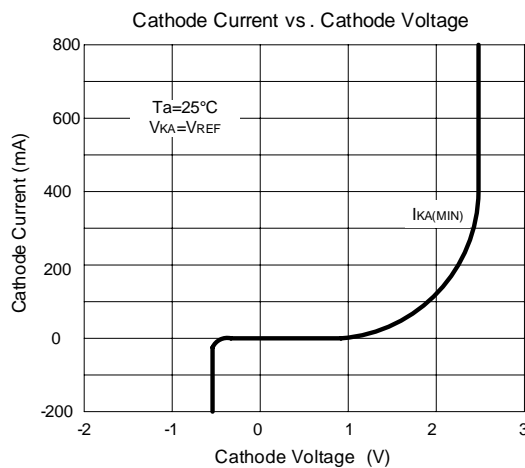
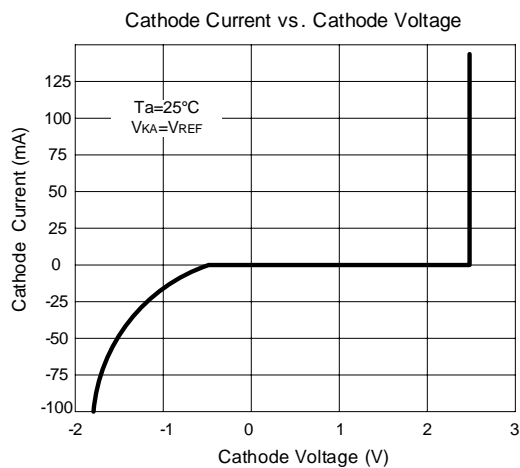

■ TYPICAL CHARACTERISTICS (Cont.)

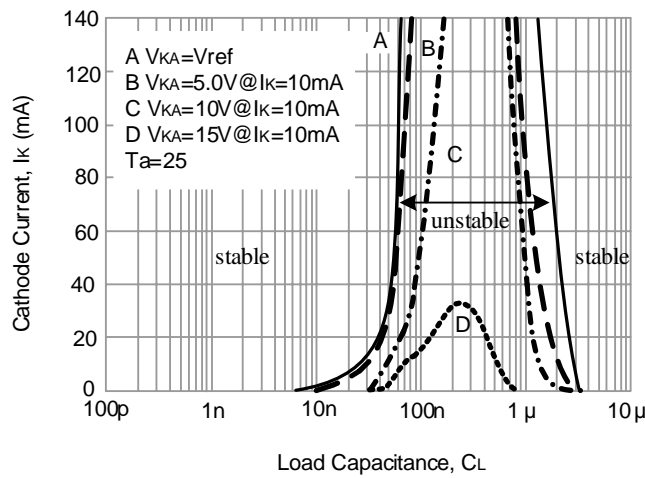
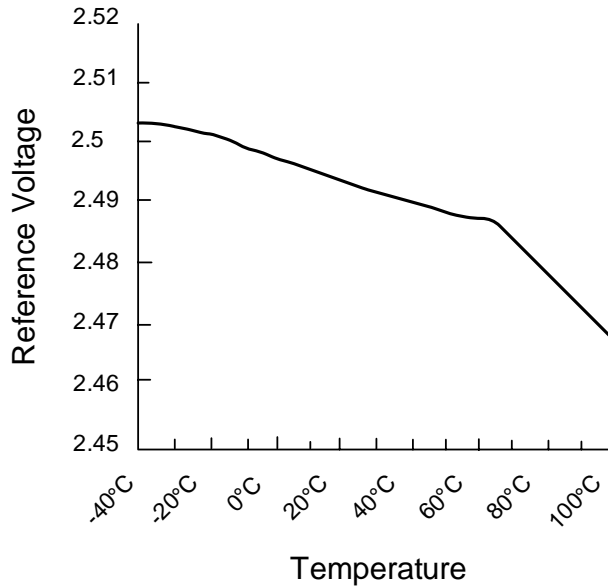

■ TEST CIRCUIT

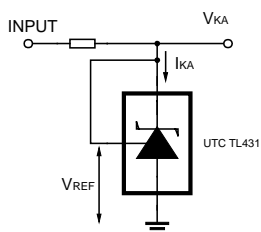

For $V_{KA} = V_{REF}$

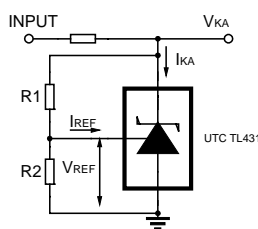

$$V_{KA} = V_{REF} \cdot (1 + R1/R2) + I_{REF} \cdot R1$$

For $V_{KA} = V_{REF} \cdot (1 + R1/R2) + I_{REF} \cdot R1$

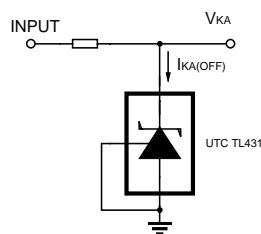

For $I_{KA(OFF)}$

■ APPLICATION CIRCUIT

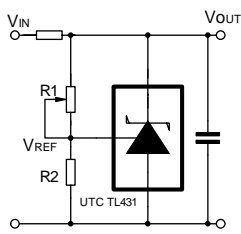

$$V_o = (1 + R1/R2) \cdot V_{REF}$$

Shutdown Regulator

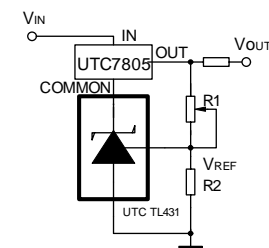

$$V_o = (1 + R1/R2) \cdot V_{REF}$$

Output Control of a Three-Terminal Fixed Regulator

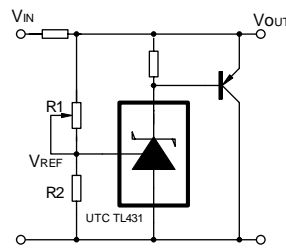

$$V_o = (1 + R1/R2) \cdot V_{REF}$$

Higher-current Shunt Regulator

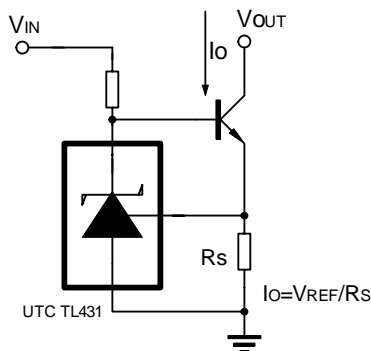

Constant-current Sink

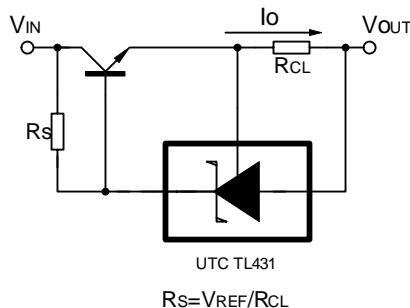

$$R_s = V_{REF} / R_{CL}$$

Current Limiting or Current Source

UTC assumes no responsibility for equipment failures that result from using products at values that exceed, even momentarily, rated values (such as maximum ratings, operating condition ranges, or other parameters) listed in products specifications of any and all UTC products described or contained herein. UTC products are not designed for use in life support appliances, devices or systems where malfunction of these products can be reasonably expected to result in personal injury. Reproduction in whole or in part is prohibited without the prior written consent of the copyright owner. The information presented in this document does not form part of any quotation or contract, is believed to be accurate and reliable and may be changed without notice.