

直流信號隔離傳送器 (DC SIGNAL ISOLATED TRANSMITTER)

MODEL
TD



特點(FEATURES)

- 精確度0.1%滿刻度 (Accuracy 0.1%F.S.)
- 多種輸入輸出選擇(Wide selection of input/output range)
- 輸入與輸出絕緣耐壓 2千伏特/1分鐘(Dielectric strength 2KVac/1 min.(input/output))
- 寬範圍交直流兩用電源設計(Wide input range for auxiliary power)
- 尺寸小,穩定性高(Dimension small & High stability)

1.MODEL:TD- (選購型號)

NO	Input Range	NO	Input Range	NO	Input Range	NO	Input Range	NO	Output Range	NO	Output Range	NO	Aux. Power
10	0-10mV	15	0-10V	20	0-1mA	25	4-20mA	A	0-50mV	F	0-1mA	A	AC/DC 18-60V
11	0-50mV	16	2-10V	21	0-10mA	29	SPECIFIED	B	0-1V	G	0-10mA	B	AC/DC 90-260V
12	0-1V	17	-10~+10V	22	0-20mA	Exciting DC24V(<25mA) (two-wire transmitter)		C	1-5V	H	0-20mA	C	AC110V(50/60Hz) ± 20%
13	0-5V	18	0-100V	23	4-20mA			D	0-10V	I	4-20mA	D	AC220V(50/60Hz) ± 20%
14	1-5V	19	0-200V	24	10-50mA			E	2-10V	R	SPECIFIED		Less 3VA for AC/DC input

2.SPCIFICATION (主要規格)

- Measuring accuracy : 0.1% F.S. (23 ± 5)
(精確度)
- Input resistance : >100Mohm (<2V range)
(輸入阻抗) >1Mohm (>2V range)
<10 ohm (current input)
- Maximum input : <300Vrms (>2V ranges)
(最大過載能力) <150Vrms (<2V ranges)
<150mA (current ranges)
- Response time : <250ms (0-90%)
(輸出反應時間)
- Output drive capability : <10mA for voltage mode
(輸出負載能力) <10V for current mode
- Output ripple(p-p) : <0.1% F.S.
(輸出漣波)
- Zero (offset) range : 0- ± 5% F.S.
(歸零調整範圍)
- Span (scale) range : 0- ± 10% F.S.
(最大值調整範圍)
- Temp. coefficient : 100ppm/ (0-50)
(溫度係數)
- Isolation : Input/Output/Power/Case
(隔離特性)
- Insulation Resistance : >100Mohm with 500V DC
(絕緣阻抗)
- Dielectric strength : 2KVac/1 min. (input/output/power)
(絕緣耐壓能力) 1600Vdc (input/output)
- Operating condition : 0-60 (20 to 90% RH non-condensed)
(使用環境條件)
- Storage condition : 0-70 (20 to 90% RH non-condensed)
(存放環境條件)
- Construction : Socket/plugin type with barrier terminals
(安裝方式)
- CE EMC Certification : EN 55022:1998/A1:2000 Class A
(CE 認證) EN 61000-3-2:2000
EN 61000-3-3:1995/A1:2001
EN 55024:1998/A1:2001

3.TERMINAL CONNECTION (接線圖)

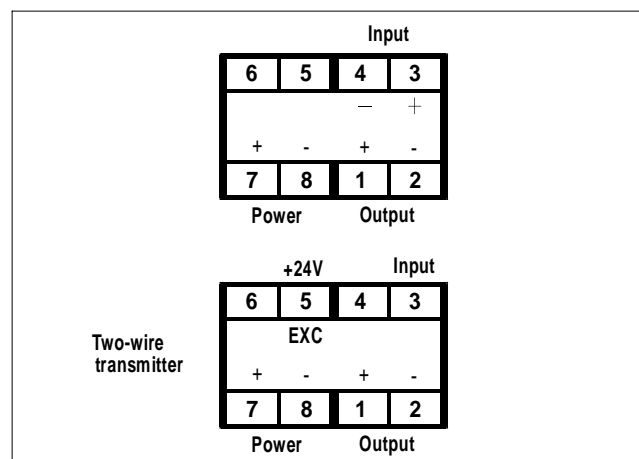

4.DIMENSION(unit:mm) (外型尺寸)

