

## LOW POWER DC/DC BOOST CONVERTER IN SOT-23 PACKAGE

### FEATURES

- 1.8 V to 6 V Input Voltage Range
- Adjustable Output Voltage Range up to 28 V
- 400 mA (TPS61040) and 250 mA (TPS61041) Internal Switch Current
- Up to 1 MHz Switching Frequency
- 28  $\mu$ A Typical No Load Quiescent Current
- 1  $\mu$ A Typical Shutdown Current
- Internal Softstart
- Available in a Tiny 5-Pin SOT23 Package

### APPLICATIONS

- LCD Bias Supply
- White-LED Supply for LCD Backlights
- Digital Still Camera
- PDAs, Organizers and Handheld PCs
- Cellular Phones
- Internet Audio Player
- Standard 3.3 V/5 V to 12 V Conversion

### DESCRIPTION

The TPS61040/41 is a high-frequency boost converter dedicated for small to medium LCD bias supply and white LED backlight supplies. The device is ideal to generate output voltages up to 28 V from a dual cell NiMH/NiCd or a single cell Li-Ion battery. The part can also be used to generate standard 3.3 V/5 V to 12 V power conversions.

The TPS61040/41 operates with a switching frequency up to 1 MHz. This allows the use of small external components using ceramic as well as tantalum output capacitors. Together with the tiny SOT23 package, the TPS61040/41 gives a very small overall solution size. The TPS61040 has an internal 400 mA switch current limit, while the TPS61041 has a 250 mA switch current limit, offering lower output voltage ripple and allows the use of a smaller form factor inductor for lower power applications. The low quiescent current (typically 28  $\mu$ A) together with an optimized control scheme, allows device operation at very high efficiencies over the entire load current range.

### TYPICAL APPLICATION

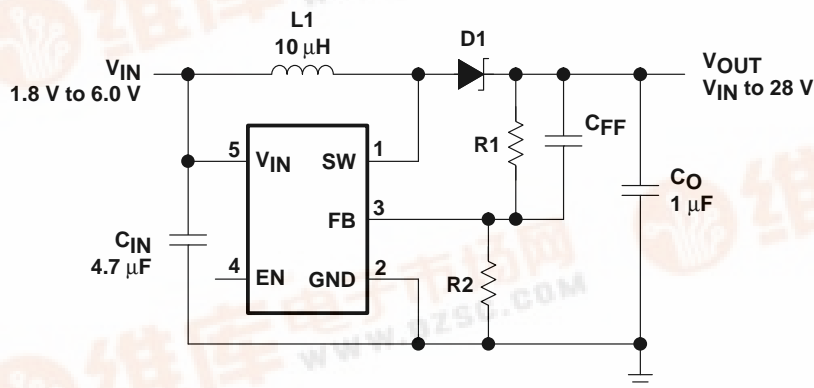

EFFICIENCY  
vs  
OUTPUT CURRENT

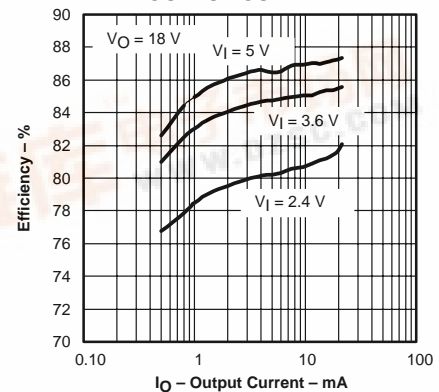

Please be aware that an important notice concerning availability, standard warranty, and use in critical applications of Texas Instruments semiconductor products and disclaimers thereto appears at the end of this data sheet.

# TPS61040 TPS61041

SLVS413 – FEBRUARY 2002

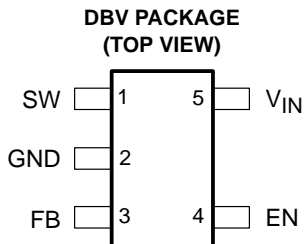

**Ordering Information†**

T <sub>A</sub>	SWITCH CURRENT LIMIT	SOT23 PACKAGE (DBV)	PACKAGE MARKING
-40 to 85°C	400 mA	TPS61040DBV	PHOI
	250 mA	TPS61041DBV	PHPI

† The DBV package is available in tape & reel. Add "R" suffix (DBVR) to order quantities of 3000 parts. Add "T" suffix (DBVT) to order quantities of 250 parts.

## functional block diagram

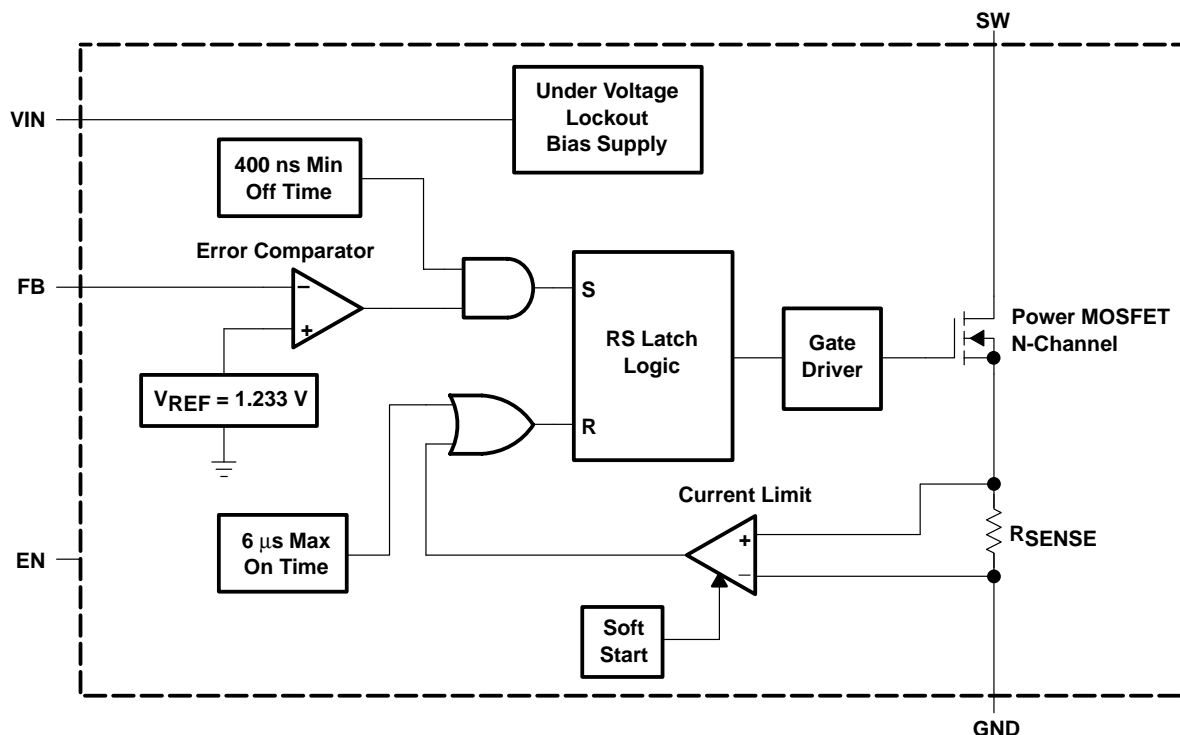

## Terminal Functions

TERMINAL NAME	NO.	I/O	DESCRIPTION
SW	1	I	Connect the inductor and the Schottky diode to this pin. This is the switch pin and is connected to the drain of the internal power MOSFET.
GND	2		Ground
FB	3	I	This is the feedback pin of the device. Connect this pin to the external voltage divider to program the desired output voltage.
EN	4	I	This is the enable pin of the device. Pulling this pin to ground forces the device into shutdown mode reducing the supply current to less than 1 µA. This pin should not be left floating and needs to be terminated.
VIN	5	I	Supply voltage pin

## detailed description

### operation

The TPS61040/41 operates with an input voltage range of 1.8 V to 6 V and can generate output voltages up to 28 V. The device operates in a pulse frequency modulation (PFM) scheme with constant peak current control. This control scheme maintains high efficiency over the entire load current range, and with a switching frequency up to 1 MHz, the device enables the use of very small external components.

The converter monitors the output voltage, and as soon as the feedback voltage falls below the reference voltage of typically 1.233 V, the internal switch turns on and the current ramps up. The switch turns off as soon as the inductor current reaches the internally set peak current of typically 400 mA (TPS61040) or 250 mA (TPS61041). Refer to the section *peak current control* for more information. The second criteria that turns off the switch is the maximum on-time of 6  $\mu$ s (typical). This is just to limit the maximum on-time of the converter to cover for extreme conditions. As the switch is turned off the external Schottky diode is forward biased delivering the current to the output. The switch remains off for a minimum of 400 ns (typical), or until the feedback voltage drops below the reference voltage again. Using this PFM peak current control scheme the converter operates in discontinuous conduction mode (DCM) where the switching frequency depends on the output current, which results in very high efficiency over the entire load current range. This regulation scheme is inherently stable, allowing a wider selection range for the inductor and output capacitor.

### peak current control

The internal switch turns on until the inductor current reaches the typical dc current limit ( $I_{LIM}$ ) of 400 mA (TPS61040) or 250 mA (TPS61041). Due to the internal propagation delay of typical 100 ns, the actual current exceeds the dc current limit threshold by a small amount. The typical peak current limit can be calculated:

$$I_{\text{peak(typ)}} = I_{LIM} + \frac{V_{in}}{L} \times 100 \text{ ns}$$

$$I_{\text{peak(typ)}} = 400 \text{ mA} + \frac{V_{in}}{L} \times 100 \text{ ns for the TPS61040}$$

$$I_{\text{peak(typ)}} = 250 \text{ mA} + \frac{V_{in}}{L} \times 100 \text{ ns for the TPS61041}$$

The higher the input voltage and the lower the inductor value, the greater the peak.

By selecting the TPS61040 or TPS61041, it is possible to tailor the design to the specific application current limit requirements. A lower current limit supports applications requiring lower output power and allows the use of an inductor with a lower current rating and a smaller form factor. A lower current limit usually has a lower output voltage ripple as well.

### softstart

All inductive step-up converters exhibit high inrush current during start-up if no special precaution is made. This can cause voltage drops at the input rail during start up and may result in an unwanted or early system shut down.

The TPS61040/41 limits this inrush current by increasing the current limit in two steps starting from  $\frac{I_{LIM}}{4}$  for 256 cycles to  $\frac{I_{LIM}}{2}$  for the next 256 cycles, and then full current limit (refer to Figure 14).

# TPS61040 TPS61041

SLVS413 – FEBRUARY 2002

## detailed description (continued)

### enable

Pulling the enable (EN) to ground shuts down the device reducing the shutdown current to 1  $\mu$ A (typical). Since there is a conductive path from the input to the output through the inductor and Schottky diode, the output voltage is equal to the input voltage during shutdown. The enable pin needs to be terminated and should not be left floating. Using a small external transistor disconnects the input from the output during shutdown as shown in Figure 18.

### undervoltage lockout

An undervoltage lockout prevents misoperation of the device at input voltages below typical 1.5 V. When the input voltage is below the undervoltage threshold the main switch is turned off.

## absolute maximum ratings over operating free-air temperature (unless otherwise noted)<sup>†</sup>

Supply voltages on pin VIN (see Note 1)	−0.3 V to 7 V
Voltages on pins EN, FB (see Note 1)	−0.3 V to $V_{IN} + 0.3$ V
Switch voltage on pin SW (see Note 1)	30 V
Continuous power dissipation	See Dissipation Rating Table
Operating junction temperature, $T_J$	−40°C to 150°C
Storage temperature, $T_{Stg}$	−65°C to 150°C
Lead temperature (soldering 10 seconds)	260°C

<sup>†</sup> Stresses beyond those listed under “absolute maximum ratings” may cause permanent damage to the device. These are stress ratings only, and functional operation of the device at these or any other conditions beyond those indicated under “recommended operating conditions” is not implied. Exposure to absolute-maximum-rated conditions for extended periods may affect device reliability.

NOTE 1: All voltage values are with respect to network ground terminal.

DISSIPATION RATING TABLE

PACKAGE	$T_A \leq 25^\circ\text{C}$ POWER RATING	DERATING FACTOR ABOVE $T_A = 25^\circ\text{C}$	$T_A = 70^\circ\text{C}$ POWER RATING	$T_A = 85^\circ\text{C}$ POWER RATING
DBV	357 mW	3.5 mW/°C	192 mW	140 mW

NOTE: The thermal resistance junction to ambient of the 5-pin SOT23 is 250°C/W.

## recommended operating conditions

	MIN	TYP	MAX	UNIT
Input voltage range, $V_{in}$	1.8		6	V
Output voltage range, $V_{OUT}$			28	V
Inductor (see Note 2), L	2.2	10		$\mu$ H
Switching frequency (see Note 2), f			1	MHz
Input capacitor (see Note 2), $C_{in}$		4.7		$\mu$ F
Output capacitor (see Note 2), $C_{OUT}$	1			$\mu$ F
Operating ambient temperature, $T_A$	−40		85	°C
Operating junction temperature, $T_J$	−40		125	°C

NOTE 2: Refer to application section for further information

electrical characteristics,  $V_{in} = 2.4\text{ V}$ ,  $EN = VIN$ ,  $T_A = -40^\circ\text{C}$  to  $85^\circ\text{C}$ , typical values are at  $T_A = 25^\circ\text{C}$  (unless otherwise noted)

supply current

PARAMETER	TEST CONDITIONS	MIN	TYP	MAX	UNIT
$V_{in}$ Input voltage range		1.8		6	V
$I_Q$ Operating quiescent current	$I_{OUT} = 0\text{ mA}$ , not switching, $V_{FB} = 1.3\text{ V}$		28	50	$\mu\text{A}$
$I_{SD}$ Shutdown current	$EN = GND$		0.1	1	$\mu\text{A}$
$V_{UVLO}$ Under-voltage lockout threshold			1.5	1.7	V

enable

PARAMETER	TEST CONDITIONS	MIN	TYP	MAX	UNIT
$V_{IH}$ EN high level input voltage		1.3			V
$V_{IL}$ EN low level input voltage				0.4	V
$I_I$ EN input leakage current	$EN = GND$ or $VIN$		0.1	1	$\mu\text{A}$

power switch and current limit

PARAMETER	TEST CONDITIONS	MIN	TYP	MAX	UNIT
$V_{sw}$ Maximum switch voltage				30	V
$t_{off}$ Minimum off time		250	400	550	ns
$t_{on}$ Maximum on time		4	6	7.5	$\mu\text{s}$
$R_{DS(ON)}$ MOSFET on-resistance	$V_{in} = 2.4\text{ V}$ ; $I_{sw} = 200\text{ mA}$ ; TPS61040		600	1000	$\text{m}\Omega$
$R_{DS(ON)}$ MOSFET on-resistance	$V_{in} = 2.4\text{ V}$ ; $I_{sw} = 200\text{ mA}$ ; TPS61041		750	1250	$\text{m}\Omega$
MOSFET leakage current	$V_{sw} = 28\text{ V}$		1	10	$\mu\text{A}$
$I_{LIM}$ MOSFET current limit	TPS61040	350	400	450	mA
$I_{LIM}$ MOSFET current limit	TPS61041	215	250	285	mA

output

PARAMETER	TEST CONDITIONS	MIN	TYP	MAX	UNIT
$V_{OUT}$ Adjustable output voltage range		$V_{in}$		28	V
$V_{ref}$ Internal voltage reference			1.233		V
$I_{FB}$ Feedback input bias current	$V_{FB} = 1.3\text{ V}$			1	$\mu\text{A}$
$V_{FB}$ Feedback trip point voltage	$1.8\text{ V} \leq V_{in} \leq 6.0\text{ V}$	1.208	1.233	1.258	V
Line regulation (see Note 3)	$1.8\text{ V} \leq V_{in} \leq 6.0\text{ V}$ ; $V_{out} = 18\text{ V}$ ; $I_{load} = 10\text{ mA}$ $C_{ff} = \text{not connected}$		0.05		%/V
Load regulation (see Note 3)	$V_{in} = 2.4\text{ V}$ ; $V_{out} = 18\text{ V}$ ; $0\text{ mA} \leq I_{out} \leq 30\text{ mA}$		0.15		%/mA

NOTE 3: The line and load regulation depend on the external component selection. Refer to the application section for further information.

TYPICAL CHARACTERISTICS

Table of Graphs

		FIGURE	
$\eta$	Efficiency	vs Load current	1, 2, 3
		vs Input voltage	4
$I_Q$	Quiescent current	vs Input voltage and temperature	5
$V_{FB}$	Feedback voltage	vs Temperature	6
$I_{SW}$	Switch current limit	vs Temperature	7
$I_{CL}$	Switch current limit	vs Supply voltage, TPS61041	8
		vs Supply voltage, TPS61040	9
$R_{DSon}$	$R_{DSon}$	vs Temperature	10
		vs Supply voltage	11
	Line transient response		12
	Load transient response		13
	Start Up behavior		14

EFFICIENCY  
vs  
OUTPUT CURRENT

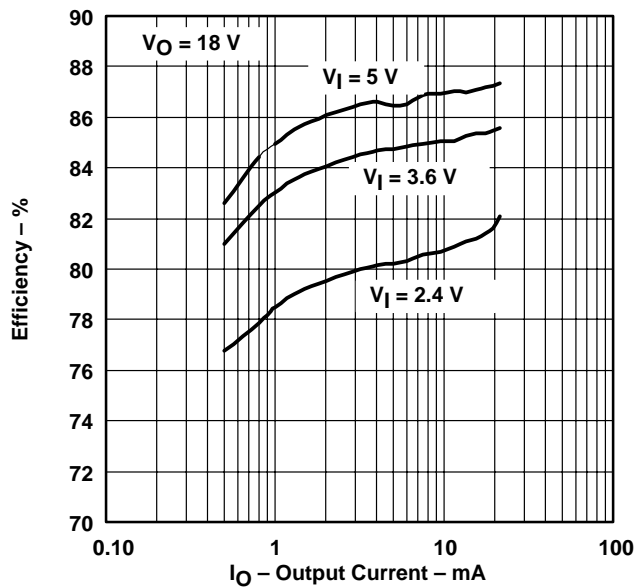

Figure 1

EFFICIENCY  
vs  
LOAD CURRENT

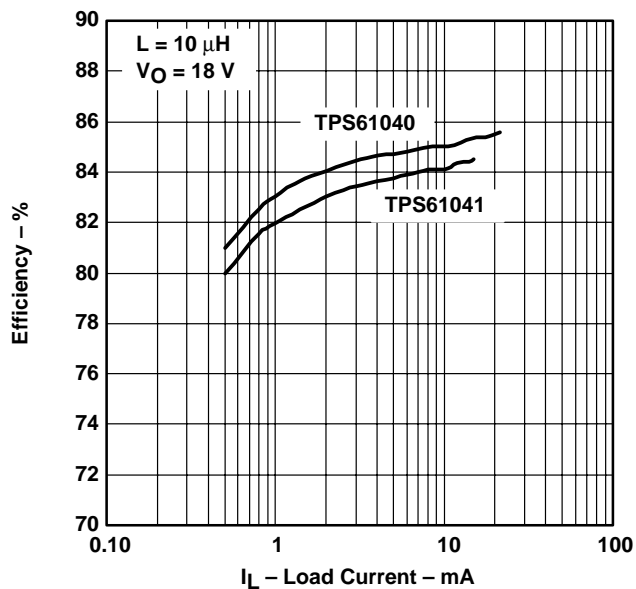

Figure 2

TYPICAL CHARACTERISTICS

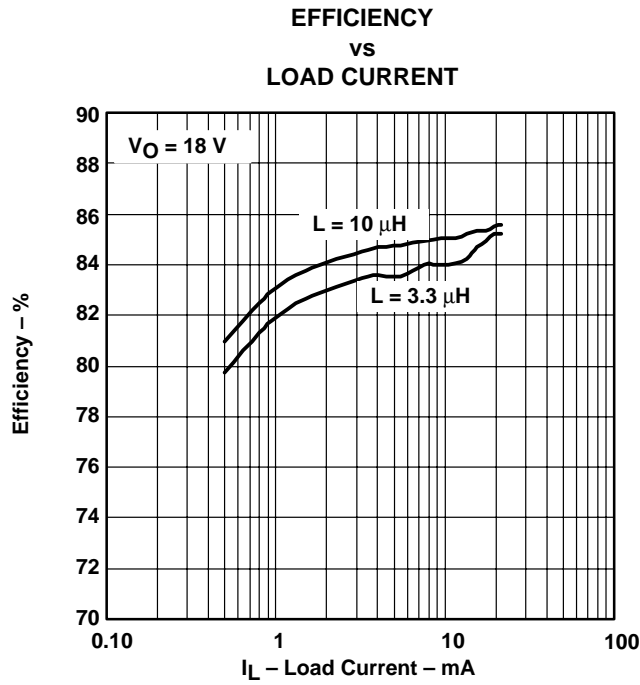

Figure 3

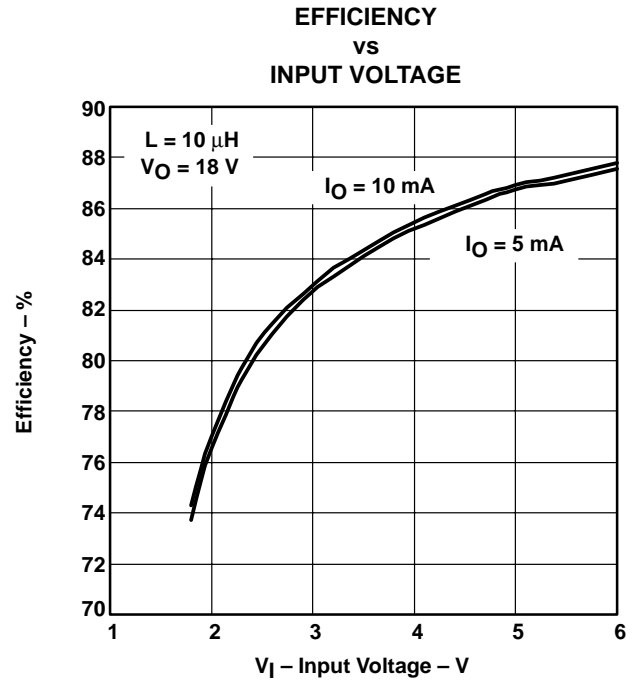

Figure 4

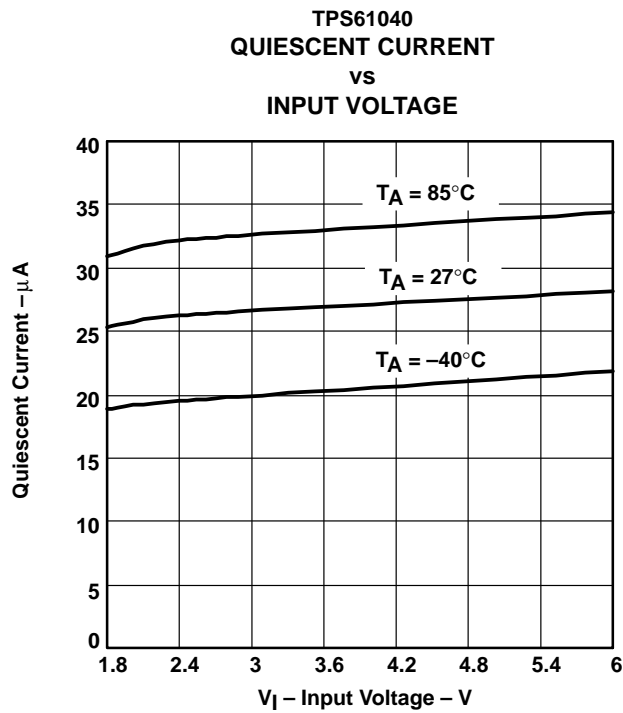

Figure 5

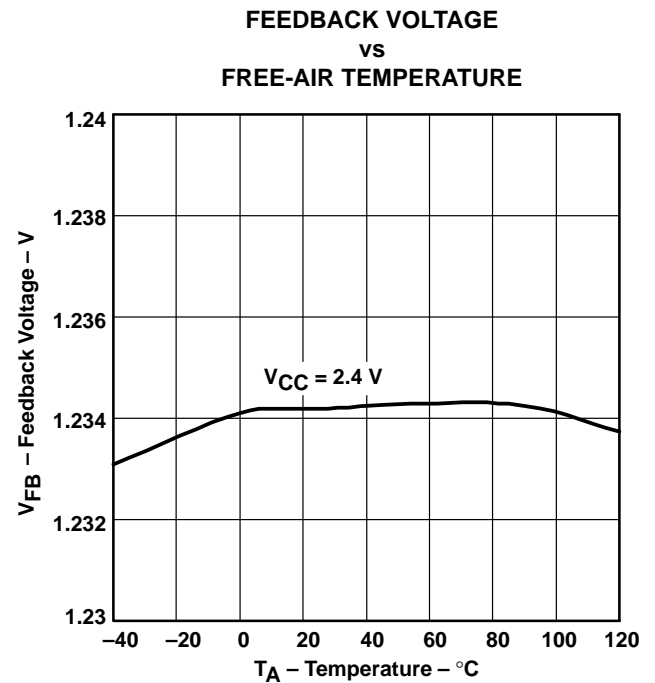

Figure 6

TYPICAL CHARACTERISTICS

TPS61040/41  
SWITCH CURRENT LIMIT  
vs  
FREE-AIR TEMPERATURE

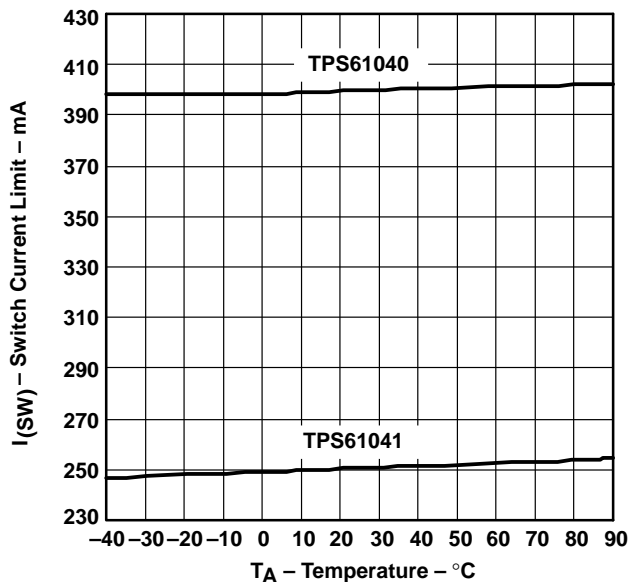

Figure 7

TPS61041  
CURRENT LIMIT  
vs  
SUPPLY VOLTAGE

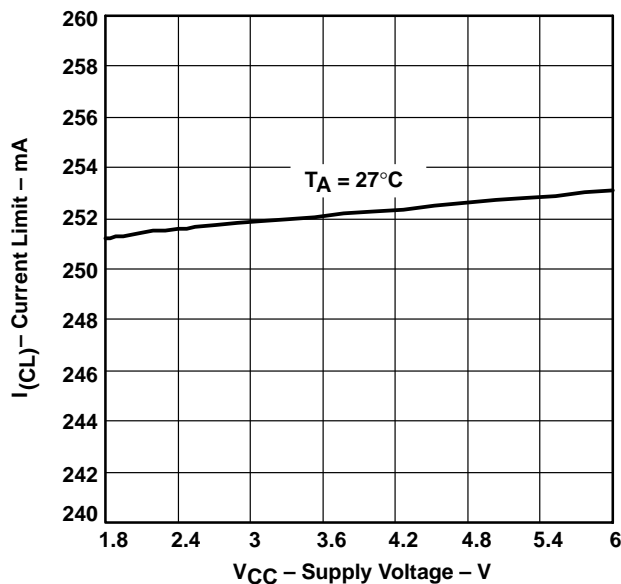

Figure 8

TPS61040  
CURRENT LIMIT  
vs  
SUPPLY VOLTAGE

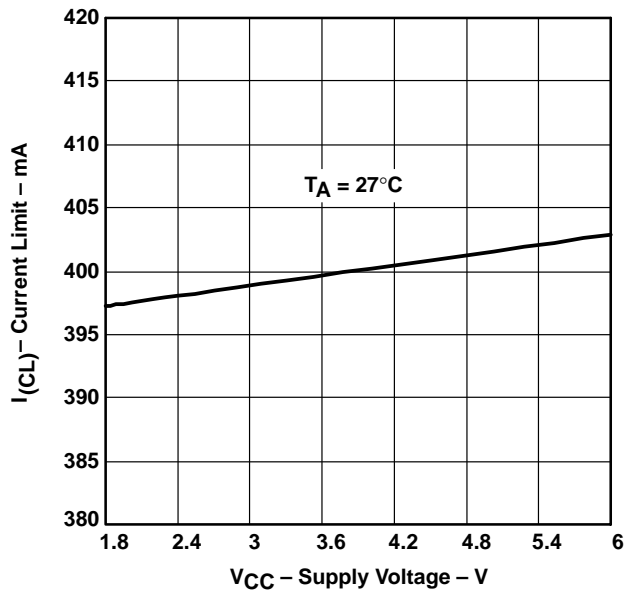

Figure 9

TPS61040/41  
STATIC DRAIN-SOURCE ON-STATE RESISTANCE  
vs  
FREE-AIR TEMPERATURE

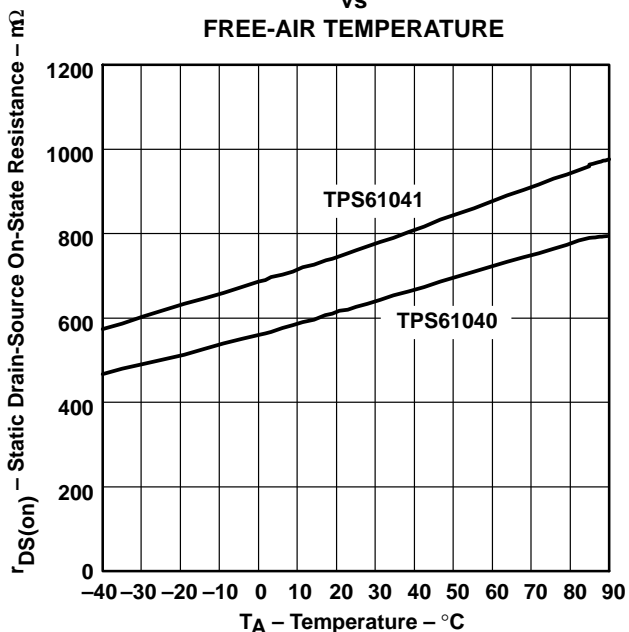

Figure 10



TYPICAL CHARACTERISTICS

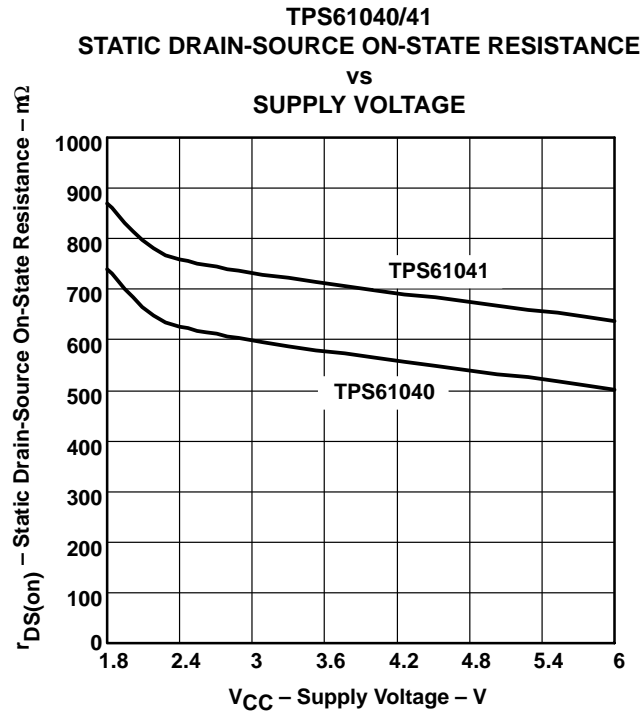

Figure 11

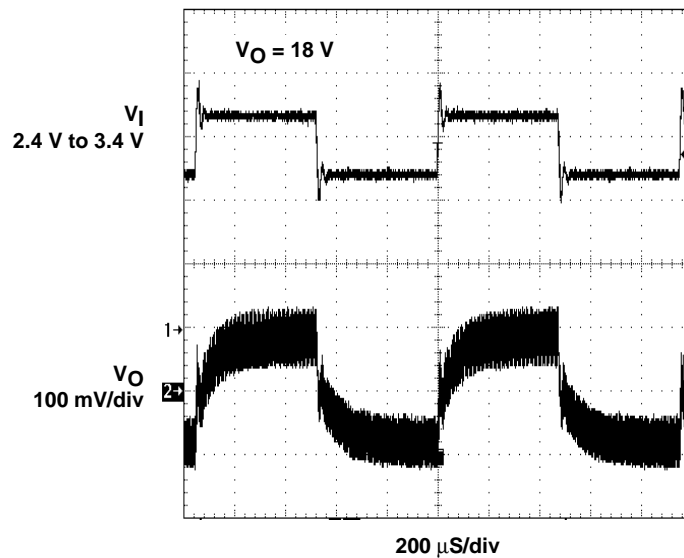

Figure 12. Line Transient Response

TYPICAL CHARACTERISTICS

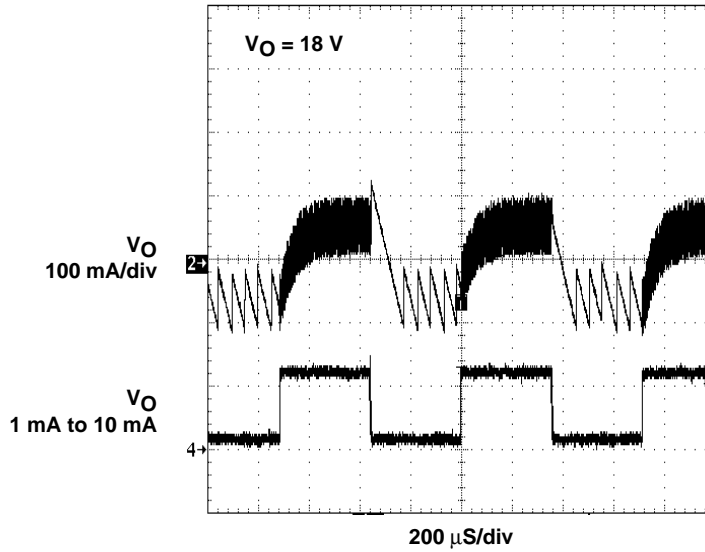

Figure 13. Load Transient Response

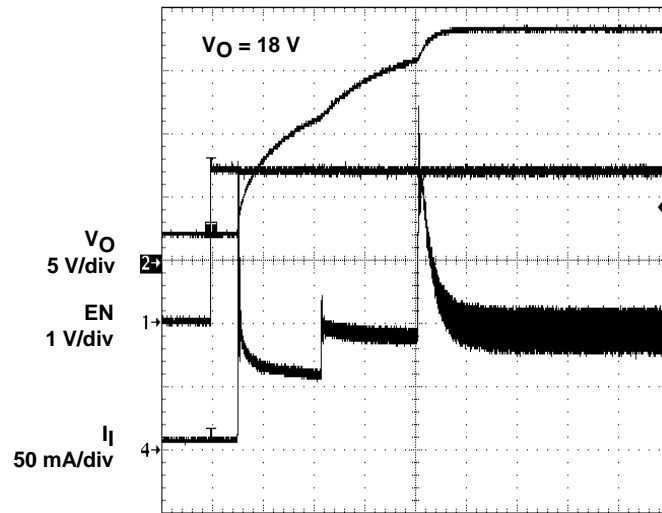

Figure 14. Start-Up Behavior

## APPLICATION INFORMATION

### inductor selection, maximum load current

Since the PFM peak current control scheme is inherently stable, the inductor value does not affect the stability of the regulator. The selection of the inductor together with the nominal load current, input and output voltage of the application determines the switching frequency of the converter. Depending on the application, inductor values between 2.2  $\mu\text{H}$  up to 47  $\mu\text{H}$  are recommended. The maximum inductor value is determined by the maximum on time of the switch, typically 6  $\mu\text{s}$ . The peak current limit of 400 mA/250mA (typically) should be reached within this 6- $\mu\text{s}$  period for proper operation.

The inductor value determines the maximum switching frequency of the converter. Therefore, select the inductor value that ensures the maximum switching frequency at the converter maximum load current is not exceeded. The maximum switching frequency is calculated by the following formula:

$$f_{S_{\max}} = \frac{V_{in_{\min}} \times (V_{out} - V_{in})}{I_P \times L \times V_{out}}$$

Where:

$I_P$  = Peak current as described in the previous *peak current control* section

$L$  = Selected inductor value

$V_{in_{\min}}$  = The highest switching frequency occurs at the minimum input voltage

If the selected inductor value does not exceed the maximum switching frequency of the converter, the next step is to calculate the switching frequency at the nominal load current using the following formula:

$$f_S(I_{load}) = \frac{2 \times I_{load} \times (V_{out} - V_{in} + V_d)}{I_P^2 \times L}$$

Where:

$I_P$  = Peak current as described in the previous *peak current control* section

$L$  = Selected inductor value

$I_{load}$  = Nominal load current

$V_d$  = Rectifier diode forward voltage (typically 0.3V)

A smaller inductor value gives a higher converter switching frequency, but lowers the efficiency.

The inductor value has less effect on the maximum available load current and is only of secondary order. The best way to calculate the maximum available load current under certain operating conditions is to estimate the expected converter efficiency at the maximum load current. This number can be taken out of the efficiency graphs shown in Figures 1, 2, 3, and 4. The maximum load current can then be estimated as follows:

$$I_{load \max} = \eta \frac{I_P^2 \times L \times f_{S_{\max}}}{2 \times V_{out}}$$

Where:

$I_P$  = Peak current as described in the previous *peak current control* section

$L$  = Selected inductor value

$f_{S_{\max}}$  = Maximum switching frequency as calculated previously

$\eta$  = Expected converter efficiency. Typically 70% to 85%

**APPLICATION INFORMATION**

The maximum load current of the converter is the current at the operation point where the converter starts to enter the continuous conduction mode. Usually the converter should always operate in discontinuous conduction mode.

Last, the selected inductor should have a saturation current that meets the maximum peak current of the converter (as calculated in the *peak current control* section). Use the maximum value for  $I_{LIM}$  for this calculation.

Another important inductor parameter is the dc resistance. The lower the dc resistance, the higher the efficiency of the converter. Refer to the Table 1 and the typical applications for the inductor selection.

**Table 1. Recommended Inductor for Typical LCD Bias Supply (see Figure 15)**

DEVICE	INDUCTOR VALUE	COMPONENT SUPPLIER	COMMENTS
TPS61040	10 $\mu$ H	Sumida CR32-100	High efficiency
	10 $\mu$ H	Sumida CDRH3D16-100	High efficiency
	10 $\mu$ H	Murata LQH4C100K04	High efficiency
	4.7 $\mu$ H	Sumida CDRH3D16-4R7	Small solution size
	4.7 $\mu$ H	Murata LQH3C4R7M24	Small solution size
TPS61041	10 $\mu$ H	Murata LQH3C100K24	High efficiency Small solution size

**setting the output voltage**

The output voltage is calculated as:

$$V_{out} = 1.233 \text{ V} \times \left( 1 + \frac{R1}{R2} \right)$$

For battery powered applications a high impedance voltage divider should be used with a typical value for R2 of  $\leq 200 \text{ k}\Omega$  and a maximum value for R1 of  $2.2 \text{ M}\Omega$ . Smaller values might be used to reduce the noise sensitivity of the feedback pin.

A feedforward capacitor across the upper feedback resistor R1 is required to provide sufficient overdrive for the error comparator. Without a feedforward capacitor, or one whose value is too small, the TPS61040/41 shows *double pulses* or a pulse burst instead of single pulses at the switch node (SW), causing higher output voltage ripple. If this higher output voltage ripple is acceptable, the feedforward capacitor can be left out.

The lower the switching frequency of the converter, the larger the feedforward capacitor value required. A good starting point is to use a 10 pF feedforward capacitor. As a first estimation, the required value for the feedforward capacitor at the operation point can also be calculated using the following formula:

$$C_{FF} = \frac{1}{2 \times \pi \times \frac{fS}{20} \times R1}$$

Where:

R1 = Upper resistor of voltage divider

fS = Switching frequency of the converter at the nominal load current (See previous section for calculating the switching frequency)

C<sub>FF</sub>= Choose a value that comes closest to the result of the calculation

## APPLICATION INFORMATION

The larger the feedforward capacitor the worse the line regulation of the device. Therefore, when concern for line regulation is paramount, the selected feedforward capacitor should be as small as possible. See the next section for more information about line and load regulation.

### line and load regulation

The line regulation of the TPS61040/41 depends on the voltage ripple on the feedback pin. Usually a 50 mV peak-to-peak voltage ripple on the feedback pin FB gives good results.

Some applications require a very tight line regulation and can only allow a small change in output voltage over a certain input voltage range. If no feedforward capacitor  $C_{FF}$  is used across the upper resistor of the voltage feedback divider, the device has the best line regulation. Without the feedforward capacitor the output voltage ripple is higher because the TPS61040/41 shows output voltage bursts instead of single pulses on the switch pin (SW), increasing the output voltage ripple. Increasing the output capacitor value reduces the output voltage ripple.

If a larger output capacitor value is not an option, a feedforward capacitor  $C_{FF}$  can be used as described in the previous section. The use of a feedforward capacitor increases the amount of voltage ripple present on the feedback pin (FB). The greater the voltage ripple on the feedback pin ( $\geq 50$  mV), the worse the line regulation. There are two ways to improve the line regulation further:

1. Use a smaller inductor value to increase the switching frequency which will lower the output voltage ripple, as well as the voltage ripple on the feedback pin.
2. Add a small capacitor from the feedback pin (FB) to ground to reduce the voltage ripple on the feedback pin down to 50 mV again. As a starting point, the same capacitor value as selected for the feedforward capacitor  $C_{FF}$  can be used.

### output capacitor selection

For best output voltage filtering, a low ESR output capacitor is recommended. Ceramic capacitors have a low ESR value but tantalum capacitors can be used as well, depending on the application.

Assuming the converter does not show double pulses or pulse bursts on the switch node (SW), the output voltage ripple can be calculated as:

$$\Delta V_{out} = \frac{I_{out}}{C_{out}} \times \left( \frac{1}{fS(I_{out})} - \frac{I_P \times L}{V_{out} + V_d - V_{in}} \right) + I_P \times ESR$$

Where:

$I_P$  = Peak current as described in the previous *peak current control* section

$L$  = Selected inductor value

$I_{out}$  = Nominal load current

$fS(I_{out})$  = Switching frequency at the nominal load current as calculated previously

$V_d$  = Rectifier diode forward voltage (typically 0.3V)

$C_{out}$  = Selected output capacitor

ESR = Output capacitor ESR value

Refer to Table 2 and *typical applications* section for choosing the output capacitor.

**APPLICATION INFORMATION**

**Table 2. Recommended Input and Output Capacitors**

DEVICE	CAPACITOR	VOLTAGE RATING	COMPONENT SUPPLIER	COMMENTS
TPS61040/41	4.7 $\mu$ F/X5R/0805	6.3 V	Tayo Yuden JMK212BY475MG	C <sub>IN</sub> /C <sub>OUT</sub>
	10 $\mu$ F/X5R/0805	6.3 V	Tayo Yuden JMK212BJ106MG	C <sub>IN</sub> /C <sub>OUT</sub>
	1.0 $\mu$ F/X7R/1206	25 V	Tayo Yuden TMK316BJ105KL	C <sub>OUT</sub>
	1.0 $\mu$ F/X5R/1206	35 V	Tayo Yuden GMK316BJ105KL	C <sub>OUT</sub>
	4.7 $\mu$ F/X5R/1210	25 V	Tayo Yuden TMK325BJ475MG	C <sub>OUT</sub>

**input capacitor selection**

For good input voltage filtering, low ESR ceramic capacitors are recommended. A 4.7  $\mu$ F ceramic input capacitor is sufficient for most of the applications. For better input voltage filtering this value can be increased. Refer to Table 2 and typical applications for input capacitor recommendations.

**diode selection**

To achieve high efficiency a Schottky diode should be used. The current rating of the diode should meet the peak current rating of the converter as it is calculated in the section peak current control. Use the maximum value for I<sub>LIM</sub> for this calculation. Refer to Table 3 and the typical applications for the selection of the Schottky diode.

**Table 3. Recommended Schottky Diode for Typical LCD Bias Supply (see Figure 15)**

DEVICE	REVERSE VOLTAGE	COMPONENT SUPPLIER	COMMENTS
TPS61040/41	30 V	ON Semiconductor MBR0530	
	20 V	ON Semiconductor MBR0520	
	20 V	ON Semiconductor MBRM120L	High efficiency
	30 V	Toshiba CRS02	

**layout considerations**

Typical for all switching power supplies, the layout is an important step in the design; especially at high peak currents and switching frequencies. If the layout is not carefully done, the regulator might show noise problems and duty cycle jitter.

The input capacitor should be placed as close as possible to the input pin for good input voltage filtering. The inductor and diode should be placed as close as possible to the switch pin to minimize the noise coupling into other circuits. Since the feedback pin and network is a high impedance circuit the feedback network should be routed away from the inductor. The feedback pin and feedback network should be shielded with a ground plane or trace to minimize noise coupling into this circuit.

Wide traces should be used for connections in bold as shown in Figure 15. A star ground connection or ground plane minimizes ground shifts and noise.

APPLICATION INFORMATION

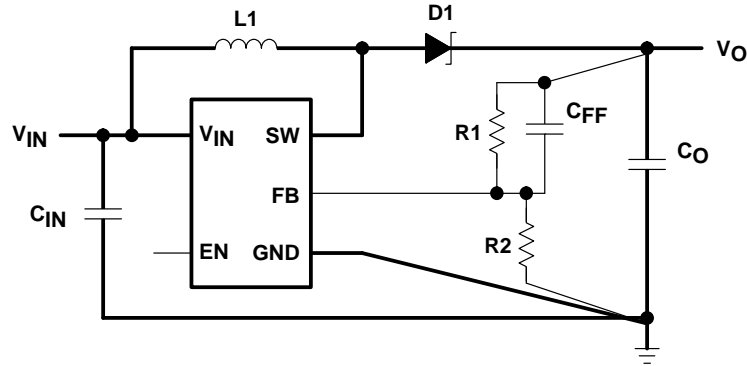

Figure 15. Layout Diagram

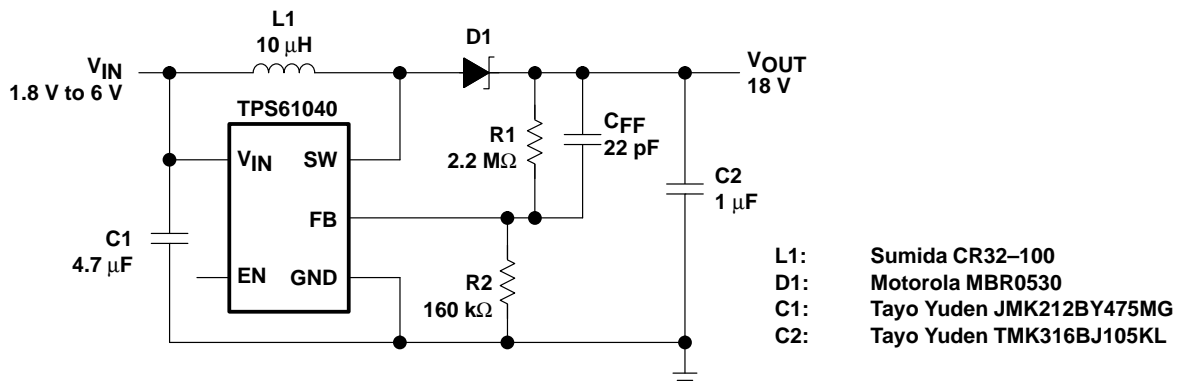

Figure 16. LCD Bias Supply

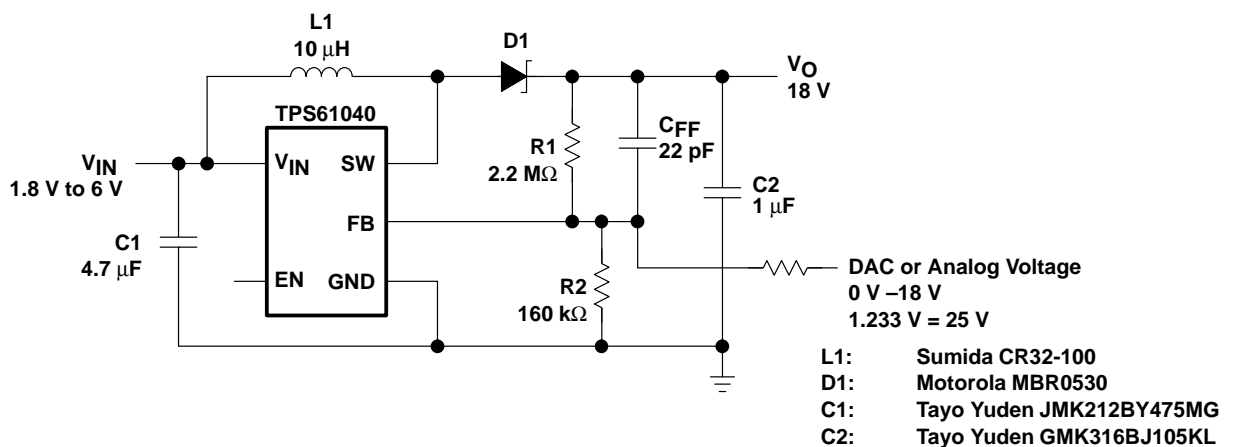

Figure 17. LCD Bias Supply With Adjustable Output Voltage

# TPS61040 TPS61041

SLVS413 – FEBRUARY 2002

## APPLICATION INFORMATION

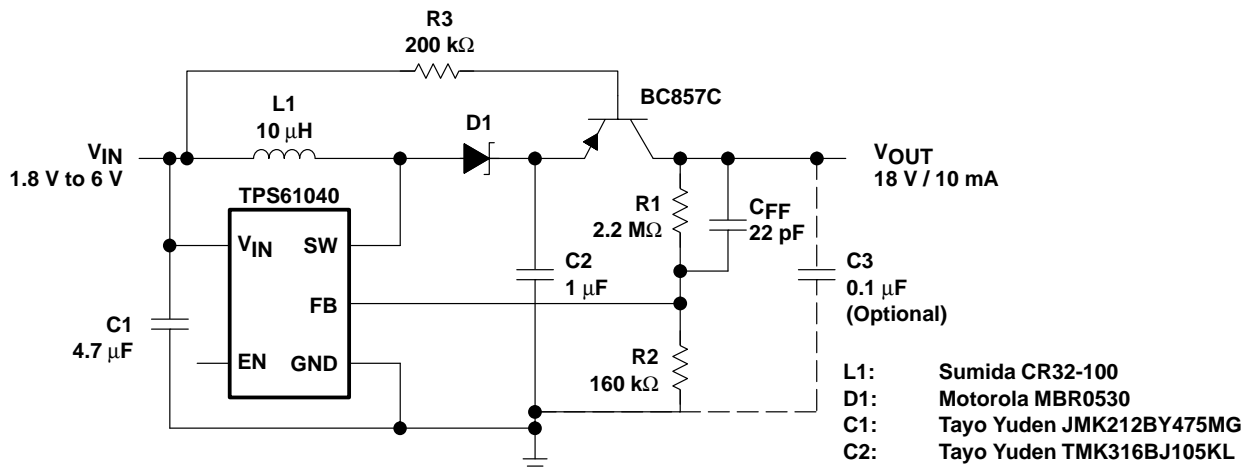

Figure 18. LCD Bias Supply With Load Disconnect

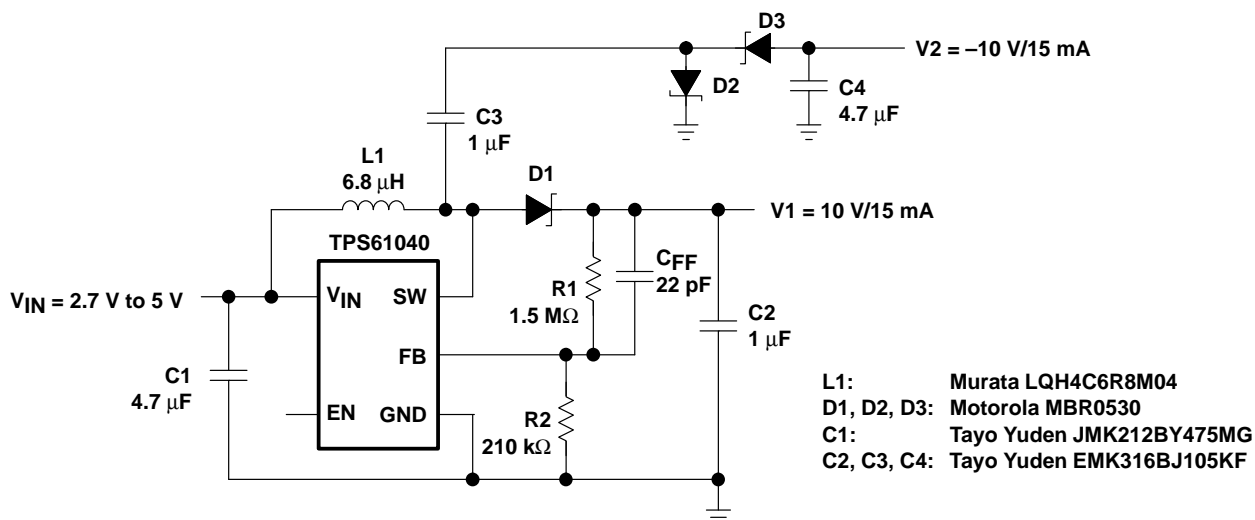

Figure 19. Positive and Negative Output LCD Bias Supply



APPLICATION INFORMATION

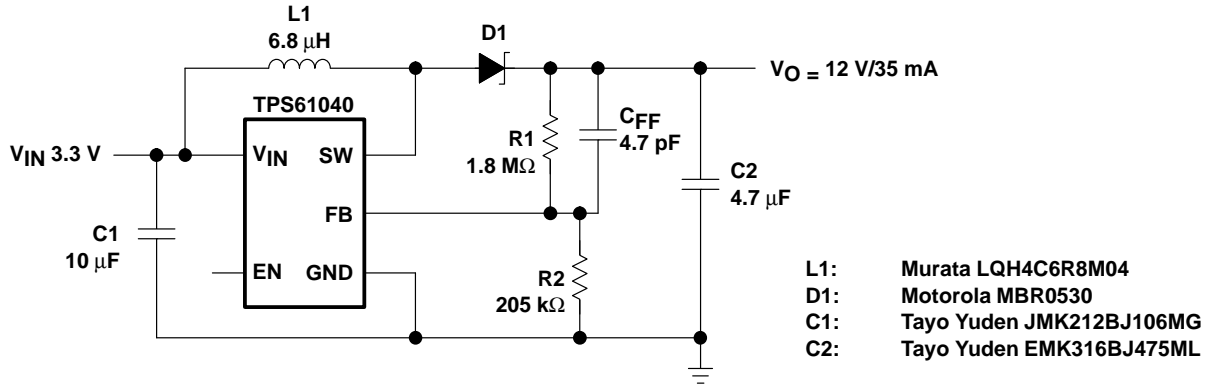

Figure 20. Standard 3.3-V to 12-V Supply

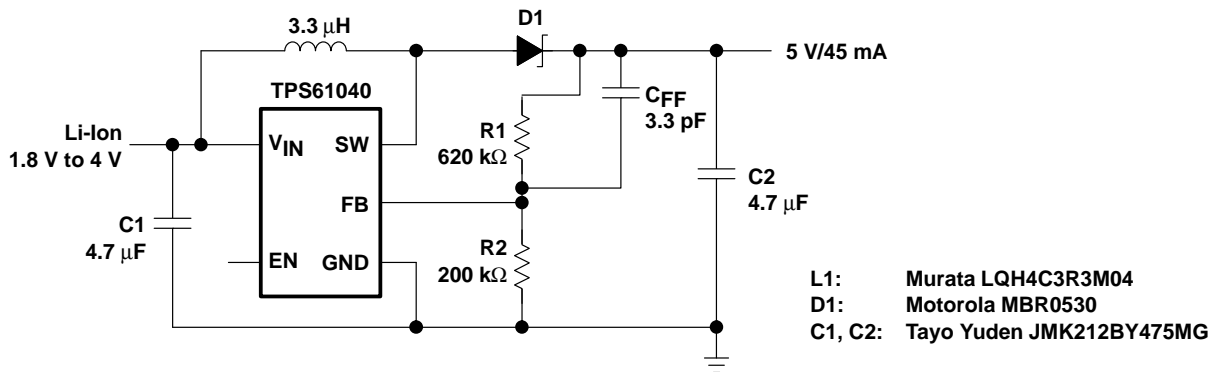

Figure 21. Dual Battery Cell to 5V/50mA Conversion Efficiency  $\approx$  84% at  $V_{in} = 2.4$  V to  $V_o = 5$  V/45 mA

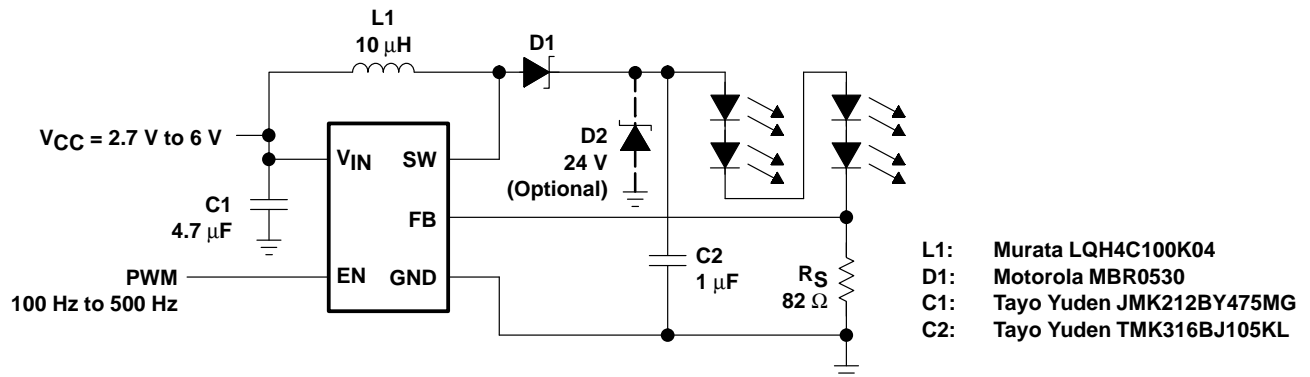
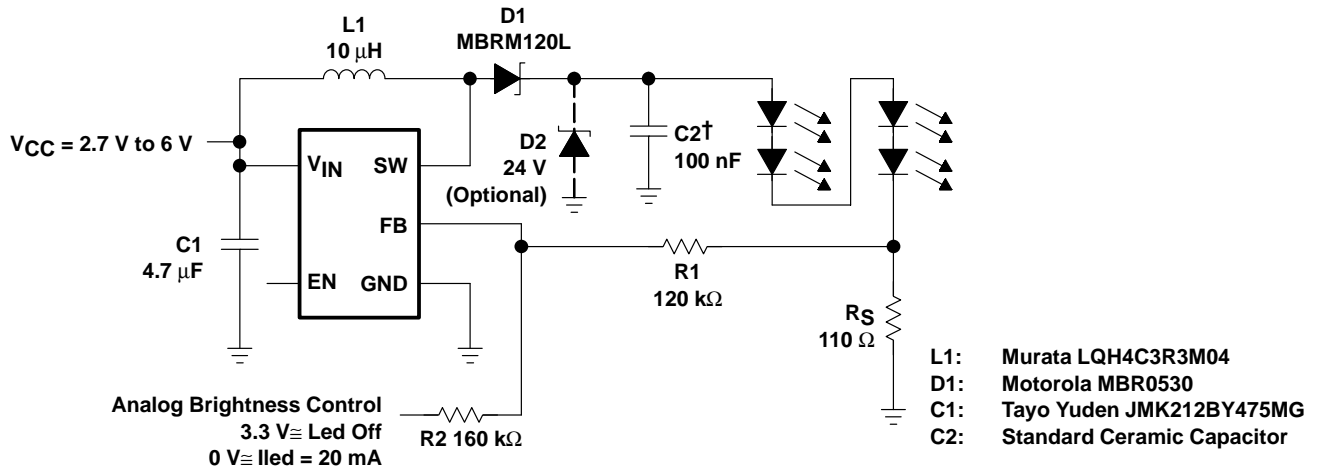

Figure 22. White LED Supply With Adjustable Brightness Control Using a PWM Signal on the Enable Pin  
Efficiency  $\approx$  86% at  $V_{in} = 3$  V,  $I_{LED} = 15$  mA

**TPS61040**  
**TPS61041**

SLVS413 – FEBRUARY 2002



† A smaller output capacitor value for C2 will cause a larger LED ripple

**Figure 23. White LED Supply With Adjustable Brightness Control Using an Analog Signal on the Feedback Pin**

MECHANICAL DATA

DBV (R-PDSO-G5) PLASTIC SMALL-OUTLINE

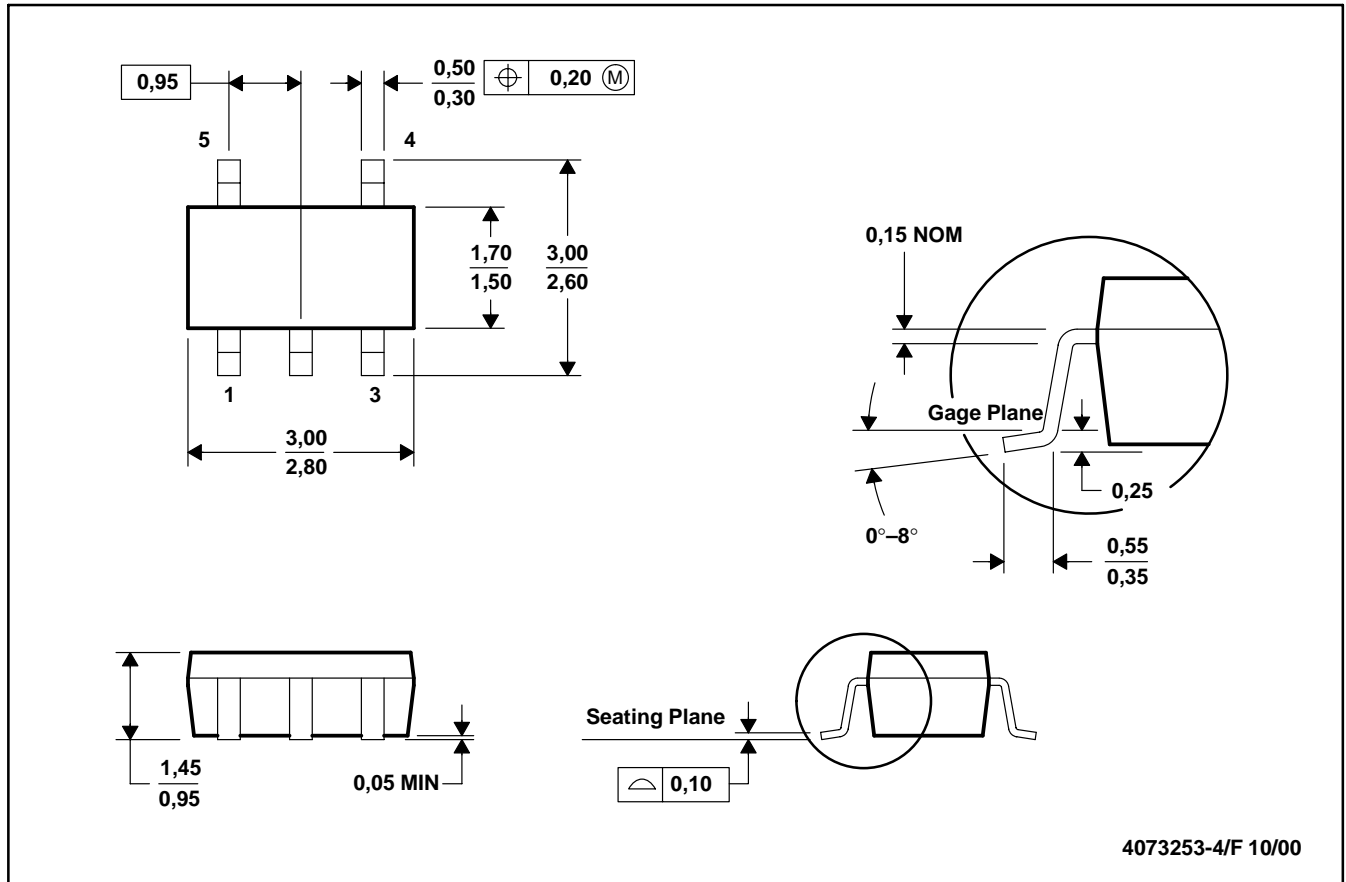

- NOTES: A. All linear dimensions are in millimeters.  
 B. This drawing is subject to change without notice.  
 C. Body dimensions do not include mold flash or protrusion.  
 D. Falls within JEDEC MO-178.

## **IMPORTANT NOTICE**

Texas Instruments Incorporated and its subsidiaries (TI) reserve the right to make corrections, modifications, enhancements, improvements, and other changes to its products and services at any time and to discontinue any product or service without notice. Customers should obtain the latest relevant information before placing orders and should verify that such information is current and complete. All products are sold subject to TI's terms and conditions of sale supplied at the time of order acknowledgment.

TI warrants performance of its hardware products to the specifications applicable at the time of sale in accordance with TI's standard warranty. Testing and other quality control techniques are used to the extent TI deems necessary to support this warranty. Except where mandated by government requirements, testing of all parameters of each product is not necessarily performed.

TI assumes no liability for applications assistance or customer product design. Customers are responsible for their products and applications using TI components. To minimize the risks associated with customer products and applications, customers should provide adequate design and operating safeguards.

TI does not warrant or represent that any license, either express or implied, is granted under any TI patent right, copyright, mask work right, or other TI intellectual property right relating to any combination, machine, or process in which TI products or services are used. Information published by TI regarding third-party products or services does not constitute a license from TI to use such products or services or a warranty or endorsement thereof. Use of such information may require a license from a third party under the patents or other intellectual property of the third party, or a license from TI under the patents or other intellectual property of TI.

Reproduction of information in TI data books or data sheets is permissible only if reproduction is without alteration and is accompanied by all associated warranties, conditions, limitations, and notices. Reproduction of this information with alteration is an unfair and deceptive business practice. TI is not responsible or liable for such altered documentation.

Resale of TI products or services with statements different from or beyond the parameters stated by TI for that product or service voids all express and any implied warranties for the associated TI product or service and is an unfair and deceptive business practice. TI is not responsible or liable for any such statements.

### **Mailing Address:**

Texas Instruments  
Post Office Box 655303  
Dallas, Texas 75265