



晶采光電科技股份有限公司
AMPIRE CO., LTD.

SPECIFICATIONS FOR LCD MODULE

CUSTOMER	
CUSTOMER PART NO.	
AMPIRE PART NO.	AM-800600P5TMQW-A0H
APPROVED BY	
DATE	

Approved For Specifications

Approved For Specifications & Sample

AMPIRE CO., LTD.

**4F., No.116, Sec. 1, Xintai 5th Rd., Xizhi Dist., New Taipei City221,
Taiwan (R.O.C.)**

新北市汐止區新台五路一段 116 號 4 樓(東方科學園區 A 棟)

TEL:886-2-26967269 , FAX:886-2-26967196 or 26967270

APPROVED BY	CHECKED BY	ORGANIZED BY

RECORD OF REVISION

Revision Date	Page	Contents	Editor
2013/07/23	--	New Release	Rober

1. Features

8 inch Amorphous-TFT-LCD (Thin Film Transistor Liquid Crystal Display) module. This module is composed of a 8" TFT-LCD panel, LED backlight and power circuit unit.

- (1) Construction: 8" a-Si TFT active matrix, White LED Backlight and power circuit board.
- (2) Resolution (pixel): 800(R.G.B) X600
- (3) Number of the Colors : 262K colors (R , G , B 6 bit digital each)
- (4) LCD type : Transmissive , normally White
- (5) Interface: 20 Pin (LVDS interface)
- (6) Power Supply Voltage: 3.3V for logic voltage, 5.0V for LED driver power voltage.
- (6) Viewing Direction: 6 O'clock (Gray Inversion)

2. PHYSICAL SPECIFICATIONS

Item	Specifications	unit
LCD size	8 inch (Diagonal)	
Resolution	800 x 3(RGB) x 600	dot
Dot pitch	0.0675(W) x 0.2025(H)	mm
Active area	162.0(W) x 121.5(H)	mm
Module size	183.0(W) x 141.0(H) x10.35(D)	mm
Surface treatment	Anti-Glare	
Color arrangement	RGB-stripe	
interface	Digital	

3. ABSOLUTE MAX. RATINGS

Item	Symbol	Values		UNIT	Note
		Min.	Max.		
Power voltage	VCC	-0.5	5	V	
	VLED	-0.5	6.0		
Input signal voltage	Vi	-0.3	VCC+0.3	V	Note 1
Operation temperature	TOP	-20	70	°C	
Storage temperature	TST	-30	80	°C	

Note 1: The product is subject to be damaged permanently if stresses beyond those absolute maximum ratings listed above.

4. ELECTRICAL CHARACTERISTICS

4-1 TFT LCD Module

		MIN	NOM	MAX	UNIT
V_{CC}	Supply voltage	3	3.3	3.6	V
V_{IH}	High-level input voltage (SHTDN)	2			V
V_{IL}	Low-level input voltage (SHTDN)			0.8	V
$ V_{ID} $	Magnitude differential input voltage	0.1		0.6	V
V_{IC}	Common-mode input voltage	$\frac{ V_{ID} }{2}$		$2.4 - \frac{ V_{ID} }{2}$	V

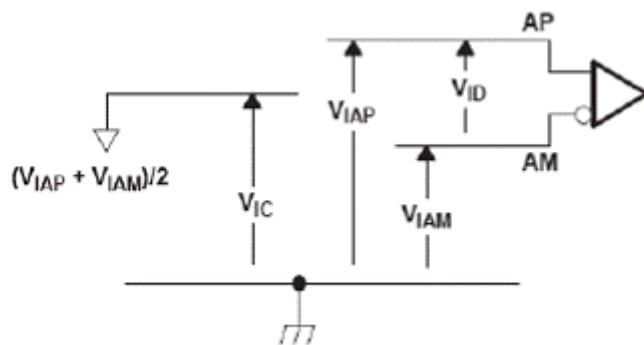

4-2 Backlight Driving Conditions

Item	Symbol	Values			Unit	Note
		Min.	Typ.	Max.		
LED Driver voltage	VLED	3.3	5	9	V	
ADJ Input Voltage	V _{ADJ}	-	3.3	5	V	duty=100% Note(3)
LED voltage	VAK	--	9.9	15	V	I _{LED} =160mA Ta=25°C
LED current	I _L	--	160	--	mA	Ta=25°C
		--	150	--	mA	Ta=60°C
LED Life Time	-	--	10K	--	Hour	Note (2)

Note (1) The constant current source is needed for white LED back-light driving. When LCM is operated over 60°C ambient temperature, the I_L of the LED back-light should be adjusted to 150mA max

Note (2) Brightness to be decreased to 50% of the initial value.

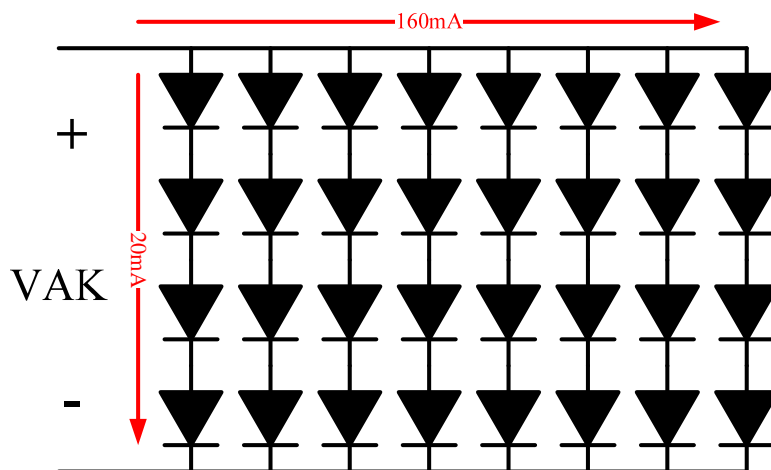

When LCM is operated over 40°C ambient temperature, the I_{LED} should be follow :

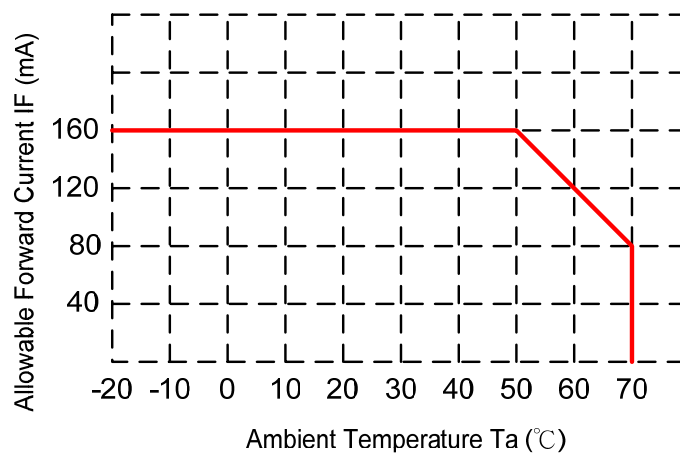

4-3 Power Sequence

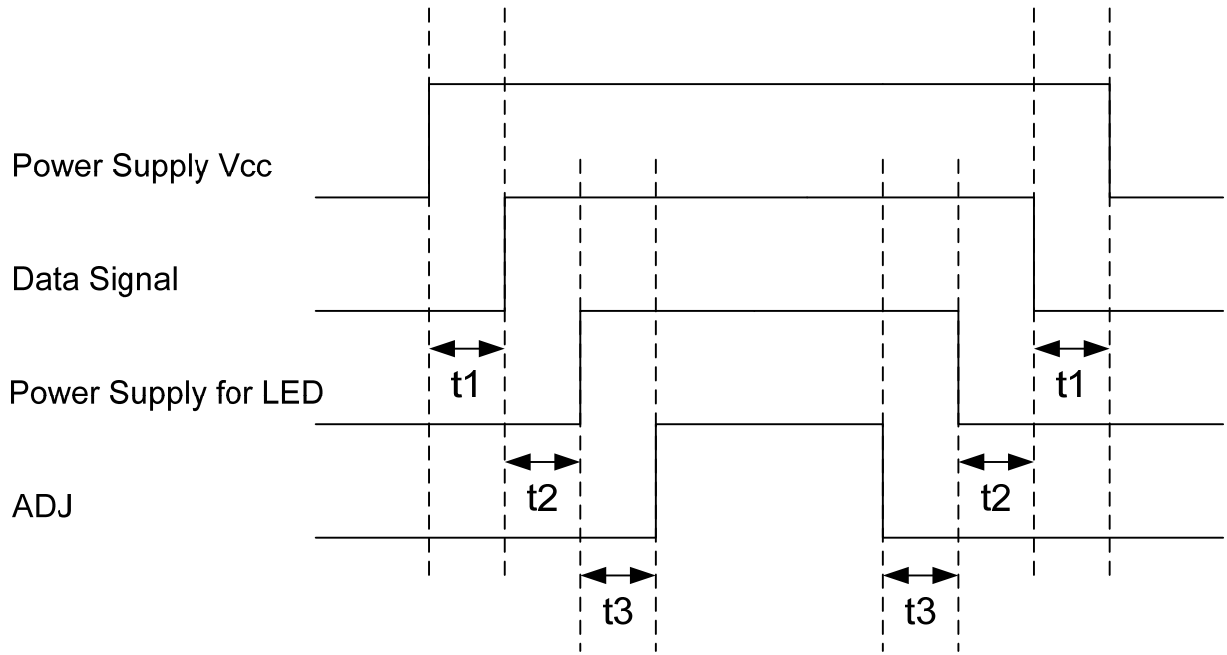

$t1 > 50 \text{ mSec}$
 $t2 \geq 200 \text{ mSec}$
 $t3 \geq 50 \text{ mSec}$

5. Optical Specifications

Item	Symbol	Condition	Values			Unit	Note
			Min.	Typ.	Max.		
Viewing angle (CR \geq 10)	θ L	$\Phi = 180^\circ$ (9 o'clock)	60	70	--	degree	Note1
	θ R	$\Phi = 0^\circ$ (3 o'clock)	60	70	--		
	θ T	$\Phi = 90^\circ$ (12 o'clock)	40	50	--		
	θ B	$\Phi = 270^\circ$ (6 o'clock)	60	70	--		
Response time	TON	Normal $\theta = \Phi = 0^\circ$	--	25	30	msec	Note3
	TOFF		--	25	30	msec	
Contrast ratio	CR		400	500	--	--	Note4
Color chromaticity	Rx		0.553	0.603	0.653	--	Note5
	Ry		0.275	0.325	0.375		
	Gx		0.254	0.304	0.354		
	Gy		0.502	0.552	0.602		
	Bx		0.088	0.138	0.188		
	By		0.086	0.136	0.186		
	Wx		0.264	0.314	0.364		
	Wy	0.288	0.338	0.388	--		
Uniformity	U	70	80	-	%	Note6	
Luminance	L	--	500	--	cd/m ²	Note7	

Test Conditions:

1. The ambient temperature is 25°C.
2. The test systems refer to Note 1 and Note 2.

Note 1: Definition of optical measurement system.

The optical characteristics should be measured in dark room. After 5 Minutes operation, the optical properties are measured at the center point of the LCD screen. All input terminals LCD panel must be ground when measuring the center area of the panel.

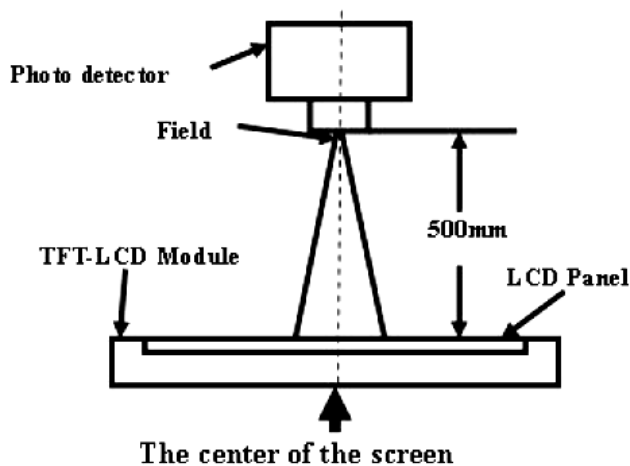

Item	Photo detector	Field
Contrast Ratio	BM-5A	1°
Luminance		
Lum Uniformity		
Chromaticity	SR-3A	
Response Time	TRD100	-

Note 2: Definition of viewing angle range and measurement system.

Viewing angle is measured at the center point of the LCD by CONOSCOPE (ergo-80).

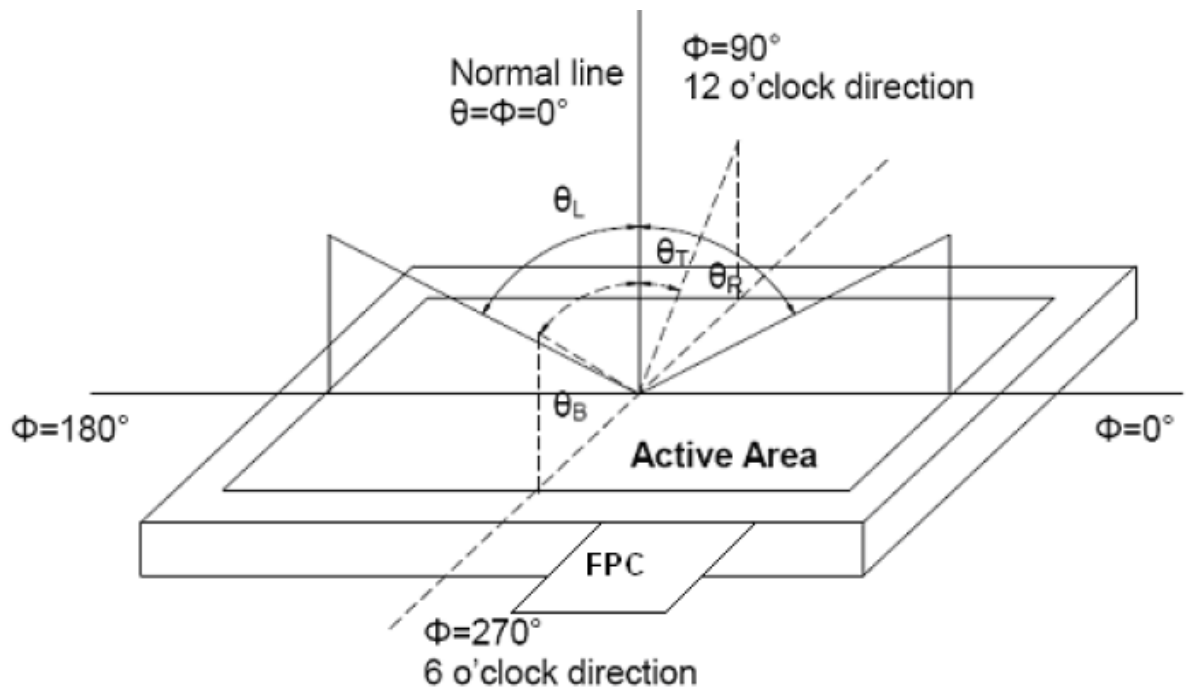

Note 3: Definition of contrast ratio.

$$\text{Contrast ratio (CR)} = \frac{\text{Luminance measured when LCD is on the "White" state}}{\text{Luminance measured when LCD is on the "Black" state}}$$

“White state “: The state is that the LCD should drive by V_{white} .

“Black state”: The state is that the LCD should drive by V_{black} .

V_{white} : To be determined V_{black} : To be determined.

Note 4: Definition of Response time.

The response time is defined as the LCD optical switching time interval between “White” state and “Black” state. Rise time (T_{ON}) is the time between photo detector output intensity changed

from 90% to 10%. And fall time (T_{OFF}) is the time between photo detector output intensity changed from 10% to 90%.

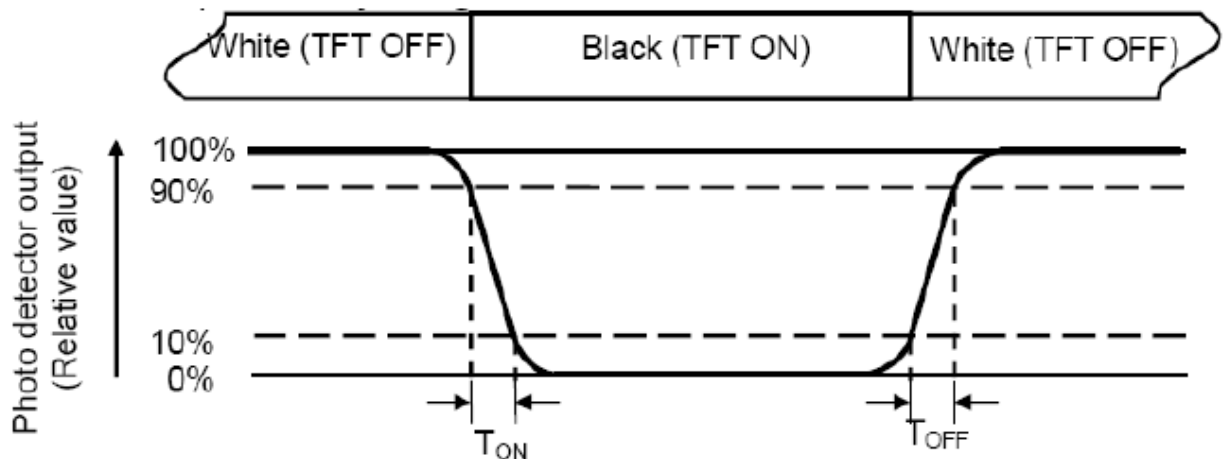

Note 5: Definition of color chromaticity (CIE1931) Color coordinates measured at center point of LCD.

Note 6: Definition of Luminance Uniformity.

Active area is divided into 9 measuring areas (Refer Fig. 2). Every measuring point is placed at the center of each measuring area.

Luminance Uniformity (U) = L_{min} / L_{max}

L ----Active area length, W ---- Active area width

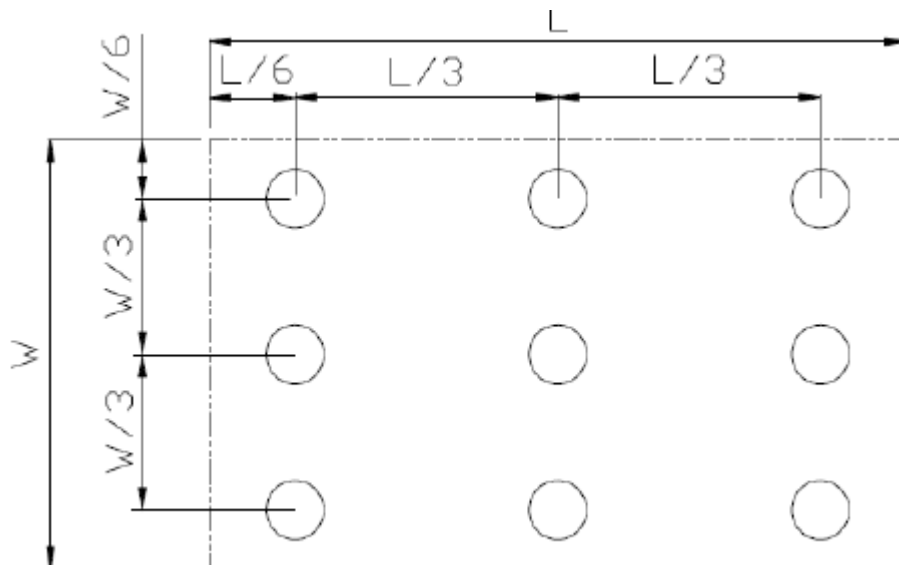

L_{max} : The measured Maximum luminance of all measurement position.

L_{min} : The measured Minimum luminance of all measurement position.

Note 7: Definition of Luminance.

Measure the luminance of white state at center point.

6. INTERFACE

TFT LCD Panel Driving Section

Pin No.	Symbol	Description	Note
1	VDD	POWER SUPPLY:3.3V	
2	VDD	POWER SUPPLY:3.3V	
3	GND	Power Ground	
4	GND	Power Ground	
5	IN0-	Transmission Data	
6	IN0+	Transmission Data	
7	GND	Power Ground	
8	IN1-	Transmission Data	
9	IN1+	Transmission Data	
10	GND	Power Ground	
11	IN2-	Transmission Data	
12	IN2+	Transmission Data	
13	GND	Power Ground	
14	CLK-	Sampling Clock	
15	CLK+	Sampling Clock	
16	GND	Power Ground	
17	VLED	POWER SUPPLY for Backlight : 5V	
18	VLED	POWER SUPPLY for Backlight : 5V	
19	GND	Power Ground	
20	ADJ	Adjust the LED brightness	

NOTE :

(1) Pin19: ADJ is PWM signal input. It is for brightness control.

ITEM	SYMBOL	MIN	TYP	MAX	UNIT
ADJ signal frequency	f_{PWM}	5K	20K	100K	Hz
ADJ signal logic level High	V _{IH}	2.4V	--	V _{LED} (5.0V)	V
ADJ signal logic level Low	V _{IL}	0	--	0.8	V

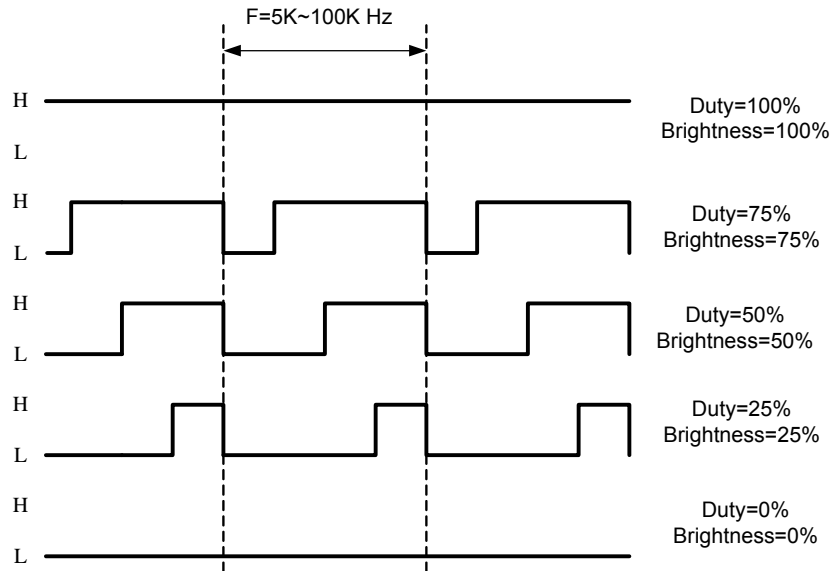

7. INTERFACE TIMING (The information as below is to be defined.)

7-1 LVDS SIGNAL :

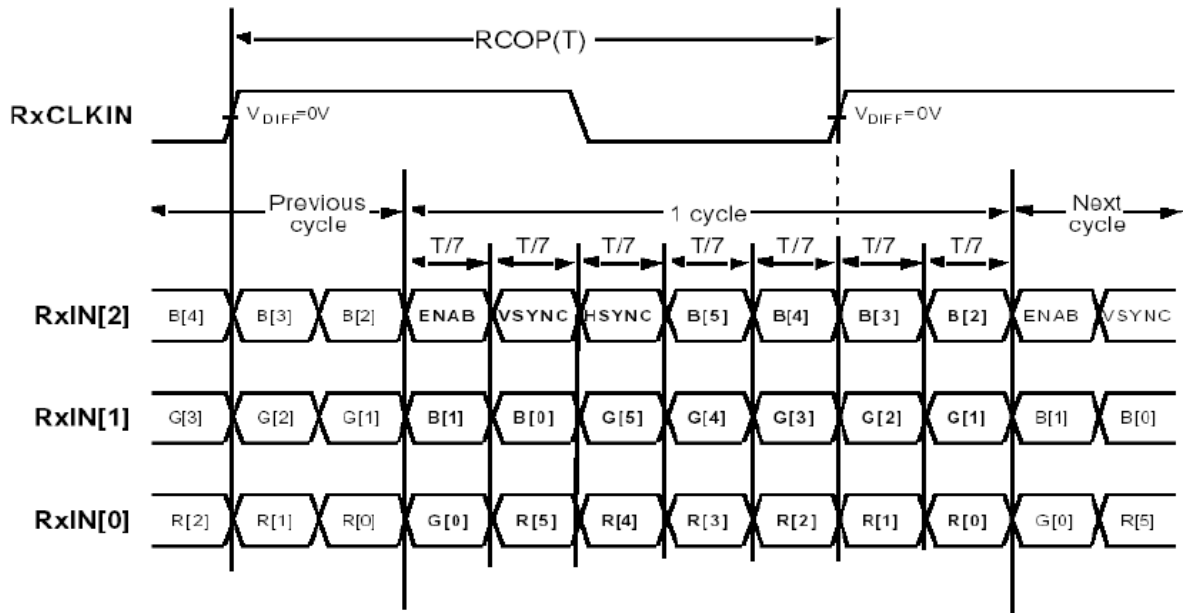

Note : R/G/B[5]s are MSBs and R/G/B[0]s are LSBs

7-2 LVDS AC Timing Diagram :

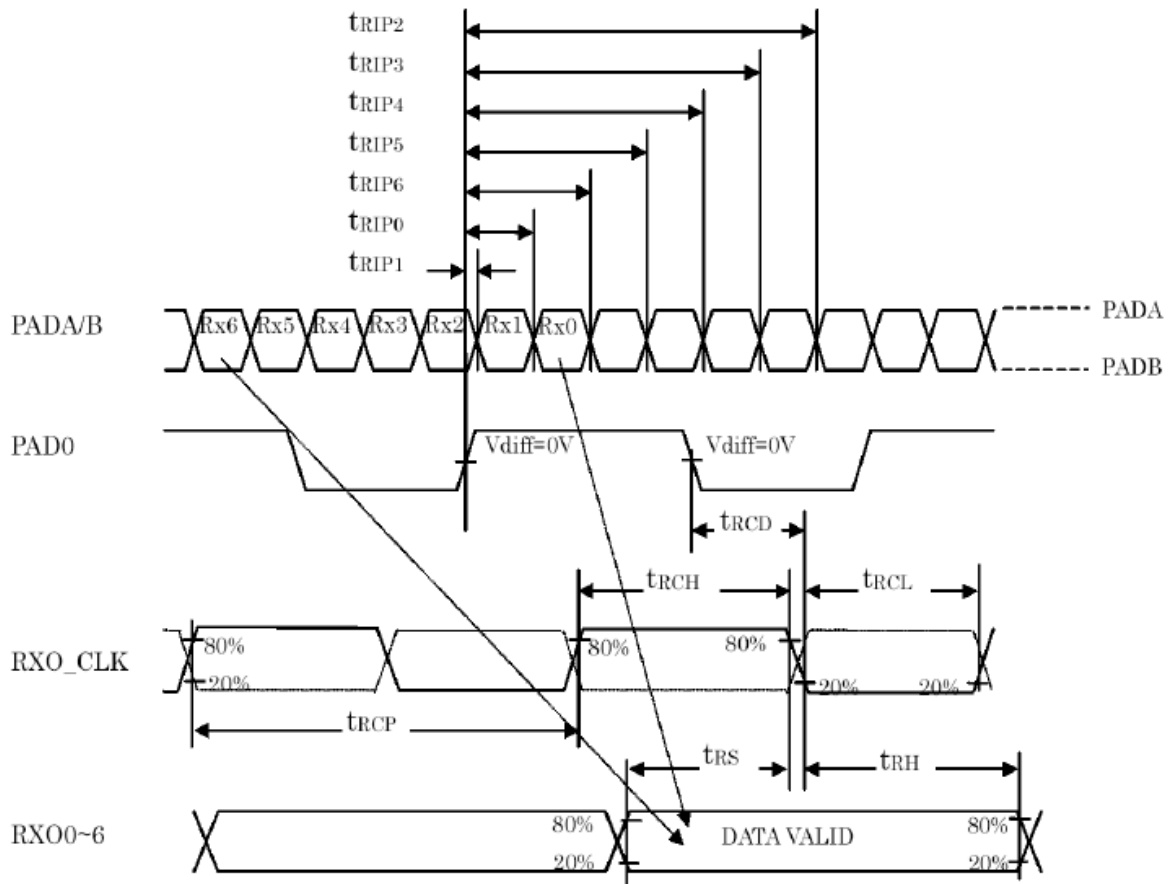

7-3 Phase Lock Loop Set Time :

(Case1)

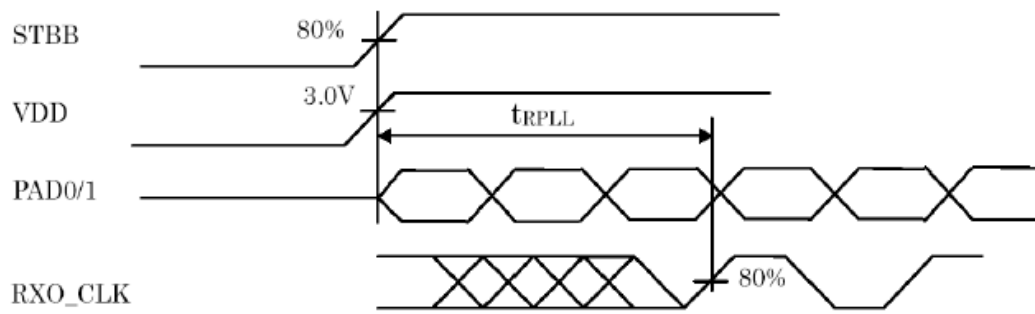

(Case2)

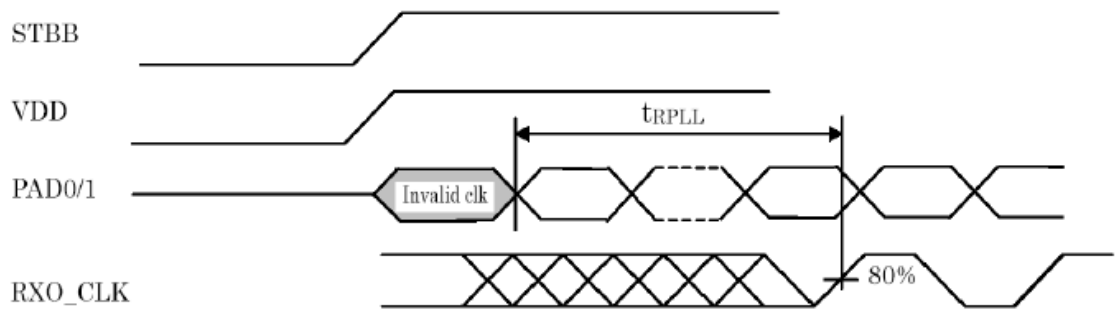

7-4 Recommended Input Timing of LVDS transmitter :

Recommended Timing Setting Of TCON

TCON (Embedded In Source IC) Input Timing (DCLK, HSD, VSD, DE)

VCC=3.3V, AVDD=12.5V, AGND=GND=0V, Ta=25°C

Parameter	Symbol	Min	Typ.	Max	Unit	Remark
DCLK	Fclk	-	40	50	MHz	-
	tclk	20	25	-	ns	-
HSD	th	-	1000	-	tclk	-
	thd	-	800	-	tclk	-
	thpw	1	48	-	tclk	-
	thb	-	88	-	tclk	-
	thfp	-	112	-	tclk	-
VSD	tv	-	660	-	th	-
	tvd	-	600	-	th	-
	tvpw	-	3	-	th	-
	tvb	-	39	-	th	-
	tvfp	-	21	-	th	-

Note: DE timing refer to HSD, VSD input timing.

Vertical input timing Diagram:

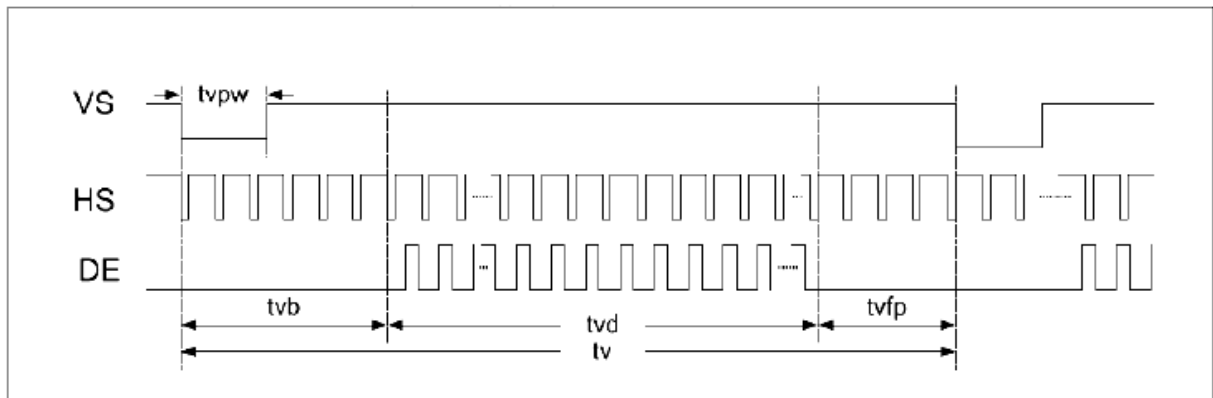

Horizontal input timing Diagram:

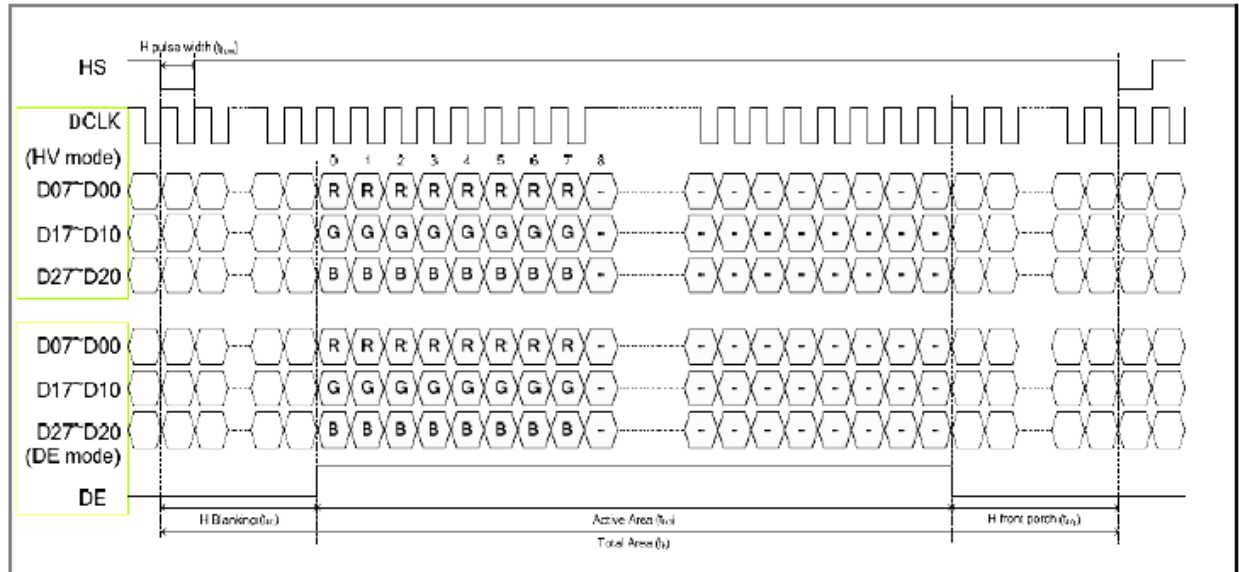

9. Reliability Test Items

Test Item	Test Conditions	Note
High Temperature Operation	70±3°C , t=240 hrs	
Low Temperature Operation	-20±3°C , t=240 hrs	
High Temperature Storage	80±3°C , t=240 hrs	1,2
Low Temperature Storage	-30±3°C , t=240 hrs	1,2
Storage at High Temperature and Humidity	60°C, 90% RH , 240 hrs	1,2
Thermal Shock Test	-20°C (30min) ~ 70°C (30min) 100 cycles	1,2
Vibration Test (Packing)	Sweep frequency : 10 ~ 55 ~ 10 Hz/1min Amplitude : 0.75mm Test direction : X.Y.Z/3 axis Duration : 30min/each axis	2

Note 1 : Condensation of water is not permitted on the module.

Note 2 : The module should be inspected after 1 hour storage in normal conditions (15-35°C , 45-65%RH).

10. General Precautions

10-1 Safety

Liquid crystal is poisonous. Do not put it your mouth. If liquid crystal touches your skin or clothes, wash it off immediately by using soap and water.

10-2 Handling

1. The LCD panel is plate glass. Do not subject the panel to mechanical shock or to excessive force on its surface.
2. The polarizer attached to the display is easily damaged. Please handle it carefully to avoid scratch or other damages.
3. To avoid contamination on the display surface, do not touch the module surface with bare hands.
4. Keep a space so that the LCD panels do not touch other components.
5. Put cover board such as acrylic board on the surface of LCD panel to protect panel from damages.
6. Transparent electrodes may be disconnected if you use the LCD panel under environmental conditions where the condensation of dew occurs.
7. Do not leave module in direct sunlight to avoid malfunction of the ICs.

10-3 Static Electricity

1. Be sure to ground module before turning on power or operation module.
2. Do not apply voltage which exceeds the absolute maximum rating value.

10-4 Storage

1. Store the module in a dark room where must keep at $+25\pm 10^{\circ}\text{C}$ and 65%RH or less.
2. Do not store the module in surroundings containing organic solvent or corrosive gas.
3. Store the module in an anti-electrostatic container or bag.

10-5 Cleaning

1. Do not wipe the polarizer with dry cloth. It might cause scratch.
2. Only use a soft sloth with IPA to wipe the polarizer, other chemicals might permanent damage to the polarizer.

10-5 Others

1. Do not keep the LCD at the same display pattern continually. The residual image will happen and it will damage the LCD. Please use screen saver.
2. AMIPRE will provide one year warrantee for all products and three months warrantee for all repairing products.

11. OUTLINE DIMENSION

REV	REVISION RECORD	DATE	NAME
0	NEW RELEASE	02-25-11	EMILY
1	TFT-800600-85C-0 Rename to 800600P2-A0	03-07-11	EMILY

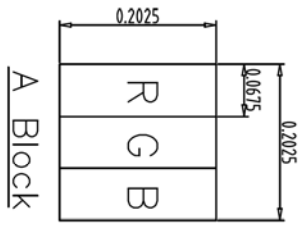

CN4			
1	VDD	11	IN2-
2	VDD	12	IN2+
3	GND	13	GND
4	GND	14	CLK-
5	INO-	15	CLK+
6	INO+	16	GND
7	GND	17	VLED
8	IN1-	18	VLED
9	IN1+	19	GND
10	GND	20	ADJ

Note:

1. Unless indicated, Tolerance "±0.3".
2. UV Glue For OLB Protection.
3. CN1:BHSR-02VS-1
4. CN2:P0.5 SOPin Connector:Hirose "FH12A-50S-0.5H" or Equivalent
5. CN4:P1.0 20Pin Connector:HIROSHI DF19G-20P-1H or Equivalent

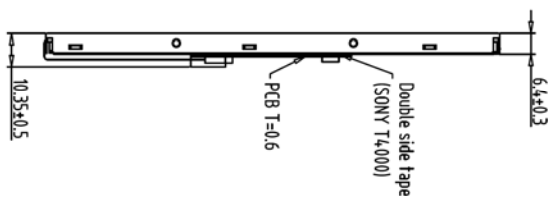
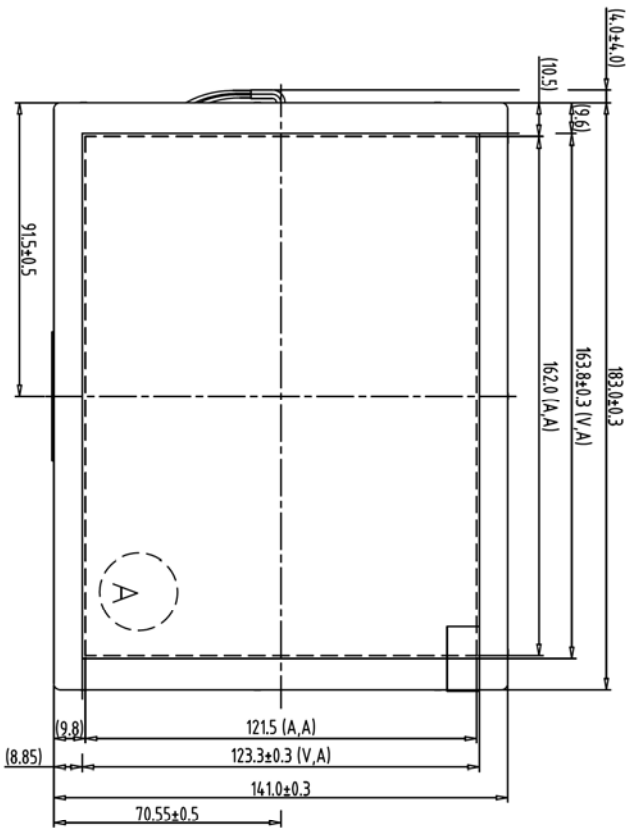

適用機種:

800600P2-A0
800600P2-A1

1	TFT-800600-85C-0	7	TOLERANCE GRADE(%)	A	B	DIM.	MM	DWR.	EMILY	DATE	TITLE
2		8								02-25-11	800600P2-A0
3		9				IP NO.		CHEK.		DATE	(8.0"+LVDS+LED Driver)
4		10				PARTS NO. LCM	800600P2-A0	APPD.		DATE	DWG. NO.
5		11									*110236MA
6		12									SHEET 1 OF 1

MM
晶采光電科技

