

# Thin Film Precision Chip Resistor – AR Series

## Construction

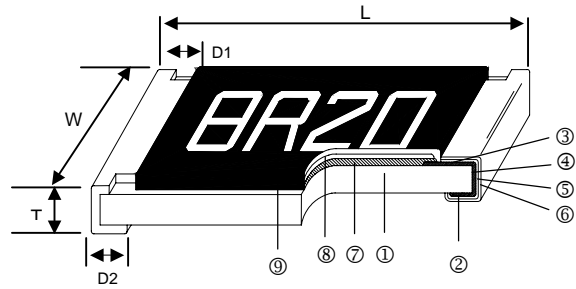

① Alumina Substrate	④ Edge Electrode (NiCr)	⑦ Resistor Layer (NiCr)
② Bottom Electrode (Ag)	⑤ Barrier Layer (Ni)	⑧ Overcoat (Epoxy)
③ Top Electrode (Ag-Pd)	⑥ External Electrode (Sn)	⑨ Marking

## Features

- Advanced thin film technology
- Very tight tolerance down to  $\pm 0.01\%$
- Extremely low TCR down to  $\pm 5\text{PPM}/^\circ\text{C}$
- Wide resistance range 1ohm ~ 3Mega ohm
- Miniature size 0201 available

## Applications

- Medical Equipment
- Testing / Measurement Equipment
- Printer Equipment
- Automatic Equipment Controller
- Converters
- Communication Device, Cell Phone, GPS, PDA

## Dimensions

Unit: mm

Type	Size (Inch)	L	W	T	D1	D2	Weight (g) (1000pcs)
AR01	0201	0.58 $\pm$ 0.05	0.29 $\pm$ 0.05	0.23 $\pm$ 0.05	0.12 $\pm$ 0.05	0.15 $\pm$ 0.05	0.14
AR02	0402	1.00 $\pm$ 0.05	0.50 $\pm$ 0.05	0.30 $\pm$ 0.05	0.20 $\pm$ 0.10	0.20 $\pm$ 0.10	0.54
AR03	0603	1.55 $\pm$ 0.10	0.80 $\pm$ 0.10	0.45 $\pm$ 0.10	0.30 $\pm$ 0.20	0.30 $\pm$ 0.20	1.83
AR05	0805	2.00 $\pm$ 0.15	1.25 $\pm$ 0.15	0.55 $\pm$ 0.10	0.30 $\pm$ 0.20	0.40 $\pm$ 0.25	4.71
AR06	1206	3.05 $\pm$ 0.15	1.55 $\pm$ 0.15	0.55 $\pm$ 0.10	0.42 $\pm$ 0.20	0.35 $\pm$ 0.25	9.02
AR13	1210	3.10 $\pm$ 0.15	2.40 $\pm$ 0.15	0.55 $\pm$ 0.10	0.40 $\pm$ 0.20	0.55 $\pm$ 0.25	10
AR10	2010	4.90 $\pm$ 0.15	2.40 $\pm$ 0.15	0.55 $\pm$ 0.10	0.60 $\pm$ 0.30	0.50 $\pm$ 0.25	23.61
AR12	2512	6.30 $\pm$ 0.15	3.10 $\pm$ 0.15	0.55 $\pm$ 0.10	0.60 $\pm$ 0.30	0.50 $\pm$ 0.25	38.06

## Part Numbering

AR	03	T	T	B	Y	1001	N
Product Type	Dimensions	Resistance Tolerance	Packaging Code	TCR (PPM/ $^\circ\text{C}$ )	Power Rating	Resistance	Marking Code
	01: 0201 02: 0402 03: 0603 05: 0805 06: 1206 13: 1210 10: 2010 12: 2512	T: $\pm 0.01\%$ A: $\pm 0.05\%$ B: $\pm 0.1\%$ C: $\pm 0.25\%$ D: $\pm 0.5\%$ F: $\pm 1\%$	T: Taping Reel B: Bulk	S: $\pm 5$ B: $\pm 10$ N: $\pm 15$ C: $\pm 25$ D: $\pm 50$	: Standard Y: 1/16W X: 1/10W W: 1/8W P: 1/5W V: 1/4W O: 1/3W U: 1/2W T: 1W	0010: 1 $\Omega$ 4R70: 4.7 $\Omega$ 1001: 1K $\Omega$ 1004: 1M $\Omega$	: Standard Marking for E96 / E24 N: No Marking

## Derating Curve

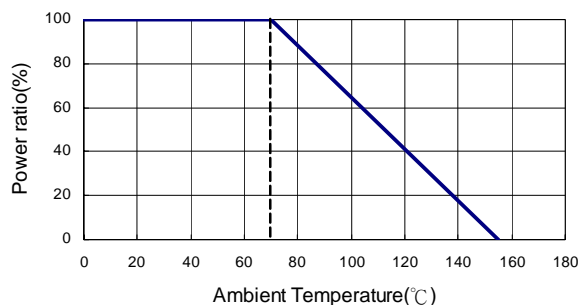

## Standard Electrical Specifications

Item Type	Power Rating at 70°C	Operating Temp. Range	Max. Operating Voltage	Max. Overload Voltage	Resistance Range					TCR (PPM/°C)
					±0.05%	±0.1%	±0.25%	±0.5%	±1%	
AR01 (0201)	1/32W	-55 ~ +155°C	15V	30V	—			49.9Ω - 5KΩ	±25	
								49.9Ω - 33KΩ	±50	
AR02 (0402)	1/16W	-55 ~ +155°C	25V	50V	10Ω - 205KΩ				±25	
					10Ω - 205KΩ	1Ω - 205KΩ	±50			
AR03 (0603)	1/16W	-55 ~ +155°C	50V	100V	4.7Ω - 332KΩ	4.7Ω - 1MΩ	2Ω - 1MΩ	±25 ±50		
AR05 (0805)	1/10W	-55 ~ +155°C	100V	200V	4.7Ω - 511KΩ	4.7Ω - 2MΩ	1Ω - 2MΩ	±25 ±50		
AR06 (1206)	1/8W	-55 ~ +155°C	150V	300V	4.7Ω - 1MΩ	4.7Ω - 2.5MΩ	1Ω - 2.5MΩ	±25 ±50		
AR13 (1210)	1/5W									
AR10 (2010)	1/4W	-55 ~ +155°C	150V	300V	4.7Ω - 1MΩ	4.7Ω - 3MΩ	1Ω - 3MΩ	±25 ±50		
AR12 (2512)	1/2W									

Operating Voltage= $\sqrt{P \cdot R}$  or Max. operating voltage listed above, whichever is lower.

Overload Voltage= $2.5 \cdot \sqrt{P \cdot R}$  or Max. overload voltage listed above, whichever is lower.

■ Lower Resistance: 1~10Ω

## Special Electrical Specifications

Item Type	Power Rating at 70°C	Operating Temp. Range	Max. Operating Voltage	Max. Overload Voltage	Resistance Range			TCR (PPM/°C)
					±0.01%	±0.05%	±0.1%	
AR02 (0402)	1/16W	-55 ~ +155°C	25V	50V	49.9Ω - 5KΩ			±5
					49.9Ω - 12KΩ			±10
					49.9Ω - 12KΩ	49.9Ω - 70KΩ	±15	
AR03 (0603)	1/16W	-55 ~ +155°C	50V	100V	24.9Ω - 15KΩ			±5
					24.9Ω - 100KΩ	4.7Ω - 332KΩ	±10 ±15	
AR05 (0805)	1/10W	-55 ~ +155°C	100V	200V	24.9Ω - 30KΩ			±5
					24.9Ω - 200KΩ	4.7Ω - 511KΩ	±10 ±15	
AR06 (1206)	1/8W	-55 ~ +155°C	150V	300V	24.9Ω - 50KΩ			±5
					24.9Ω - 500KΩ	4.7Ω - 1MΩ	±10 ±15	
AR13 (1210)	1/5W	-55 ~ +155°C	150V	300V	24.9Ω - 50KΩ			±5
					24.9Ω - 500KΩ	4.7Ω - 1MΩ	±10 ±15	
AR10 (2010)	1/4W	-55 ~ +155°C	150V	300V	24.9Ω - 100KΩ			±5
					24.9Ω - 500KΩ	4.7Ω - 1MΩ	±10 ±15	
AR12 (2512)	1/2W	-55 ~ +155°C	150V	300V	24.9Ω - 100KΩ			±5
					24.9Ω - 500KΩ	4.7Ω - 1MΩ	±10 ±15	

Operating Voltage= $\sqrt{P \cdot R}$  or Max. operating voltage listed above, whichever is lower.

Overload Voltage= $2.5 \cdot \sqrt{P \cdot R}$  or Max. overload voltage listed above, whichever is lower.

## High Power Rating Electrical Specifications

Item Type	Power Rating at 70°C	Operating Temp. Range	Max. Operating Voltage	Max. Overload Voltage	Resistance Range					TCR (PPM/°C)
					±0.01%	±0.05%	±0.1%	±0.25%	±0.5%	
AR03 (0603)	1/10W	-55 ~ +155°C	75V	150V	24.9Ω - 15KΩ					±5
	1/6W				24.9Ω - 100KΩ	4.7Ω - 332KΩ	4.7Ω - 332KΩ		±10	
				4.7Ω - 1MΩ			±15			
			100V	150V	—	10Ω - 332KΩ			±25	
									±50	
AR05 (0805)	1/8W	-55 ~ +155°C	150V	300V	24.9Ω - 30KΩ					±5
	1/4W				24.9Ω - 200KΩ	4.7Ω - 511KΩ	4.7Ω - 511KΩ		±10	
				4.7Ω - 1MΩ			±15			
			150V	300V	—	10Ω - 500KΩ			±25	
									±50	
AR06 (1206)	1/4W	-55 ~ +155°C	200V	400V	24.9Ω - 50KΩ					±5
	1/3W				24.9Ω - 500KΩ	4.7Ω - 1MΩ			±10	
				4.7Ω - 1MΩ			±15			
			200V	400V	—	10Ω - 1MΩ			±25	
									±50	
AR13 (1210)	1/3W	-55 ~ +155°C	200V	400V	24.9Ω - 50KΩ					±5
					24.9Ω - 500KΩ	4.7Ω - 1MΩ			±10	
									±15	
									±25	
									±50	

Operating Voltage= $\sqrt{P \cdot R}$  or Max. operating voltage listed above, whichever is lower.

Overload Voltage= $2.5 \cdot \sqrt{P \cdot R}$  or Max. overload voltage listed above, whichever is lower.

■ Lower Resistance: 1~10Ω ; High Power Rating

## Environmental Characteristics

Item	Requirement		Test Method
	Tol. ≤ 0.05%	Tol. > 0.05%	
Temperature Coefficient of Resistance (T.C.R.)	As Spec.		+25/-55/+25/+125/+25°C
Short Time Overload	ΔR±0.05%	ΔR±0.2%	RCWV*2.5 or Max. overload voltage for 5 seconds
	ΔR±0.2% for high power rating		
Insulation Resistance	>1000 MΩ		Apply 100V <sub>DC</sub> for 1 minute
Endurance	ΔR±0.05%	ΔR±0.2%	70±2°C, Max. working voltage for 1000 hrs with 1.5 hrs "ON" and 0.5 hrs "OFF"
	>7kΩ ΔR±0.5%		
	ΔR±0.5% for high power rating		
Damp Heat with Load	ΔR±0.05%	ΔR±0.3%	40±2°C, 90~95% R.H. Max. working voltage for 1000 hrs with 1.5 hrs "ON" and 0.5 hrs "OFF"
	ΔR±0.5% for high power rating		
Bending Strength	ΔR±0.05%	ΔR±0.2%	Bending amplitude 3 mm for 10 seconds
Solderability	95% min. coverage		245±5°C for 3 seconds
Resistance to Soldering Heat	ΔR±0.05%	ΔR±0.2%	260±5°C for 10 seconds
Dielectric Withstand Voltage	By Type		Max. overload voltage for 1 minute
Thermal Shock	ΔR±0.05%	ΔR±0.25%	-55°C~150°C, 100 cycles
Low Temperature Operation	ΔR±0.05%	ΔR±0.2%	1 hour, -65°C, followed by 45 minutes of RCWV
	ΔR±0.5% for high power rating		

■ Reference Standards: MIL-STD-202, JIS-C 5201-1

■ Storage Temperature: 25±3°C; Humidity < 80%RH

# ■ Packaging

Packaging Quantity & Reel Specifications

Unit: mm

Type	ΦA	ΦB	ΦC	W	T	Paper Tape (EA)	Embossed Plastic Tape (EA)
AR01	178.0 ± 1.0	60.0 + 1.0	13.5 ± 0.7	9.5 ± 1.0	11.5 ± 1.0	10,000	-
AR02	178.0 ± 1.0	60.0 + 1.0	13.5 ± 0.7	9.5 ± 1.0	11.5 ± 1.0	10,000	-
AR03	178.0 ± 1.0	60.0 + 1.0	13.5 ± 0.7	9.5 ± 1.0	11.5 ± 1.0	5,000	-
AR05	178.0 ± 1.0	60.0 + 1.0	13.5 ± 0.7	9.5 ± 1.0	11.5 ± 1.0	5,000	-
AR06	178.0 ± 1.0	60.0 + 1.0	13.5 ± 0.7	9.5 ± 1.0	11.5 ± 1.0	5,000	-
AR13	178.0 ± 1.0	60.0 + 1.0	13.5 ± 0.7	9.5 ± 1.0	11.5 ± 1.0	5,000	-
AR10	178.0 ± 1.0	60.0 + 1.0	13.5 ± 0.7	13.5 ± 1.0	15.5 ± 1.0	-	4,000
AR12	178.0 ± 1.0	60.0 + 1.0	13.5 ± 0.7	13.5 ± 1.0	15.5 ± 1.0	-	4,000

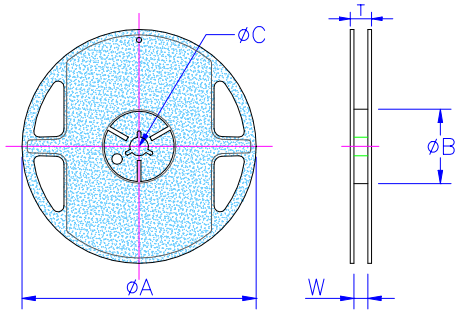

## Paper Tape Specifications

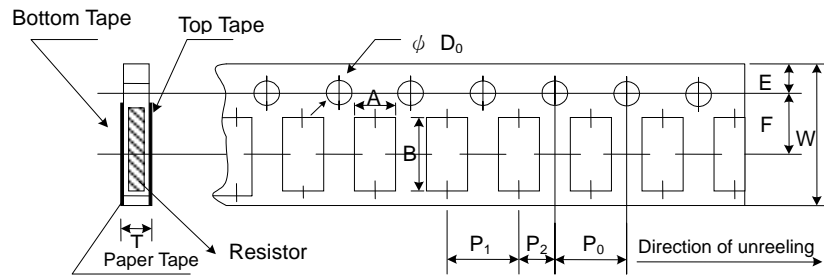

Unit: mm

Type	A	B	W	E	F	P <sub>0</sub>	P <sub>1</sub>	P <sub>2</sub>	ΦD <sub>0</sub>	T
AR01	0.40±0.05	0.70±0.05	8.00±0.10	1.75±0.05	3.5±0.05	4.00±0.10	2.00±0.05	2.00±0.05	1.55±0.03	0.42±0.02
AR02	0.70±0.05	1.16±0.05	8.00±0.10	1.75±0.05	3.5±0.05	4.00±0.10	2.00±0.05	2.00±0.05	1.55±0.05	0.40±0.03
AR03	1.10±0.05	1.90±0.05	8.00±0.10	1.75±0.05	3.5±0.05	4.00±0.10	4.00±0.10	2.00±0.05	1.55±0.05	0.60±0.03
AR05	1.60±0.05	2.37±0.05	8.00±0.10	1.75±0.05	3.5±0.05	4.00±0.10	4.00±0.10	2.00±0.05	1.55±0.05	0.75±0.05
AR06	2.00±0.05	3.55±0.05	8.00±0.10	1.75±0.05	3.5±0.05	4.00±0.10	4.00±0.10	2.00±0.05	1.55±0.05	0.75±0.05
AR13	2.75±0.05	3.40±0.05	8.00±0.10	1.75±0.05	3.5±0.05	4.00±0.05	4.00±0.10	2.00±0.05	1.60±0.10	0.75±0.05

## Embossed Plastic Tape Specifications

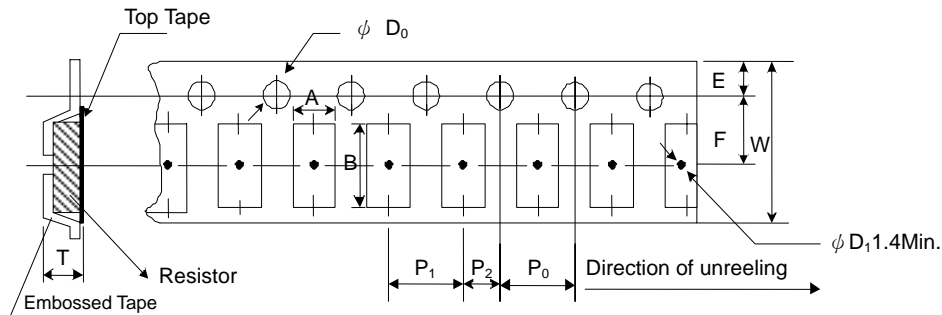

Unit: mm

Type	A	B	W	E	F	P <sub>0</sub>	P <sub>1</sub>	P <sub>2</sub>	ΦD <sub>0</sub>	T
AR10	2.85±0.10	5.45±0.10	12.0±0.10	1.75±0.10	5.5±0.05	4.00±0.05	4.00±0.10	2.00±0.05	1.50±0.10	1.00±0.20
AR12	3.40±0.10	6.65±0.10	12.0±0.10	1.75±0.10	5.5±0.05	4.00±0.05	4.00±0.10	2.00±0.05	1.50±0.10	1.00±0.20

## ■ Recommend Land Pattern

Unit: mm

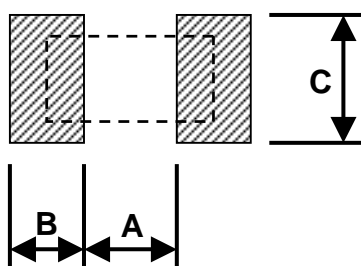

Type	A	B	C
AR01	0.25	0.30	0.40±0.2
AR02	0.50	0.50	0.60±0.2
AR03	0.80	1.00	0.90±0.2
AR05	1.00	1.00	1.35±0.2
AR06	2.00	1.15	1.70±0.2
AR13	2.00	1.15	2.50±0.2
AR10	3.60	1.40	2.50±0.2
AR12	4.90	1.60	3.10±0.2