



FNK4421

P-Channel MOSFET

GENERAL DESCRIPTION

The FNk4421 uses advanced trench to provide excellent $R_{ds(on)}$, low gate charge and operation with gate voltage as low -1.0V.

This device is suitable for use as a load switch or in PWM application

FEATURES

- $V_{DS} = -20V, I_D = -7A$
- $R_{DS(ON)} < 35m\Omega @ V_{GS} = -2.5V$
- $R_{DS(ON)} < 25m\Omega @ V_{GS} = -4.5V$
- Capable doing Cu wire bonding

APPLICATIONS

- Power Management in Note book
- Portable Equipment
- Battery Powered System
- Load Switch
- DSC

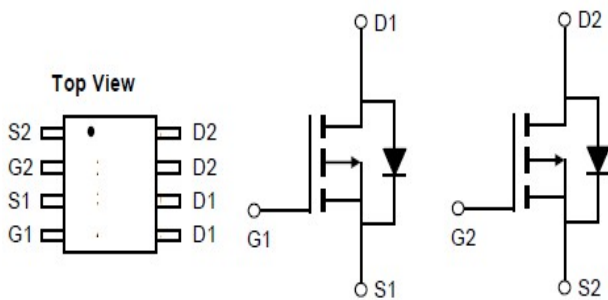



FNK4421

P-Channel MOSFET

Absolute Maximum Ratings (TA=25°C Unless Otherwise Noted)

Parameter	Symbol	Limit	Unit
Drain-Source Voltage	V	-20	V
Gate-Source Voltage	V	±12	V

Electrical Characteristics (Tj =25°C Unless Otherwise Specified)

Symbol	Parameter	Limit	Min	Typ	Max	Unit
STATIC						
BV _{DSS}	Drain-Source Breakdown Voltage	V _{GS} =0, I _D =-250μA	-20			V
V _{GS(th)}	Gate Threshold Voltage	V _{DS} =V _{GS} , I _D =-250μA	-0.4		-1.0	V
I _{GSS}	Gate Body Leakage	V _{DS} =0V, V _{GS} =±12V			±100	nA
I _{DSS}	Zero Gate Voltage Drain Current	V _{DS} =-20V, V _{GS} =0V			1	μA
R _{DS(ON)}	Drain-Source On-Resistance	V _{GS} =-4.5V, I _D =-7A		21	25	mΩ
		V _{GS} =-2.5V, I _D =-5A		29	35	
V _{SD}	Diode Forward Voltage	I _S =-1A, V _{GS} =0V		-1.10	-1.2	V
DYNAMIC						
Q _g	Total Gate Charge	V _{ds} = -4V, I _d =-7A, V _{gs} =-4.5V		12		nC
	Total Gate Charge			7.8		
Q _{gs}	Gate-Source Charge	V _{ds} = -4V, I _d =-7A, V _{gs} =-4.5V		1.2		nC
Q _{gd}	Gate-Drain Charge			1.6		
C _{iss}	Input capacitance	V _{ds} = -4V, V _{gs} =0V F=1.0MHZ		1340		pF
C _{oss}	Output Capacitance			574		
C _{rss}	Reverse Transfer Capacitance			370		
R _g	Gate-Resistance	V _{DS} =0V, V _{GS} =0V, f=1MHz		1		Ω
t _{d(on)}	Turn-On Delay Time	V _{DD} =-4V, I _D =-3.3A, R _L =-1.2Ω V _{GEN} =-4.5V, R _g =1Ω		12		ns
t _r	Turn-On Rise Time			35		
t _{d(off)}	Turn-Off Delay Time			30		
t _f	Turn-Off Fall Time			10		

Notes: a. Based on epoxy or solder paste and bond wire Au or Cu 2mil×8(S), 2mil×2(G) on each die of SOP-8 package.

b. Pulse test; pulse width ≤ 300us, duty cycle ≤ 2%.