

# Application of AT3216/AT5020 Series Multilayer Chip Antenna

## Features

- ❖ Monolithic SMD with small, low-profile and light-weight type.
- ❖ Wide bandwidth

## Applications

- ❖ Dual-band 2.4/5.5 GHz WLAN



## Terminal Configuration

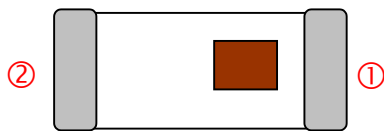

| No. | Terminal Name | No. | Terminal Name |
|-----|---------------|-----|---------------|
| ①   | Feeding Point | ②   | NC            |

## Dimensions and Recommended PC Board Pattern

❖ AT3216-B5R5HAA\_

Unit: mm

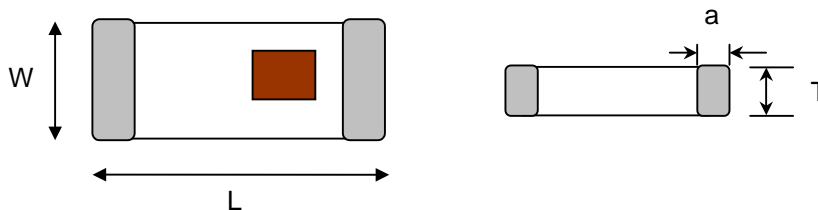

| Mark       | L       | W       | T                | a       |
|------------|---------|---------|------------------|---------|
| Dimensions | 3.2±0.2 | 1.6±0.2 | 1.3+<br>0.1/-0.2 | 0.5±0.3 |

❖ AT5020-B2R8HAA\_

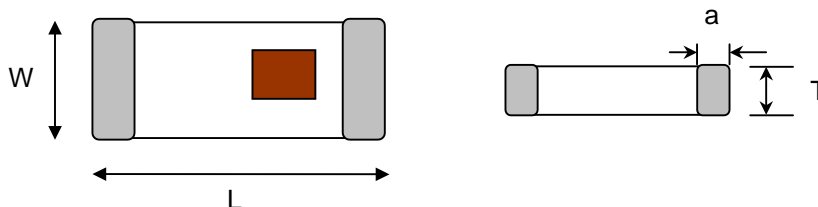

|            | L       | W       | T       | a       |
|------------|---------|---------|---------|---------|
| Dimensions | 5.0±0.2 | 2.0±0.2 | 1.1±0.2 | 0.5±0.3 |

❖ PCB and Matching Circuits

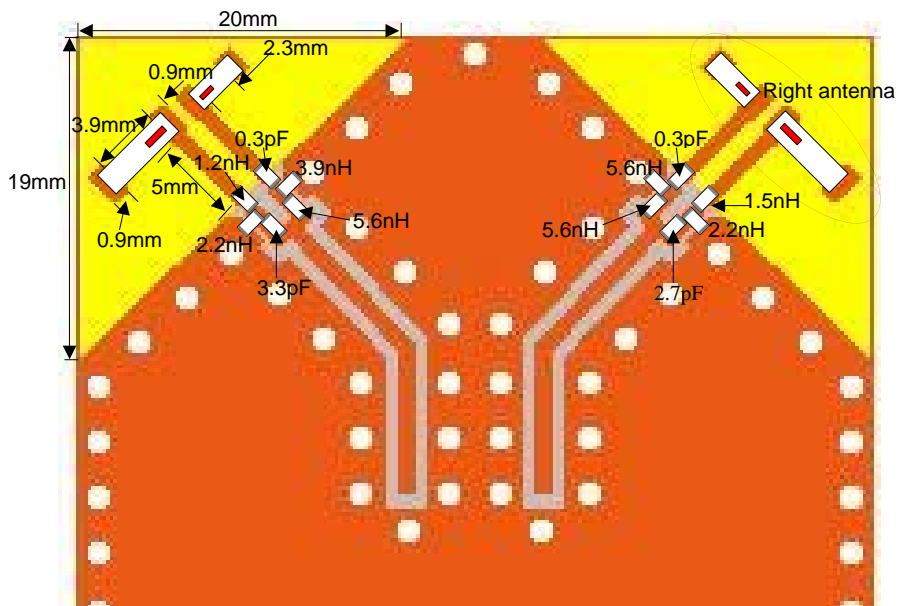

\*Line width should be designed to match  $50\Omega$  characteristic impedance, depending on PCB material and thickness.

**Typical Electrical Characteristics (T=25°C)**

❖ Test Board

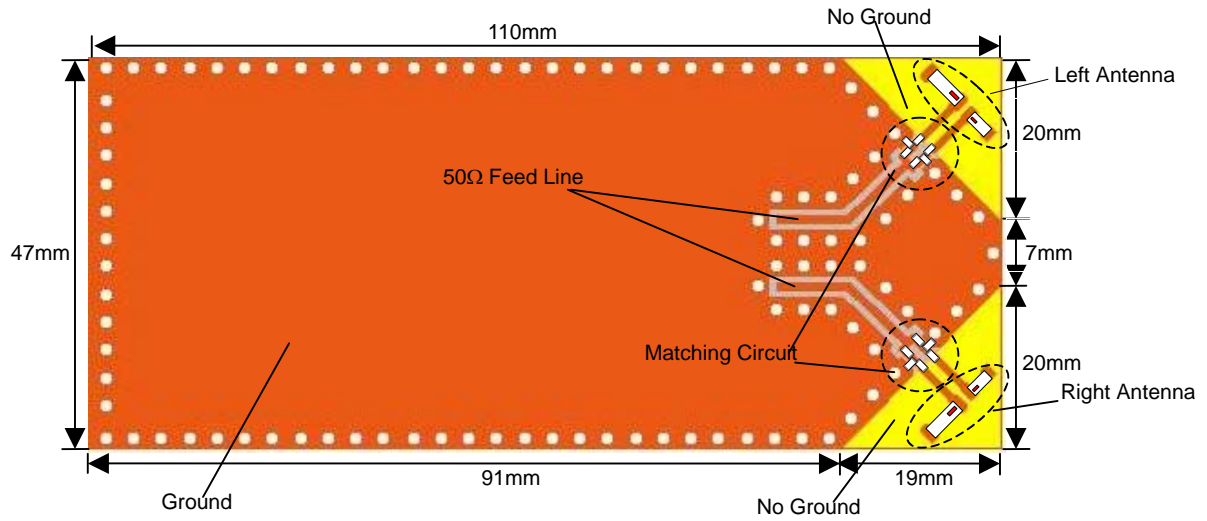

❖ Return Loss (Test board in plastic case)

(a) Left Antenna

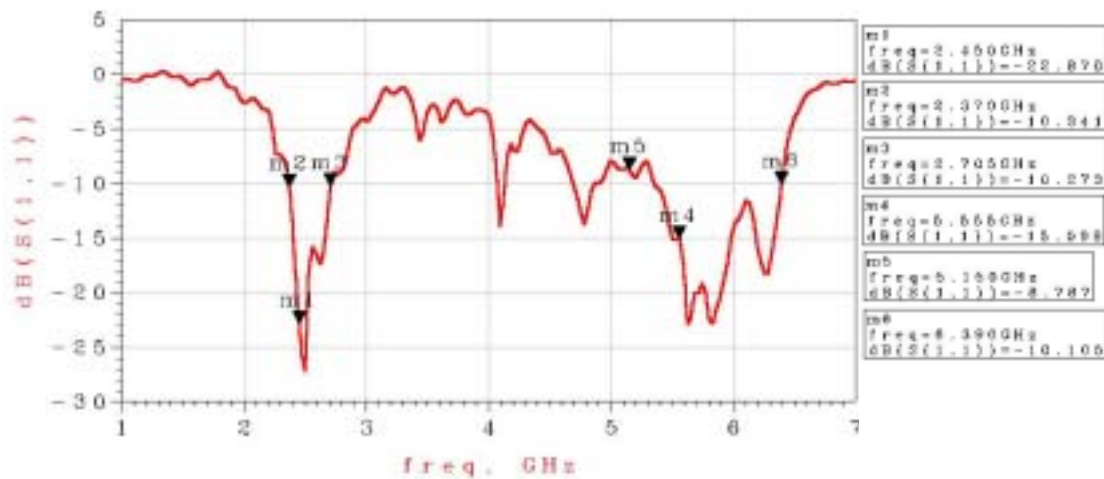

(b) Right Antenna

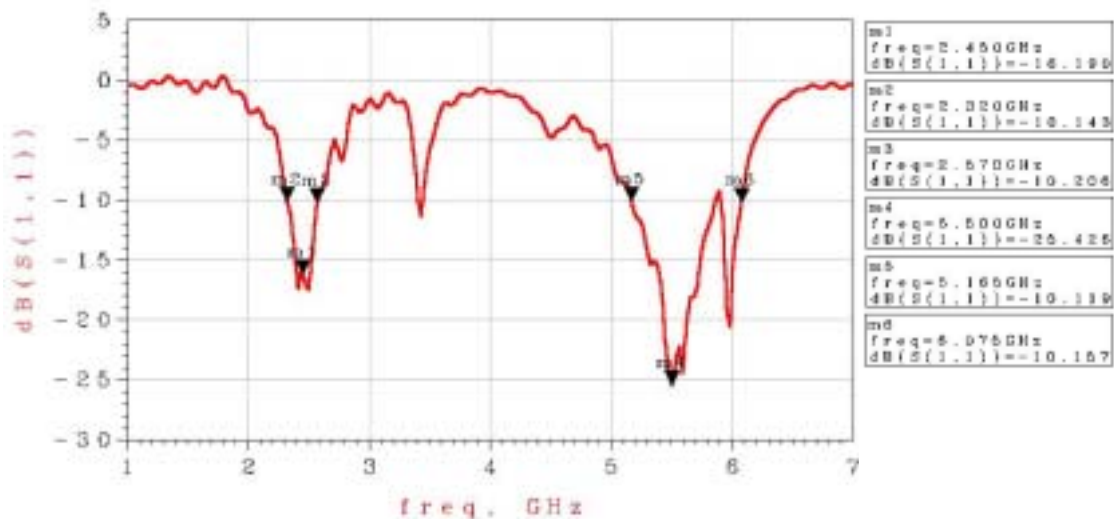

❖ Radiation Patterns (Test board in case)

(a) Left Antenna

XY-V/XY-H

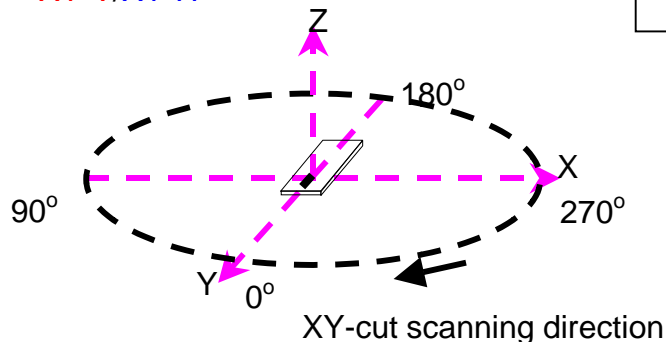

XY cut @2.45GHz  
— Vertical  
- - Horizontal

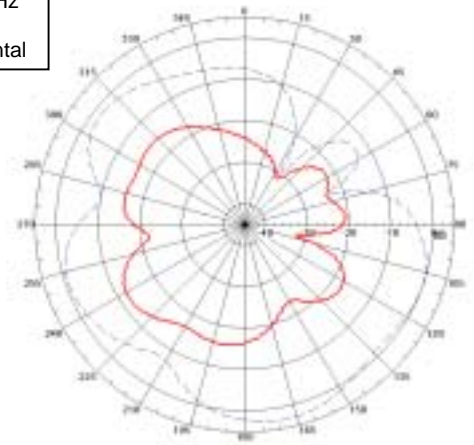

XZ-V/XZ-H

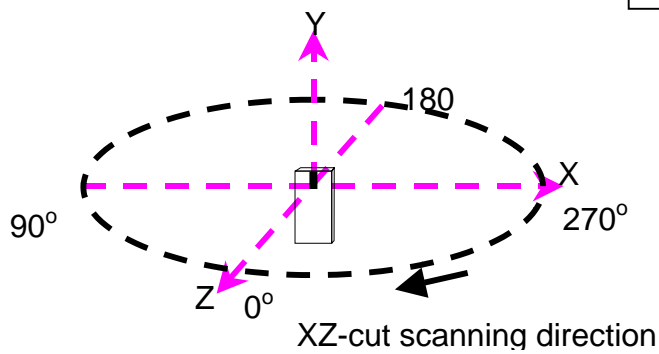

XZ cut @2.45GHz  
— Vertical  
- - Horizontal

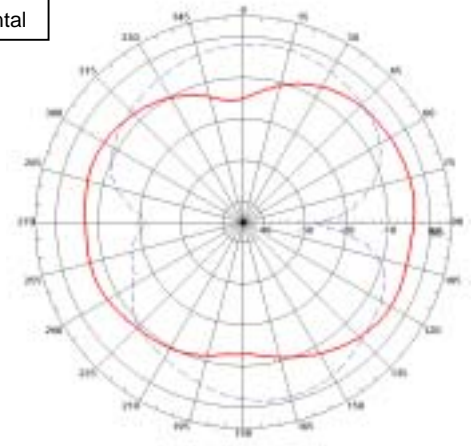

YZ-V/YZ-H

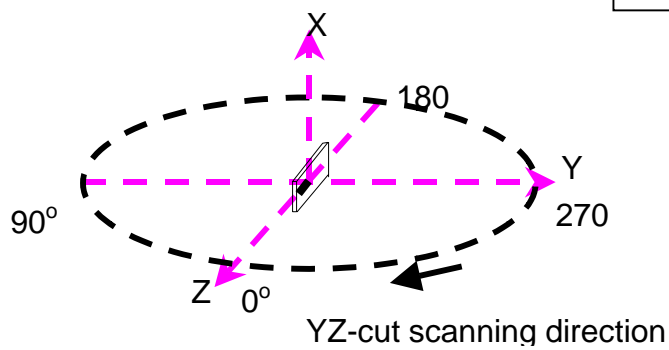

YZ cut @2.45GHz  
— Vertical  
- - Horizontal

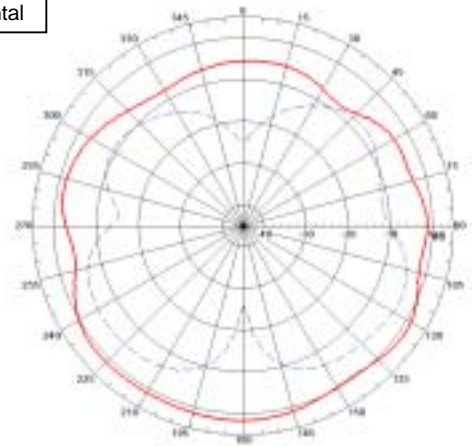

XY-V/XY-H

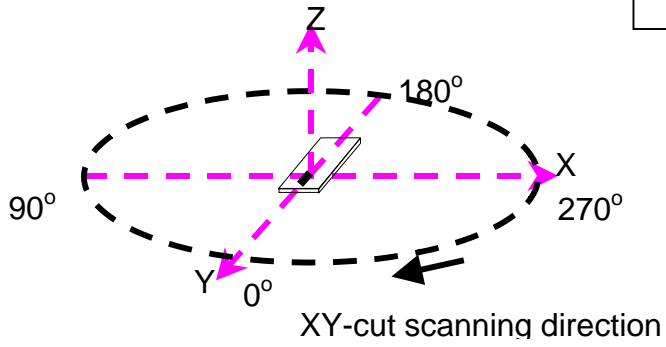

XY cut @5.5GHz  
 — Vertical  
 - - Horizontal

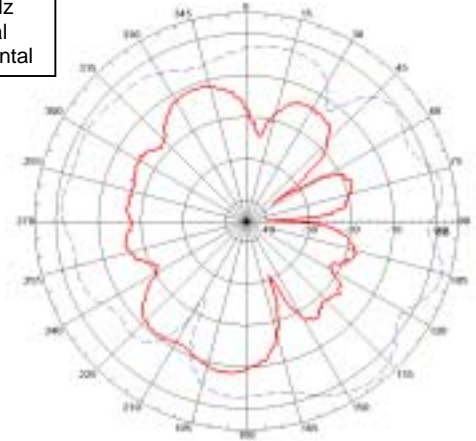

XZ-V/XZ-H

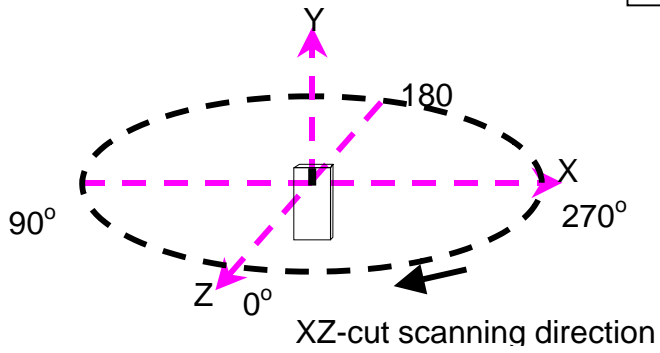

XZ cut @5.5GHz  
 — Vertical  
 - - Horizontal

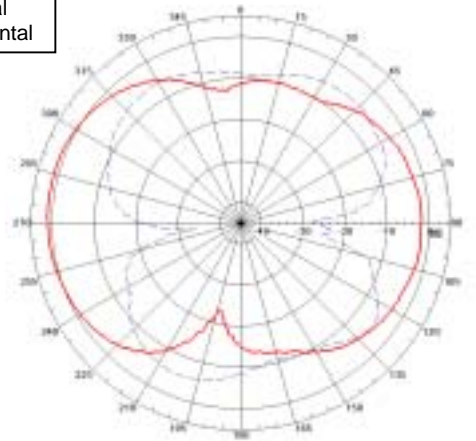

YZ-V/YZ-H

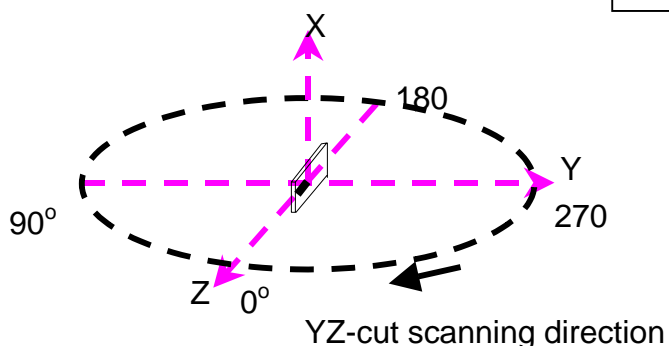

YZ cut @5.5GHz  
 — Vertical  
 - - Horizontal

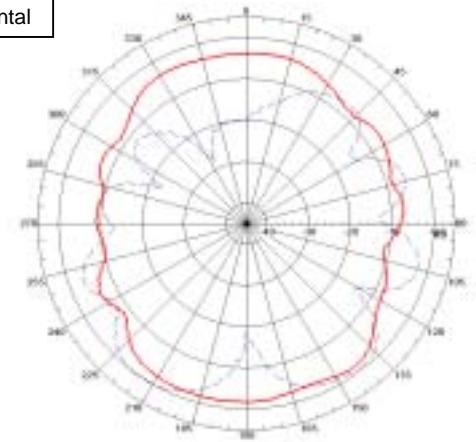

(b) Right Antenna

XY-V/XY-H

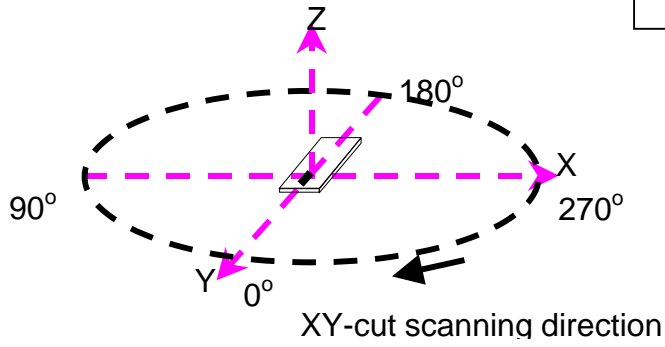

XY cut @2.45GHz  
— Vertical  
- - - Horizontal

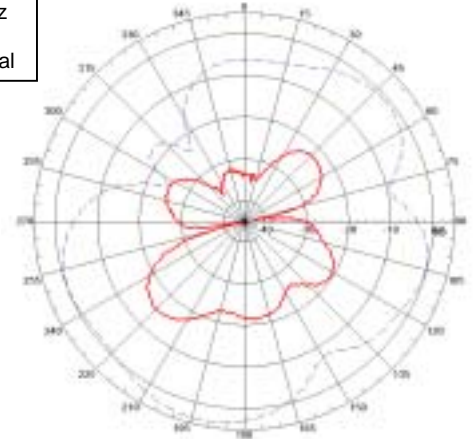

XZ-V/XZ-H

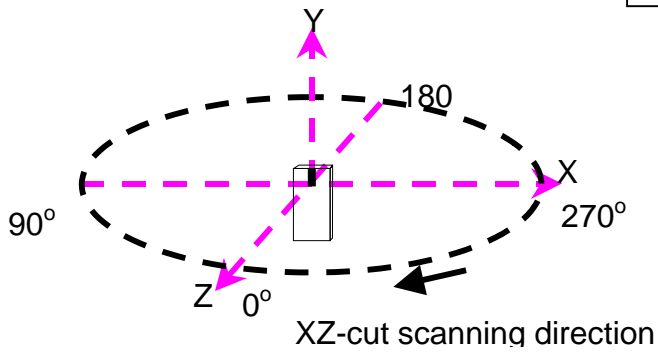

XZ cut @2.45GHz  
— Vertical  
- - - Horizontal

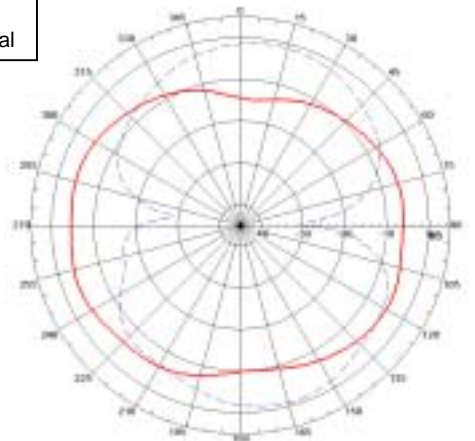

YZ-V/YZ-H

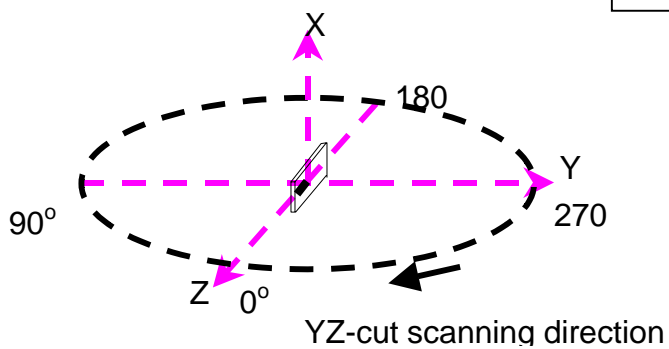

YZ cut @2.45GHz  
— Vertical  
- - - Horizontal

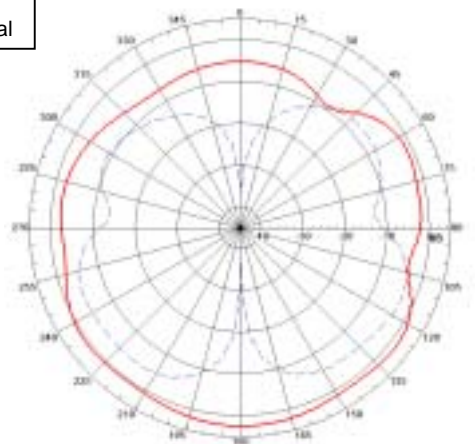

XY-V/XY-H

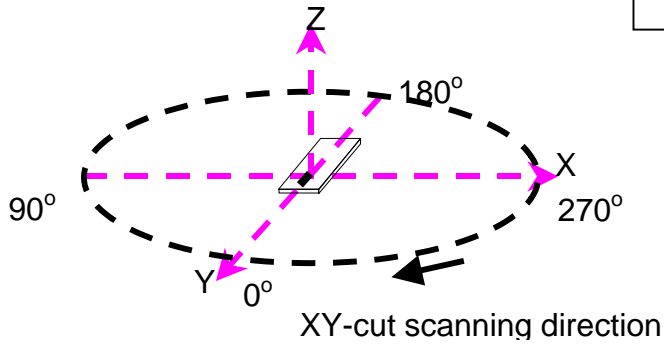

XY cut @5.5GHz  
— Vertical  
- - - Horizontal

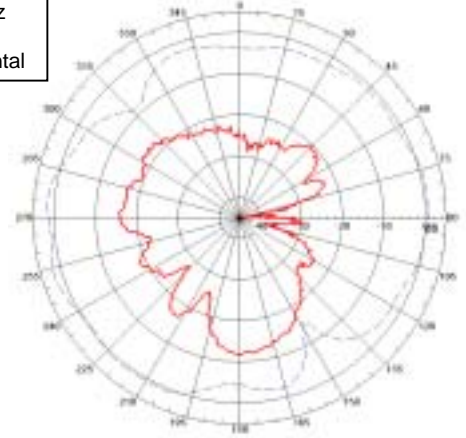

XZ-V/XZ-H

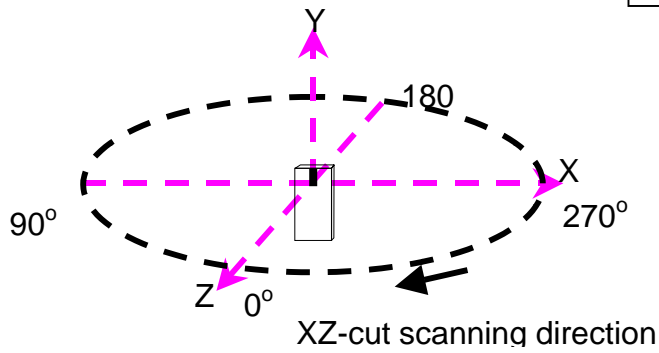

XZ cut @5.5GHz  
— Vertical  
- - - Horizontal

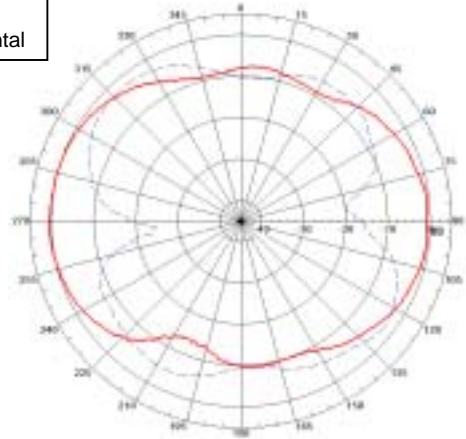

YZ-V/YZ-H

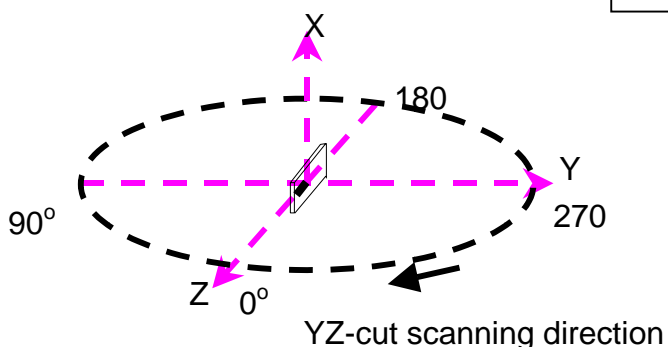

YZ cut @5.5GHz  
— Vertical  
- - - Horizontal

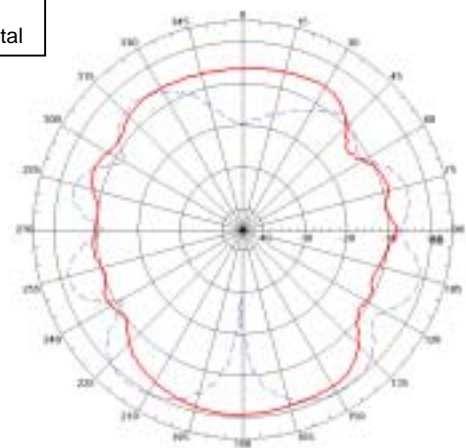

(c) Gain

|                 |         |    | V          |            | H          |            |
|-----------------|---------|----|------------|------------|------------|------------|
|                 |         |    | Peak (dBi) | Avg. (dBi) | Peak (dBi) | Avg. (dBi) |
| Left<br>Antenna | 2.45GHz | XY | -12.30     | -18.08     | 2.88       | -2.67      |
|                 |         | XZ | -3.59      | -7.02      | -1.21      | -5.37      |
|                 |         | YZ | 1.47       | -1.57      | -3.76      | -8.50      |
|                 | 5.5GHz  | XY | -8.45      | -14.70     | 3.30       | -1.81      |
|                 |         | XZ | 1.15       | -3.49      | -4.93      | -8.73      |
|                 |         | YZ | -1.73      | -5.00      | 0.07       | -6.11      |

|                  |         |    | V          |            | H          |            |
|------------------|---------|----|------------|------------|------------|------------|
|                  |         |    | Peak (dBi) | Avg. (dBi) | Peak (dBi) | Avg. (dBi) |
| Right<br>Antenna | 2.45GHz | XY | -15.36     | -23.14     | 3.60       | -2.06      |
|                  |         | XZ | -3.80      | -6.79      | -1.06      | -5.10      |
|                  |         | YZ | 2.34       | -1.19      | -3.23      | -7.89      |
|                  | 5.5GHz  | XY | -11.85     | -19.21     | 1.94       | -1.36      |
|                  |         | XZ | 0.42       | -3.60      | -2.38      | -6.58      |
|                  |         | YZ | -0.70      | -5.62      | 0.74       | -4.73      |

**Advanced Ceramic X Corp.**

16 Tzu Chiang Road, Hsinchu Industrial District Hsinchu Hsien 303, Taiwan

TEL:886-3-5987008 FAX:886-3-5987001

E-mail: [acx@acxc.com.tw](mailto:acx@acxc.com.tw) <http://www.acxc.com.tw>