

Description

PESD0402AS12 polymeric ESD suppressor help protect sensitive electronic equipment against electrostatic discharge (ESD). This device is an ultra low capacitance PESD product designed to protect very high speed data interfaces. PESD0402AS12 has a typical capacitance of only 0.1pF (I/O to GND), and it can be used to meet the ESD immunity requirements of IEC61000-4-2 (15KV air, 8KV contact discharge).

Features

- The best ESD protection for high speed, low voltage applications
- RoHS compliant and halogen free
- Ultra low capacitance, 0.1pF (typ.)
- Low leakage current (<100nA)
- Fast response time (<1ns)
- Bi-directional, single line protection
- Surface mount

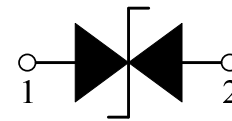

Equivalent Circuit

Materials Information

RoHS Compliant

Halogen Free

RoHS



Applications

- HDTV/Set-Top Box
- Laptop/Desktop Computer
- Smart phone/Mobile Internet Device
- Antennas (cell phones, GPS...)
- High Definition Multi-Media Interface (HDMI)
- High speed Ethernet
- USB 2.0 and USB 3.0
- Lightning and Thunder bolt Interface

Caution: This component is designed for signal line protection only, not intended to be used under bias, not for application with power line.

General Characteristics

Parameter	Value	Unit
Contact Discharge Voltage Per IEC61000-4-2	8K	V
Air Discharge Voltage Per IEC61000-4-2	15K	V
Maximum Operating Temperature	-40 to +90	°C
Maximum Storage Temperature	-55 to +125	°C

Electrical Characteristics (T_A =25°C)

Parameter	Symbol	Test Conditions	Min.	Typ.	Max.	Units
Continuous Operating Voltage	V _{DC}	---	---	---	12	V
Trigger Voltage	V _T	IEC61000-4-2 8KV contact discharge	---	450	---	V
Clamping Voltage	V _C	IEC61000-4-2 8KV contact discharge	---	40	---	V
Leakage Current	I _L	DC 12V shall be applied on component	---	---	100	nA
Capacitance	C _P	V _R =0V,f=1MHZ	---	0.1	0.15	pF
ESD Pulse Withstand	Pulses	IEC61000-4-2 8KV contact discharge	100	---	---	---

Notes:

1. Trigger and clamping voltage are measured per IEC 61000-4-2, 8KV contact discharge method.
2. After reliability tests such as high Temp storage, Temp cycles, continuous ESD strike etc, the maximum leakage current is less than 1uA.

Package Dimension

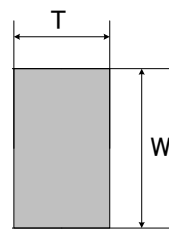
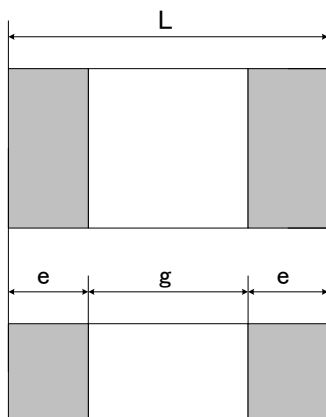

(unit : mm)

Mark	Dimension
L	1.00±0.15
W	0.50±0.15
T	0.5 max
e	0.25±0.10
g	0.50 min

Taping Specification

1. Tape Dimension

Unit: Millimeters

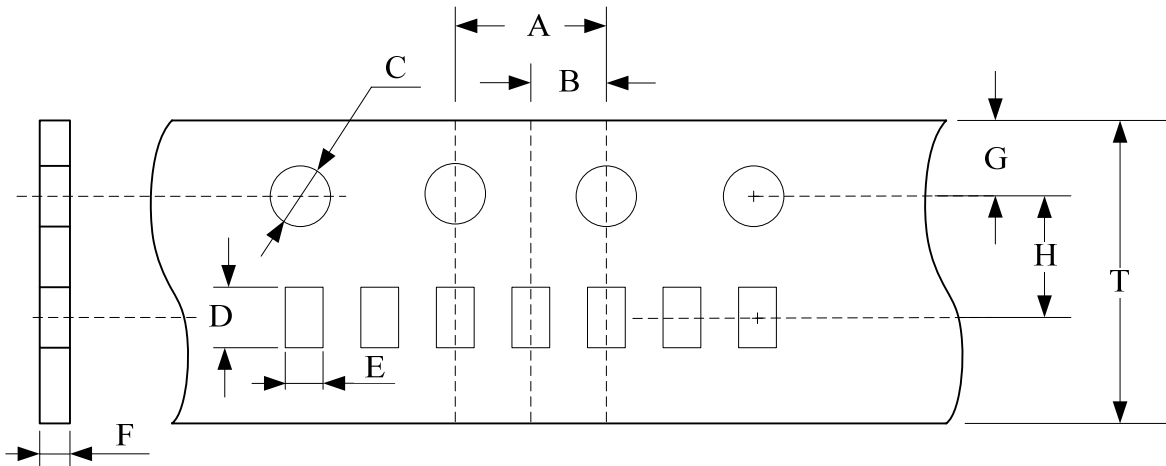

A	B	C	D	E	F	G	H	T
4.00±0.10	2.00±0.10	∅1.50±0.10	1.19±0.05	0.70±0.05	0.48±0.05	1.75±0.10	3.50±0.05	8.00±0.30

2. Reel Dimension

Unit: Millimeters

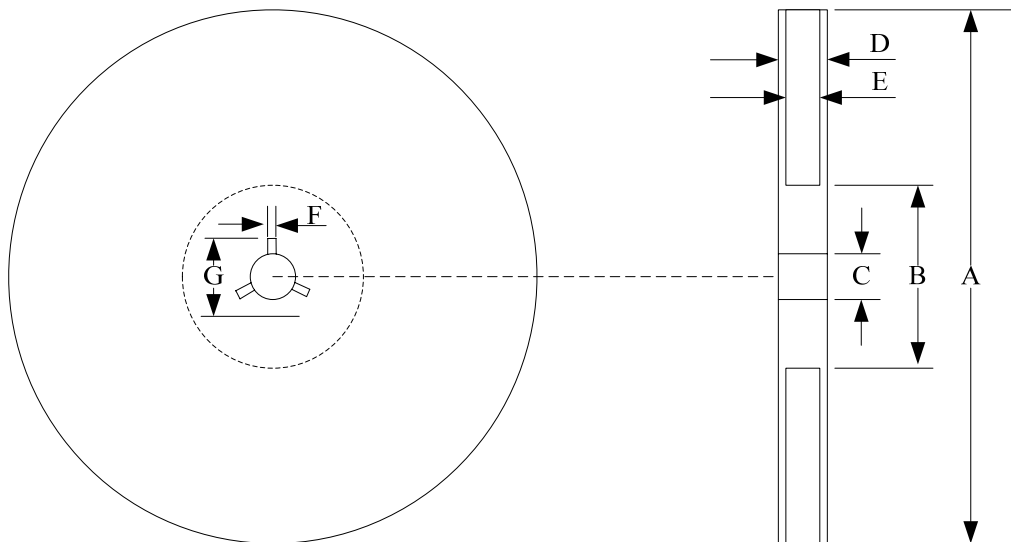

A	B min.	C	D	E	F	G
178.0 ±2.0	57.0	13.0±0.5	13.0±1.0	9.0±0.5	2.0 ±0.5	21.0±0.8

Part Numbering

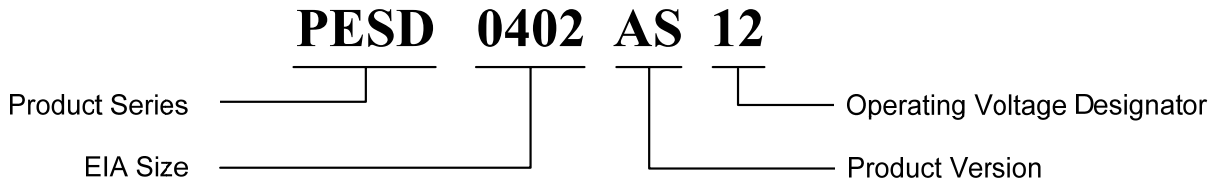

Soldering Parameters

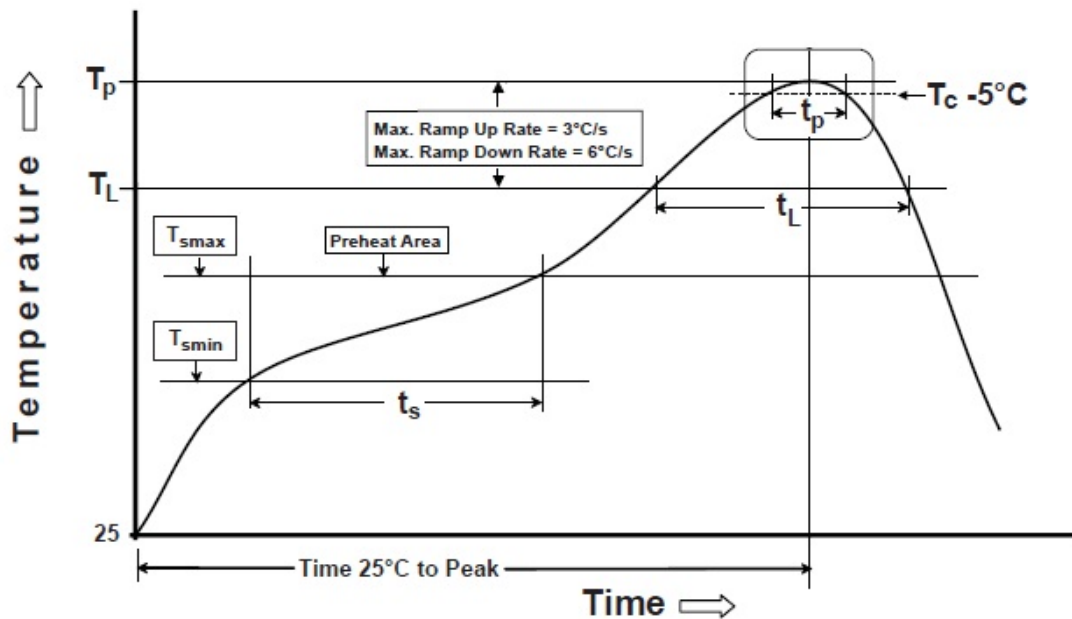

Profile Feature	Pb-Free Assembly
Pre Heat	
Temperature Min (T_{smin})	150 °C
Temperature Max (T_{smax})	200 °C
Time (t_s) from (T_{smin} to T_{smax})	60-120 seconds
Ramp-up Rate (T_L to T_p)	3 °C/second max.
Liquidus temperature (T_L)	217 °C
Time (t_L) maintained above T_L	60-150 seconds
Peak package body temperature (T_p)	260 ^{+0/-5} °C
Time (t_p)* within 5 °C of the specified classification temperature (T_c)	30* seconds
Ramp-down Rate (T_p to T_L)	6 °C/second max.
Time 25 °C to peak temperature	8 minutes max.
* Tolerance for peak profile temperature (T_p) is defined as a supplier minimum and a user maximum.	