

CERMET SINGLE TURN TYPE

JP-B series

RoHS compliant

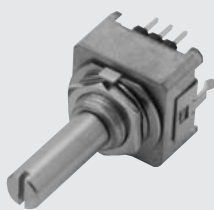

JP-16B



JP-30B

Basic construction

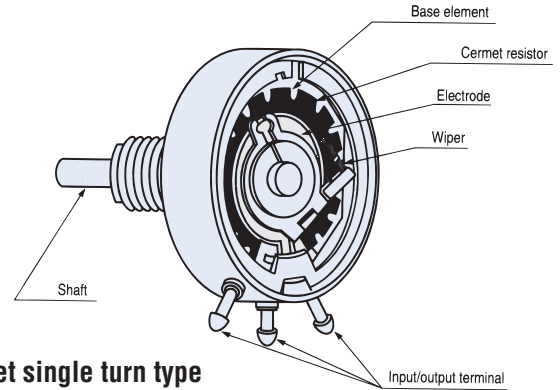

Cermet single turn type

FEATURES

- Cost effective (In house comparison)
- High resolution (Essentially infinite)
- RoHS compliant

PART NUMBER DESIGNATION

JP-16B-C1k

Series name
 JP-16B : For manual setting
 JP-30B : For manual setting

Snap-in holder
 Blank : Without
 C : With

Nominal resistance value (Ω)
 500, 1 k, 2 k, 5 k, 10 k, 20 k, 50 k, 100 k

STANDARD SPECIFICATIONS

Item	Part number	JP-16B	JP-30B
Resistance tolerance	%	± 2	
Resolution		Essentially infinite	
Independent linearity	%	± 0.5	
Effective electrical angle		300° ± 1°	
Mechanical angle		300° ^{+20°} _{-0°}	
Power rating (at 40 °C)	W	1.0	1.5
Dielectric strength	Vrms	1000 1 min	
Insulation resistance	MΩ minimum	1000 (at DC500 V)	
Rotational torque	mN·m {gf·cm}	2.94 ~ 14.7 {30 ~ 150}	
Stop strength	N·m {kgf·cm} maximum	0.490 {5}	
Peak noise		2 % or 100 Ω, whichever is greater	
Temp. coefficient resistance	10 ⁻⁶ /°C	± 150	
Operating temp. range	°C	-55 ~ 85	
Maximum rotational speed	r/min	150	
Rotational life		100 thousand cycles	
Net weight	g	Approx. 16	Approx. 26
Strength of tighten screw		0.98 N·m {10 kgf·cm} maximum	

※ Perform soldering of the terminals at 380 °C for no more three seconds, and avoid applying excess heat. Also, avoid applying outside force to the terminals.
 In case of using multiturn potentiometers, when rotating the shaft to the mechanical limit, apply torque below the strength of the stopper. Also, give due consideration to thrust and radial loading.

LIST OF PART NUMBERS

Application	Series name	Mounting bracket	Nominal resistance value	Part number
For manual setting	JP-16B	Without	500 Ω	JP-16B 500
			1 kΩ	JP-16B 1 k
			2 kΩ	JP-16B 2 k
			5 kΩ	JP-16B 5 k
			10 kΩ	JP-16B 10 k
			20 kΩ	JP-16B 20 k
			50 kΩ	JP-16B 50 k
		100 kΩ	JP-16B 100 k	
		With	500 Ω	JP-16B-C 500
			1 kΩ	JP-16B-C 1 k
			2 kΩ	JP-16B-C 2 k
			5 kΩ	JP-16B-C 5 k
			10 kΩ	JP-16B-C 10 k
			20 kΩ	JP-16B-C 20 k
	50 kΩ		JP-16B-C 50 k	
	JP-30B	Without	100 kΩ	JP-16B-C 100 k
			500 Ω	JP-30B 500
			1 kΩ	JP-30B 1 k
			2 kΩ	JP-30B 2 k
			5 kΩ	JP-30B 5 k
			10 kΩ	JP-30B 10 k
20 kΩ			JP-30B 20 k	
50 kΩ	JP-30B 50 k			
100 kΩ	JP-30B 100 k			

※Verify the above part numbers when placing orders.

NOMINAL RESISTANCE VALUE • RATED VOLTAGE • RATED CURRENT

Nominal resistance value (Ω)	JP-16B		JP-30B	
	Rated voltage (V)	Rated current (mA)	Rated voltage (V)	Rated current (mA)
500	22.4	44.7	27.3	54.7
1 k	31.6	31.6	38.7	38.7
2 k	44.7	22.4	54.7	27.3
5 k	70.7	14.1	86.6	17.3
10k	100	10.0	122	12.2
20 k	141	7.07	173	8.66
50 k	224	4.47	273	5.47
100 k	316	3.16	387	3.87

RATED POWER DERATING CURVE

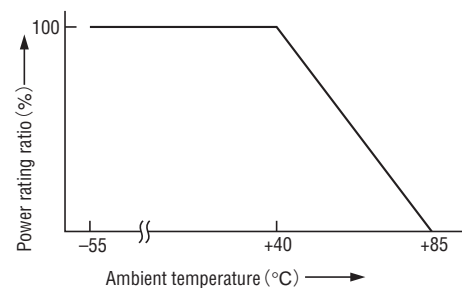

OUTLINE DIMENSIONS

Unless otherwise specified, tolerance: ± 0.5 (Unit: mm)

● **JP-16B**
For manual setting

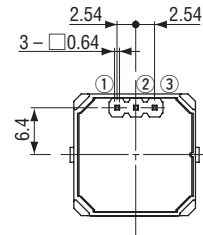
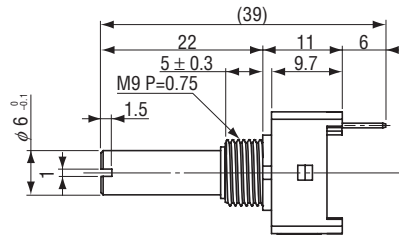
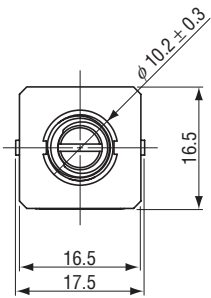

Wiring diagram

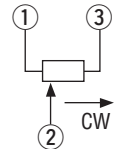

● **JP-16B-C**
For manual setting with mounting bracket

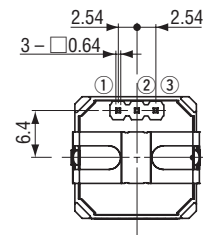
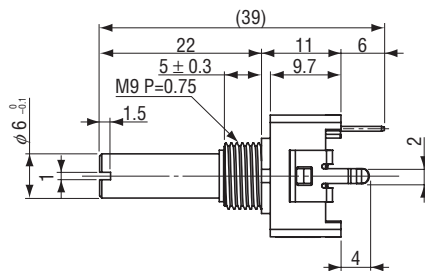
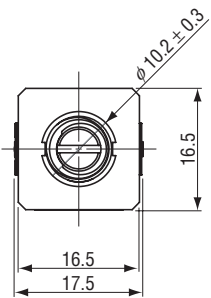

● **JP-30B**
For manual setting

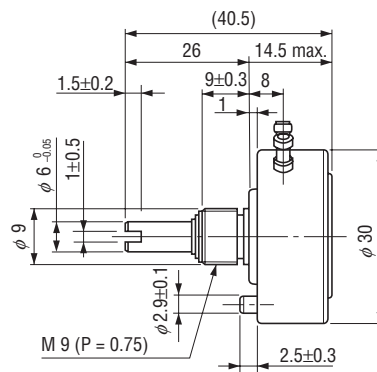
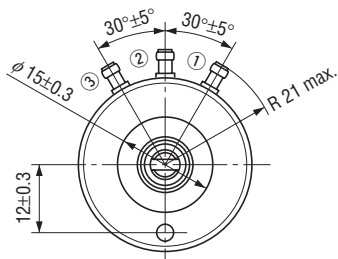

(Accessories)

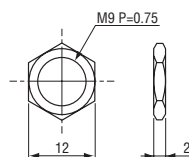

1. Nut

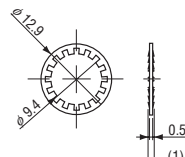

2. Washer

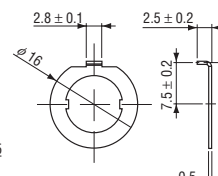

3. Locking ring (JP-16B)