

The MH276 is an integrated Latching Hall effect sensor with output drivers, mainly designed for electronic commutation of brushless DC fans. This IC includes an on chip voltage regulator, reverse battery Diode, Hall plate, amplifier, comparator, and a pair of complementary open-collector outputs (Do, DoB). It provides a one-chip solution for driving two-coil brushless DC cooling fans. A novel V_{CC} recovery circuit allows the complete two-wire fan control circuit to fit in a small four pin PB free package.

While the magnetic flux density (B) is larger than the operate point (BOP), DO will turn on (low), and meanwhile DoB will turn off (high). Each output is latched until B is lower than the release point (BRP), and then Do and DoB will change state.

For a DC fan application, it is sometimes necessary to test the reversed power connection condition. The internal protection diode only protects the chip side and not the coil side. If it is necessary to protect the coil side then add one external diode to the application circuit to block the reverse current from the coil-side. See application circuit example on page 3.

Features and Benefits

- On-chip Hall sensor with two different sensitivity and hysteresis settings
- 3.5V to 20V operating voltage
- 400mA (avg.) output sink current
- Built-in protecting diode only for chip reverse power connecting
- -20° to $+85^{\circ}$ C operating temperature
- Low cost and high sensitivity Hall Sensor

Applications

- Position Sensing
- Dual-coil Brush-less DC Motor
- Dual-coil Brush-less DC Fan
- Revolution Counting
- Speed Measurement

Functional Diagram

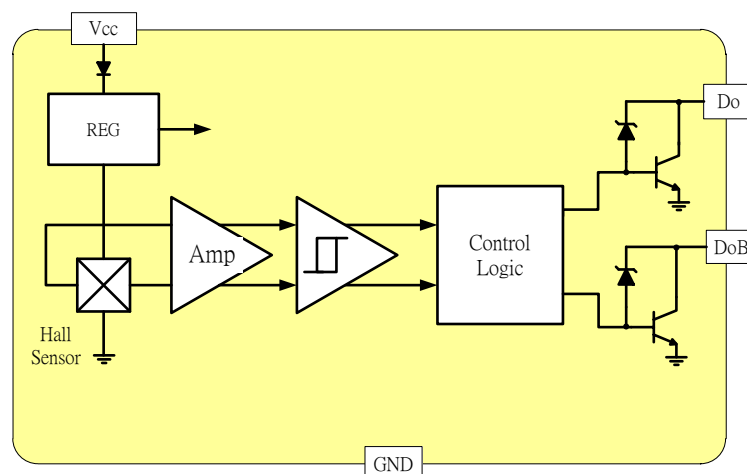

Ordering Information

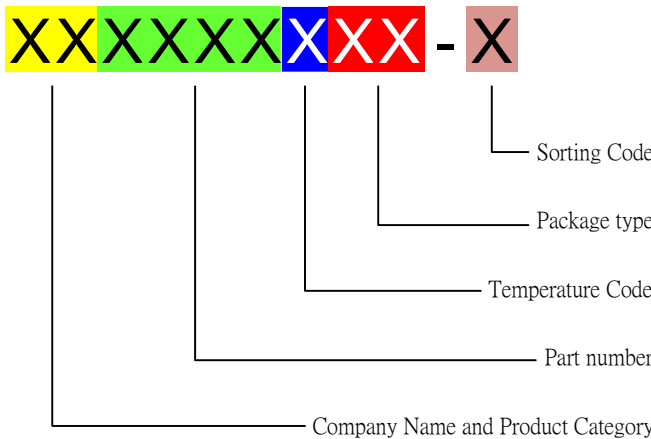
	<p>Company Name and Product Category MH:MST Hall Effect/MP:MST Power MOSFET</p> <p>Part number 181,182,183,184,185,248,249,276,477,381,381F,381R,382..... If part # is just 3 digits, the forth digit will be omitted.</p> <p>Temperature range E: 85 °C, I: 105 °C, K: 125 °C, L: 150 °C</p> <p>Package type UA:TO-92S,VK:TO-92S(4pin),VF:TO-92S(5pin),SO:SOT-23, SQ:QFN-3,ST:TSOT-23,SN:SOT-553,SF:SOT-89(5pin)</p> <p>Sorting α, β, Blank.....</p>
---	--

Part No.	Temperature Suffix	Package Type
MH276EVK-A	E (-20°C to + 85°C)	VK (4-pin TO-92S)
MH276EVK-B	E (-20°C to + 85°C)	VK (4-pin TO-92S)
MH276EVK-C	E (-20°C to + 85°C)	VK (4-pin TO-92S)

Absolute Maximum Ratings At(Ta=25°C)

Characteristics		Values	Unit
Supply voltage,(V _{cc})		20	V
Reverse Vcc Polarity Voltage,(V _{cc})		-20	V
Magnetic flux density		Unlimited	Gauss
Output “on” current,(I _{our})	Continuous	400	mA
	Hold	500	
	Peak (Start Up)	700	
Operating temperature range, (T _a)		-20 to +85	°C
Storage temperature range, (T _s)		-55 to +150	°C
Maximum Junction Temp,(T _j)		150	°C
Thermal Resistance	(θ_{JA})	227	°C/W
	(θ_{JC})	49	°C/W
Package Power Dissipation, (P _D)		550	mW

Electrical Specifications

DC Operating Parameters : $T_a = +25^\circ\text{C}$, $V_{cc} = 12\text{V}$

Parameters	Test Conditions	Min	Typ	Max	Units
Supply Voltage, (V_{cc})	Operating	3.5		20.0	V
Supply Current, (I_{cc})	$B < B_{rp}$	7	14	25.0	mA
Output Zener Breakdown, (V_z)	V_z		45	55	V
Output Saturation Voltage, (V_{sat})	$I_{out} = 400\text{mA}$, $V_{ce} = 14\text{V}$		600.0	950.0	mV
Output Leakage Current, (I_{off})	$V_{out} = 12\text{V}$, $V_{ce} = 12\text{V}$		<0.1	10.0	μA
Output Rise Time, (T_R)	$V_{cc} = 14\text{V}$, $L_1 = L_2 = 820\Omega$, $CL = 20\text{PF}$		3.0	10.0	μS
Output Falling Time, (T_F)	$V_{cc} = 14\text{V}$, $L_1 = L_2 = 820\Omega$, $CL = 20\text{PF}$		0.3	1.5	μS
Switch Time Differential, (T_s)	$V_{cc} = 14\text{V}$, $L_1 = L_2 = 820\Omega$, $CL = 20\text{PF}$		3.0	10	μS
Operate Point, (B_{OP})	"A" Grade	5		50	Gauss
	"B" Grade	5		70	Gauss
	"C" Grade			100	Gauss
Release Point, (B_{RP})	"A" Grade	-50		-5	Gauss
	"B" Grade	-70		-5	Gauss
	"C" Grade	-100			Gauss
Hysteresis, (B_{HYS})	'A' 'B' 'C' Grade		70		Gauss

Typical application circuit

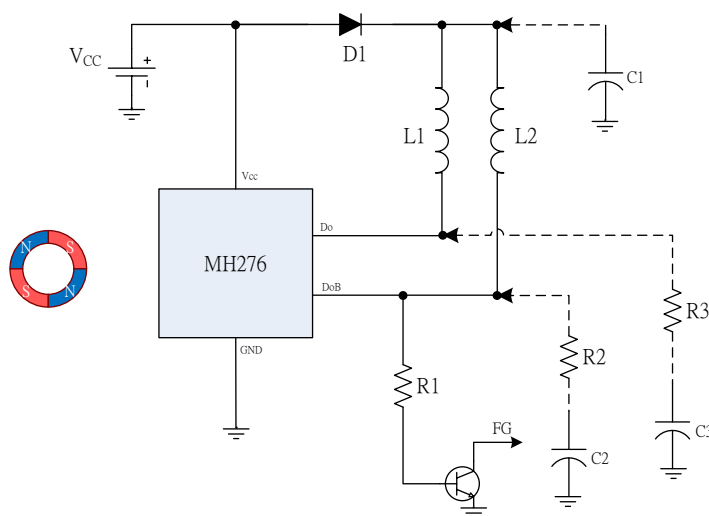

C_1 : 10/25 μF
 C_2 、 C_3 : 1 $\mu\text{F}/25\text{V}$
 D_1 : 1N4001
 R_1 : 5K Ω
 R_2 、 R_3 : 50 Ω
 Q_1 : MMBT4401

Sensor Location with Pin out and Package dimension

VK Package (To-92 4 pins)

For Halogen Free

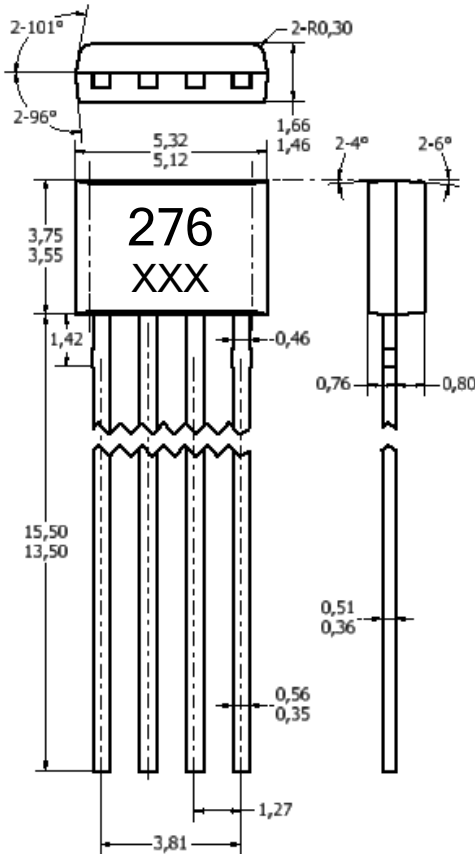

For PB free

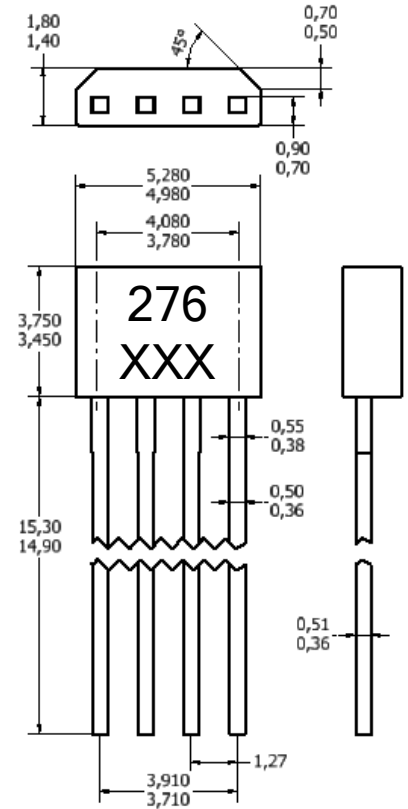

NOTES:

- 1).Controlling dimension: mm
- 2).Leads must be free of flash and plating voids
- 3).Do not bend leads within 1 mm of lead to package interface.

4).PINOUT:

Pin 1	Vcc
Pin 2	Do
Pin 3	DoB
Pin 4	GND

Hall Chip location

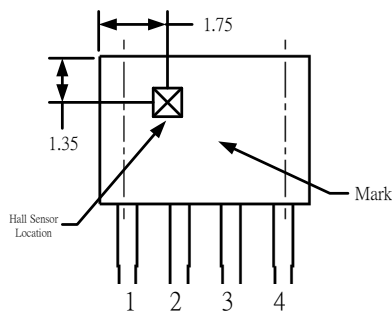

Output Pin Assignment

