



MH281 is an unipolar Hall effect sensor IC. It incorporates advanced chopper stabilization technology to provide accurate and stable magnetic switch points. The design, specifications and performance have been optimized for applications of solid state switches.

The output transistor will be switched on (BOP) in the presence of a sufficiently strong South pole magnetic field facing the marked side of the package. Similarly, the output will be switched off (BRP) in the presence of a weaker South field and remain off with “0” field.

The package type is in a Halogen Free version was verified by third party organization. Halogen Free package is available by customer’s option.

Features and Benefits

- CMOS Hall IC Technology
- Solid-State Reliability
- Chopper stabilized amplifier stage
- Unipolar, output switches with absolute value of South pole from magnet
- Operation down to 3.0V
- High Sensitivity for direct reed switch replacement applications
- 100% tested at 125°C for K Spec.
- Custom sensitivity / Temperature selection are available.

Applications

- Solid state switch
- Limit switch
- Current limit
- Interrupter
- Current sensing
- Magnet proximity sensor for reed switch replacement

Ordering Information

	<p>Company Name and Product Category MH:MST Hall Effect/MP:MST Power MOSFET</p> <p>Part number 181,182,183,184,185,248,249,276,477,381,381F,381R,382..... If part # is just 3 digits, the forth digit will be omitted.</p> <p>Temperature range E: 85 °C, I: 105 °C, K: 125 °C, L: 150 °C</p> <p>Package type UA:TO-92S,VK:TO-92S(4pin),VF:TO-92S(5pin),SO:SOT-23, SQ:QFN-3,ST:TSOT-23,SN:SOT-553,SF:SOT-89(5pin)</p> <p>Sorting α, β, Blank.....</p>
--	---

Part No.	Temperature Suffix	Package Type
MH281KUA	K (-40°C to + 125°C)	UA (TO-92S)
MH281KSO	K (-40°C to + 125°C)	SO (SOT-23)
MH281EUA	E (-40°C to + 85°C)	UA (TO-92S)
MH281ESO	E (-40°C to + 85°C)	SO (SOT-23)

KUA spec is using in industrial and automotive application. Special Hot Testing is utilized.

Functional Diagram

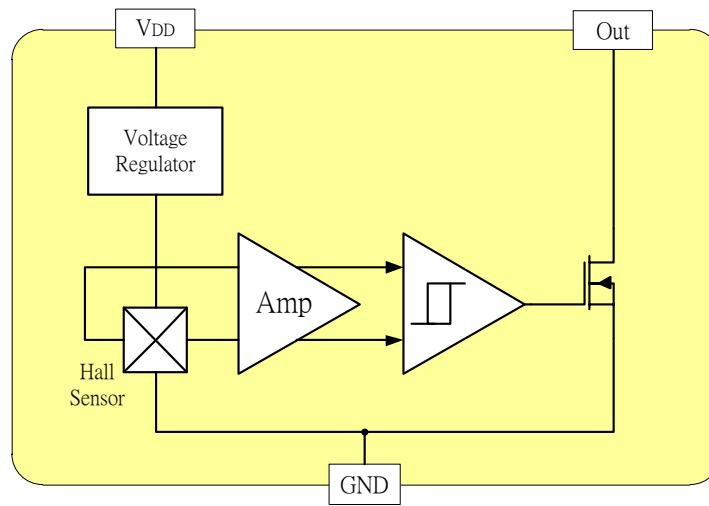

Absolute Maximum Ratings At ($T_a=25^\circ\text{C}$)

Characteristics		Values	Unit
Supply voltage, (V_{DD})		27	V
Output Voltage, (V_o)		27	V
Reverse Voltage, (V_{DD}) (V_{OUT})		-0.3	V
Magnetic flux density		Unlimited	Gauss
Output current, (I_{out})		50	mA
Operating Temperature Range, (T_a)	“E” version	-40 to +85	°C
	“K” version	-40 to +125	°C
Storage temperature range, (T_s)		-55 to +150	°C
Maximum Junction Temp, (T_j)		150	°C
Thermal Resistance	(θ_{ja}) UA / SO	206 / 543	°C/W
	(θ_{jc}) UA / SO	148 / 410	°C/W
Package Power Dissipation, (P_D) UA / SO		606 / 230	mW

Note: Do not apply reverse voltage to V_{DD} and V_{OUT} Pin, It may be caused for Miss function or damaged device.

Electrical Specifications

DC Operating Parameters : $T_A = +25^\circ\text{C}$, $V_{DD} = 12\text{V}$

Parameters	Test Conditions	Min	Typ	Max	Units
Supply Voltage, (V_{DD})	Operating	3.0		24.0	V
Supply Current, (I_{DD})	$B < B_{OP}$		2.5	5.0	mA
Output Saturation Voltage, (V_{Sat})	$I_{OUT} = 20\text{ mA}$, $B > B_{OP}$			500.0	mV
Output Leakage Current, (I_{off})	I_{OFF} $B < B_{RP}$, $V_{OUT} = 20\text{V}$			10.0	μA
Output Rise Time, (T_R)	$R_L = 1\text{k}\Omega$, $C_L = 20\text{pF}$		0.04		μs
Output Fall Time, (T_F)	$R_L = 1\text{k}\Omega$; $C_L = 20\text{pF}$		0.18		μs
Operate Point, (B_{OP})			175	250	Gauss
Release Point, (B_{RP})		95			Gauss
Hysteresis, (B_{HYS})			45		Gauss

Typical application circuit

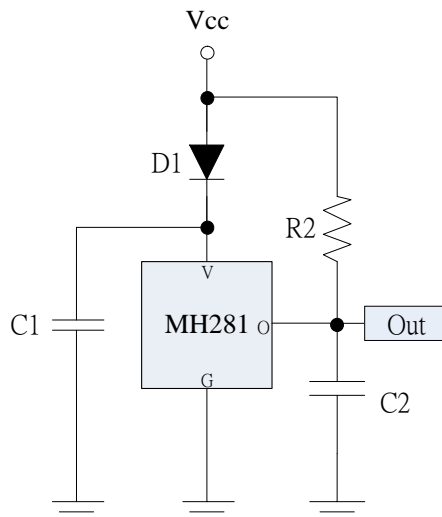

D1 : 1N4148 or 100Ω

C1 : 1000PF

C2 : 15PF

R2 : 10K Ω

Sensor Location, Package Dimension and Marking

MH281 Package

UA Package

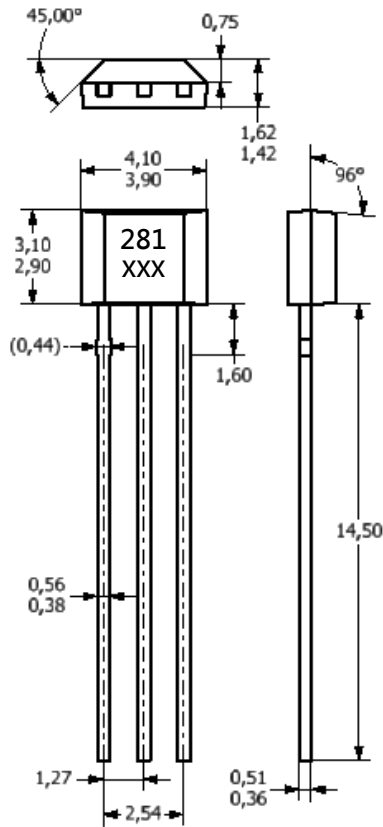

Package (SOT-23)
(Top View)

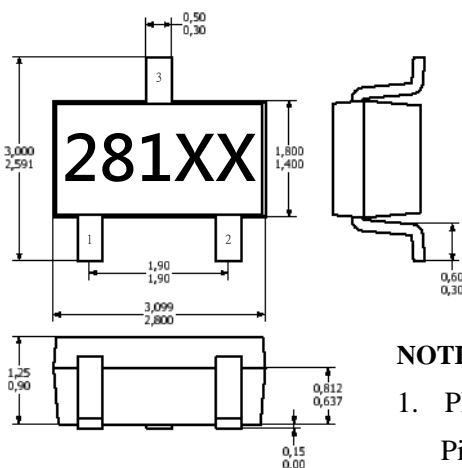

NOTES:

- PINOUT (See Top View at left :)
 - Pin 1 V_{CC}
 - Pin 2 Output
 - Pin 3 GND
- Controlling dimension: mm
- Lead thickness after solder plating will be 0.254mm maximum

Hall Chip location

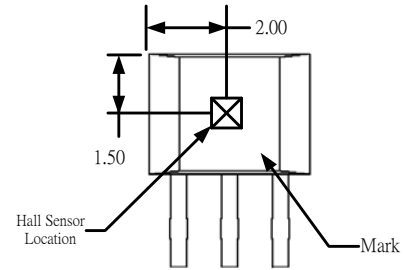

Output Pin Assignment (Top view)

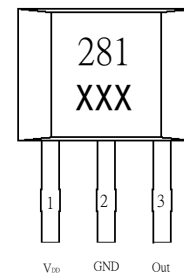

Hall Plate Chip Location (Bottom view)

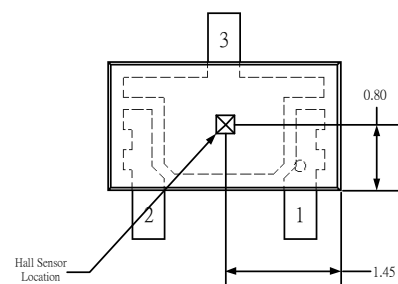



MH281 Specifications
Low Sensitivity Unipolar Hall Effect Switch
