

MH382 provides a one-chip solution for 3-wire fans with two unipolar coil windings. The chip contains the Hall-effect sensor, dynamic offset correction, power drivers and a pair of complementary open-drain outputs (DO, DOB). The output drivers pins are fully protected against switching transients.

While the magnetic flux density (B) is larger than operate point (Bop), DO will turn on (low), and meanwhile DOB will turn off (high). Each output is latched until B is lower than release point (Brp), and then DO, DOB transfer each state.

For DC fan application, sometimes need to test power reverse connection condition. Internal diode only protects chip-side but not for coil-side. If necessary, add one external diode to block the reverse current from coil-side

MH382 is rated for operation between the ambient temperatures -40°C and 125°C for the K temperature range. The package is available provided magnetically optimized solutions for most applications. Package VK is a four-lead ultra mini SIP for through-hole mounting. VF is a standard Sot-89, 5 pin packages at the E spec (-40°C and 85°C). also the Thermal shut-down function is integrated as well for better protection.

The package type is in a Halogen Free version has been verified by third party Lab.

Features and Benefits

- One Chip Hall sensor solution
- High sensitivity Hall sensor
- Locked rotor shutdown and auto-restart
- Power-efficient CMOS and power MOSFETS.
- Built-in Zener diodes protect outputs
- 4.5V to 30V operating voltage
- Peak currents up to 600mA
- Thermal shut-down

Applications

- Dual-coil Brush-less DC Motor
- Dual-coil Brush-less DC Fan
- Revolution Counting
- Speed Measurement

Function Diagram

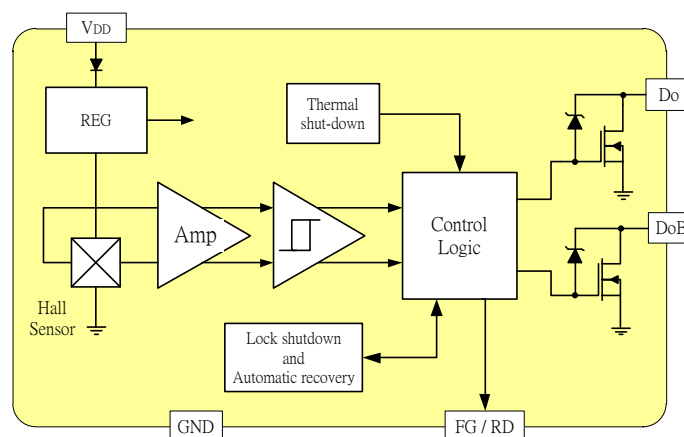

Ordering Information

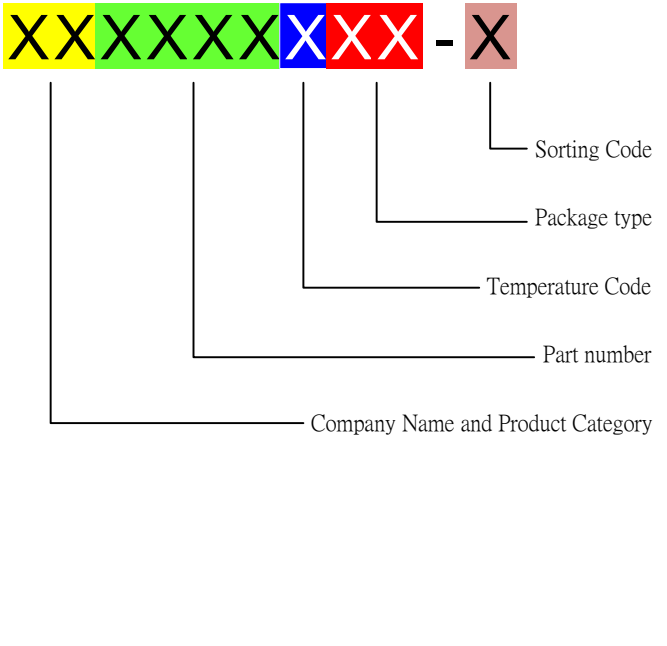
	<p>Company Name and Product Category MH:MST Hall Effect/MP:MST Power IC</p> <p>Part number 181,182,183,184,185,248,249,276,477,381,381F,381R,382..... If part # is just 3 digits, the fourth digit will be omitted.</p> <p>Temperature range E: 85 °C, I: 105 °C, K: 125 °C, L: 150 °C</p> <p>Package type UA:TO-92S,VK:TO-92S(4pin),VF:TO-92S(5pin),SO:SOT-23, SQ:QFN-3,ST:TSOT-23,SN:SOT-553,SF:SOT-89(5pin), SS:TSOT-26,SD:DFN-6</p> <p>Sorting <i>α, β</i>,Blank.....</p>
---	--

Part No.	Temperature Suffix	Package Type
MH382KVK	K(-40°C to + 125°C)	VK (4-pin TO-92S)
MH382EVK	E (-30°C to + 85°C)	VK (4-pin TO-92S)
MH382FKVF	K(-40°C to + 125°C)	VF (5-pin TO-92S)
MH382FEVF	E (-30°C to + 85°C)	VF (5-pin TO-92S)
MH382FESF	E (-30°C to + 85°C)	SF (5-pin SOT-89)
MH382RKVF	K(-40°C to + 125°C)	VF (5-pin TO-92S)
MH382REVF	E (-30°C to + 85°C)	VF (5-pin TO-92S)
MH382RESF	E (-30°C to + 85°C)	SF (5-pin SOT-89)

Absolute Maximum Ratings At ($T_a=25\text{ }^\circ\text{C}$)

Characteristics		Values	Unit
Supply voltage, (V_{DD})		32	V
Do, DoB Voltage, (V_z)		60	V
Reverse voltage, (V_{DD})		-32	V
Magnetic flux density		Unlimited	Gauss
Output “on” current	Average	300	mA
	Peak (Start Up)	600	
Operating Temperature Range, (T_a)	“E” version	-40 to +85	$^\circ\text{C}$
	“K” version	-40 to +125	$^\circ\text{C}$
Storage temperature range, (T_s)		-55 to +150	$^\circ\text{C}$
Maximum Junction Temp, (T_j)		150	$^\circ\text{C}$
Thermal Resistance	(θ_{JA}) VK / VF / SF	227 / 227 / 156	$^\circ\text{C}/\text{W}$
	(θ_{JC}) VK / VF / SF	49 / 49 / 34	$^\circ\text{C}/\text{W}$
Package Power Dissipation, (P_D) VK / VF / SF		550 / 550 / 800	mW

Note: Exceeding the absolute maximum ratings may cause permanent damage. Exposure to absolute maximum-rated conditions for extended periods may affect device reliability.

Electrical Specifications

DC Operating Parameters : $T_A=+25\text{ }^\circ\text{C}$, $V_{DD}=24\text{V}$

Parameters	Test Conditions	Min	Typ	Max	Units
Supply Voltage, (V_{DD})	Operating	4.5		30.0	V
Supply Current, (I_{DD})	Operating		3.0	6.0	mA
Output Leakage Current, (I_{off})	$V_{OUT}=60$		< 0.1	10	μA
Output On resistance, (R_{DSON})	$I_{OUT} = 300\text{ mA}$		2	3	Ω
FG/RD Output Voltage, (V_{OL})	$I_{OUT}=5\text{mA}$			0.5	V
FG/RD Pull-UP Voltage, (V_{OH})				30	V
FG/RD Output Current, (I_{FR})				50	mA
Locked Protection on, (T_{ON})		0.25	0.36	0.50	S
Locked Protection off, (T_{OFF})			2.1		S
Output Switching delay	“dead time” when both drivers are off		20		μS
Thermal shut-down Temp			145		$^\circ\text{C}$
Thermal shut-down Hysteresis			30		$^\circ\text{C}$
Electro-Static Discharge	HBM	4			KV
Operate Point, (B_{OP})		5	20	40	Gauss
Release Point, (B_{RP})		-40	-20	-5	Gauss
Hysteresis, (B_{HYS})			40		Gauss

Typical application circuit

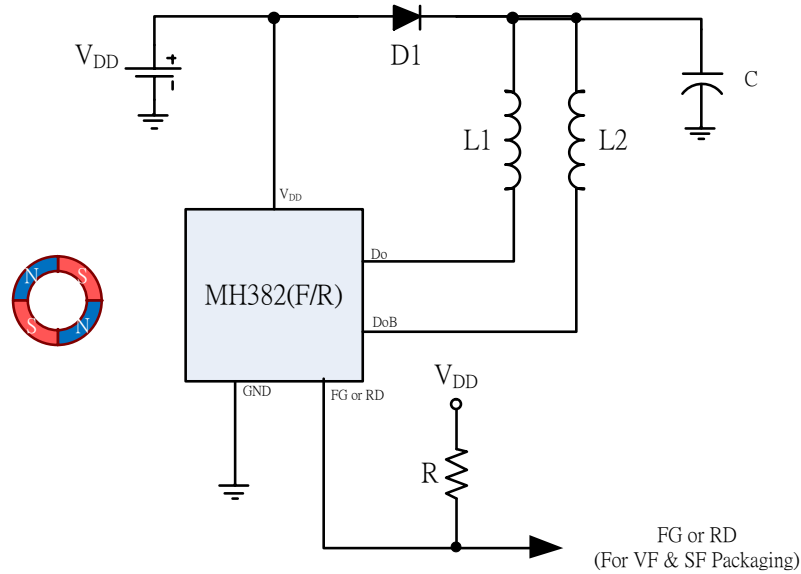

Sensor Location, package dimension and marking

MH382 Package

VK Package (To-92 4 pins)

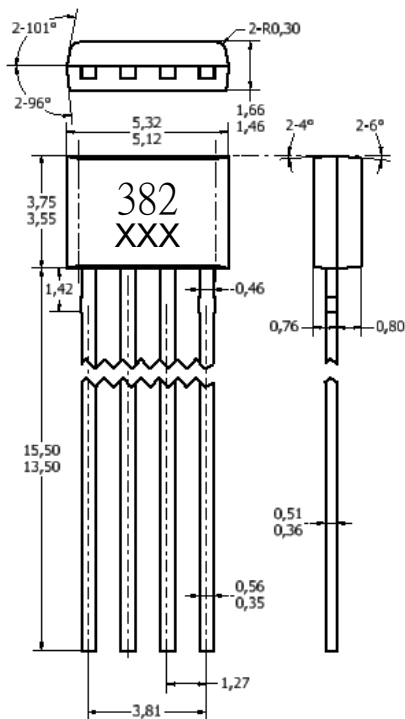

NOTES:

- 1).Controlling dimension: mm
- 2).Leads must be free of flash and plating voids
- 3).Do not bend leads within 1 mm of lead to package interface.
- 4).PINOUT:

Pin 1	V _{DD}
Pin 2	Do
Pin 3	DoB
Pin 4	GND

Hall Chip location

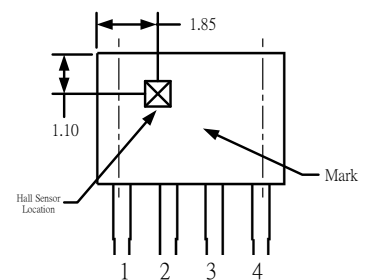

Output Pin Assignment

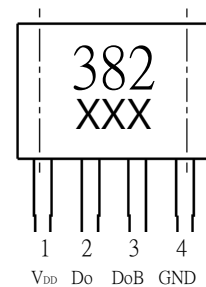

VF Package (To-92 5 pins)

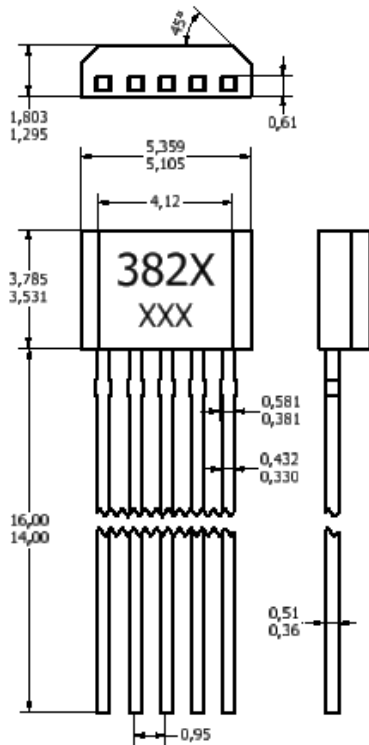

NOTES:

- 1).Controlling dimension: mm
- 2).Leads must be free of flash and plating voids
- 3).Do not bend leads within 1 mm of lead to package interface.

4).PINOUT:

Pin 1	V _{DD}
Pin 2	FG/RD
Pin 3	Do
Pin 4	DoB
Pin 5	GND

Hall Chip location

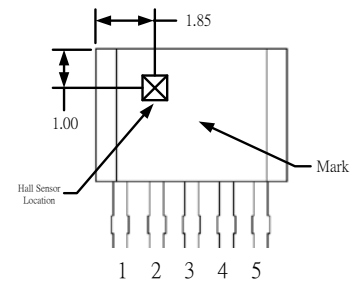

Output Pin Assignment

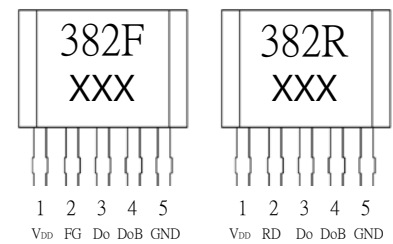

SF Package (SOT-89 5 pins)

(Bottom view)

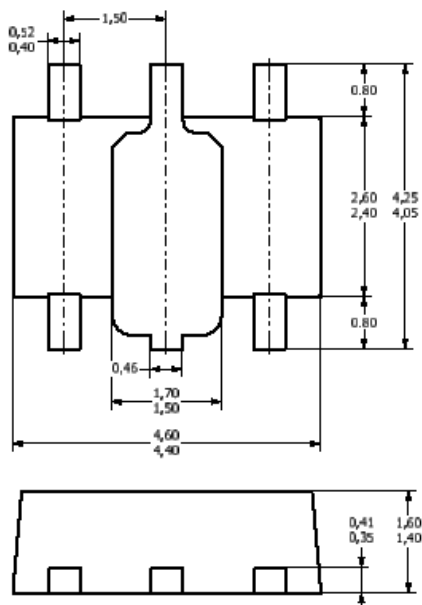

NOTES:

- 1).Controlling dimension: mm
- 2).Leads must be free of flash and plating voids
- 3).Do not bend leads within 1 mm of lead to package interface.

4).PINOUT:

Pin 1	V _{DD}
Pin 2	GND
Pin 3	Do
Pin 4	DoB
Pin 5	FG/RD

Hall Chip location

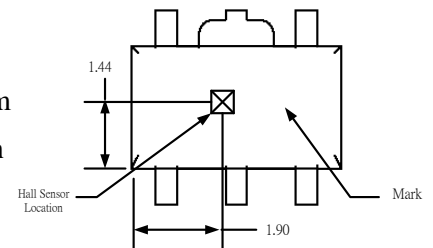

Output Pin Assignment

(Top view)

