

Features

- I/O non-isolation
- Efficiency up to 92%
- No heat sink required
- Single regulated output
- Short circuit protection
- Pin-out compatible with LM78 linear
- Low ripple and noise
- Wide temperature performance: -40 ~ to 85 ~

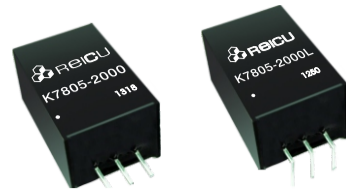

Description

The K78xx-2000 series are high efficiency switching regulators are suited to replace 78xx linear regulators and pin compatible. The high efficiency performance means it is no need heat sink. Used in industry control system, wireless network, microprocessor power application, telecom/datacom.

Model Selection Guide

| Order Code | Vin(V) | | Output | | Efficiency(%) (Typ) | |
|---------------|---------|---------|--------|--------|---------------------|----------|
| | Nominal | Range | Vo(V) | Io(mA) | Min(Vin) | Max(Vin) |
| K78X2-2000(L) | 12 | 4.75~18 | 1.8 | 2000 | 80 | 78 |
| K7802-2000(L) | | 4.75~18 | 2.5 | 2000 | 84 | 83 |
| K7803-2000(L) | | 4.75~18 | 3.3 | 2000 | 87 | 85 |
| K7805-2000(L) | | 7~18 | 5 | 2000 | 90 | 87 |
| K78X6-2000(L) | | 9~18 | 6.5 | 2000 | 92 | 90 |

*All the specifications typical at Ta=+25 resistive load, nominal input voltage and rated output current unless otherwise noted.

Output Characteristics

| Parameter | Condition | Min | Typ | Max | Units |
|-------------------------------|--------------------------|--------------------------------|-------|------|-------|
| Output voltage accuracy | 10% ~ 100% load | -- | ±1 | ±2 | % |
| Line regulation | At input voltage range | -- | ±0.15 | ±0.3 | % |
| Switching frequency | Full load, nominal input | -- | 330 | -- | KHz |
| Load regulation | 10% ~ 100% load | -- | ±0.3 | ±0.5 | % |
| Ripple and noise | BW=DC to 20MHz | -- | 50 | -- | mVp-p |
| Dynamic load response | 50% ~ 100% load | -- | 500 | -- | uS |
| Temperature coefficient(%/°C) | | -- | -- | 0.02 | %/°C |
| Quiescent current | | -- | 10 | -- | mA |
| Short circuit Protection | | Continuous, Automatic Recovery | | | |

General Characteristics

| Parameter | Condition | Min | Typ | Max | Units |
|-----------------------|-----------------------|-------------------|-----|------|---------|
| Operating Temperature | All output types | -40 | -- | +85 | °C |
| Storage | | -55 | -- | +125 | °C |
| Storage humidity | | -- | -- | +95 | % |
| Cooling | Free air convection | | | | |
| MTBF | 3.5 ~ 10 ⁶ | | | | K hours |
| Case material | | Plastic (UL94-V0) | | | |

Temperature Derating Graph Curve

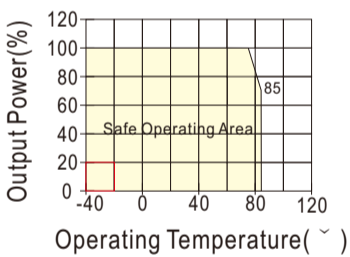

Efficiency VS Input Voltage Curve

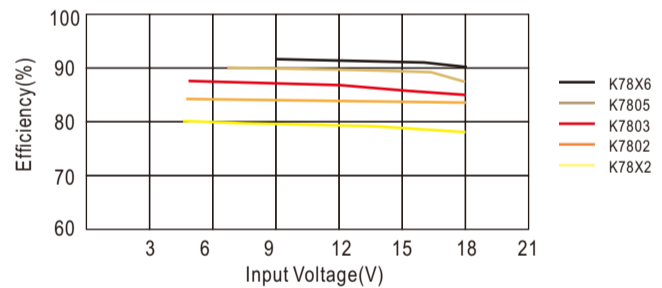

Application

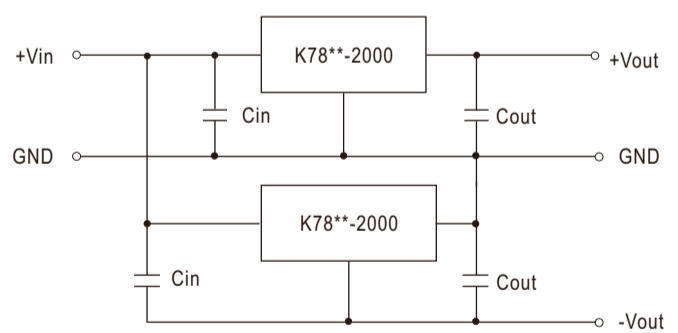
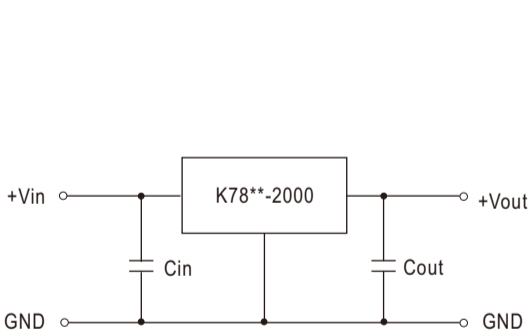

Note:

1. Cin and Cout are required and should be fitted close to the converter pins.
2. The capacitance of Cin and Cout are recommended 10-47uF capacitor. It can be increased properly if required, and tantalum or low ESR electrolytic capacitors may also suffice.

Mechanical Dimension & Pin Connections

