



MH182 Hall-Effect sensor is a temperature stable, stress-resistant latch. Superior high-temperature performance is made possible through a dynamic offset cancellation that utilizes chopper-stabilization. This method reduces the offset voltage normally caused by device over molding, temperature dependencies, and thermal stress.

MH182 includes the following on a single silicon chip: voltage regulator, Hall voltage generator, small-signal amplifier, chopper stabilization, Schmitt trigger, open-drain output. Advanced CMOS wafer fabrication processing is used to take advantage of low-voltage requirements, component matching, very low input-offset errors, and small component geometries.

This device requires the presence of both south and north polarity magnetic fields for operation. In the presence of a south polarity field of sufficient strength, the device output latches on, and only switches off when a north polarity field of sufficient strength is present.

MH182 is rated for operation between the ambient temperatures -40°C and 85°C for the E temperature range, and -40°C to 125°C for the K temperature range. The two package styles available provide magnetically optimized solutions for most applications. Package SO is an SOT-23, a miniature low-profile surface-mount package, while package UA is a three-lead ultra mini SIP for through-hole mounting.

The package type is in a Halogen Free version was verified by third party Lab.

Features and Benefits

- Chopper stabilized amplifier stage
- Optimized for BLDC motor applications
- New miniature package / thin, high reliability package
- Operation down to 3.0V
- 100% tested at 125°C for K.
- Custom sensitivity / Temperature selection are available.

Applications

- High temperature Fan motor
- 3 phase BLDC motor application
- Speed sensing
- Position sensing
- Current sensing
- Revolution counting
- Solid-State Switch
- Linear Position Detection
- Angular Position Detection
- Proximity Detection

Ordering Information

	<p>Company Name and Product Category MH:MST Hall Effect/MP:MST Power MOSFET</p> <p>Part number 181,182,183,184,185,248,249,276,477,381,381F,381R,382..... If part # is just 3 digits, the fourth digit will be omitted.</p> <p>Temperature range E: 85 °C, I: 105 °C, K: 125 °C, L: 150 °C</p> <p>Package type UA:TO-92S,VK:TO-92S(4pin),VF:TO-92S(5pin),SO:SOT-23, SQ:QFN-3,ST:TSOT-23,SN:SOT-553,SF:SOT-89(5pin)</p> <p>Sorting α, β, Blank.....</p>
<p>Sorting Code</p> <p>Package type</p> <p>Temperature Code</p> <p>Part number</p> <p>Company Name and Product Category</p>	

Part No.	Temperature Suffix	Package Type
MH182KUA	K (-40°C to + 125°C)	UA (TO-92S)
MH182KSO	K (-40°C to + 125°C)	SO (SOT-23)
MH182EUA	E (-40°C to + 85°C)	UA (TO-92S)
MH182ESO	E (-40°C to + 85°C)	SO (SOT-23)
MH182KUA- α	K (-40°C to + 125°C)	UA (TO-92S)
MH182KSO- α	K (-40°C to + 125°C)	SO (SOT-23)
MH182EUA- α	E (-40°C to + 85°C)	UA (TO-92S)
MH182ESO- α	E (-40°C to + 85°C)	SO (SOT-23)

KUA spec is using in industrial and automotive application. Special Hot Testing is utilized.

Functional Diagram

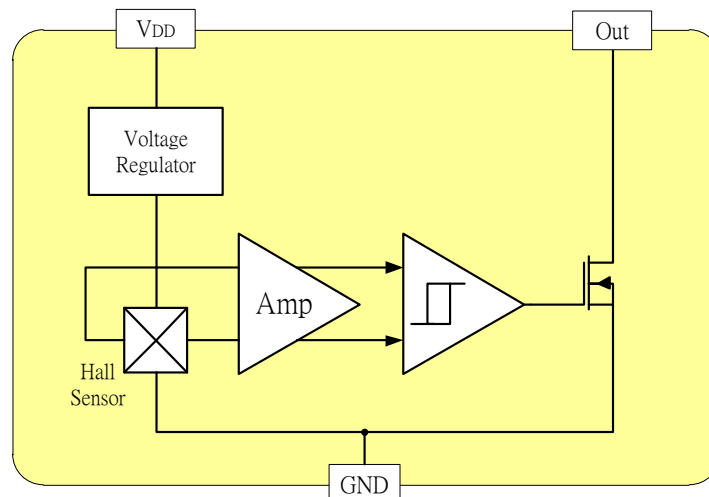

Absolute Maximum Ratings At ($T_a=25\text{ }^\circ\text{C}$)

Characteristics		Values	Unit
Supply voltage, (V_{DD})		26	V
Output Voltage, (V_{out})		26	V
Reverse voltage , (V_{DD}) (V_{OUT})		-0.3	V
Magnetic flux density		Unlimited	Gauss
Output current , (I_{out})		50	mA
Operating Temperature Range, (T_a)	“E” version	-40 to +85	$^\circ\text{C}$
	“K” version	-40 to +125	$^\circ\text{C}$
Storage temperature range, (T_s)		-65 to +150	$^\circ\text{C}$
Maximum Junction Temp, (T_j)		150	$^\circ\text{C}$
Thermal Resistance	(θ_{ja}) UA / SO	206 / 543	$^\circ\text{C}/\text{W}$
	(θ_{jc}) UA / SO	148 / 410	$^\circ\text{C}/\text{W}$
Package Power Dissipation, (P_D) UA / SO		606 / 230	mW

Note: Do not apply reverse voltage to V_{DD} and V_{OUT} Pin, It may be caused for Miss function or damaged device.

Electrical Specifications

DC Operating Parameters : $T_A=+25\text{ }^\circ\text{C}$, $V_{DD}=12\text{V}$

Parameters	Test Conditions	Min	Typ	Max	Units
Supply Voltage, (V_{DD})	Operating	3.0		24.0	V
Supply Current, (I_{DD})	$B < B_{OP}$			5.0	mA
Output Saturation Voltage, (V_{sat})	$I_{OUT} = 10\text{ mA}$, $B > B_{OP}$			400.0	mV
Output Leakage Current, (I_{off})	$I_{OFF} B < B_{RP}$, $V_{OUT} = 12\text{V}$			15.0	μA
Output Rise Time, (T_R)	$R_L=820\ \Omega$, $C_L=20\text{pF}$			0.45	μS
Output Fall Time, (T_F)	$R_L=820\ \Omega$; $C_L=20\text{pF}$			0.45	μS
Operate Point, (B_{OP})		10		60	Gauss
Release Point, (B_{RP})		-60		-10	Gauss
Hysteresis, (B_{HYS})			80		Gauss

Typical application circuit

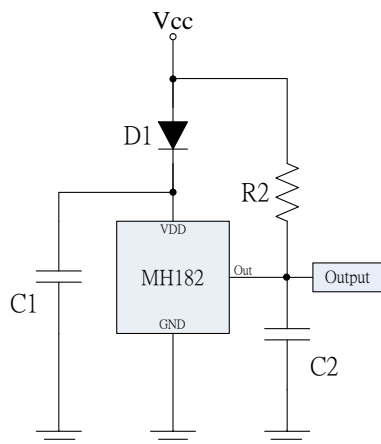

D1 : 1N4148 or 100 Ω

C1 : 1000PF

C2 : 15PF

R2 : 10K Ω

Sensor Location, Package Dimension and Marking

MH182 Package

UA Package

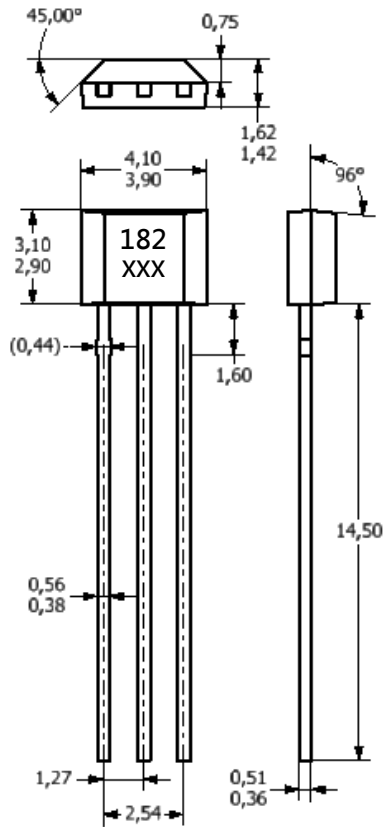

NOTES:

- 1).Controlling dimension: mm
- 2).Leads must be free of flash and plating voids
- 3).Do not bend leads within 1 mm of lead to package interface.
- 4).PINOUT:

Pin 1	V _{DD}
Pin 2	GND
Pin 3	Output

Hall Chip location

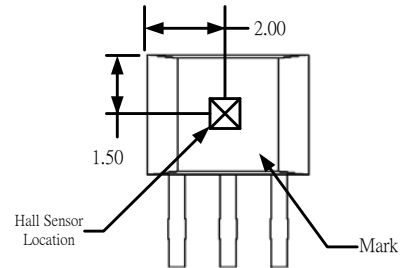

Output Pin Assignment

(Top view)

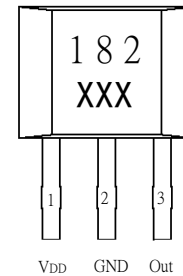

Package (SOT-23)

(Top View)

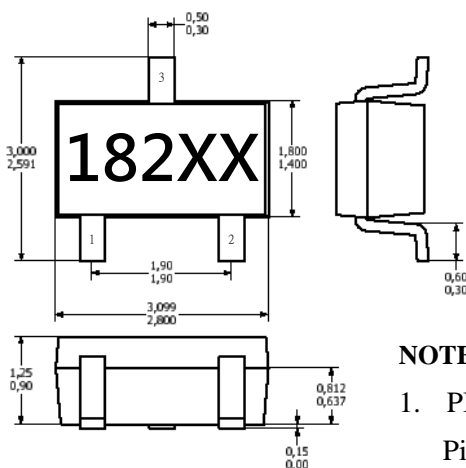

NOTES:

1. PINOUT (See Top View at left :)

Pin 1	V _{DD}
Pin 2	Output
Pin 3	GND
2. Controlling dimension: mm
3. Lead thickness after solder plating will be 0.254mm maximum

Hall Plate Chip Location

(Bottom view)

