

PART NO.
20367-001R

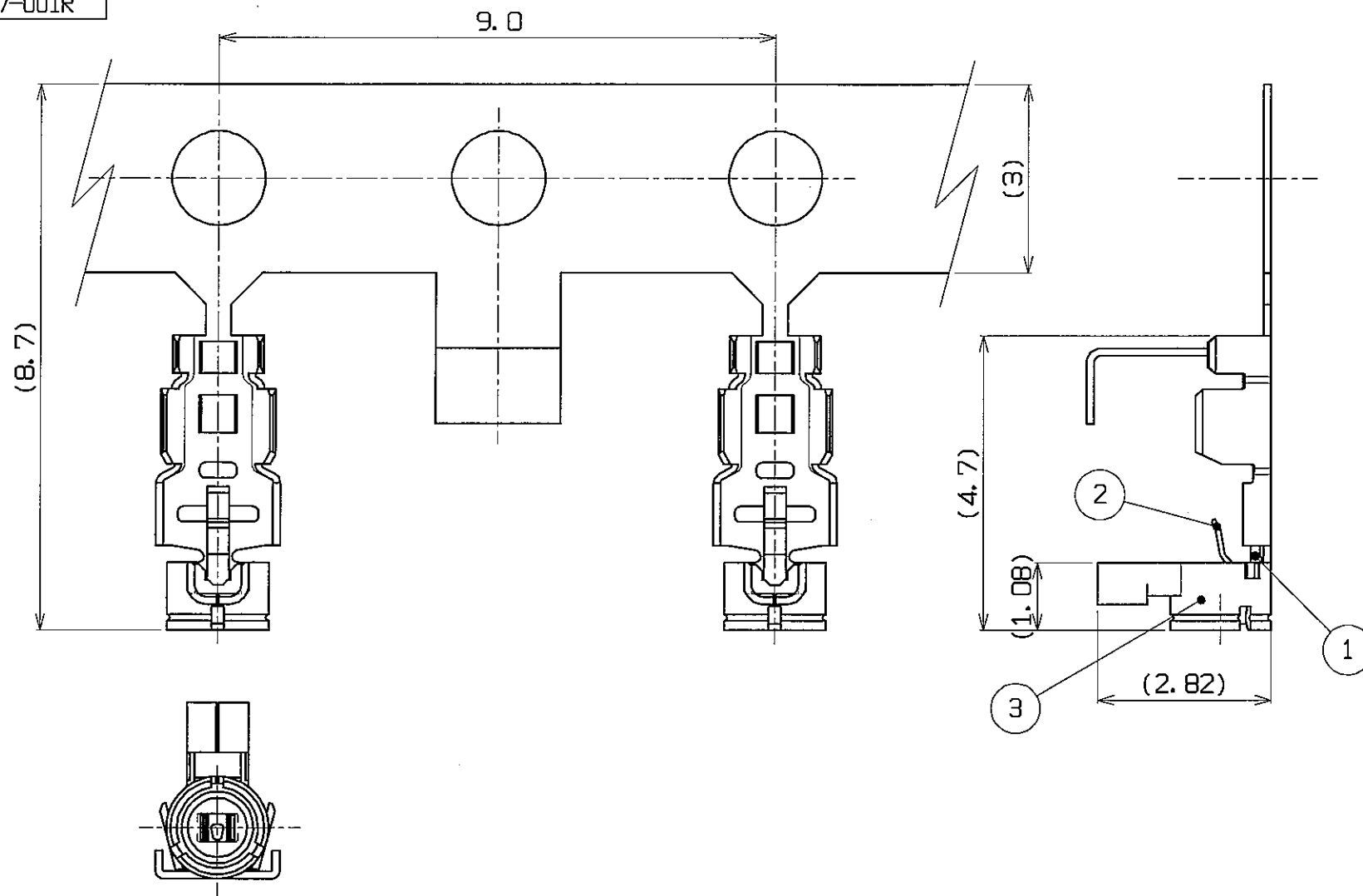

NOTES

1. MATERIAL
 ①HOUSING : LCP (Natural) UL94-V0
 ②CONTACT : Phosphor Bronze Au 0.1 μ mMIN. Over Ni 1.27 μ mMIN.
 ③GROUND CONTACT : Phosphor Bronze Au 0.05 μ mMIN. Over Ni 1.27 μ mMIN.

2. PACKING : REEL

3. APPLICABLE CABLE

3-1. DESCRIPTION

- Inner conductor : AWG#36(7/0.05)
 Silver plating annealed copper wire or silver plating tin-copper alloy.
 * Must not use solder coated inner conductor.
 Dielectric core: Fluoro-plastics, diameter 0.4(+0.04/-0.02)mm, nominal thickness 0.125m.
 Outer conductor: 8/5/0.05, nominal diameter 0.65mm, silver plating annealed copper wire.
 * Must not use solder coated outer conductor.
 Jacket : Fluoro-plastics, diameter 0.81(+0.04/-0.02)mm, nominal thickness 0.08mm.

3-2. REQUIREMENTS

- Characteristic impedance : 50(+2/-2)ohm by TDR method
 Nominal capacitance(Reference value) : 96pF/m
 Conductor resistance of inner conductor at 293K (Reference value): 1400 ohm/km
 Insulation resistance : 1000mega-ohm.km MIN.
 Dielectric withstance voltage : no breakdown at AC1000V for 1 minutes.

4. PERMISSIBLE LOAD OF CABLE AT MATING.

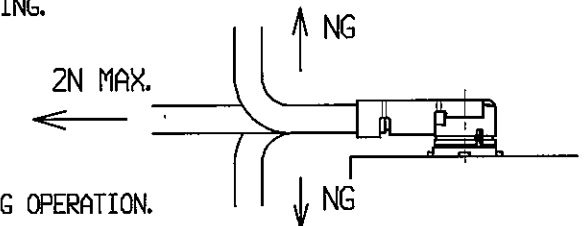

5. SUGGESTIONS FOR MATING & UNMATING OPERATION.

5-1. MATING

Please mate the connector straightly to vertical direction as much as possible, adjusting the mating axis of plug and receptacle.
 As excessive slant angle mating may break the connector, please don't do it.

5-2. UNMATING

5-2-1.

In case of unmating by pulling tool.
 Please use the pulling tool as the following drawing, and please pull plug to vertical direction as directly as possible.

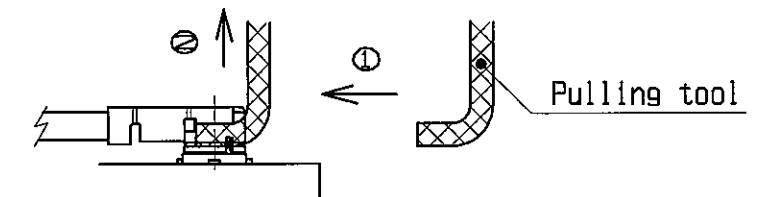

5-2-2.

In case of unmating directly by hand.
 Please catch the catching area of plug, and please pull plug to vertical direction as directly as possible.

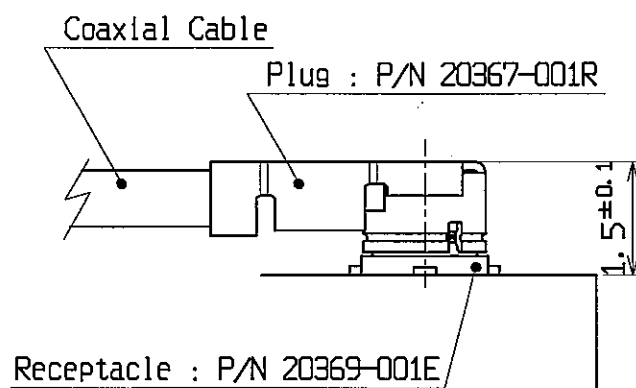
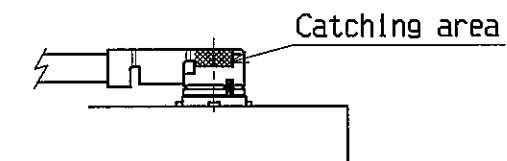

MATING

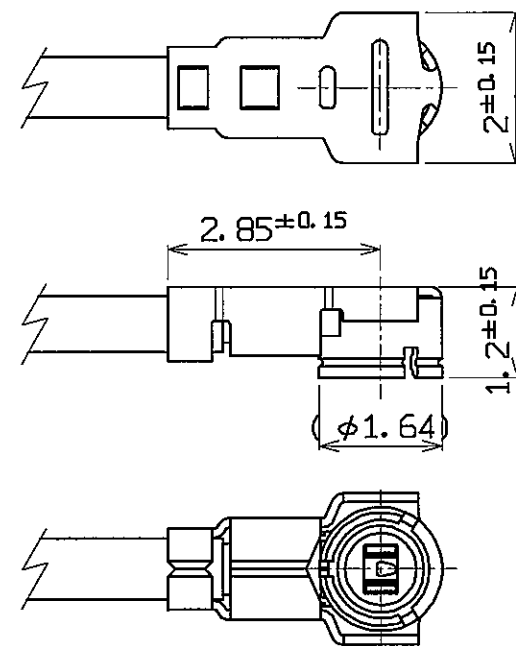

ASSEMBLY

GENERAL TOLERANCE	
6 MAX.	±0.2
6 OVER MAX. 30	±0.3
30 OVER MAX. 120	±0.5
ANGLE	±2°

REV	ECN	BY	DATE	APP	DESIGN'D BY	DATE
4	Z06046	TAK	JAN/31/06	TAK	T. TAKANO	Mar./01/04
3	Z05306	Y. H	JUL/01/05	E. K	T. HARADA	Mar./02/04
2	Z04411	TOM	NOV/22/04	E. K	K. KATABUCHI	Mar./02/04
1	Z04355	TOM	OCT/13/04	T. H		
0	Z04066	TOM	MAR/01/04			
REV. RECORD					CUSTOMER COPY	PROJECTION
SERIES No.					10/1	mm

I-PEX Interconnect and Packaging Electronics TOKYO, JAPAN

TITLE	SCALE	UNIT	DWG. No.	SHEET	REV.
MHFIII Connector Plug	10/1	mm	20367	1/2	4

Part No.	20367-001R	
Applicable cable nominal dimension	<p>※ NOTE-1</p>	
Braided shield of Outer conductor 外部導体の編組	Single / 1重編組	
P/N of semi auto termination machine	90283-008 Semi-auto	
Crimp Height	<p>※ NOTE-2</p>	<p>※ NOTE-2</p>
	CH-1 (Inner conductor part) 0.89 ~ 0.93	CH-2 (Jacket part) 0.80 ~ 0.85

NOTES

1. 中心導体、外部導体への半田コーティングは不可。
Must not use solder coated inner conductor and outer conductor.
2. ポイントマイクロメータを使用。
Use for point micrometer.

DESIGN' D BY	DATE	 Interconnect and Packaging Electronics TOKYO, JAPAN	TITLE			
CHK' D BY	DATE		MHF III Connector Plug			
APP' D BY	DATE		SCALE	UNIT	DWG. No.	
CUSTOMER COPY	PROJECTION	10/1	mm	20367	SHEET	REV.
					2/2	4