

APPLITEC

SWISS TOOLING

2012 - 2014

TOP-LINE



1

CUT-LINE

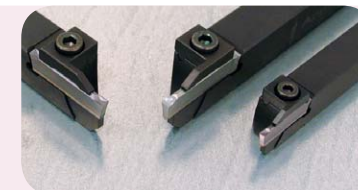

2

ISO-LINE



3

ECO-LINE

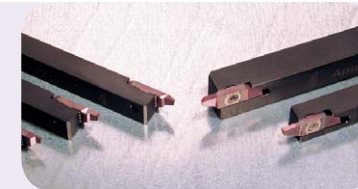

4

CIRCO-LINE



5

TOOLING-LINE



6

MODU-LINE



7

INDEX

8

TOP-LINE



i	paramètres et nuances Schnittwerte und Sorten data and grades	INFO		1.02 - 1.09	
		SERIES			
		L	R		
300	88°		310	320	1.10 - 1.13
	85°		330	340	1.14 - 1.17
700	pour machines à cames für kurvengesteuerte Maschinen for cam driven machines		710	720	1.18 - 1.23
			730	740	1.24 - 1.41
			750	760	1.42 - 1.67
			770	780	1.68 - 1.71
			7050	7060	1.72 - 1.75
		Burin avec plaquette large (max. 6 mm) Werkzeug mit breiter Wendeplatte (bis 6 mm) Tool with large insert (up to 6 mm)	W750	W760	1.76 - 1.77
SPECIAL 700	Porte-outils spéciaux pour machines Tornos Sonderhalter für Tornos Maschinen Special holders for Tornos machines		DECO / MICRO	1.78 - 1.83	
	Outils de tournage spécifiques au domaine de l'horlogerie Besondere Drehwerkzeuge für die Uhrindustrie Special turning tools for watch industry <i>new</i>		700sf+NOVIBRA	1.84 - 1.87	
	Porte-outils spéciaux pour usinage déporté Sonderhalter für versetzte Bearbeitung Special holders for shifted machining		740z / 760z	1.88	
	Pièces de rechange Ersatzteile Spare parts		SPARE PARTS	1.89	

700 SERIES

L'outil de référence pour le décolletage
Hochwertiges Wendeplattensystem für Langdrehautomaten
Top-class turning tools for automatic lathes

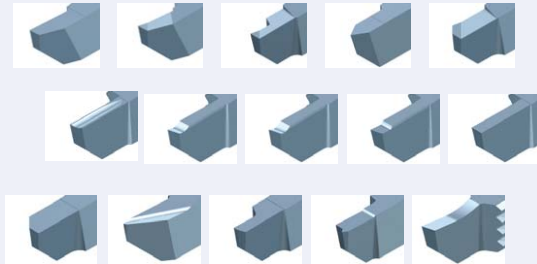

Système de serrage Applitec à denture décalée
Applitec-Spannsystem mit verschobener Verzahnung
Applitec clamping system with shifted teeth

100% rigid !

patented

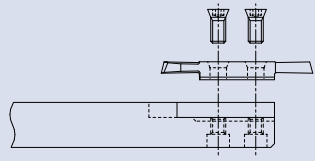

Serrage standard (A)
Standard Spannsystem (A)
Standard clamping system (A)

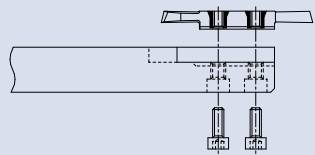
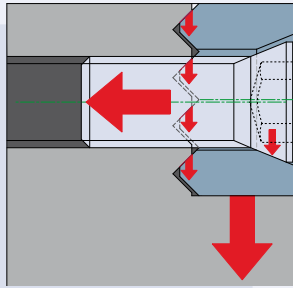

Serrage type B
Spannsystem Typ B
Clamping system type B

ajouter -B après le numéro d'article
-B nach der Artikelreferenz hinzufügen
add -B after the article number

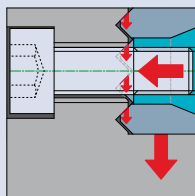

Changement de la plaquette possible dans la machine, sans démontage du porte-outil

WSP-Austauschmöglichkeit in der Maschine ohne Halterausbau

The insert can be changed in the machine, without removing the tool holder

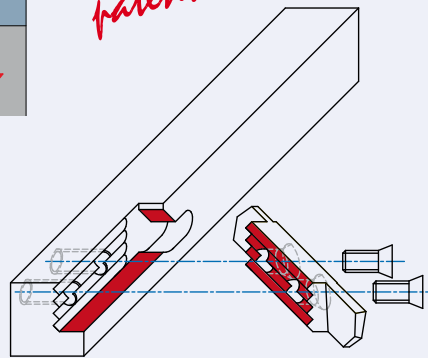

700 SERIES

ZX GEOMETRY

très bonne maîtrise du copeau pour matières difficiles

sehr gute Spankontrolle für schwierige Werkstoffe

very efficient chip control for difficult materials

multitude de géométries possibles
mehrere mögliche Spangeometrien
many different cutting geometries are possible

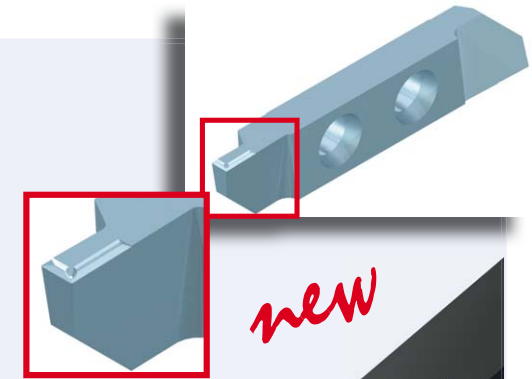

300 SERIES



R min. = 0
R

3 contact points

rigid clamping system

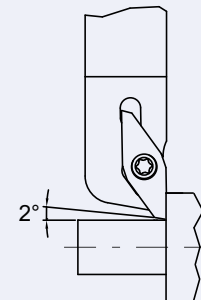

“wiper effect”

pour un meilleur état de surface
für eine bessere Oberflächengüte
for a better surface finish

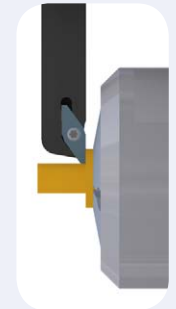

Nuances micro-grain universelles tenaces
 Universal zähe Feinkornsorten
 Universal tough micro-grain grades

N (μK20) non revêtu unbeschichtet uncoated	TiN μK20 + revêtement PVD μK20 + PVD Beschichtung μK20 + PVD coating	TiAlN μK20 + revêtement PVD μK20 + PVD Beschichtung μK20 + PVD coating
nuance micro-grain tenace supporte les coupes interrompues et autres conditions d'usinage défavorables	nuance pour l'usinage des matières peu résistantes qui créent des arêtes rapportées très faible coefficient de frottement à éviter pour l'usinage du titane	excellente nuance universelle 1er choix pour l'usinage des aciers, aciers inoxydables et alliages de titane très bonne résistance à la température
zähe Feinkornsorte für unterbrochene Schnitte und andere ungünstige Bearbeitungsbedingungen geeignet	Sorte für die Bearbeitung von weichen Werkstoffen mit Tendenz zur Bildung von Aufbauschneiden sehr geringer Reibwert für die Bearbeitung von Titan nicht geeignet	beste Universalsorte für die Bearbeitung von Stahl, rostfreiem Stahl und Titanlegierungen bestens geeignet sehr gute Warmfestigkeit
tough micro-grain grade suitable for interrupted cut and other unfavourable machining conditions	grade for the machining of low resistance materials which causes edge build-up very low friction ratio not suitable for titanium machining	best universal grade first choice for steel, stainless steel and titanium alloys machining very good heat resistance

Nuances micro-grain à dureté élevée
 Verschleißfeste Feinkornsorten
 Wear resistant micro-grain grades

HN (μK10) non revêtu unbeschichtet uncoated	HTiN μK10 + revêtement PVD μK10 + PVD Beschichtung μK10 + PVD coating	HTA μK10 + revêtement PVD μK10 + PVD Beschichtung μK10 + PVD coating
nuance micro-grain très résistante à l'usure recommandé pour l'usinage du titane faiblement allié déconseillé en cas de coupe interrompue et autres conditions d'usinage défavorables	nuance pour l'usinage en finition des matières peu résistantes qui créent des arêtes rapportées très faible coefficient de frottement à éviter pour l'usinage du titane	nuance très résistante à l'usure pour l'usinage en finition dans des conditions favorables des aciers, aciers inoxydables et alliages de titane
verschleißfeste Feinkornsorte empfehlenswert für die Bearbeitung von niedrig legiertem Titan für unterbrochene Schnitte und andere ungünstige Bearbeitungsbedingungen nicht geeignet	Sorte für die Feinbearbeitung von weichen Werkstoffen mit Tendenz zur Bildung von Aufbauschneiden sehr geringer Reibwert für die Bearbeitung von Titan nicht geeignet	sehr verschleißfeste Sorte für die Feinbearbeitung von Stahl, rostfreiem Stahl und Titanlegierungen bei guten Bearbeitungsbedingungen
wear resistant micro-grain grade suitable for the machining of low alloyed titanium not suitable for interrupted cut and other unfavourable machining conditions	grade for light machining of low resistance materials which causes edge build-up very low friction ratio not suitable for titanium machining	very wear resistant grade for light machining of steel, stainless steel and titanium alloys under favourable machining conditions

Géométries de coupe : conseils d'utilisation
 Spanformgeometrien : Anwendungsempfehlungen
 Cutting geometries : application recommendations

Series 300										
Géométries de coupe Spanformgeometrien Cutting geometries	Acier de décolletage Automatenstahl Free-cutting steel	Acier Stahl Steel	Acier inoxydable Rostfreistahl Stainless steel	Aluminium	Titane Titan Titanium	Laiton, bronze Messing, Bronze Brass, bronze	Cuivre Kupfer Copper	1er choix 1ste Wahl 1st choice	recommandé (voir remarques ci-dessous) empfohlen (siehe weitere Bemerkungen) recommended (see remarks here under)	pour pièces fragiles de très petits diamètres für empfindliche und sehr kleine Werkstücke for fragile and very small workpieces
3_7	Orange	Orange	Orange	Orange	Orange		Orange			géométrie universelle, très bonne maîtrise du copeau allgemeine Geometrie, sehr gute Spankontrolle all-round insert with efficient chip control
3_8	Ø	Ø	Ø			Orange				géométrie plate classique Standard flache Geometrie standard flat geometry
3_8 vs	Orange		Orange	Ø	Ø		Ø			brise-copeau pour usinage léger en finition Spanbrecher für leichte Schlichtbearbeitung chip-breaker for light finishing operation
3_8 vx			Orange	Orange	Orange		Orange			très bonne maîtrise du copeau sehr gute Spankontrolle very efficient chip control
3_8 x	Orange	Orange	Orange	Orange	Orange		Orange			coupe positive traditionnelle Standard positive Geometrie standard positive geometry
3_9	Orange	Orange	Orange							témoin plat sur la coupe pour réduire les vibrations Vibrationsreduzierung durch eine Flachfase an der Schneidkante vibration reduction through flat ended cutting edge
3_7 EN	Orange	Orange	Orange							arête renforcée (augmente l'effort de coupe) verstärkte Schneidkante (Schneidkraftehöhung) reinforced cutting edge (increases cutting force)

Géométries de coupe : conseils d'utilisation
Spanformgeometrien : Anwendungsempfehlungen
Cutting geometries : application recommendations

Series 700 tronçonnage - abstechen - parting off

Géométries de coupe Spanformgeometrien Cutting geometries		Matériaux								Notes
		Acier de décolletage Automatenstahl Free-cutting steel	Acier Stahl Steel	Acier inoxydable Rostfreistahl Stainless steel	Aluminium	Titane Titan Titanium	Laiton, bronze Messing, Bronze Brass, bronze	Cuivre Kupfer Copper	Ø	
	0°	1er choix	Ø	Ø	Ø	Ø	Ø	Ø	permet un réaffûtage aisé erlaubt einfaches Nachschleifen allows easy regrinding	
	x4°	recommandé	recommandé	recommandé	Ø	Ø		Ø	réduit l'effort de coupe, réaffûtable reduziert Schneidkräfte, nachschleifbar decreases cutting force, allows regrinding	
	xf	recommandé	recommandé	recommandé				recommandé	pour matières difficiles (pointe renforcée) für schwierige Werkstoffe (verstärkte Spitze) for difficult materials (reinforced point)	
	x12°			recommandé	recommandé	recommandé		recommandé	très bonne maîtrise du copeau sehr gute Spankontrolle very efficient chip control	
	x25°			recommandé	recommandé	recommandé		recommandé	pour matières collantes faisant de très longs copeaux für klebrige Werkstoffe mit sehr langen Spänen for long chipping sticky materials	
	u	recommandé	recommandé	recommandé					pour resserrer le copeau, réaffûtage aisé für Spanverschmälerung, einfaches Nachschleifen to narrow the chips, easy regrinding	

Géométries de coupe : conseils d'utilisation
Spanformgeometrien : Anwendungsempfehlungen
Cutting geometries : application recommendations

Series 700 tournage - Drehen - turning

Géométries de coupe Spanformgeometrien Cutting geometries		Matériaux								Notes
		Acier de décolletage Automatenstahl Free-cutting steel	Acier Stahl Steel	Acier inoxydable Rostfreistahl Stainless steel	Aluminium	Titane Titan Titanium	Laiton, bronze Messing, Bronze Brass, bronze	Cuivre Kupfer Copper	Ø	
	0°	1er choix	Ø	Ø	Ø	Ø	Ø	Ø	permet un réaffûtage aisé erlaubt einfaches Nachschleifen allows easy regrinding	
	x	recommandé	recommandé	recommandé	recommandé	recommandé		recommandé	coupe positive traditionnelle Standard positive Geometrie standard positive geometry	
	vx8°	recommandé	recommandé	recommandé	recommandé	recommandé		recommandé	très bonne maîtrise du copeau sehr gute Spankontrolle very efficient chip control	
	vx15°	recommandé		recommandé	recommandé	recommandé		recommandé	très bonne maîtrise du copeau sehr gute Spankontrolle very efficient chip control	
	vs	recommandé		recommandé	Ø	Ø		Ø	brise-copeau pour usinage léger en finition Spanbrecher für leichte Schlichtbearbeitung chip-breaker for light finishing operation	
	zx	recommandé	recommandé	recommandé	>12% Si	recommandé		recommandé	très bonne maîtrise du copeau sehr gute Spankontrolle very efficient chip control	

Paramètres de coupe indicatifs
Empfohlene Schnittwerte
Standard machining data

Matière Werkstoff Material	Tournage Drehen Turning			Tronçonnage Abstechen Cut off		
	Vc (mm/min)	Prof. de passe Schnitttiefe Depth of cut (mm)	Avance Vorschub Feed (mm/U)	Vc (mm/min)	Largeur de coupe Abstechbreite Cutting width (mm)	Avance Vorschub Feed (mm/U)
Acier de décolletage Automatenstahl Free-cutting steel	120-200	0.05-1.0 1.0-4.0	0.01-0.15 0.05-0.25	80- 150	0.50-1.50 1.50-3.50	0.01-0.08 0.03-0.15
Acier Stahl Steel < 600 N/mm ²	80-160	0.05-1.0 1.0-4.0	0.01-0.15 0.05-0.25	70-120	0.50-1.50 1.50-3.50	0.01-0.06 0.03-0.12
Acier Stahl Steel < 800 N/mm ²	60-120	0.05-1.0 1.0-4.0	0.01-0.10 0.05-0.20	60-100	0.50-1.50 1.50-3.50	0.01-0.05 0.03-0.10
Acier Stahl Steel > 800 N/mm ²	50-100	0.05-1.0 1.0-3.0	0.01-0.08 0.05-0.15	40-80	0.50-1.50 1.50-3.50	0.01-0.04 0.03-0.08
Acier inoxydable Rostfreier Stahl Stainless steel	60-120	0.05-1.0 1.0-3.0	0.01-0.08 0.05-0.15	60-100	0.50-1.50 1.50-3.50	0.01-0.04 0.03-0.08
Aluminium Si < 12%	200-1000	0.05-1.0 1.0-4.0	0.01-0.20 0.05-0.40	180-400	0.50-1.50 1.50-3.50	0.01-0.10 0.03-0.20
Aluminium Si > 12%	180-800	0.05-1.0 1.0-4.0	0.01-0.20 0.05-0.40	150-300	0.50-1.50 1.50-3.50	0.01-0.10 0.03-0.20
Titane Titan Titanium	30-70	0.05-1.0 1.0-4.0	0.01-0.08 0.05-0.15	30-50	0.50-1.50 1.50-3.50	0.01-0.03 0.03-0.06
Cuivre, laiton, bronze Kupfer, Messing, Bronze Copper, brass, bronze	100-500	0.05-1.0 1.0-4.0	0.01-0.20 0.05-0.35	100-300	0.50-1.50 1.50-3.50	0.01-0.10 0.03-0.20

Indications pour premiers réglages
Hinweise für die erste Einrichtung
Indications for first setting

ébauche schruppen roughing	finition schlichten finishing
vitesse de coupe moyenne avance élevée	vitesse de coupe élevée avance faible
durchschnittliche Schnittgeschwindigkeit hoher Vorschub	hohe Schnittgeschwindigkeit niedriger Vorschub
average cutting speed high cutting feed	high cutting speed low cutting feed

Remarque importante
Wichtige Bemerkung
Important remark

En raison des limites de la machine, il n'est souvent pas possible d'atteindre les vitesses de coupe préconisées.

Les outils Applitec sont spécialement développés pour permettre de hautes performances, même dans des conditions de coupe défavorables.

Des applications non préconisées dans le tableau ci-contre peuvent également s'avérer efficaces.

Wegen begrenzter Maschinenleistung ist es oft nicht möglich, die vorgeschlagenen Schnittgeschwindigkeiten zu erreichen.

Applitec Werkzeuge sind besonders dazu entwickelt um sogar bei ungünstigen Schnittdaten leistungsfähig zu sein.

Die in der nebenstehender Tabelle nicht erwähnten Anwendungsfälle können sich auch effizient erweisen.

In many cases, it is impossible to reach the recommended cutting speed, due to the machine limits.

Applitec tools are especially designed to be efficient even in bad cutting conditions.

Applications not mentioned in the opposite table can also be efficient.

porte-outils
Halter
holders

type 310

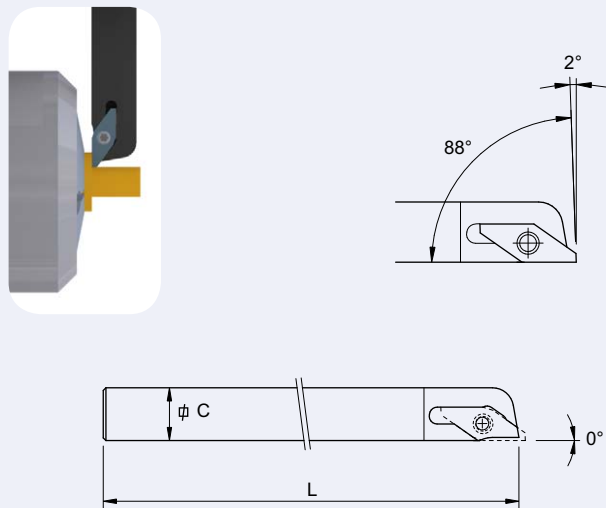

C	L	Art. N°
7 X 7	115	311
8 X 8	115	312
10 X 10	115	313
12 X 12	115	314
12 X 12	90	314-90
12 X 12	140	314-140
13 X 13	140	314-13
16 X 16	100	315
16 X 16	140	315-140
20 X 20	120	316

porte-outils
Halter
holders

type 320

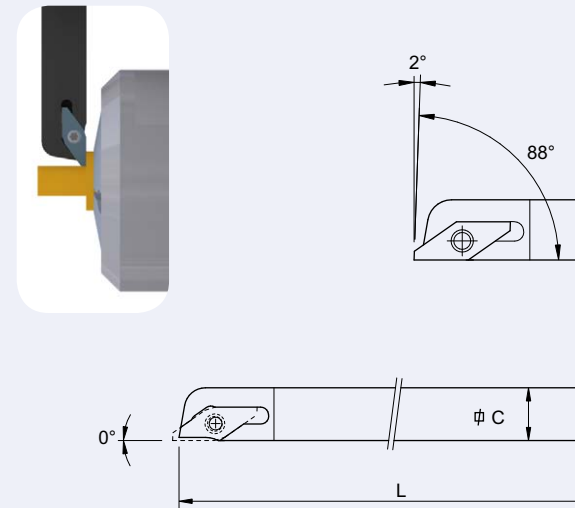

C	L	Art. N°
7 X 7	115	321
8 X 8	115	322
10 X 10	115	323
10 X 10	140	323-140
12 X 12	115	324
12 X 12	90	324-90
12 X 12	140	324-140
13 X 13	140	324-13
16 X 16	100	325
16 X 16	140	325-140
20 X 20	120	326

type 310-BC

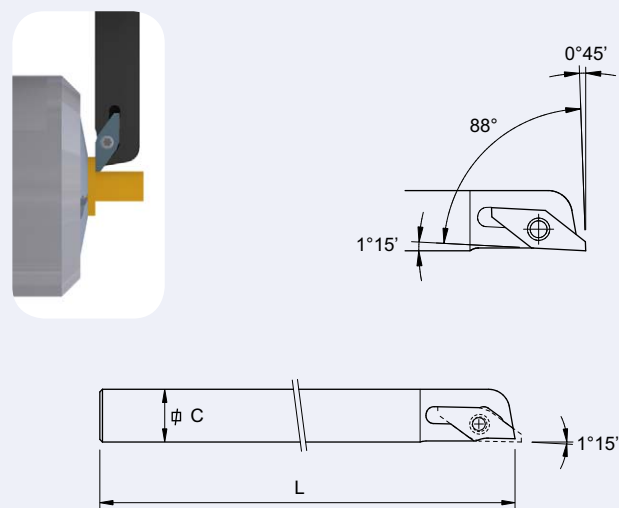

C	L	Art. N°
7 X 7	115	311-BC
8 X 8	115	312-BC
10 X 10	115	313-BC
12 X 12	115	314-BC
12 X 12	90	314-90-BC
12 X 12	140	314-140-BC
13 X 13	140	314-13-BC
16 X 16	100	315-BC
16 X 16	140	315-140-BC
20 X 20	120	316-BC

type 320-BC

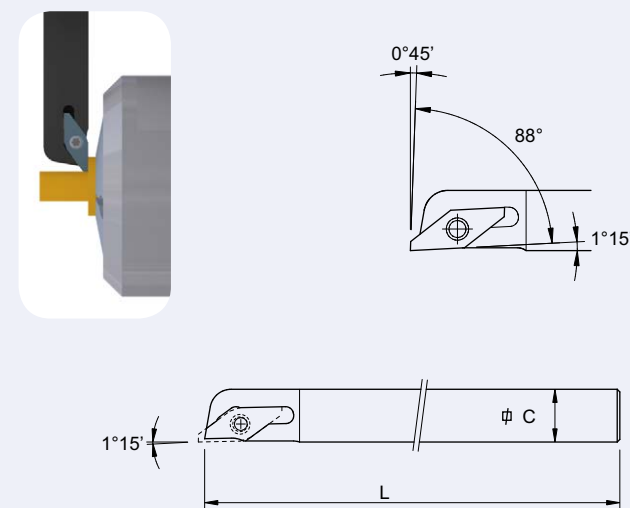

C	L	Art. N°
7 X 7	115	321-BC
8 X 8	115	322-BC
10 X 10	115	323-BC
10 X 10	140	323-140-BC
12 X 12	115	324-BC
12 X 12	90	324-90-BC
12 X 12	140	324-140-BC
13 X 13	140	324-13-BC
16 X 16	100	325-BC
16 X 16	140	325-140-BC
20 X 20	120	326-BC

tourneur avant
vorwärts drehen
front turning

88°

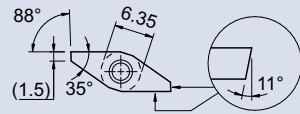

317

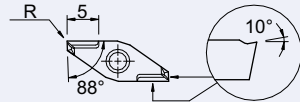

318

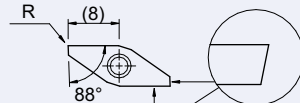

318VS

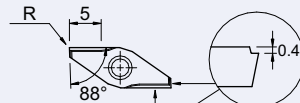

318VX

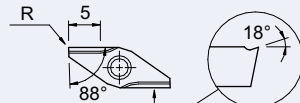

318X

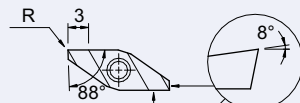

319

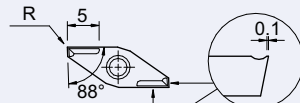

R	Art. N°	TIN TIALN N (μK20)	HTIN HTA HN (μK10)
0	317	■ ■ ■	■ ■ ■
0.03	317-R03	■ ■ ■	■ ■ ■
0.08	317-R08	■ ■ ■	■ ■ ■
0.1	317-R10	■ ■ ■	■ ■ ■
0.2	317-R20	■ ■ ■	■ ■ ■

0	318	■ ■ ■	■ ■ ■
0.1	318-R10	■ ■ ■	■ ■ ■
0.2	318-R20	■ ■ ■	■ ■ ■
0.4	318-R40	■ ■ ■	■ ■ ■

0	318VS	■ ■ ■	■ ■ ■
0.1	318VS-R10	■ ■ ■	■ ■ ■

0	318VX	■ ■ ■	■ ■ ■
0.05	318VX-R05	■ ■ ■	■ ■ ■

0	318X	■ ■ ■	■ ■ ■
0.1	318X-R10	■ ■ ■	■ ■ ■

0	319	■ ■ ■	■ ■ ■
0.1	319-R10	■ ■ ■	■ ■ ■
0.2	319-R20	■ ■ ■	■ ■ ■

■ = Disponible / Verfügbar / Available
□ = Avec délai de livraison / Mit Lieferfrist / Available with delivery time

tourneur avant
vorwärts drehen
front turning

88°

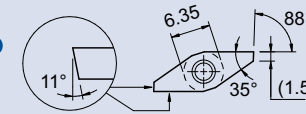

327

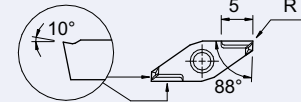

328

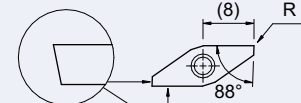

328VS

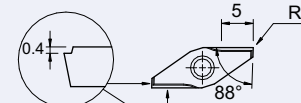

328VX

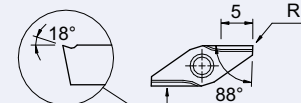

328X

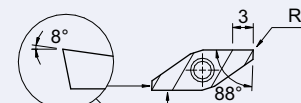

329

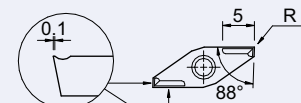

R	Art. N°	TIN TIALN N (μK20)	HTIN HTA HN (μK10)
0	327	■ ■ ■	■ ■ ■
0.03	327-R03	■ ■ ■	■ ■ ■
0.08	327-R08	■ ■ ■	■ ■ ■
0.1	327-R10	■ ■ ■	■ ■ ■
0.2	327-R20	■ ■ ■	■ ■ ■

0	328	■ ■ ■	■ ■ ■
0.1	328-R10	■ ■ ■	■ ■ ■
0.2	328-R20	■ ■ ■	■ ■ ■
0.4	328-R40	■ ■ ■	■ ■ ■

0	328VS	■ ■ ■	■ ■ ■
0.1	328VS-R10	■ ■ ■	■ ■ ■

0	328VX	■ ■ ■	■ ■ ■
0.05	328VX-R05	■ ■ ■	■ ■ ■

0	328X	■ ■ ■	■ ■ ■
0.1	328X-R10	■ ■ ■	■ ■ ■

0	329	■ ■ ■	■ ■ ■
0.1	329-R10	■ ■ ■	■ ■ ■
0.2	329-R20	■ ■ ■	■ ■ ■

■ = Disponible / Verfügbar / Available
□ = Avec délai de livraison / Mit Lieferfrist / Available with delivery time

porte-outils
Halter
holders

type 330

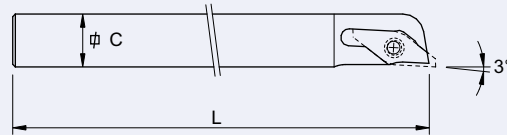
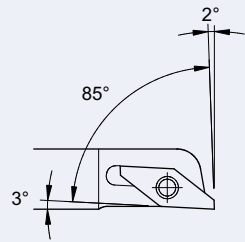
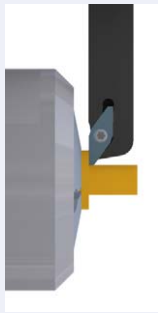

C	L	Art. N°
8 X 8	115	332
10 X 10	115	333
12 X 12	115	334
12 X 12	90	334-90
12 X 12	140	334-140
13 X 13	140	334-13
16 X 16	100	335
16 X 16	140	335-140
20 X 20	120	336

Plaquette avec arête de coupe renforcée par polissage
WSP mit verstärkter und polierter Schneidkante
Insert with reinforced and polished cutting edge

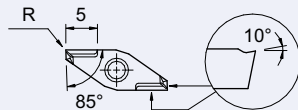

R	Art. N°	TIN	TIALN	N (μK20)
0	337-EN	■	■	■
0.08	337-EN-R08	■	■	■
0.1	337-EN-R10	■	■	■
0.2	337-EN-R20	■	■	■

337-EN

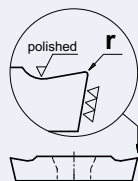

■ = Disponible / Verfügbar / Available
□ = Avec délai de livraison / Mit Lieferfrist / Available with delivery time

porte-outils
Halter
holders

type 340

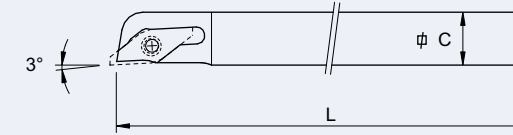
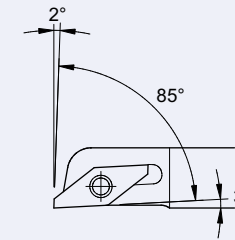
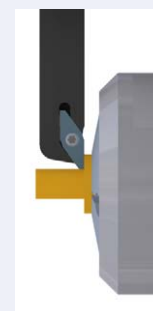

C	L	Art. N°
8 X 8	115	342
10 X 10	115	343
10 X 10	140	343-140
12 X 12	115	344
12 X 12	90	344-90
12 X 12	140	344-140
13 X 13	140	344-13
16 X 16	100	345
16 X 16	140	345-140
20 X 20	120	346

Plaquette avec arête de coupe renforcée par polissage
WSP mit verstärkter und polierter Schneidkante
Insert with reinforced and polished cutting edge

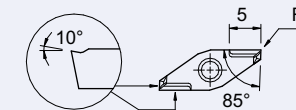

R	Art. N°	TIN	TIALN	N (μK20)
0	347-EN	■	■	■
0.08	347-EN-R08	■	■	■
0.1	347-EN-R10	■	■	■
0.2	347-EN-R20	■	■	■

347-EN

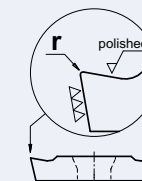

■ = Disponible / Verfügbar / Available
□ = Avec délai de livraison / Mit Lieferfrist / Available with delivery time

tourneur avant
vorwärts drehen
front turning

85°

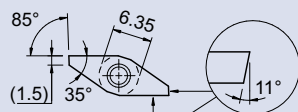

337

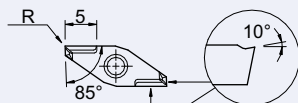

338

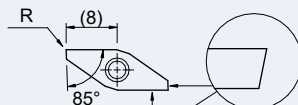

338VS

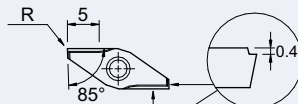

338VX

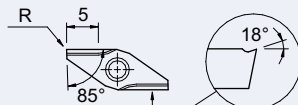

338X

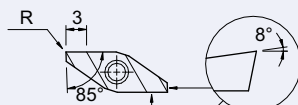

339

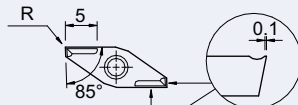

R	Art. N°	TIN	TIALN	N (μK20)	HTIN	HTA	HN (μK10)
0	337	■	■	■	■	■	■
0.03	337-R03	■	■	■	■	■	■
0.08	337-R08	■	■	■	■	■	■
0.1	337-R10	■	■	■	■	■	■
0.2	337-R20	■	■	■	■	■	■

0	338	■	■	■	■	■	■
0.1	338-R10	■	■	■	■	■	■
0.2	338-R20	■	■	■	■	■	■
0.4	338-R40	■	■	■	■	■	■

0	338VS	■	■	■	■	■	■
0.1	338VS-R10	■	■	■	■	■	■

0	338VX	■	■	■	■	■	■
0.05	338VX-R05	■	■	■	■	■	■

0	338X	■	■	■	■	■	■
0.1	338X-R10	■	■	■	■	■	■

0	339	■	■	■	■	■	■
0.1	339-R10	■	■	■	■	■	■
0.2	339-R20	■	■	■	■	■	■

■ = Disponible / Verfügbar / Available
□ = Avec délai de livraison / Mit Lieferfrist / Available with delivery time

tourneur avant
vorwärts drehen
front turning

85°

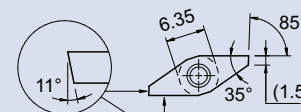

347

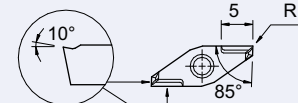

348

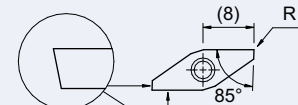

348VS

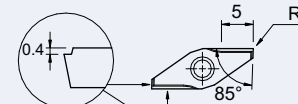

348VX

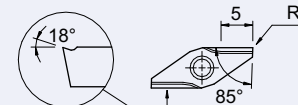

348X

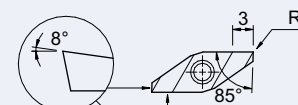

349

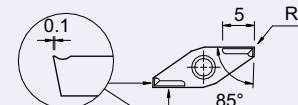

R	Art. N°	TIN	TIALN	N (μK20)	HTIN	HTA	HN (μK10)
0	347	■	■	■	■	■	■
0.03	347-R03	■	■	■	■	■	■
0.08	347-R08	■	■	■	■	■	■
0.1	347-R10	■	■	■	■	■	■
0.2	347-R20	■	■	■	■	■	■

0	348	■	■	■	■	■	■
0.1	348-R10	■	■	■	■	■	■
0.2	348-R20	■	■	■	■	■	■
0.4	348-R40	■	■	■	■	■	■

0	348VS	■	■	■	■	■	■
0.1	348VS-R10	■	■	■	■	■	■

0	348VX	■	■	■	■	■	■
0.05	348VX-R05	■	■	■	■	■	■

0	348X	■	■	■	■	■	■
0.1	348X-R10	■	■	■	■	■	■

0	349	■	■	■	■	■	■
0.1	349-R10	■	■	■	■	■	■
0.2	349-R20	■	■	■	■	■	■

■ = Disponible / Verfügbar / Available
□ = Avec délai de livraison / Mit Lieferfrist / Available with delivery time

Série spéciale pour machines à cames à gauche
 Sonderreihe für linksdrehende kurvengesteuerte Maschinen
 Special series for left hand turning cam driven machines

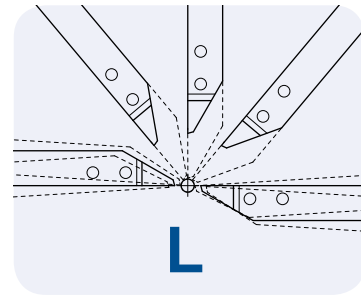
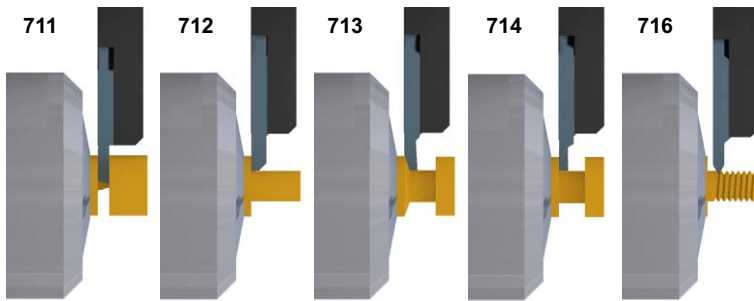

porte-outils Halter holders

710

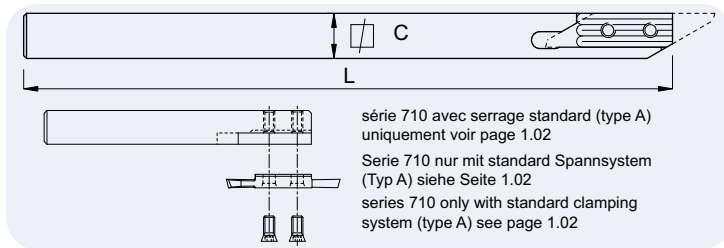

série 710 avec serrage standard (type A)
 uniquement voir page 1.02
 Serie 710 nur mit standard Spannsystem
 (Typ A) siehe Seite 1.02
 series 710 only with standard clamping
 system (type A) see page 1.02

C	L	Art. N°
6 X 6	115	710-6
7 X 7	115	710-7
8 X 8	115	710-8
10 X 10	115	710-10
12 X 12	130	710-12

plaquette ébauche VHM-Rohling blank insert

711-E

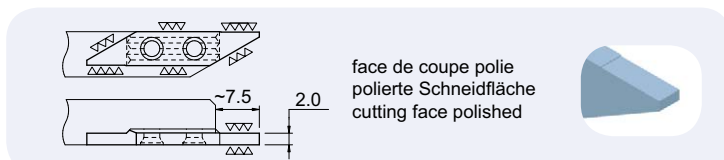

face de coupe polie
 polierte Schneidfläche
 cutting face polished

Art. N°	N (µK20)	HN (µK10)
711-EP	■	■

tronçonnage abstechen parting off

711

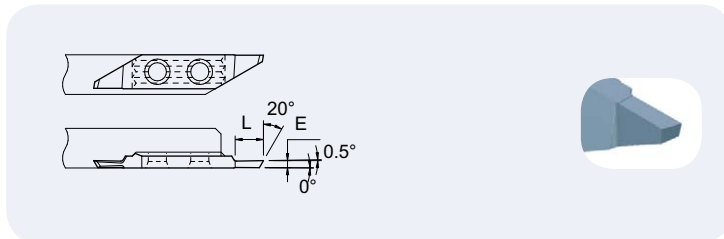

E	L	Art. N°	TIN	TiAlN	N (µK20)	HTIN	HTA	HN (µK10)
0.5	2	711-0.5	■	■	■	□	□	□
0.8	3	711-0.8	■	■	■	□	□	□
0.9	3	711-0.9	■	■	■	□	□	□
1.0	4	711-1.0	■	■	■	□	□	□
1.1	4	711-1.1	■	■	■	□	□	□
1.2	5	711-1.2	■	■	■	□	□	□
1.3	5	711-1.3	■	■	■	□	□	□
1.4	5	711-1.4	■	■	■	□	□	□
1.5	6.5	711-1.5	■	■	■	□	□	□
1.8	6.5	711-1.8	■	■	■	□	□	□
2.0	6.5	711-2.0	■	■	■	□	□	□

■ = Disponible / Verfügbar / Available
 □ = Avec délai de livraison / Mit Lieferfrist / Available with delivery time

Série spéciale pour machines à cames à droite
 Sonderreihe für rechtsdrehende kurvengesteuerte Maschinen
 Special series for right hand turning cam driven machines

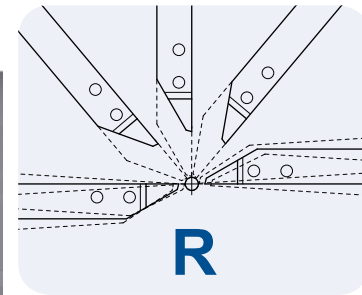
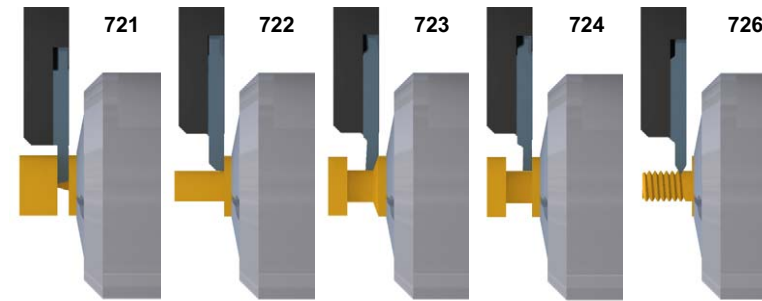

porte-outils Halter holders

720

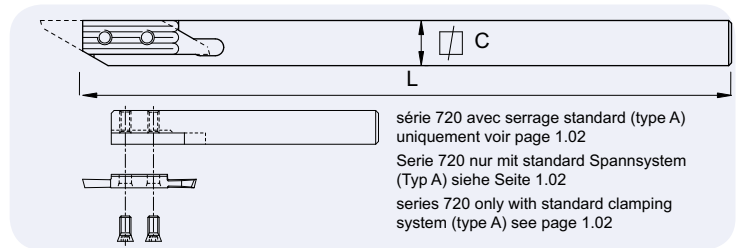

série 720 avec serrage standard (type A)
 uniquement voir page 1.02
 Serie 720 nur mit standard Spannsystem
 (Typ A) siehe Seite 1.02
 series 720 only with standard clamping
 system (type A) see page 1.02

C	L	Art. N°
7 X 7	115	720-7
8 X 8	115	720-8
10 X 10	115	720-10
12 X 12	130	720-12

plaquette ébauche VHM-Rohling blank insert

721-E

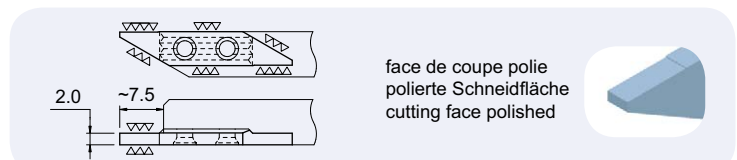

face de coupe polie
 polierte Schneidfläche
 cutting face polished

Art. N°	N (µK20)	HN (µK10)
721-EP	■	■

tronçonnage abstechen parting off

721

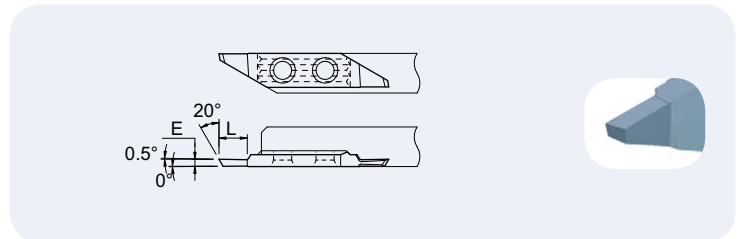

E	L	Art. N°	TIN	TiAlN	N (µK20)	HTIN	HTA	HN (µK10)
0.8	3	721-0.8	■	■	■	□	□	□
1.0	4	721-1.0	■	■	■	□	□	□
1.2	5	721-1.2	■	■	■	□	□	□
1.5	6.5	721-1.5	■	■	■	□	□	□
1.8	6.5	721-1.8	■	■	■	□	□	□
2.0	6.5	721-2.0	■	■	■	□	□	□

■ = Disponible / Verfügbar / Available
 □ = Avec délai de livraison / Mit Lieferfrist / Available with delivery time



tourneur avant
vorwärts drehen
front turning

712

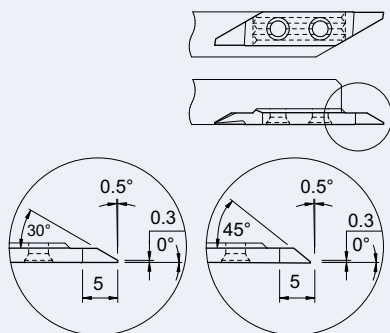

30°

45°

60°



Art. N°	TIN	TIALN	N (µK20)	HTIN	HTA	HN (µK10)
712-30	■	■	■	□	■	■
712-45	■	■	■	■	■	■
712-60	■	■	■	□	■	■



tourneur arrière
rückwärts drehen
back turning

713

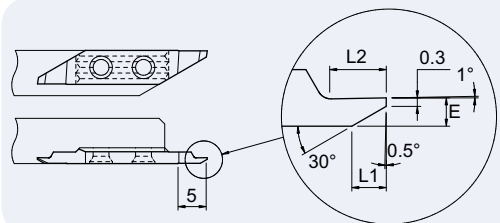

E	~L1	L2	Art. N°	TIN	TIALN	N (µK20)	HTIN	HTA	HN (µK10)
0.8	0.85	1.6	713-30-0.8	■	■	■	□	□	□
0.9	1.05	1.6	713-30-0.9	■	■	■	□	□	□
1.0	1.2	2.0	713-30-1.0	■	■	■	□	□	□
1.1	1.4	2.0	713-30-1.1	■	■	■	□	□	□
1.2	1.55	2.5	713-30-1.2	■	■	■	□	□	□
1.3	1.7	2.5	713-30-1.3	■	■	■	□	□	□
1.4	1.9	3.0	713-30-1.4	■	■	■	□	□	□
1.5	2.1	3.0	713-30-1.5	■	■	■	■	■	■
1.8	2.6	4.0	713-30-1.8	■	■	■	□	□	□
2.0	3.0	4.0	713-30-2.0	■	■	■	■	■	■

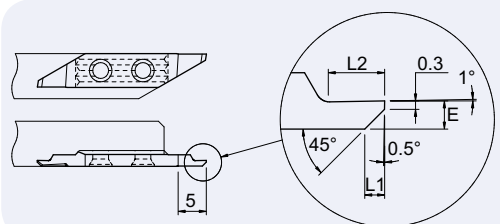

0.8	0.5	1.6	713-45-0.8	■	■	■	□	□	□
0.9	0.6	1.6	713-45-0.9	■	■	■	□	□	□
1.0	0.7	2.0	713-45-1.0	■	■	■	■	■	■
1.1	0.8	2.0	713-45-1.1	■	■	■	□	□	□
1.2	0.9	2.5	713-45-1.2	■	■	■	□	□	□
1.3	1.0	2.5	713-45-1.3	■	■	■	□	□	□
1.4	1.1	3.0	713-45-1.4	■	■	■	□	□	□
1.5	1.2	3.0	713-45-1.5	■	■	■	■	■	■
1.8	1.5	4.0	713-45-1.8	■	■	■	□	□	□
2.0	1.7	4.0	713-45-2.0	■	■	■	■	■	■

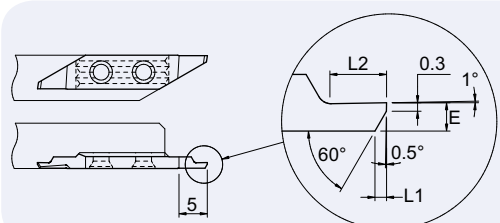

0.8	0.3	1.6	713-60-0.8	■	■	■	□	□	□
0.9	0.35	1.6	713-60-0.9	■	■	■	□	□	□
1.0	0.4	2.0	713-60-1.0	■	■	■	□	□	□
1.1	0.45	2.0	713-60-1.1	■	■	■	□	□	□
1.2	0.5	2.5	713-60-1.2	■	■	■	□	□	□
1.3	0.6	2.5	713-60-1.3	■	■	■	□	□	□
1.4	0.65	3.0	713-60-1.4	■	■	■	□	□	□
1.5	0.7	3.0	713-60-1.5	■	■	■	□	□	□
1.8	0.85	4.0	713-60-1.8	■	■	■	□	□	□
2.0	1.0	4.0	713-60-2.0	■	■	■	□	□	□

■ = Disponible / Verfügbar / Available
□ = Avec délai de livraison / Mit Lieferfrist / Available with delivery time

722

tourneur avant
vorwärts drehen
front turning

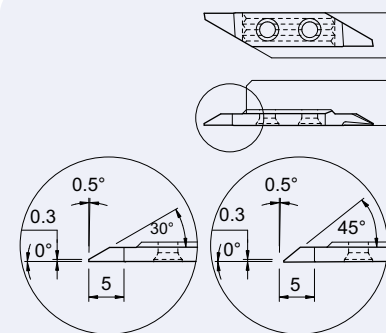

30°

45°

60°



Art. N°	TIN	TIALN	N (µK20)	HTIN	HTA	HN (µK10)
722-30	■	■	■	□	□	□
722-45	■	■	■	■	■	■
722-60	■	■	■	□	□	□

723

tourneur arrière
rückwärts drehen
back turning

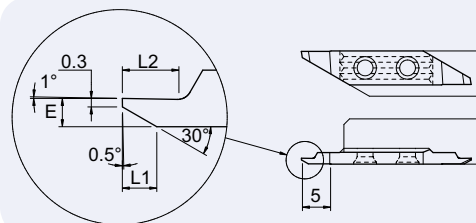

E	~L1	L2	Art. N°	TIN	TIALN	N (µK20)	HTIN	HTA	HN (µK10)
0.8	0.85	1.6	723-30-0.8	■	■	■	□	□	□
1.0	1.2	2.0	723-30-1.0	■	■	■	□	□	□
1.2	1.55	2.5	723-30-1.2	■	■	■	□	□	□
1.5	2.1	3.0	723-30-1.5	■	■	■	□	□	□
1.8	2.6	4.0	723-30-1.8	■	■	■	□	□	□
2.0	3.0	4.0	723-30-2.0	■	■	■	□	□	□

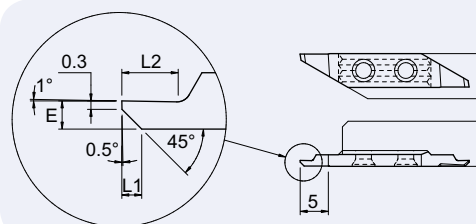

0.8	0.5	1.6	723-45-0.8	■	■	■	□	□	□
1.0	0.7	2.0	723-45-1.0	■	■	■	□	□	□
1.2	0.9	2.5	723-45-1.2	■	■	■	□	□	□
1.5	1.2	3.0	723-45-1.5	■	■	■	□	□	□
1.8	1.5	4.0	723-45-1.8	■	■	■	□	□	□
2.0	1.7	4.0	723-45-2.0	■	■	■	□	□	□

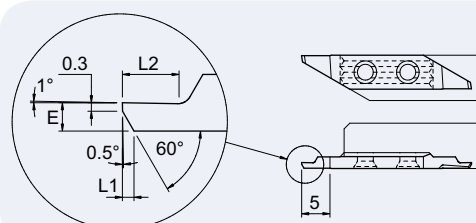

0.8	0.3	1.6	723-60-0.8	■	■	■	□	□	□
1.0	0.4	2.0	723-60-1.0	■	■	■	□	□	□
1.2	0.5	2.5	723-60-1.2	■	■	■	□	□	□
1.5	0.7	3.0	723-60-1.5	■	■	■	□	□	□
1.8	0.85	4.0	723-60-1.8	■	■	■	□	□	□
2.0	1.0	4.0	723-60-2.0	■	■	■	□	□	□

■ = Disponible / Verfügbar / Available
□ = Avec délai de livraison / Mit Lieferfrist / Available with delivery time



foncer tourner
einstechen und drehen
grooving and turning

714

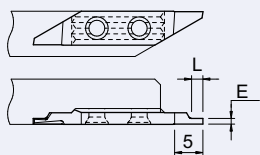

E	L	Art. N°	TIN	TIALN	N (μK20)	HTIN	HTA	HN (μK10)
0.5	1.0	714-0.5	■	■	■	□	□	□
0.6	1.0	714-0.6	■	■	■	□	□	□
0.7	1.5	714-0.7	■	■	■	□	□	□
0.8	1.5	714-0.8	■	■	■	□	□	□
0.9	2.0	714-0.9	■	■	■	□	□	□
1.0	2.0	714-1.0	■	■	■	□	■	■
1.1	2.0	714-1.1	■	■	■	□	□	□
1.2	2.5	714-1.2	■	■	■	□	□	□
1.3	2.5	714-1.3	■	■	■	□	□	□
1.4	3.0	714-1.4	■	■	■	□	□	□
1.5	3.0	714-1.5	■	■	■	■	■	■



fileter
Gewinde drehen
threading

716

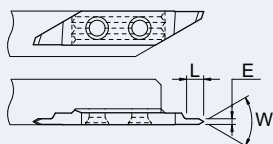

W	E	L	Art. N°	TIN	TIALN	N (μK20)	HTIN	HTA	HN (μK10)
60°	1.0	3	716-60-1.0	■	■	■			
60°	1.5	4	716-60-1.5	■	■	■			
55°	1.0	3	716-55-1.0	■	■	■			
55°	1.5	4	716-55-1.5	■	■	■			

■ = Disponible / Verfügbar / Available
□ = Avec délai de livraison / Mit Lieferfrist / Available with delivery time

724

foncer tourner
einstechen und drehen
grooving and turning

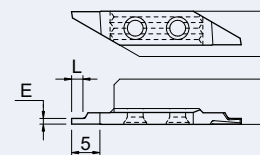

E	L	Art. N°	TIN	TIALN	N (μK20)	HTIN	HTA	HN (μK10)
0.5	1.0	724-0.5	■	■	■	□	□	□
0.6	1.0	724-0.6	■	■	■	□	□	□
0.7	1.5	724-0.7	■	■	■	□	□	□
0.8	1.5	724-0.8	■	■	■	□	□	□
0.9	2.0	724-0.9	■	■	■	□	□	□
1.0	2.0	724-1.0	■	■	■	□	□	□
1.1	2.0	724-1.1	■	■	■	□	□	□
1.2	2.5	724-1.2	■	■	■	□	□	□
1.3	2.5	724-1.3	■	■	■	□	□	□
1.4	3.0	724-1.4	■	■	■	□	□	□
1.5	3.0	724-1.5	■	■	■	■	■	■

726

fileter
Gewinde drehen
threading

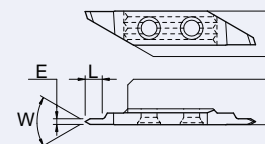

W	E	L	Art. N°	TIN	TIALN	N (μK20)	HTIN	HTA	HN (μK10)
60°	1.0	3	726-60-1.0	■	■	■			
60°	1.5	4	726-60-1.5	■	■	■			
55°	1.0	3	726-55-1.0	■	■	■			
55°	1.5	4	726-55-1.5	■	■	■			

■ = Disponible / Verfügbar / Available
□ = Avec délai de livraison / Mit Lieferfrist / Available with delivery time

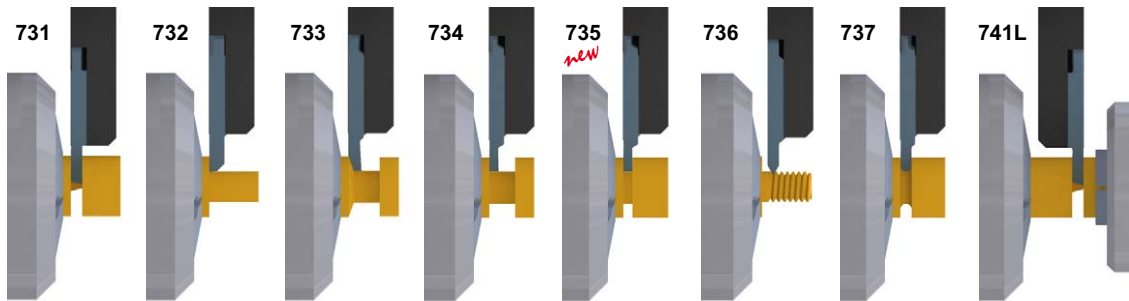

voir page :
siehe Seite :
see page :

1.26 1.28	1.32	1.32 1.34	1.36 1.38	1.38	1.40	1.40	1.30
--------------	------	--------------	--------------	------	------	------	------

porte-outils
Halter
holders

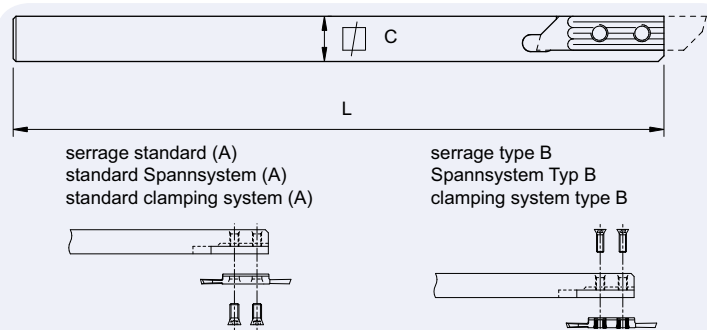

Chaque porte-outil est livré avec 2 paires de vis pour les 2 types de serrages
Alle Halter werden mit je 2 Spannschrauben für beide Spannsysteme geliefert
2 pairs of screws for both clamping systems are included with each tool holder

C	L	Art. N°
7 X 7	115	730-7 *
8 X 8	115	730-8
10 X 10	115	730-10
10 X 10	50	730-10-50
12 X 12	130	730-12
12 X 12	90	730-12-90
13 X 13	130	730-13
16 X 16	130	730-16
16 X 16	75	730-16-75
20 X 20	120	730-20

*730-7 : serrage A uniquement
*730-7 : nur mit A-Spannsystem
*730-7 : clamping A only

L coupe à gauche
Linksschneiden
left hand cut

utiliser des plaquettes série 730
Wendepplatten Serie 730 verwenden
use inserts series 730

R coupe à droite
Rechtsschneiden
right hand cut

utiliser des plaquettes série 740
Wendepplatten Serie 740 verwenden
use inserts series 740

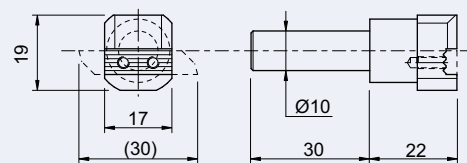
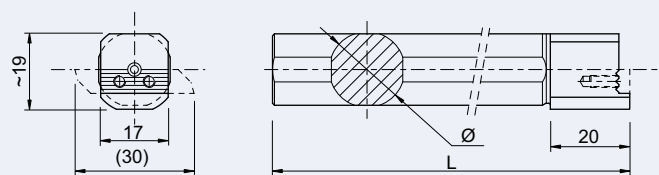

Ø	L	Art. N°
16	160	740/730-D16
19.05	160	740/730-D19.05
19.05	110	740/730D19.05-S
20	160	740/730-D20
22	110	740/730-D22
25	200	740/730-D25
25.4	200	740/730-D25.4

740/730-D10

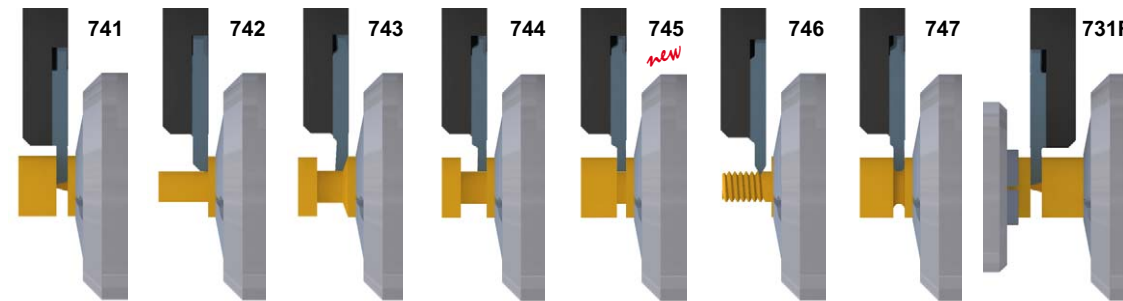

voir page :
siehe Seite :
see page :

1.27 1.29	1.33	1.33 1.35	1.37 1.39	1.39	1.41	1.41	1.31
--------------	------	--------------	--------------	------	------	------	------

porte-outils
Halter
holders

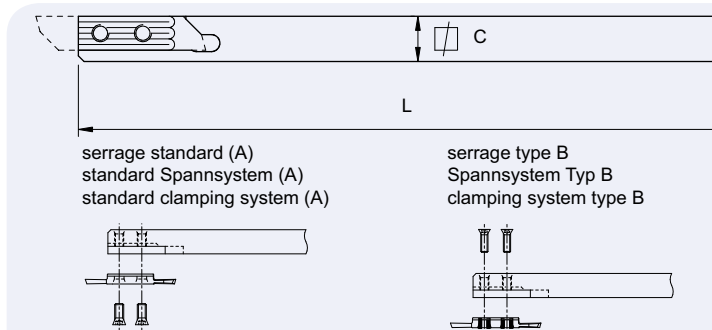

Chaque porte-outil est livré avec 2 paires de vis pour les 2 types de serrage
Alle Halter werden mit je 2 Spannschrauben für beide Spannsysteme geliefert
2 pairs of screws for both clamping systems are included with each tool holder

C	L	Art. N°
7 X 7	115	740-7 *
8 X 8	115	740-8
10 X 10	115	740-10
10 X 10	50	740-10-50
12 X 12	130	740-12
12 X 12	90	740-12-90
13 X 13	130	740-13
16 X 16	130	740-16
16 X 16	75	740-16-75
20 X 20	120	740-20

*740-7 : serrage A uniquement
*740-7 : nur mit A-Spannsystem
*740-7 : clamping A only

Pour le tronçonnage
de petites pièces

Zum Abstechen von
kleinen Werkstücken

For small parts
parting off

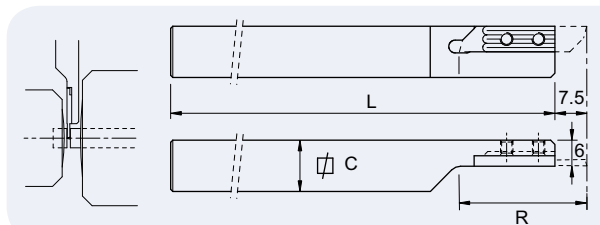
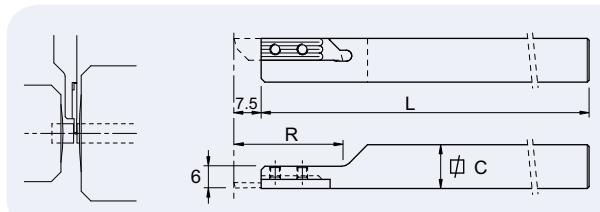

C	L	R	Art. N°
8 X 8	115	24	740-C-8
10 X 10	115	24	740-C-10
12 X 12	130	30	740-C-12
16 X 16	130	40	740-C-16

utiliser des plaquettes type 741
Wendepplatten Typ 741 verwenden
use inserts type 741

voir page :
siehe Seite :
see page :
1.27
1.29
1.30

C	L	R	Art. N°
8 X 8	115	20	730RC-8
10 X 10	115	24	730RC-10
12 X 12	130	30	730RC-12
16 X 16	130	40	730RC-16

utiliser des plaquettes type 731 R
Wendepplatten Typ 731 R verwenden
use inserts type 731 R

voir page :
siehe Seite :
see page :
1.31



plaquette ébauche
VHM-Rohling
blank insert

731-E

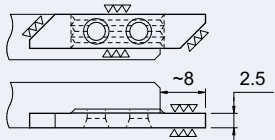

Art. N°	N (μK20)	HN (μK10)
731-E	■	■

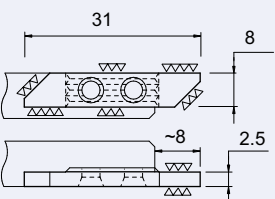

face de coupe polie
Schneidfläche poliert
cutting face polished



Art. N°	N (μK20)	HN (μK10)
731-EP	■	■



trouçonnage
abstechen
parting off

731

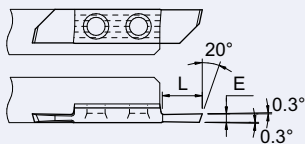

E	L	Art. N°	TIN	TiALN	N (μK20)	HTIN	HTA	HN (μK10)
0.8	5	731-0.8	■	■	■	□	□	□
1.0	5	731-1.0	■	■	■	□	■	■
1.2	5	731-1.2	■	■	■	□	□	□
1.5	7	731-1.5	■	■	■	■	■	■
1.8	7	731-1.8	■	■	■	□	□	□
2.0	7	731-2.0	■	■	■	□	□	□
2.5	7	731-2.5	■	■	■	□	□	□

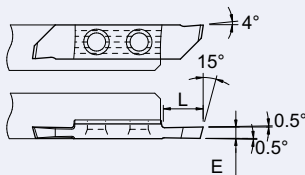

E	L	Art. N°	TIN	TiALN	N (μK20)	HTIN	HTA	HN (μK10)
1.0	5	731x4-1.0	■	■	■	□	□	□
1.5	7	731x4-1.5	■	■	■	□	□	□
2.0	7	731x4-2.0	■	■	■	□	□	□

7XX-XX-B



Sur demande pour serrage type B, voir page 1.02
Wahlweise für B-Spannsystem, siehe Seite 1.02
On request for B clamping system, see page 1.02

■ = Disponible / Verfügbar / Available
□ = Avec délai de livraison / Mit Lieferfrist
Available with delivery time

741-E

plaquette ébauche
VHM-Rohling
blank insert

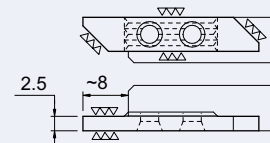

Art. N°	N (μK20)	HN (μK10)
741-E	■	■

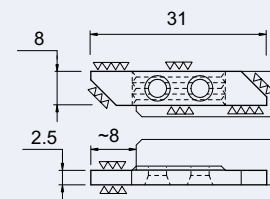

face de coupe polie
polierte Schneidfläche
cutting face polished



Art. N°	N (μK20)	HN (μK10)
741-EP	■	■

741

trouçonnage
abstechen
parting off

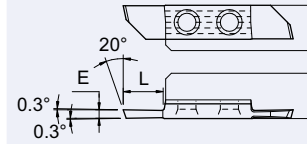

E	L	Art. N°	TIN	TiALN	N (μK20)	HTIN	HTA	HN (μK10)
0.8	5	741-0.8	■	■	■	■	■	■
1.0	5	741-1.0	■	■	■	■	■	■
1.2	5	741-1.2	■	■	■	□	■	■
1.5	7	741-1.5	■	■	■	■	■	■
1.8	7	741-1.8	■	■	■	□	□	□
2.0	7	741-2.0	■	■	■	□	□	□
2.5	7	741-2.5	■	■	■	□	□	□

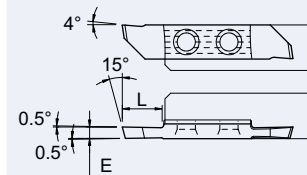

E	L	Art. N°	TIN	TiALN	N (μK20)	HTIN	HTA	HN (μK10)
1.0	5	741x4-1.0	■	■	■	□	□	□
1.5	7	741x4-1.5	■	■	■	□	□	□
2.0	7	741x4-2.0	■	■	■	□	□	□

7XX-XX-B



Sur demande pour serrage type B, voir page 1.02
Wahlweise für B-Spannsystem, siehe Seite 1.02
On request for B clamping system, see page 1.02

■ = Disponible / Verfügbar / Available
□ = Avec délai de livraison / Mit Lieferfrist
Available with delivery time



tronçonnage
abstechen
parting off

731

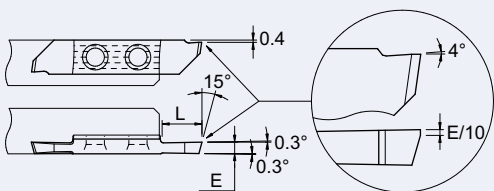

E	L	Art. N°	TIN	TIALN	N (µK20)	HTIN	HTA	HN (µK10)
1.5	7	731xf-1.5	■	■	■	■	■	■
2.0	7	731xf-2.0	■	■	■	□	□	□
2.5	7	731xf-2.5	■	■	■	□	□	□

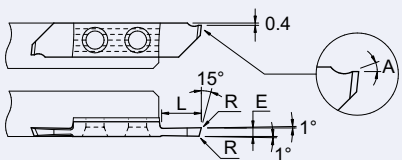

A=12°
R=0.03



1.0	5	731x12-1.0	■	■	■	□	□	□
1.5	7	731x12-1.5	■	■	■	□	□	□
2.0	7	731x12-2.0	■	■	■	□	□	□

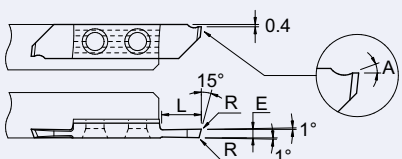

A=25°
R=0.03



1.0	5	731x25-1.0	■	■	■	□	□	□
1.5	7	731x25-1.5	■	■	■	□	□	□
2.0	7	731x25-2.0	■	■	■	□	□	□

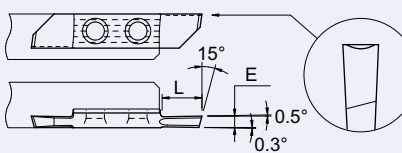

1.5	7	731u-1.5	■	■	■	□	□	□
2.0	7	731u-2.0	■	■	■	□	□	□

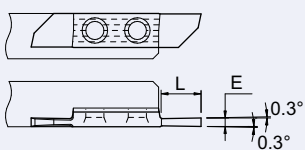

1.0	5	731n-1.0	■	■	■	□	□	□
1.5	7	731n-1.5	■	■	■	□	□	□

7XX-XX-B



Sur demande pour serrage type B, voir page 1.02
Wahlweise für B-Spannsystem, siehe Seite 1.02
On request for B clamping system, see page 1.02

■ = Disponible / Verfügbar / Available
□ = Avec délai de livraison / Mit Lieferfrist
Available with delivery time

741

tronçonnage
abstechen
parting off

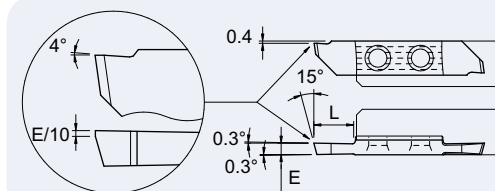

E	L	Art. N°	TIN	TIALN	N (µK20)	HTIN	HTA	HN (µK10)
1.2	7	741xf-1.2	■	■	■	□	□	□
1.5	7	741xf-1.5	■	■	■	■	■	■
2.0	7	741xf-2.0	■	■	■	■	■	■
2.5	7	741xf-2.5	■	■	■	□	□	□

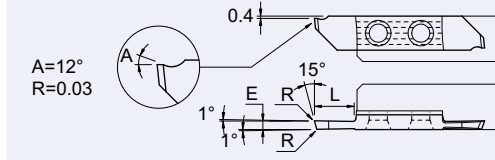

1.0	5	741x12-1.0	■	■	■	□	□	□
1.5	7	741x12-1.5	■	■	■	■	■	■
2.0	7	741x12-2.0	■	■	■	□	□	□

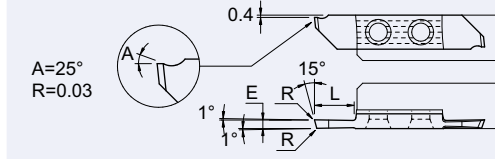

1.0	5	741x25-1.0	■	■	■	□	□	□
1.5	7	741x25-1.5	■	■	■	□	□	□
2.0	7	741x25-2.0	■	■	■	□	□	□

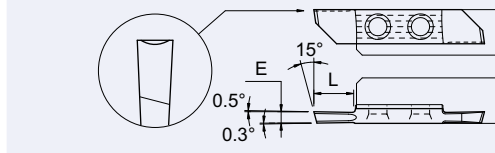

1.5	7	741u-1.5	■	■	■	□	□	□
2.0	7	741u-2.0	■	■	■	□	□	□

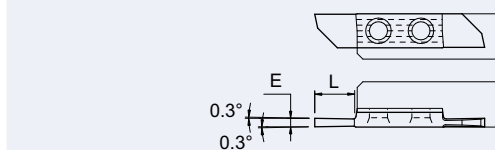

1.0	5	741n-1.0	■	■	■	□	□	□
1.5	7	741n-1.5	■	■	■	□	□	□

7XX-XX-B



Sur demande pour serrage type B, voir page 1.02
Wahlweise für B-Spannsystem, siehe Seite 1.02
On request for B clamping system, see page 1.02

■ = Disponible / Verfügbar / Available
□ = Avec délai de livraison / Mit Lieferfrist
Available with delivery time

coupe à gauche déportée
versetztes Linksschneiden
left cut off line

broche principale
Hauptspindel
Mainspindle

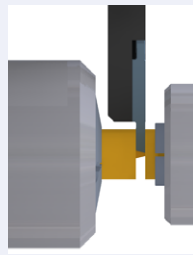

contre-broche
Gegenspindel
subspindle

Utiliser des porte-outils série 740 voir page 1.25
Halter Serie 740 verwenden, siehe Seite 1.25
Use 740 series holders see page 1.25



tronçonnage
abstechen
parting off

741L

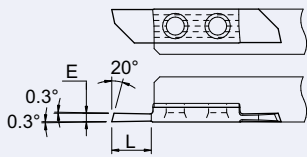

E	L	Art. N°	TIN	TIALN	N (µK20)	HTIN	HTA	HN (µK10)
1.0	5	741L-1.0	■	■	■	□	□	□
1.2	5	741L-1.2	■	■	■	□	□	□
1.5	7	741L-1.5	■	■	■	■	■	■
2.0	7	741L-2.0	■	■	■	□	□	□
2.5	7	741L-2.5	■	■	■	□	□	□

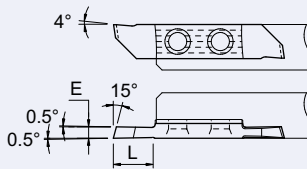

1.5	7	741Lx4-1.5	■	■	■	□	□	□
-----	---	------------	---	---	---	---	---	---

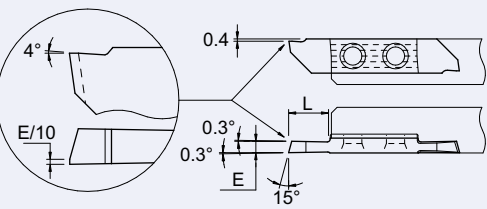

1.5	7	741Lxf-1.5	■	■	■	□	□	□
2.0	7	741Lxf-2.0	■	■	■	□	□	□
2.5	7	741Lxf-2.5	■	■	■	□	□	□

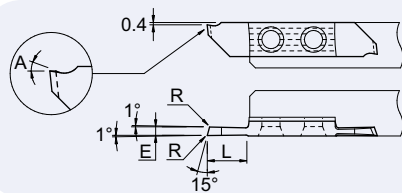

A	R	E	L	Art. N°	TIN	TIALN	N (µK20)	HTIN	HTA	HN (µK10)
12°	0.03	1.5	7	741Lx12-1.5	■	■	■	□	□	□
25°	0.03	1.5	7	741Lx25-1.5	■	■	■	□	□	□

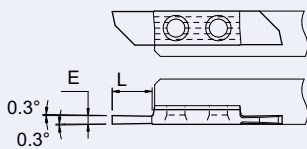

1.0	5	741n-1.0	■	■	■	□	□	□
1.5	7	741n-1.5	■	■	■	□	□	□

■ = Disponible / Verfügbar / Available
□ = Avec délai de livraison / Mit Lieferfrist
Available with delivery time

coupe à droite déportée
versetztes Rechtsschneiden
right cut off line

contre-broche
Gegenspindel
subspindle

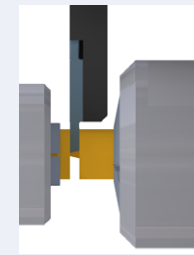

broche principale
Hauptspindel
Mainspindle

Utiliser des porte-outils série 730 voir page 1.24
Halter Serie 730 verwenden, siehe Seite 1.24
Use 730 series holders, see page 1.24

731R

tronçonnage
abstechen
parting off

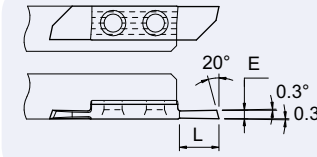

E	L	Art. N°	TIN	TIALN	N (µK20)	HTIN	HTA	HN (µK10)
1.0	5	731R-1.0	■	■	■	■	■	■
1.2	5	731R-1.2	■	■	■	□	□	□
1.5	7	731R-1.5	■	■	■	■	■	■
2.0	7	731R-2.0	■	■	■	□	□	□
2.5	7	731R-2.5	■	■	■	□	□	□

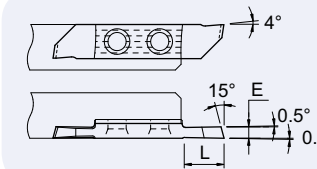

1.5	7	731Rx4-1.5	■	■	■	□	□	□
-----	---	------------	---	---	---	---	---	---

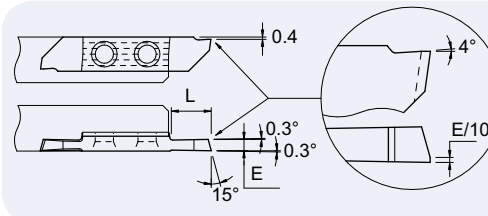

1.5	7	731Rxf-1.5	■	■	■	■	■	■
2.0	7	731Rxf-2.0	■	■	■	□	□	□
2.5	7	731Rxf-2.5	■	■	■	□	□	□

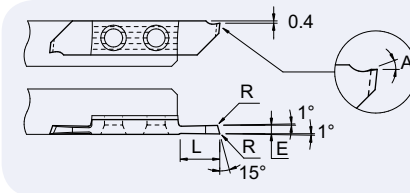

A	R	E	L	Art. N°	TIN	TIALN	N (µK20)	HTIN	HTA	HN (µK10)
12°	0.03	1.5	7	731Rx12-1.5	■	■	■	■	■	■
25°	0.03	1.5	7	731Rx25-1.5	■	■	■	□	□	□

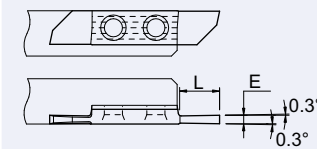

1.0	5	731n-1.0	■	■	■	□	□	□
1.5	7	731n-1.5	■	■	■	□	□	□

■ = Disponible / Verfügbar / Available
□ = Avec délai de livraison / Mit Lieferfrist
Available with delivery time



tourneur avant
vorwärts drehen
front turning

732

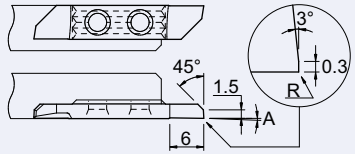

A	R	Art. N°	TIN	TIALN	N (µK20)	HTIN	HTA	HN (µK10)
0°	0	732	■	■	■	■	■	■
2°	0	732-2°	■	■	■	□	□	□

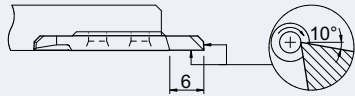

0°	0	732x	■	■	■	■	■	■
----	---	------	---	---	---	---	---	---

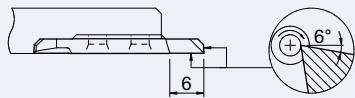

0°	0	732Px	■	■	■	□	□	□
----	---	-------	---	---	---	---	---	---



tourneur arrière
rückwärts drehen
back turning

733

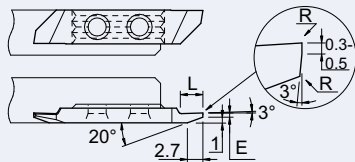

E	L	R	Art. N°	TIN	TIALN	N (µK20)	HTIN	HTA	HN (µK10)
0.5	3	0	733-0.5	■	■	■	□	■	■
0.5	3	0.08	733-0.5-R08	■	■	■	□	■	■
0.8	4	0	733-0.8	■	■	■	□	□	□
1.0	4	0	733-1.0	■	■	■	□	□	□
1.2	5	0	733-1.2	■	■	■	□	□	□
1.5	6	0	733-1.5	■	■	■	□	□	□

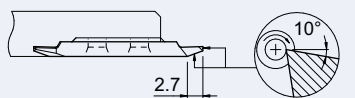

0.5	3	0	733x-0.5	■	■	■	□	□	□
0.5	3	0.08	733x-0.5-R08	■	■	■	□	□	□
0.8	4	0	733x-0.8	■	■	■	□	□	□
1.0	4	0	733x-1.0	■	■	■	□	□	□
1.2	5	0	733x-1.2	■	■	■	□	□	□
1.5	6	0	733x-1.5	■	■	■	□	□	□

7XX-XX-B



Sur demande pour serrage type B, voir page 1.02
Wahlweise für B-Spannsystem, siehe Seite 1.02
On request for B clamping system, see page 1.02

■ = Disponible / Verfügbar / Available
□ = Avec délai de livraison / Mit Lieferfrist
Available with delivery time

742

tourneur avant
vorwärts drehen
front turning

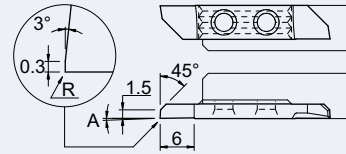

A	R	Art. N°	TIN	TIALN	N (µK20)	HTIN	HTA	HN (µK10)
0°	0	742	■	■	■	■	■	■
2°	0	742-2°	■	■	■	□	□	□

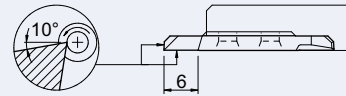

0°	0	742x	■	■	■	■	■	■
----	---	------	---	---	---	---	---	---

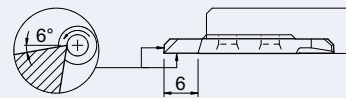

0°	0	742Px	■	■	■	□	□	□
----	---	-------	---	---	---	---	---	---

743

tourneur arrière
rückwärts drehen
back turning

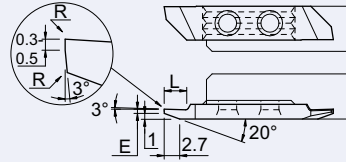

E	L	R	Art. N°	TIN	TIALN	N (µK20)	HTIN	HTA	HN (µK10)
0.5	3	0	743-0.5	■	■	■	□	■	■
0.5	3	0.08	743-0.5-R08	■	■	■	□	■	■
0.8	4	0	743-0.8	■	■	■	□	□	□
1.0	4	0	743-1.0	■	■	■	□	□	□
1.2	5	0	743-1.2	■	■	■	□	□	□
1.5	6	0	743-1.5	■	■	■	□	□	□

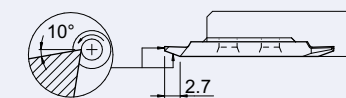

0.5	3	0	743x-0.5	■	■	■	□	■	■
0.5	3	0.08	743x-0.5-R08	■	■	■	□	■	■
0.8	4	0	743x-0.8	■	■	■	□	□	□
1.0	4	0	743x-1.0	■	■	■	□	□	□
1.2	5	0	743x-1.2	■	■	■	□	□	□
1.5	6	0	743x-1.5	■	■	■	□	□	□

7XX-XX-B



Sur demande pour serrage type B, voir page 1.02
Wahlweise für B-Spannsystem, siehe Seite 1.02
On request for B clamping system, see page 1.02

■ = Disponible / Verfügbar / Available
□ = Avec délai de livraison / Mit Lieferfrist
Available with delivery time



tourneur arrière
rückwärts drehen
back turning

733

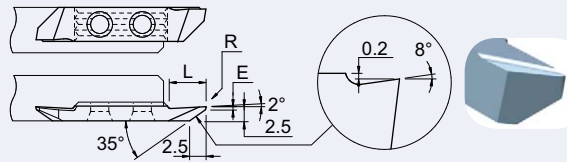

E	L	R	Art. N°	TIN	TIALN	N (µk20)	HTIN	HTA	HN (µk10)
~1.0	6.5	0	733vx-8°	■	■	■	■	■	■
~1.0	6.5	0.08	733vx-8°-R08	■	■	■	□	□	□

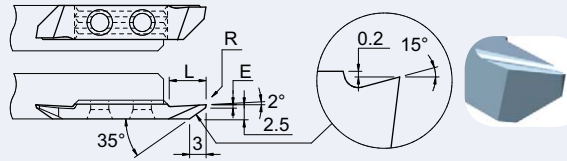

E	L	R	Art. N°	TIN	TIALN	N (µk20)	HTIN	HTA	HN (µk10)
0.5	6.5	0	733vx-15°	■	■	■	□	■	■
0.5	6.5	0.08	733vx-15°-R08	■	■	■	□	□	□

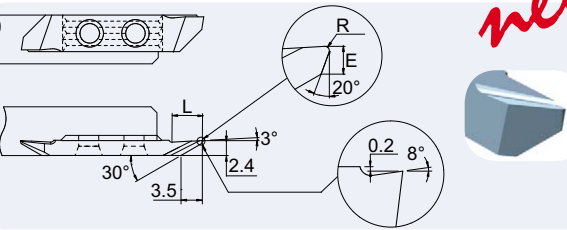

E	L	R	Art. N°	TIN	TIALN	N (µk20)	HTIN	HTA	HN (µk10)
0.5	6	0.08	733vx-805-R08	■	■	■	□	■	■



tourneur arrière / pré-coupe
rückwärts drehen / vorstechen
back turning / pre-parting off

733P

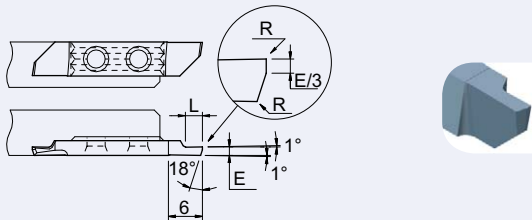

E	L	R	Art. N°	TIN	TIALN	N (µk20)	HTIN	HTA	HN (µk10)
0.8	2	0	733P-0.8	■	■	■	□	□	□
1.0	2	0	733P-1.0	■	■	■	□	□	□
1.2	2.5	0	733P-1.2	■	■	■	□	□	□
1.5	3	0	733P-1.5	■	■	■	□	□	□

7XX-XX-B



Sur demande pour serrage type B, voir page 1.02
Wahlweise für B-Spannsystem, siehe Seite 1.02
On request for B clamping system, see page 1.02

■ = Disponible / Verfügbar / Available
□ = Avec délai de livraison / Mit Lieferfrist
Available with delivery time

743

tourneur arrière
rückwärts drehen
back turning

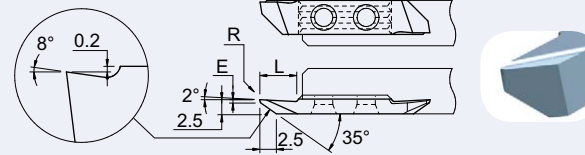

E	L	R	Art. N°	TIN	TIALN	N (µk20)	HTIN	HTA	HN (µk10)
~1.0	6.5	0	743vx-8°	■	■	■	□	■	■
~1.0	6.5	0.08	743vx-8°-R08	■	■	■	□	□	□

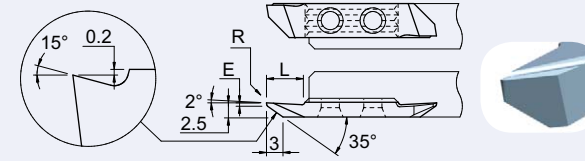

E	L	R	Art. N°	TIN	TIALN	N (µk20)	HTIN	HTA	HN (µk10)
0.5	6.5	0	743vx-15°	■	■	■	□	■	■
0.5	6.5	0.08	743vx-15°-R08	■	■	■	□	□	□

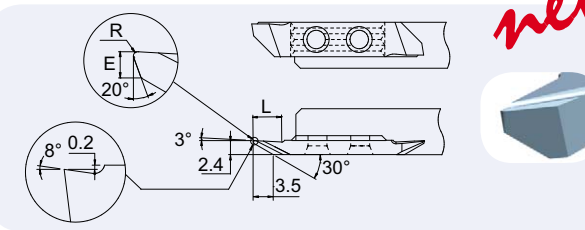

E	L	R	Art. N°	TIN	TIALN	N (µk20)	HTIN	HTA	HN (µk10)
0.5	6	0.08	743vx-805-R08	■	■	■	□	■	■

743P

tourneur arrière / pré-coupe
rückwärts drehen / vorstechen
back turning / pre-parting off

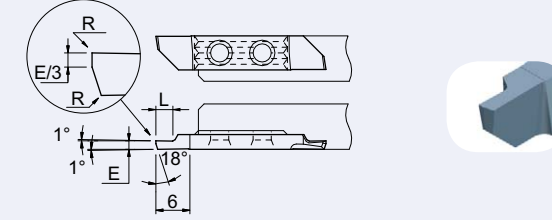

E	L	R	Art. N°	TIN	TIALN	N (µk20)	HTIN	HTA	HN (µk10)
0.8	2	0	743P-0.8	■	■	■	□	□	□
1.0	2	0	743P-1.0	■	■	■	□	□	□
1.2	2.5	0	743P-1.2	■	■	■	□	□	□
1.5	3	0	743P-1.5	■	■	■	□	□	□

7XX-XX-B



Sur demande pour serrage type B, voir page 1.02
Wahlweise für B-Spannsystem, siehe Seite 1.02
On request for B clamping system, see page 1.02

■ = Disponible / Verfügbar / Available
□ = Avec délai de livraison / Mit Lieferfrist
Available with delivery time



foncer tourner
einstechen und drehen
grooving and turning

734

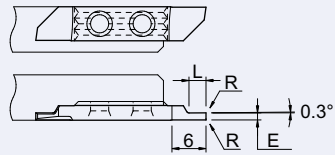

E	L	R	Art. N°	TIN TIALN N (µK20)	HTIN HTA HN (µK10)
0.5	1.5	0	734-0.5	■ ■ ■	□ □ □
0.6	1.8	0	734-0.6	■ ■ ■	□ □ □
0.75	2	0	734-0.75	■ ■ ■	□ □ □
0.8	2	0	734-0.8	■ ■ ■	□ □ □
0.95	3	0	734-0.95	■ ■ ■	□ □ □
1.0	2.5	0	734-1.0	■ ■ ■	■ ■ ■
1.0	2.5	0.08	734-1.0-R08	■ ■ ■	□ ■ ■
1.2	3	0	734-1.2	■ ■ ■	□ □ □
1.5	3	0	734-1.5	■ ■ ■	■ ■ ■
1.5	3	0.08	734-1.5-R08	■ ■ ■	□ ■ ■
1.8	4	0	734-1.8	■ ■ ■	□ □ □
2.0	4	0	734-2.0	■ ■ ■	□ ■ ■
2.0	4	0.08	734-2.0-R08	■ ■ ■	□ ■ ■
2.5	6	0	734-2.5	■ ■ ■	□ □ □

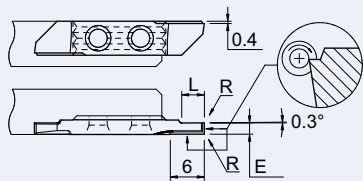

E	L	R	Art. N°	TIN TIALN N (µK20)	HTIN HTA HN (µK10)
1.0	2	0	734vs-1.0	■ ■ ■	□ □ □
1.2	2.5	0	734vs-1.2	■ ■ ■	□ □ □
1.5	3	0	734vs-1.5	■ ■ ■	□ □ □
1.8	4	0	734vs-1.8	■ ■ ■	□ □ □
2.0	4	0	734vs-2.0	■ ■ ■	□ □ □
2.5	6	0	734vs-2.5	■ ■ ■	□ □ □

7XX-XX-B



Sur demande pour serrage type B, voir page 1.02
Wahlweise für B-Spannsystem, siehe Seite 1.02
On request for B clamping system, see page 1.02

■ = Disponible / Verfügbar / Available
□ = Avec délai de livraison / Mit Lieferfrist
Available with delivery time



foncer tourner
einstechen und drehen
grooving and turning

744

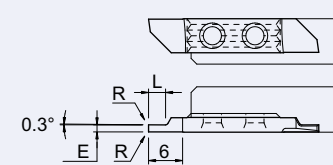

E	L	R	Art. N°	TIN TIALN N (µK20)	HTIN HTA HN (µK10)
0.5	1.5	0	744-0.5	■ ■ ■	■ ■ ■
0.6	1.8	0	744-0.6	■ ■ ■	□ □ □
0.75	2	0	744-0.75	■ ■ ■	□ □ □
0.8	2	0	744-0.8	■ ■ ■	■ ■ ■
0.9	2.5	0	744-0.9	■ ■ ■	□ □ □
0.95	3	0	744-0.95	■ ■ ■	□ □ □
1.0	2.5	0	744-1.0	■ ■ ■	■ ■ ■
1.0	2.5	0.08	744-1.0-R08	■ ■ ■	□ ■ ■
1.2	3	0	744-1.2	■ ■ ■	□ □ □
1.5	3	0	744-1.5	■ ■ ■	■ ■ ■
1.5	3	0.08	744-1.5-R08	■ ■ ■	□ ■ ■
1.5	3	0.20	744-1.5-R20	■ ■ ■	□ ■ ■
1.8	4	0	744-1.8	■ ■ ■	□ □ □
2.0	4	0	744-2.0	■ ■ ■	□ □ □
2.0	4	0.08	744-2.0-R08	■ ■ ■	□ ■ ■
2.0	4	0.20	744-2.0-R20	■ ■ ■	□ ■ ■
2.5	6	0	744-2.5	■ ■ ■	□ □ □

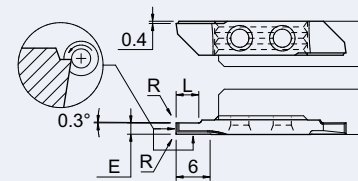

E	L	R	Art. N°	TIN TIALN N (µK20)	HTIN HTA HN (µK10)
1.0	2	0	744vs-1.0	■ ■ ■	□ □ □
1.2	2.5	0	744vs-1.2	■ ■ ■	□ □ □
1.5	3	0	744vs-1.5	■ ■ ■	□ □ □
1.8	4	0	744vs-1.8	■ ■ ■	□ □ □
2.0	4	0	744vs-2.0	■ ■ ■	□ □ □
2.5	6	0	744vs-2.5	■ ■ ■	□ □ □

7XX-XX-B



Sur demande pour serrage type B, voir page 1.02
Wahlweise für B-Spannsystem, siehe Seite 1.02
On request for B clamping system, see page 1.02

■ = Disponible / Verfügbar / Available
□ = Avec délai de livraison / Mit Lieferfrist
Available with delivery time



foncer tourner
einstechen und drehen
grooving and turning

734

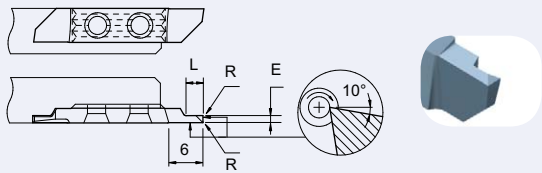

E	L	R	Art. N°	TIN	TIALN	N (µK20)	HTIN	HTA	HN (µK10)
0.8	2	0	734x-0.8	■	■	■	□	□	□
1.0	2.5	0	734x-1.0	■	■	■	□	□	□
1.0	2.5	0.08	734x-1.0-R08	■	■	■	□	□	□
1.2	3	0	734x-1.2	■	■	■	□	□	□
1.5	3	0	734x-1.5	■	■	■	■	■	■
1.5	3	0.08	734x-1.5-R08	■	■	■	□	□	□
1.8	4	0	734x-1.8	■	■	■	□	□	□
2.0	4	0	734x-2.0	■	■	■	□	□	□
2.0	4	0.08	734x-2.0-R08	■	■	■	□	□	□
2.0	4	0.20	734x-2.0-R20	■	■	■	□	□	□
2.5	6	0	734x-2.5	■	■	■	□	□	□



pour un meilleur contrôle des copeaux
für eine bessere Spankontrolle
for a better chip-control

ZX-Geometry

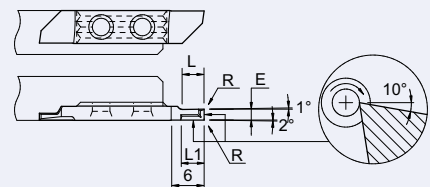

E	L	L1	R	Art. N°	TIN	TIALN	N (µK20)	HTIN	HTA	HN (µK10)
1.0	2.5	3	0.01	734zx10-1.0	□	■	■			
1.5	4	4	0.01	734zx10-1.5	□	■	■			
1.5	4	4	0.08	734zx10-1.5-R08	□	■	■			
2.0	4	4	0.01	734zx10-2.0	□	■	■			
2.0	4	4	0.08	734zx10-2.0-R08	□	■	■			
2.5	6	4	0.01	734zx10-2.5	□	■	■			

avance minimale 0.02 mm
für Vorschub ab 0.02 mm
for Feed from 0.02 mm



new

autres géométries possibles sur demande
andere Spangeometrien möglich
other cutting geometries also possible on request



gorges
einstechen
grooving

735

new

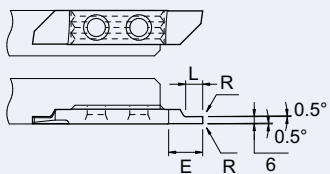

E ± 0.01	L	R	Art. N°	TIN	TIALN	N (µK20)	HTIN	HTA	HN (µK10)
0.2	0.2	0	735-0202	■	■	■	□	□	□
0.3	0.3	0	735-0303	■	■	■	□	□	□
0.4	0.4	0	735-0404	■	■	■	□	□	□

7XX-XX-B Sur demande pour serrage type B, voir page 1.02
Wahlweise für B-Spannsystem, siehe Seite 1.02
On request for B clamping system, see page 1.02

■ = Disponible / Verfügbar / Available
□ = Avec délai de livraison / Mit Lieferfrist
Available with delivery time

744

foncer tourner
einstechen und drehen
grooving and turning

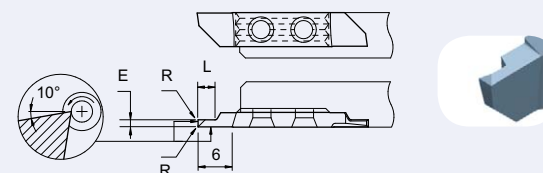

E	L	R	Art. N°	TIN	TIALN	N (µK20)	HTIN	HTA	HN (µK10)
0.8	2	0	744x-0.8	■	■	■	□	□	□
1.0	2.5	0	744x-1.0	■	■	■	□	□	□
1.0	2.5	0.08	744x-1.0-R08	■	■	■	□	□	□
1.2	3	0	744x-1.2	■	■	■	□	□	□
1.5	3	0	744x-1.5	■	■	■	■	■	■
1.5	3	0.08	744x-1.5-R08	■	■	■	□	□	□
1.5	3	0.20	744x-1.5-R20	■	■	■	□	□	□
1.8	4	0	744x-1.8	■	■	■	□	□	□
2.0	4	0	744x-2.0	■	■	■	□	□	□
2.0	4	0.08	744x-2.0-R08	■	■	■	□	□	□
2.0	4	0.20	744x-2.0-R20	■	■	■	□	□	□
2.5	6	0	744x-2.5	■	■	■	□	□	□

ZX-Geometry

pour un meilleur contrôle des copeaux
für eine bessere Spankontrolle
for a better chip-control

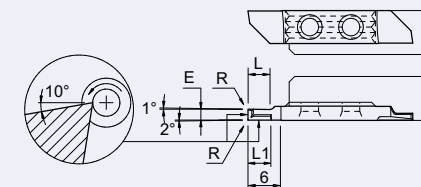

E	L	L1	R	Art. N°	TIN	TIALN	N (µK20)	HTIN	HTA	HN (µK10)
1.0	2.5	3	0.01	744zx10-1.0	□	■	■			
1.5	4	4	0.01	744zx10-1.5	□	■	■			
1.5	4	4	0.08	744zx10-1.5-R08	□	■	■			
2.0	4	4	0.01	744zx10-2.0	□	■	■			
2.0	4	4	0.08	744zx10-2.0-R08	□	■	■			
2.5	6	4	0.01	744zx10-2.5	□	■	■			

avance minimale 0.02 mm
für Vorschub ab 0.02 mm
for Feed from 0.02 mm

new



autres géométries possibles sur demande
andere Spangeometrien auf Anfrage möglich
other cutting geometries also possible on request

745

gorges
einstechen
grooving

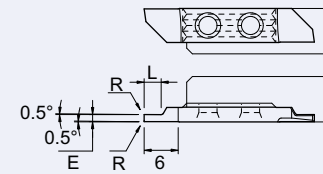

E ± 0.01	L	R	Art. N°	TIN	TIALN	N (µK20)	HTIN	HTA	HN (µK10)
0.2	0.2	0	745-0202	■	■	■	□	□	□
0.3	0.3	0	745-0303	■	■	■	□	□	□
0.4	0.4	0	745-0404	□	■	■	□	□	□

7XX-XX-B Sur demande pour serrage type B, voir page 1.02
Wahlweise für B-Spannsystem, siehe Seite 1.02
On request for B clamping system, see page 1.02

■ = Disponible / Verfügbar / Available
□ = Avec délai de livraison / Mit Lieferfrist
Available with delivery time



fileter
Gewinde drehen
threading

736

partial profile

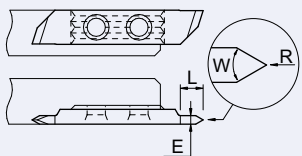

W	E	L	R	Art. N°	TIN	TIALN	N (µK20)	HTIN	HTA	HN (µK10)
60°	1.5	4	0	736-60-1.5	■	■	■	■	■	■
60°	1.5	4	0.02	736-60-1.5-R02	■	■	■	■	■	■
60°	2.0	6	0	736-60-2	■	■	■	■	■	■
60°	2.0	6	0.02	736-60-2-R02	■	■	■	■	■	■
55°	1.5	4	0	736-55-1.5	■	■	■	■	■	■
55°	2.0	6	0	736-55-2	■	■	■	■	■	■

partial profile

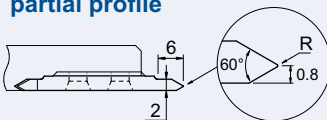

Pas Steigung Pitch P	R	Art. N°	TIN	TIALN	N (µK20)	HTIN	HTA	HN (µK10)
0.50-1.50	0.06	736-A60°	■	■	■	□	□	□

full profile

ISO metric

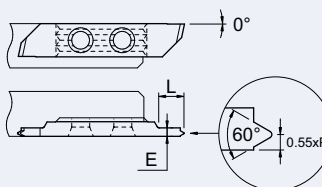

Pas Steigung Pitch P	E	L	Art. N°	TIN	TIALN	N (µK20)	HTIN	HTA	HN (µK10)
0.25	1.0	3	736-M-0.25	■	■	■	■	■	■
0.30	1.0	3	736-M-0.30	■	■	■	■	■	■
0.35	1.0	3	736-M-0.35	■	■	■	■	■	■
0.40	1.0	3	736-M-0.40	■	■	■	■	■	■
0.45	1.0	3	736-M-0.45	■	■	■	■	■	■
0.50	1.0	3	736-M-0.50	■	■	■	■	■	■
0.60	1.0	3	736-M-0.60	■	■	■	■	■	■
0.70	1.0	3	736-M-0.70	■	■	■	■	■	■
0.75	1.0	3	736-M-0.75	■	■	■	■	■	■
0.80	1.5	4.5	736-M-0.80	■	■	■	■	■	■
1.00	1.5	4.5	736-M-1.00	■	■	■	■	■	■
1.25	1.5	4.5	736-M-1.25	■	■	■	■	■	■
1.50	2.0	6	736-M-1.50	■	■	■	■	■	■
1.75	2.0	6	736-M-1.75	■	■	■	■	■	■

Pour de plus grands pas, voir série 756 à la page 1.64

Für grössere Steigungen, siehe Serie 756 auf Seite 1.64

For bigger pitch, see series 756 on page 1.64



plaquette à rayon
Radius-Wendeplatte
insert with radius

737

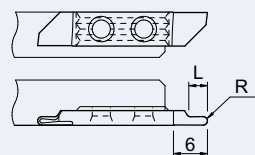

R	L	Art. N°	TIN	TIALN	N (µK20)	HTIN	HTA	HN (µK10)
0.5	2.5	737-R0.5	■	■	■	■	■	■
0.6	2.5	737-R0.6	■	■	■	■	■	■
0.75	3	737-R0.75	■	■	■	■	■	■
0.8	3	737-R0.8	■	■	■	■	■	■
1.0	4	737-R1.0	■	■	■	■	■	■

7XX-XX-B

Sur demande pour serrage type B, voir page 1.02
Wahlweise für B-Spannsystem, siehe Seite 1.02
On request for B clamping system, see page 1.02

■ = Disponible / Verfügbar / Available
□ = Avec délai de livraison / Mit Lieferfrist
Available with delivery time

746

fileter
Gewinde drehen
threading



partial profile

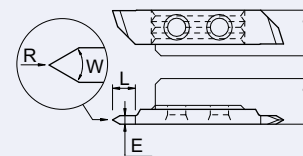

W	E	L	R	Art. N°	TIN	TIALN	N (µK20)	HTIN	HTA	HN (µK10)
60°	1.5	4	0	746-60-1.5	■	■	■	■	■	■
60°	1.5	4	0.02	746-60-1.5-R02	■	■	■	■	■	■
60°	2.0	6	0	746-60-2	■	■	■	■	■	■
60°	2.0	6	0.02	746-60-2-R02	■	■	■	■	■	■
55°	1.5	4	0	746-55-1.5	■	■	■	■	■	■
55°	2.0	6	0	746-55-2	■	■	■	■	■	■

partial profile

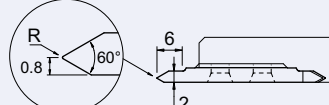

Pas Steigung Pitch P	R	Art. N°	TIN	TIALN	N (µK20)	HTIN	HTA	HN (µK10)
0.50-1.50	0.06	746-A60°	■	■	■	□	□	□

full profile

ISO metric

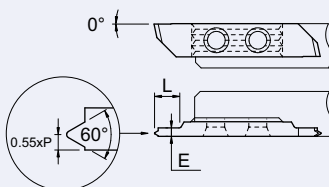

Pas Steigung Pitch P	E	L	Art. N°	TIN	TIALN	N (µK20)	HTIN	HTA	HN (µK10)
0.25	1.0	3	746-M-0.25	■	■	■	■	■	■
0.30	1.0	3	746-M-0.30	■	■	■	■	■	■
0.35	1.0	3	746-M-0.35	■	■	■	■	■	■
0.40	1.0	3	746-M-0.40	■	■	■	■	■	■
0.45	1.0	3	746-M-0.45	■	■	■	■	■	■
0.50	1.0	3	746-M-0.50	■	■	■	■	■	■
0.60	1.0	3	746-M-0.60	■	■	■	■	■	■
0.70	1.0	3	746-M-0.70	■	■	■	■	■	■
0.75	1.0	3	746-M-0.75	■	■	■	■	■	■
0.80	1.5	4.5	746-M-0.80	■	■	■	■	■	■
1.00	1.5	4.5	746-M-1.00	■	■	■	■	■	■
1.25	1.5	4.5	746-M-1.25	■	■	■	■	■	■
1.50	2.0	6	746-M-1.50	■	■	■	■	■	■
1.75	2.0	6	746-M-1.75	■	■	■	■	■	■

Pour de plus grands pas, voir série 766 à la page 1.65

Für grössere Steigungen, siehe Serie 766 auf Seite 1.65

For bigger pitch, see series 766 on page 1.65

747

plaquette à rayon
Radius-Wendeplatte
insert with radius

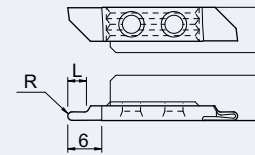

R	L	Art. N°	TIN	TIALN	N (µK20)	HTIN	HTA	HN (µK10)
0.25	1.5	747-R0.25	■	■	■	■	■	■
0.5	2.5	747-R0.5	■	■	■	■	■	■
0.6	2.5	747-R0.6	■	■	■	■	■	■
0.75	3	747-R0.75	■	■	■	■	■	■
0.8	3	747-R0.8	■	■	■	■	■	■
1.0	4	747-R1.0	■	■	■	■	■	■

7XX-XX-B

Sur demande pour serrage type B, voir page 1.02
Wahlweise für B-Spannsystem, siehe Seite 1.02
On request for B clamping system, see page 1.02

■ = Disponible / Verfügbar / Available
□ = Avec délai de livraison / Mit Lieferfrist
Available with delivery time

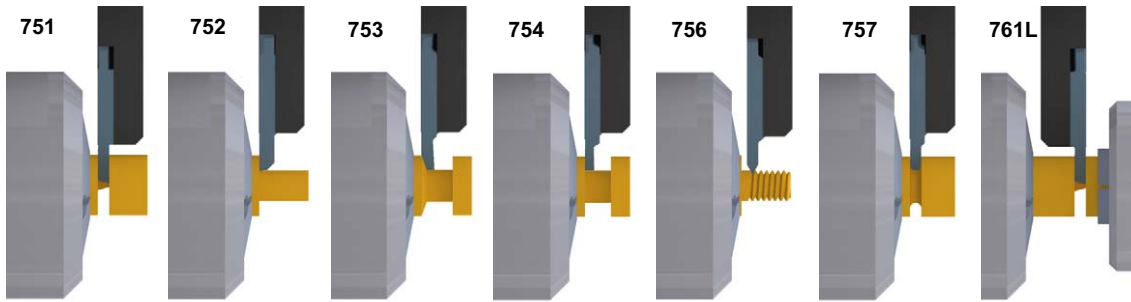

voir page :
siehe Seite :
see page :

1.46	1.54	1.54	1.60	1.64	1.66	1.50
1.48		1.56	1.62			1.52
		1.58				

porte-outils
Halter
holders

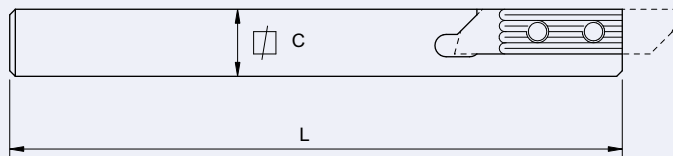

serrage standard (A)
standard Spannsystem (A)
standard clamping system (A)

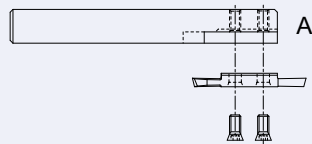

C	L	Art. N°
10 X 10	115	750-10
10 X 10	50	750-10-50
12 X 12	130	750-12
12 X 12	90	750-12-90

serrage type A et B
Spannsystem Typ A und B
clamping system A and B

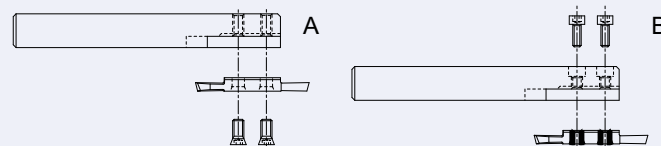

10 X 10	115	750-10-AB
12 X 12	130	750-12-AB
12 X 12	90	750-12-90-AB
13 X 13	130	750-13
14 X 14	130	750-14
16 X 16	130	750-16
16 X 16	75	750-16-75
20 X 20	120	750-20

Chaque porte-outil est livré avec 2 paires de vis pour les 2 types de serrages
Alle Halter werden mit je 2 Spannschrauben für beide Spannsysteme geliefert
2 pairs of screws for both clamping systems are included with each tool holder

serrage standard (A)
standard Spannsystem (A)
standard clamping system (A)



25 X 25	140	760 / 750 - 25
---------	-----	----------------

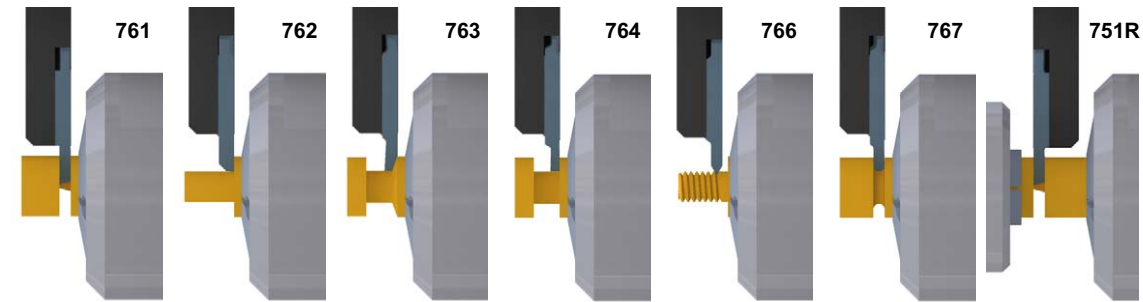

voir page :
siehe Seite :
see page :

1.47	1.55	1.55	1.61	1.65	1.67	1.45
1.49		1.57	1.63			1.51
		1.59				1.53

porte-outils
Halter
holders

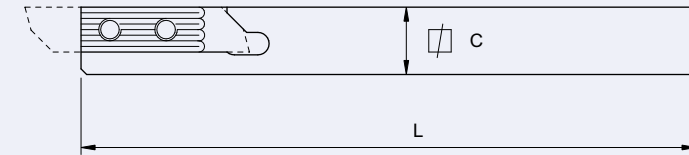

serrage standard (A)
standard Spannsystem (A)
standard clamping system (A)

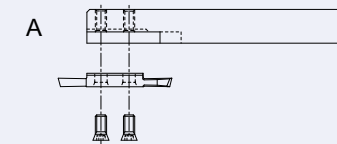

C	L	Art. N°
10 X 10	115	760-10
10 X 10	50	760-10-50
12 X 12	130	760-12
12 X 12	90	760-12-90

serrage type A et B
Spannsystem Typ A und B
clamping system A and B

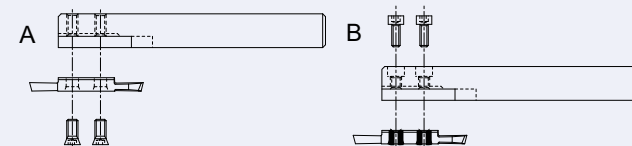

10 X 10	115	760-10-AB
12 X 12	130	760-12-AB
12 X 12	90	760-12-90-AB
13 X 13	130	760-13
14 X 14	130	760-14
16 X 16	130	760-16
16 X 16	75	760-16-75
20 X 20	120	760-20

Chaque porte-outil est livré avec 2 paires de vis pour les 2 types de serrages
Alle Halter werden mit je 2 Spannschrauben für beide Spannsysteme geliefert
2 pairs of screws for both clamping systems are included with each tool holder

serrage standard (A)
standard Spannsystem (A)
standard clamping system (A)

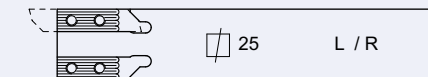

25 X 25	140	760 / 750 - 25
---------	-----	----------------

Pour le tronçonnage de petites pièces
Zum Abstechen von kleinen Werkstücken
For small parts parting off

porte-outils
Halter
holders

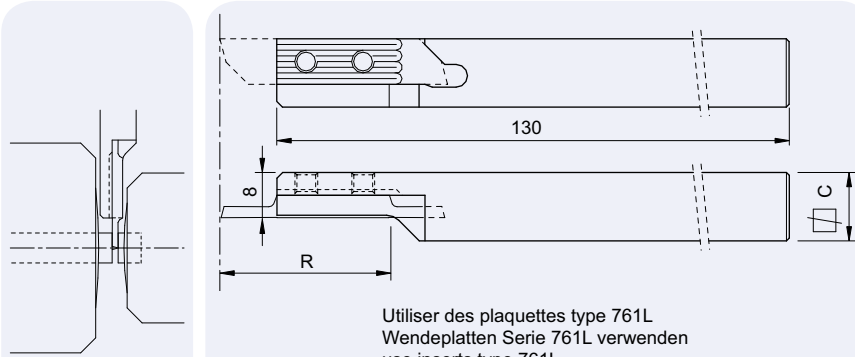

Utiliser des plaquettes type 761L
Wendeplatten Serie 761L verwenden
use inserts type 761L
voir pages :
siehe Seiten : 1.50 / 1.52 / 1.80
see pages :

C	R	Art. N°
16 X 16	40	760LC-16

L coupe à gauche
Linksschneiden
left hand cut

utiliser des plaquettes série 750
Wendeplatten Serie 750 verwenden
use inserts series 750

R coupe à droite
Rechtsschneiden
right hand cut

utiliser des plaquettes série 760
Wendeplatten Serie 760 verwenden
use inserts series 760

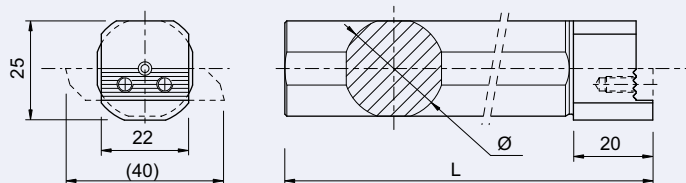

Ø	L	Art. N°
16	160	760/750-D16
19.05	160	760/750-D19.05
19.05	110	760/750-D19.05-S
20	160	760/750-D20
22	110	760/750-D22
25	200	760/750-D25
25.4	200	760/750-D25.4
25.4	125	760/750-D25.4-S

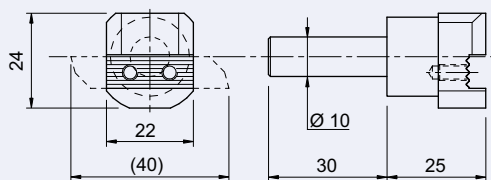

760/750-D10

Pour le tronçonnage
de petites pièces
Zum Abstechen von
kleinen Werkstücken
For small parts
parting off

porte-outils
Halter
holders

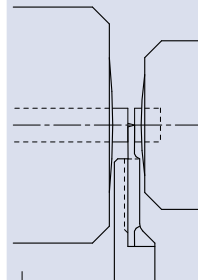

avec plaquettes
type 751R
mit Wendeplatten
Typ 751R
with inserts
type 751R

voir pages : 1.51
siehe Seiten : 1.53
see pages : 1.81

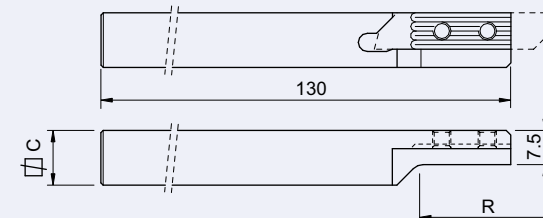

C	R	Art. N°
12 X 12	30	750RC-12
16 X 16	40	750RC-16

SPECIAL TORNOS AS14 / SAS16

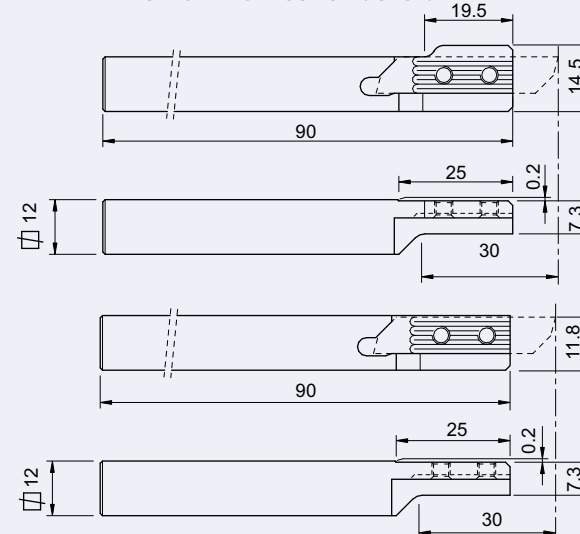

Art. N°
750RAS-12

Art. N°
750RAS12-H11.8

751

tronçonnage
abstechen
parting off

avec plaquettes
type 751RAS / RD
mit Wendeplatten
Typ 751RAS / RD
with inserts
type 751RAS / RD

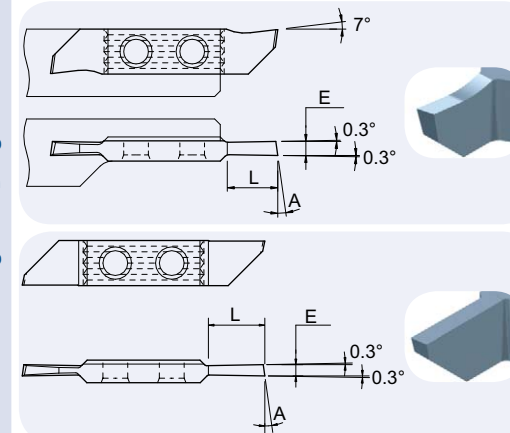

A	E	L	Art. N°	TIN	TiAlN	N (µk20)	HTIN	HTA	HN (µk10)
8°	1.6	7.5	751RAS-1.6-8°	■	■	■	□	□	□
8°	2.0	9	751RAS-2.0-8°	■	■	■	□	■	■
8°	2.5	9	751RAS-2.5-8°	■	■	■	□	□	□
15°	1.6	7.5	751RAS-1.6-15°	■	■	■	□	□	□
15°	2.0	9	751RAS-2.0-15°	■	■	■	□	□	□
15°	2.5	9	751RAS-2.5-15°	■	■	■	□	□	□
8°	1.0	5	751RD-1.0-8°	■	■	■	□	□	□
15°	1.0	5	751RD-1.0-15°	■	■	■	□	□	□
8°	1.2	5	751RD-1.2-8°	■	■	■	□	□	□
8°	1.5	8	751RD-1.5-8°	■	■	■	■	■	■
15°	1.5	8	751RD-1.5-15°	■	■	■	□	□	□
8°	1.6	8	751RD-1.6-8°	■	■	■	□	□	□
8°	1.8	10	751RD-1.8-8°	■	■	■	□	□	□
8°	2.0	10	751RD-2.0-8°	■	■	■	□	□	□
15°	2.0	10	751RD-2.0-15°	■	■	■	□	□	□
8°	2.5	10	751RD-2.5-8°	■	■	■	□	□	□

■ = Disponible / Verfügbar / Available
□ = Avec délai de livraison / Mit Lieferfrist
Available with delivery time



plaquette ébauche
VHM-Rohling
blank insert

751-E

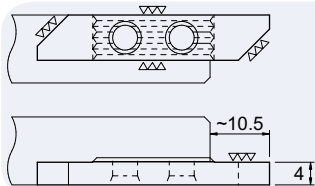

Art. N°	N (μK20)	HN (μK10)
751-E	■	■

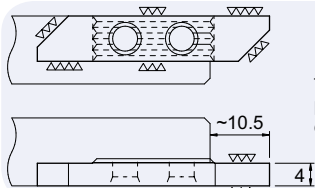

face de coupe polie
polierte Schneidfläche
cutting face polished



751-EP	■	■
--------	---	---



tronçonnage
abstechen
parting off

751

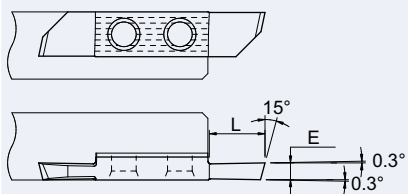

E	L	Art. N°	TIN	TIALN	N (μK20)	HTIN	HTA	HN (μK10)
1.0	5	751-1.0	■	■	■	□	■	■
1.2	5	751-1.2	■	■	■	□	□	□
1.5	7.5	751-1.5	■	■	■	□	■	■
1.8	7.5	751-1.8	■	■	■	□	□	□
2.0	10	751-2.0	■	■	■	□	■	■
2.2	10	751-2.2	■	■	■	□	□	□
2.5	10	751-2.5	■	■	■	□	■	■
3.0	10	751-3.0	■	■	■	□	□	□

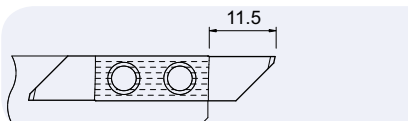

2.0	11.5	751s-2.0	■	■	■	□	□	□
2.2	11.5	751s-2.2	■	■	■	□	□	□
2.5	11.5	751s-2.5	■	■	■	□	□	□
3.0	11.5	751s-3.0	■	■	■	□	□	□

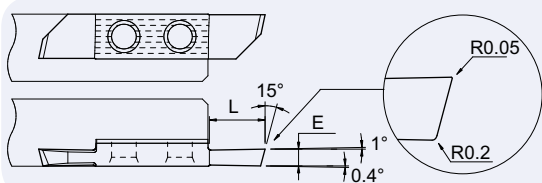

1.5	7.5	751-1.5-R05	■	■	■	□	□	□
2.0	10	751-2.0-R05	■	■	■	□	□	□
2.5	10	751-2.5-R05	■	■	■	□	□	□

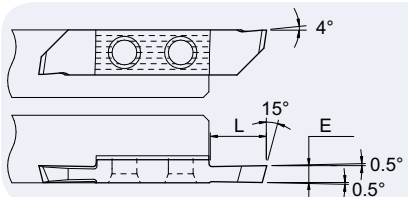

2.0	10	751x4-2.0	■	■	■	□	□	□
-----	----	-----------	---	---	---	---	---	---

7XX-XX-B



Sur demande pour serrage type B, voir page 1.02
Wahlweise für B-Spannsystem, siehe Seite 1.02
On request for B clamping system, see page 1.02

■ = Disponible / Verfügbar / Available
□ = Avec délai de livraison / Mit Lieferfrist
Available with delivery time



plaquette ébauche
VHM-Rohling
blank insert

761-E

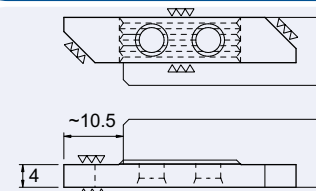

Art. N°	N (μK20)	HN (μK10)
761-E	■	■

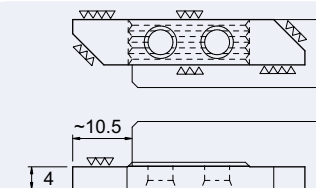

face de coupe polie
polierte Schneidfläche
cutting face polished



761-EP	■	■
--------	---	---

761

tronçonnage
abstechen
parting off

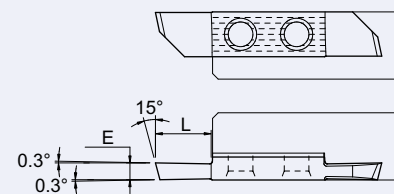

E	L	Art. N°	TIN	TIALN	N (μK20)	HTIN	HTA	HN (μK10)
1.0	5	761-1.0	■	■	■	□	■	■
1.2	5	761-1.2	■	■	■	□	□	□
1.5	7.5	761-1.5	■	■	■	□	■	■
1.8	7.5	761-1.8	■	■	■	□	□	□
2.0	10	761-2.0	■	■	■	□	■	■
2.2	10	761-2.2	■	■	■	□	□	□
2.5	10	761-2.5	■	■	■	□	■	■
3.0	10	761-3.0	■	■	■	□	□	□

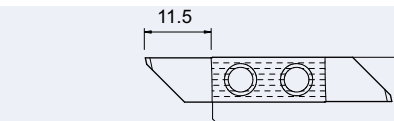

2.0	11.5	761s-2.0	■	■	■	□	□	□
2.2	11.5	761s-2.2	■	■	■	□	□	□
2.5	11.5	761s-2.5	■	■	■	□	□	□
3.0	11.5	761s-3.0	■	■	■	□	□	□

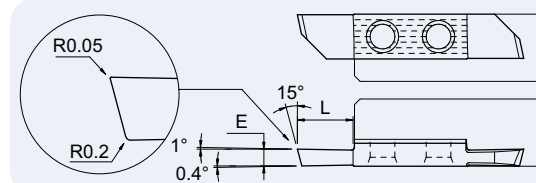

1.5	7.5	761-1.5-R05	■	■	■	□	□	□
2.0	10	761-2.0-R05	■	■	■	□	□	□
2.5	10	761-2.5-R05	■	■	■	□	□	□

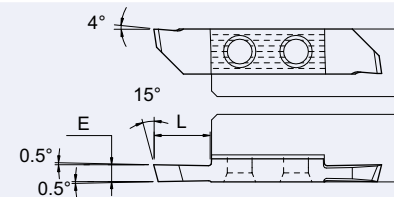

1.5	7.5	761x4-1.5	■	■	■	□	□	□
2.0	10	761x4-2.0	■	■	■	□	□	□
2.5	10	761x4-2.5	■	■	■	□	□	□

7XX-XX-B



Sur demande pour serrage type B, voir page 1.02
Wahlweise für B-Spannsystem, siehe Seite 1.02
On request for B clamping system, see page 1.02

■ = Disponible / Verfügbar / Available
□ = Avec délai de livraison / Mit Lieferfrist
Available with delivery time



tronçonnage
abstechen
parting off

751

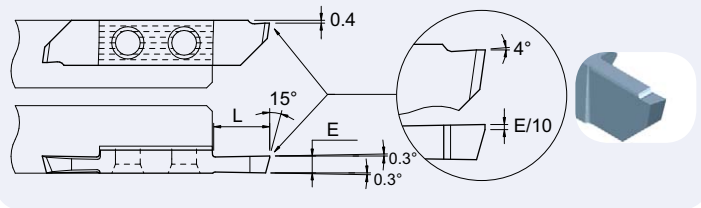

E	L	Art. N°	TiN	TiAlN	N (µK20)	HTiN	HTA	HN (µK10)
1.5	7.5	751xf-1.5	■	■	■	□	□	□
2.0	10	751xf-2.0	■	■	■	■	■	■
2.2	10	751xf-2.2	■	■	■	□	□	□
2.5	10	751xf-2.5	■	■	■	□	□	□
3.0	10	751xf-3.0	■	■	■	□	□	□

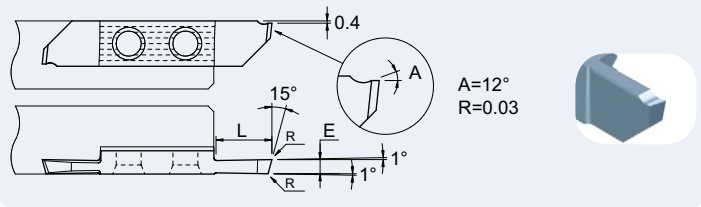

E	L	Art. N°	TiN	TiAlN	N (µK20)	HTiN	HTA	HN (µK10)
1.5	7.5	751x12-1.5	■	■	■	□	□	□
2.0	10	751x12-2.0	■	■	■	□	■	■
2.5	10	751x12-2.5	■	■	■	□	□	□

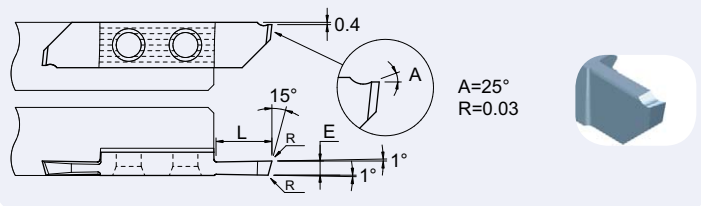

E	L	Art. N°	TiN	TiAlN	N (µK20)	HTiN	HTA	HN (µK10)
1.5	7.5	751x25-1.5	■	■	■	□	□	□
2.0	10	751x25-2.0	■	■	■	□	□	□
2.5	10	751x25-2.5	■	■	■	□	□	□

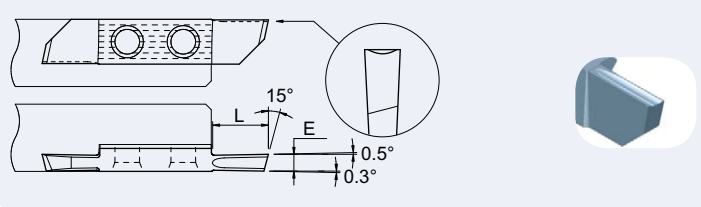

E	L	Art. N°	TiN	TiAlN	N (µK20)	HTiN	HTA	HN (µK10)
2.0	10	751u-2.0	■	■	■	□	□	□

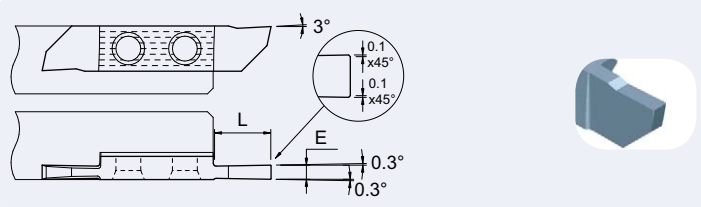

E	L	Art. N°	TiN	TiAlN	N (µK20)	HTiN	HTA	HN (µK10)
2.0	10	751nxf-2.0	■	■	■	□	□	□
2.5	10	751nxf-2.5	■	■	■	□	□	□
3.0	10	751nxf-3.0	■	■	■	□	□	□

7XX-XX-B



Sur demande pour serrage type B, voir page 1.02
Wahlweise für B-Spannsystem, siehe Seite 1.02
On request for B clamping system, see page 1.02

■ = Disponible / Verfügbar / Available
□ = Avec délai de livraison / Mit Lieferfrist
Available with delivery time

761

tronçonnage
abstechen
parting off

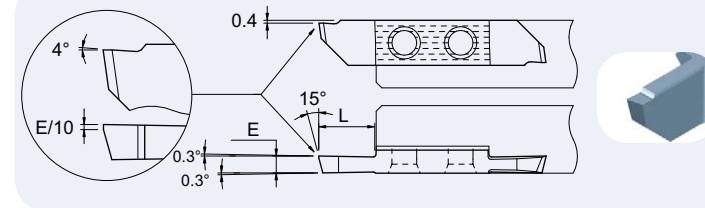

E	L	Art. N°	TiN	TiAlN	N (µK20)	HTiN	HTA	HN (µK10)
1.5	7.5	761xf-1.5	■	■	■	□	■	■
2.0	10	761xf-2.0	■	■	■	■	■	■
2.2	10	761xf-2.2	■	■	■	□	□	□
2.5	10	761xf-2.5	■	■	■	□	□	□
3.0	10	761xf-3.0	■	■	■	□	□	□

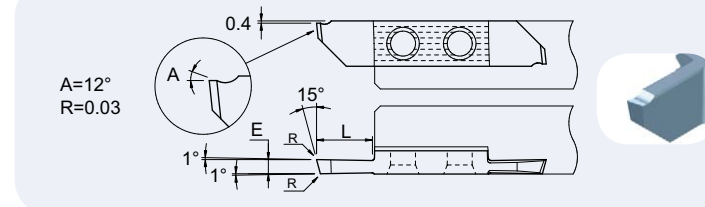

E	L	Art. N°	TiN	TiAlN	N (µK20)	HTiN	HTA	HN (µK10)
1.5	7.5	761x12-1.5	■	■	■	□	□	□
2.0	10	761x12-2.0	■	■	■	□	■	■
2.5	10	761x12-2.5	■	■	■	□	□	□

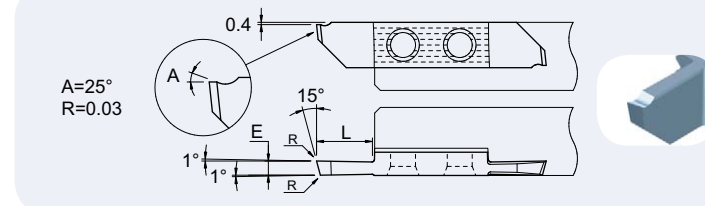

E	L	Art. N°	TiN	TiAlN	N (µK20)	HTiN	HTA	HN (µK10)
1.5	7.5	761x25-1.5	■	■	■	□	□	□
2.0	10	761x25-2.0	■	■	■	□	□	□
2.5	10	761x25-2.5	■	■	■	□	□	□

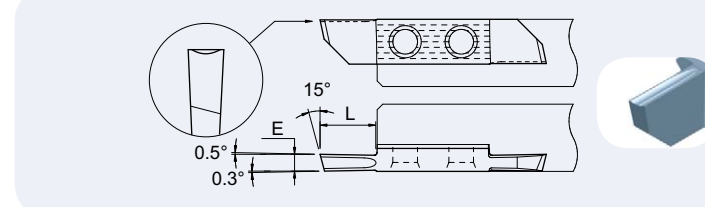

E	L	Art. N°	TiN	TiAlN	N (µK20)	HTiN	HTA	HN (µK10)
2.0	10	761u-2.0	■	■	■	□	□	□

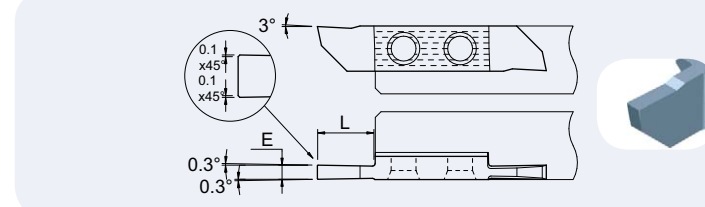

E	L	Art. N°	TiN	TiAlN	N (µK20)	HTiN	HTA	HN (µK10)
2.0	10	761nxf-2.0	■	■	■	□	□	□
2.5	10	761nxf-2.5	■	■	■	□	□	□
3.0	10	761nxf-3.0	■	■	■	□	□	□

7XX-XX-B



Sur demande pour serrage type B, voir page 1.02
Wahlweise für B-Spannsystem, siehe Seite 1.02
On request for B clamping system, see page 1.02

■ = Disponible / Verfügbar / Available
□ = Avec délai de livraison / Mit Lieferfrist
Available with delivery time

coupe à gauche déportée
versetztes Linksschneiden
left cut off line

broche principale
Hauptspindel
Mainspindle

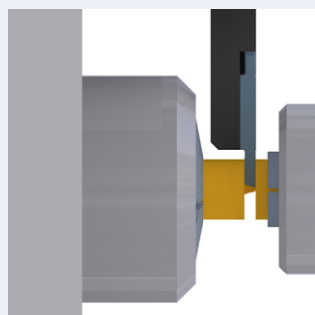

contre-broche
Gegenspindel
subspindle

Utiliser des porte-outils série 760,
voir page 1.43

Halter Serie 760 verwenden,
siehe Seite 1.43

Use 760 series holders,
see page 1.43

coupe à droite déportée
versetztes Rechtsschneiden
right cut off line

contre-broche
Gegenspindel
subspindle

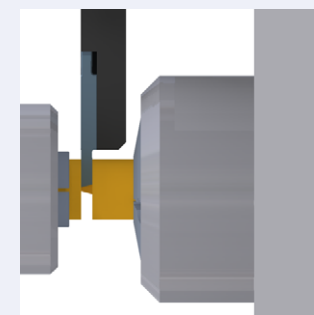

broche principale
Hauptspindel
Mainspindle

Utiliser des porte-outils série 750,
voir page 1.42

Halter Serie 750 verwenden,
siehe Seite 1.42

Use 750 series holders,
see page 1.42



tronçonnage
abstechen
parting off

761L

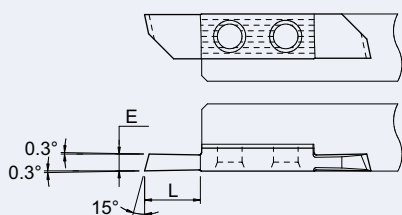

E	L	Art. N°	TIN	TIALN	N (µK20)	HTIN	HTA	HN (µK10)
1.0	5	761L-1.0	■	■	■	□	□	□
1.5	7.5	761L-1.5	■	■	■	□	□	□
1.8	7.5	761L-1.8	■	■	■	□	□	□
2.0	10	761L-2.0	■	■	■	■	■	■
2.2	10	761L-2.2	■	■	■	□	□	□
2.5	10	761L-2.5	■	■	■	□	□	□
3.0	10	761L-3.0	■	■	■	□	□	□

1.0	5.5	761Ls-1.0	■	■	■	□	□	□
1.5	8	761Ls-1.5	■	■	■	□	□	□
2.0	11.5	761Ls-2.0	■	■	■	□	□	□
2.2	11.5	761Ls-2.2	■	■	■	□	□	□
2.5	11.5	761Ls-2.5	■	■	■	□	□	□
3.0	11.5	761Ls-3.0	■	■	■	□	□	□

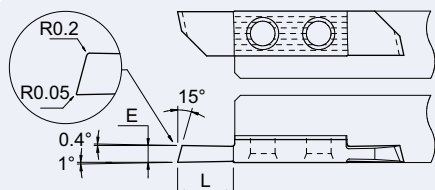

1.5	7.5	761L-1.5-R05	■	■	■	□	□	□
2.0	10	761L-2.0-R05	■	■	■	□	□	□

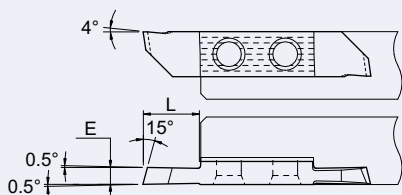

2.0	10	761Lx4-2.0	■	■	■	□	□	□
-----	----	------------	---	---	---	---	---	---

■ = Disponible / Verfügbar / Available
□ = Avec délai de livraison / Mit Lieferfrist / Available with delivery time

tronçonnage
abstechen
parting off

751R

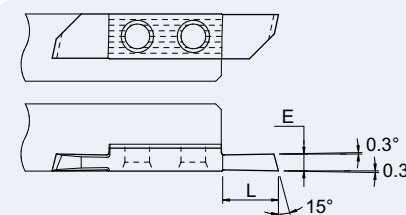

E	L	Art. N°	TIN	TIALN	N (µK20)	HTIN	HTA	HN (µK10)
1.0	5	751R-1.0	■	■	■	□	□	□
1.5	7.5	751R-1.5	■	■	■	□	■	■
1.8	7.5	751R-1.8	■	■	■	□	□	□
2.0	10	751R-2.0	■	■	■	■	■	■
2.2	10	751R-2.2	■	■	■	□	□	□
2.5	10	751R-2.5	■	■	■	□	□	□
3.0	10	751R-3.0	■	■	■	□	□	□

1.0	5.5	751Rs-1.0	■	■	■	□	□	□
1.5	8	751Rs-1.5	■	■	■	□	□	□
2.0	11.5	751Rs-2.0	■	■	■	■	■	■
2.2	11.5	751Rs-2.2	■	■	■	□	□	□
2.5	11.5	751Rs-2.5	■	■	■	□	□	□
3.0	11.5	751Rs-3.0	■	■	■	□	□	□

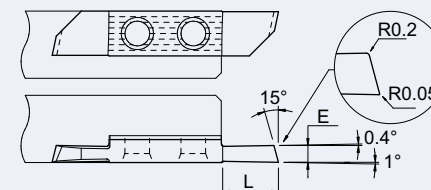

1.5	7.5	751R-1.5-R05	■	■	■	□	□	□
2.0	10	751R-2.0-R05	■	■	■	□	□	□

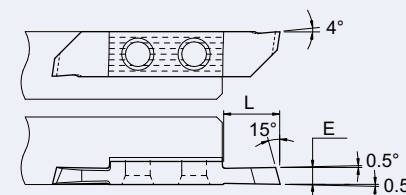

1.5	7.5	751Rx4-1.5	■	■	■	□	□	□
2.0	10	751Rx4-2.0	■	■	■	□	□	□
2.5	10	751Rx4-2.5	■	■	■	□	□	□

■ = Disponible / Verfügbar / Available
□ = Avec délai de livraison / Mit Lieferfrist / Available with delivery time

coupe à gauche déportée
versetztes Linksschneiden
left cut off line

broche principale
Hauptspindel
Mainspindle

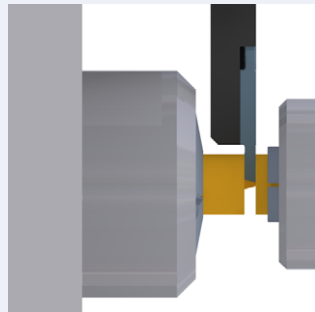

contre-broche
Gegenspindel
subspindle

Utiliser des porte-outils série 760,
voir page 1.43

Halter Serie 760 verwenden,
siehe Seite 1.43

Use 760 series holders,
see page 1.43

coupe à droite déportée
versetztes Rechtsschneiden
right cut off line

contre-broche
Gegenspindel
subspindle

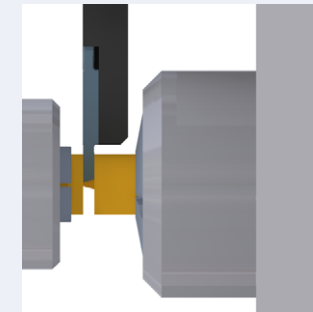

broche principale
Hauptspindel
Mainspindle

Utiliser des porte-outils série 750,
voir page 1.42

Halter Serie 750 verwenden,
siehe Seite 1.42

Use 750 series holders,
see pages 1.42



tronçonnage
abstechen
parting off

761L

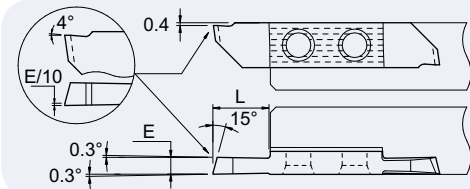

E	L	Art. N°	TiN	TiAlN	N (µK20)	HTiN	HTA	HN (µK10)
2.0	10	761Lxf-2.0	■	■	■	□	□	□
2.5	10	761Lxf-2.5	■	■	■	□	□	□
3.0	10	761Lxf-3.0	■	■	■	□	□	□

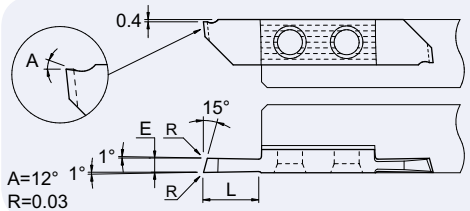

2.0	10	761Lx12-2.0	■	■	■	□	□	□
-----	----	-------------	---	---	---	---	---	---

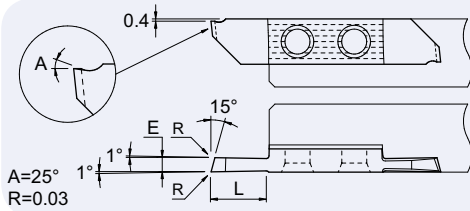

2.0	10	761Lx25-2.0	■	■	■	□	□	□
-----	----	-------------	---	---	---	---	---	---

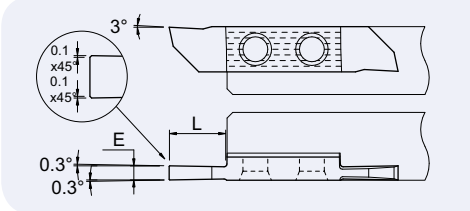

2.0	10	761nxf-2.0	■	■	■	□	□	□
2.5	10	761nxf-2.5	■	■	■	□	□	□
3.0	10	761nxf-3.0	■	■	■	□	□	□

■ = Disponible / Verfügbar / Available
□ = Avec délai de livraison / Mit Lieferfrist / Available with delivery time

751R

tronçonnage
abstechen
parting off

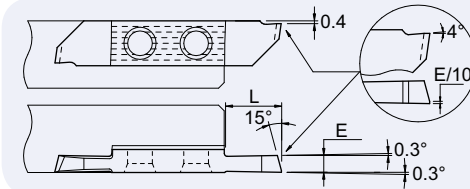

E	L	Art. N°	TiN	TiAlN	N (µK20)	HTiN	HTA	HN (µK10)
1.5	7.5	751Rxf-1.5	■	■	■	□	■	■
2.0	10	751Rxf-2.0	■	■	■	□	■	■
2.5	10	751Rxf-2.5	■	■	■	□	■	■
3.0	10	751Rxf-3.0	■	■	■	□	■	■

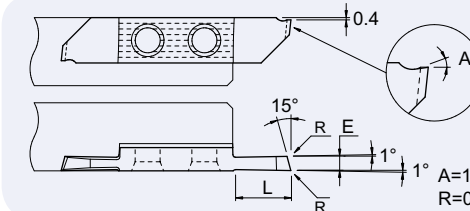

1.5	7.5	751Rx12-1.5	■	■	■	□	■	■
2.0	10	751Rx12-2.0	■	■	■	□	■	■

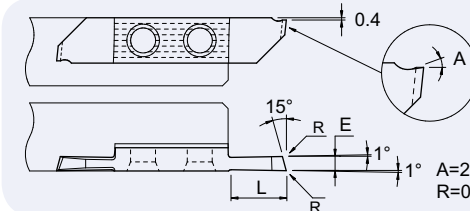

2.0	10	751Rx25-2.0	■	■	■	□	■	■
-----	----	-------------	---	---	---	---	---	---

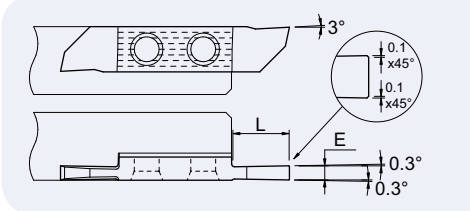

2.0	10	751nxf-2.0	■	■	■	□	■	■
2.5	10	751nxf-2.5	■	■	■	□	■	■
3.0	10	751nxf-3.0	■	■	■	□	■	■

■ = Disponible / Verfügbar / Available
□ = Avec délai de livraison / Mit Lieferfrist / Available with delivery time



tourneur avant
vorwärts drehen
front turning

752

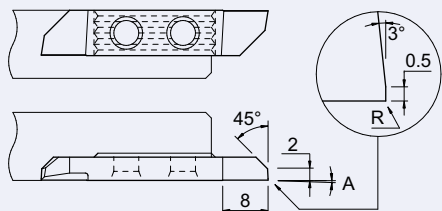

A	R	Art. N°	TIN	TIALN	N (µK20)	HTIN	HTA	HN (µK10)
0°	0	752	■	■	■	□	■	■
3°	0	752-3°	■	■	■	□	□	□

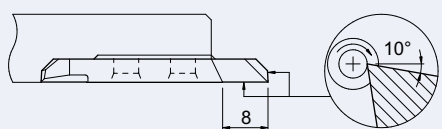

0°	0	752x	■	■	■	□	■	■
0°	0.2	752x-R20	■	■	■	□	□	□

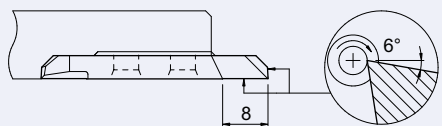

0°	0	752Px	■	■	■	□	□	□
----	---	-------	---	---	---	---	---	---



tourneur multifonction
Mehrzweck Dreher
multifunction turning

752S/753S

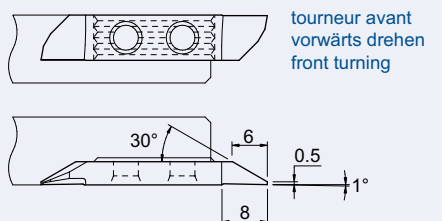

Art. N°	TIN	TIALN	N (µK20)	HTIN	HTA	HN (µK10)
752s05	■	■	■	□	■	■

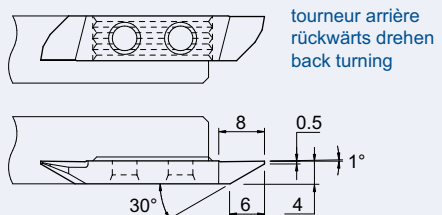

753s05	■	■	■	□	■	■
--------	---	---	---	---	---	---

7XX-XX-B



Sur demande pour serrage type B, voir page 1.02
Wahlweise für B-Spannsystem, siehe Seite 1.02
On request for B clamping system, see page 1.02

■ = Disponible / Verfügbar / Available
□ = Avec délai de livraison / Mit Lieferfrist
Available with delivery time

762

tourneur avant
vorwärts drehen
front turning

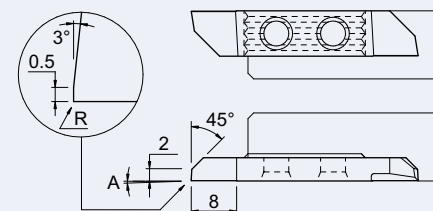

A	R	Art. N°	TIN	TIALN	N (µK20)	HTIN	HTA	HN (µK10)
0°	0	762	■	■	■	□	■	■
0°	0.2	762-R20	■	■	■	□	□	□
3°	0	762-3°	■	■	■	□	■	■

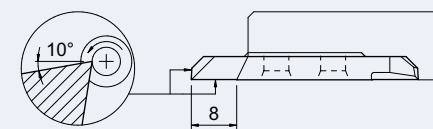

0°	0	762x	■	■	■	□	■	■
0°	0.2	762x-R20	■	■	■	□	□	□

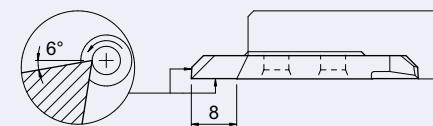

0°	0	762Px	■	■	■	□	□	□
----	---	-------	---	---	---	---	---	---

762S/763S

tourneur multifonction
Mehrzweck Dreher
multifunction turning



tourneur avant
vorwärts drehen
front turning

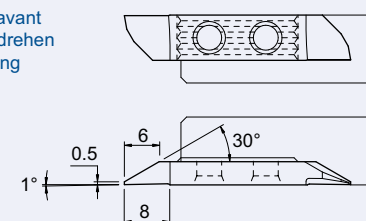

Art. N°	TIN	TIALN	N (µK20)	HTIN	HTA	HN (µK10)
762s05	■	■	■	□	■	■

tourneur arrière
rückwärts drehen
back turning

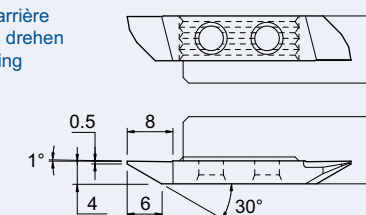

763s05	■	■	■	□	■	■
--------	---	---	---	---	---	---

7XX-XX-B



Sur demande pour serrage type B, voir page 1.02
Wahlweise für B-Spannsystem, siehe Seite 1.02
On request for B clamping system, see page 1.02

■ = Disponible / Verfügbar / Available
□ = Avec délai de livraison / Mit Lieferfrist
Available with delivery time



tourneur arrière / pré-coupe
rückwärts drehen / vorstechen
back turning / pre-parting off

753P

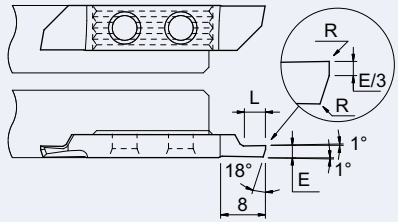

E	L	R	Art. N°	TIN	TIALN	N (µK20)	HTIN	HTA	HN (µK10)
1.5	3	0	753P-1.5	■	■	■	□	□	□
1.8	3.5	0	753P-1.8	■	■	■	□	□	□
2.0	4	0	753P-2.0	■	■	■	□	□	□
2.2	4.5	0	753P-2.2	■	■	■	□	□	□
2.5	5	0	753P-2.5	■	■	■	□	□	□
3.0	6	0	753P-3.0	■	■	■	□	□	□



tourneur arrière / pré-coupe
rückwärts drehen / vorstechen
back turning / pre-parting off

763P

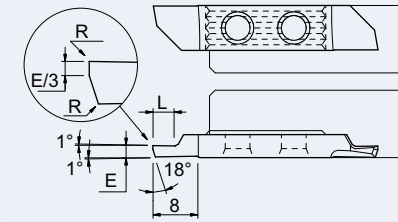

E	L	R	Art. N°	TIN	TIALN	N (µK20)	HTIN	HTA	HN (µK10)
1.5	3	0	763P-1.5	■	■	■	□	□	□
1.8	3.5	0	763P-1.8	■	■	■	□	□	□
2.0	4	0	763P-2.0	■	■	■	□	□	□
2.2	4.5	0	763P-2.2	■	■	■	□	□	□
2.5	5	0	763P-2.5	■	■	■	□	□	□
3.0	6	0	763P-3.0	■	■	■	□	□	□



tourneur arrière
rückwärts drehen
back turning

753

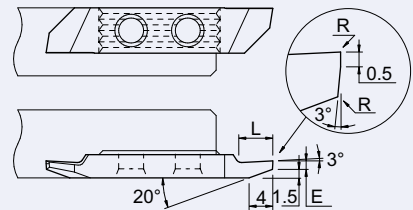

E	L	R	Art. N°	TIN	TIALN	N (µK20)	HTIN	HTA	HN (µK10)
1.0	5	0	753-1.0	■	■	■	□	□	□
1.0	5	0.08	753-1.0-R08	■	■	■	□	□	□
1.5	6	0	753-1.5	■	■	■	□	□	□
2.0	7.5	0	753-2.0	■	■	■	□	□	□
2.5	9	0	753-2.5	■	■	■	□	□	□

763

tourneur arrière
rückwärts drehen
back turning

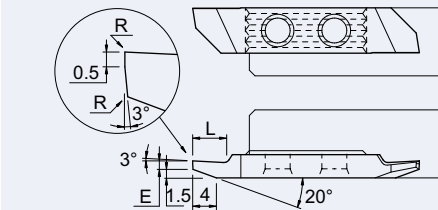

E	L	R	Art. N°	TIN	TIALN	N (µK20)	HTIN	HTA	HN (µK10)
1.0	5	0	763-1.0	■	■	■	■	■	■
1.0	5	0.08	763-1.0-R08	■	■	■	□	□	■
1.5	6	0	763-1.5	■	■	■	□	□	■
2.0	7.5	0	763-2.0	■	■	■	□	□	□
2.5	9	0	763-2.5	■	■	■	□	□	□

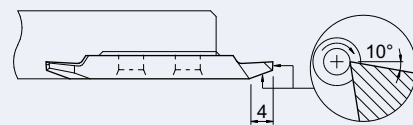

1.0	5	0	753x-1.0	■	■	■	□	□	□
1.0	5	0.08	753x-1.0-R08	■	■	■	□	□	□
1.0	5	0.2	753x-1.0-R20	■	■	■	□	□	□
1.5	6	0	753x-1.5	■	■	■	□	□	□
1.5	6	0.2	753x-1.5-R20	■	■	■	□	□	□
2.0	7.5	0	753x-2.0	■	■	■	□	□	□
2.0	7.5	0.2	753x-2.0-R20	■	■	■	□	□	□
2.5	9	0	753x-2.5	■	■	■	□	□	□
2.5	9	0.2	753x-2.5-R20	■	■	■	□	□	□

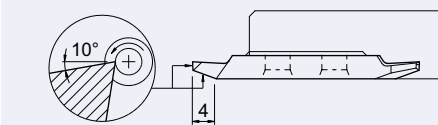

1.0	5	0	763x-1.0	■	■	■	□	□	■
1.0	5	0.08	763x-1.0-R08	■	■	■	□	□	■
1.0	5	0.2	763x-1.0-R20	■	■	■	□	□	□
1.5	6	0	763x-1.5	■	■	■	□	□	■
1.5	6	0.2	763x-1.5-R20	■	■	■	□	□	□
2.0	7.5	0	763x-2.0	■	■	■	□	□	□
2.0	7.5	0.2	763x-2.0-R20	■	■	■	□	□	□
2.5	9	0	763x-2.5	■	■	■	□	□	□
2.5	9	0.2	763x-2.5-R20	■	■	■	□	□	□

tourneur arrière pour passe profonde
rückwärts drehen für grosse Schnitttiefen
back turning for deep cut

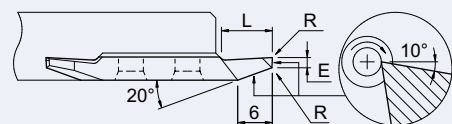

1.8	9	0	753xs-1.8	■	■	■	□	□	□
1.8	9	0.2	753xs-1.8-R20	■	■	■	□	□	□

tourneur arrière pour passe profonde
rückwärts drehen für grosse Schnitttiefen
back turning for deep cut

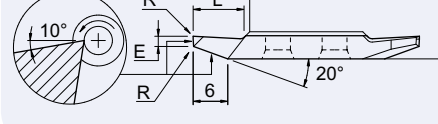

1.8	9	0	763xs-1.8	■	■	■	□	□	□
1.8	9	0.2	763xs-1.8-R20	■	■	■	□	□	□

7XX-XX-B



Sur demande pour serrage type B, voir page 1.02
Wahlweise für B-Spannsystem, siehe Seite 1.02
On request for B clamping system, see page 1.02

■ = Disponible / Verfügbar / Available
□ = Avec délai de livraison / Mit Lieferfrist
Available with delivery time

7XX-XX-B



Sur demande pour serrage type B, voir page 1.02
Wahlweise für B-Spannsystem, siehe Seite 1.02
On request for B clamping system, see page 1.02

■ = Disponible / Verfügbar / Available
□ = Avec délai de livraison / Mit Lieferfrist
Available with delivery time



tourneur arrière
rückwärts drehen
back turning

753

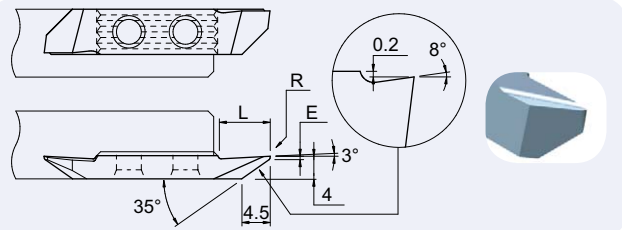

E	L	R	Art. N°	TIN	TIALN	N (µK20)	HTIN	HTA	HN (µK10)
~1.0	9	0	753vx-8°	■	■	■	□	□	□
~1.0	9	0.08	753vx-8°-R08	■	■	■	□	□	□

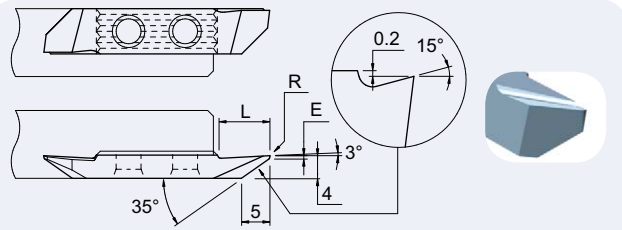

E	L	R	Art. N°	TIN	TIALN	N (µK20)	HTIN	HTA	HN (µK10)
0.6	9	0	753vx-15°	■	■	■	□	□	□
0.6	9	0.08	753vx-15°-R08	■	■	■	□	□	□

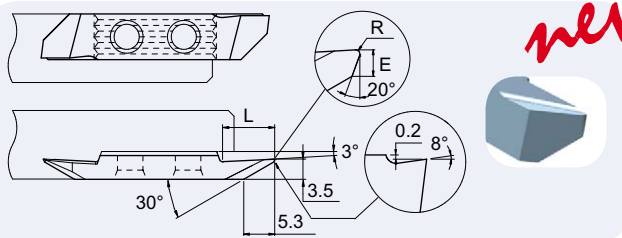

E	L	R	Art. N°	TIN	TIALN	N (µK20)	HTIN	HTA	HN (µK10)
0.5	9	0.08	753vx-805-R08	■	■	■	□	□	■

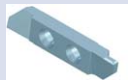

pour un meilleur contrôle des copeaux
für eine bessere Spankontrolle
for a better chip-control

ZX-Geometry

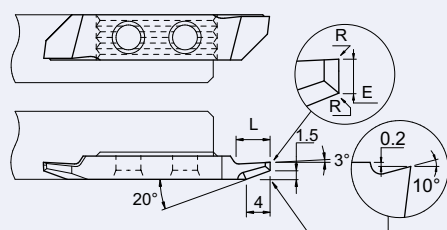

E	R	L	Art. N°	TIN	TIALN	N (µK20)
1.0	0.01	5	753zx10-1.0	□	■	■

autres géométries possibles
sur demande

andere Spangeometrien auf
Anfrage möglich

other cutting geometries
also possible on request

new



avance minimale 0.02 mm
für Vorschub ab 0.02 mm
for Feed from 0.02 mm

7XX-XX-B



Sur demande pour serrage type B, voir page 1.02
Wahlweise für B-Spannsystem, siehe Seite 1.02
On request for B clamping system, see page 1.02

■ = Disponible / Verfügbar / Available
□ = Avec délai de livraison / Mit Lieferfrist
Available with delivery time

763

tourneur arrière
rückwärts drehen
back turning

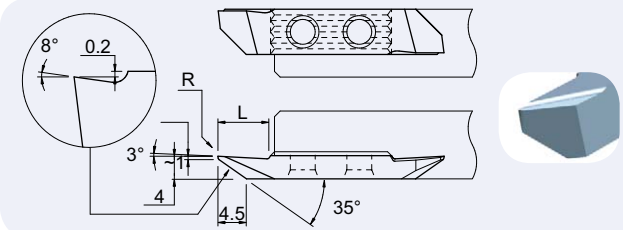

E	L	R	Art. N°	TIN	TIALN	N (µK20)	HTIN	HTA	HN (µK10)
~1.0	9	0	763vx-8°	■	■	■	■	■	■
~1.0	9	0.08	763vx-8°-R08	■	■	■	□	□	□

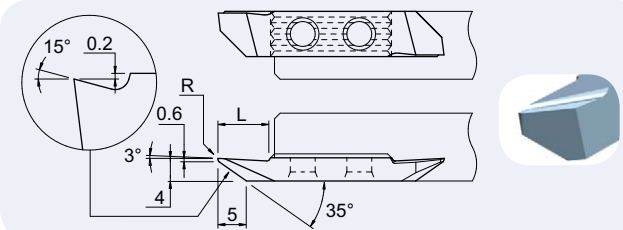

E	L	R	Art. N°	TIN	TIALN	N (µK20)	HTIN	HTA	HN (µK10)
0.6	9	0	763vx-15°	■	■	■	□	□	□
0.6	9	0.08	763vx-15°-R08	■	■	■	□	□	□

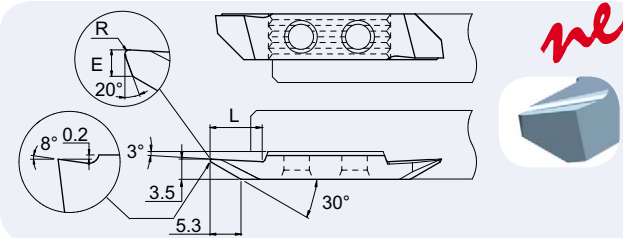

E	L	R	Art. N°	TIN	TIALN	N (µK20)	HTIN	HTA	HN (µK10)
0.5	9	0.08	763vx-805-R08	■	■	■	□	□	■

ZX-Geometry

pour un meilleur contrôle des copeaux
für eine bessere Spankontrolle
for a better chip-control

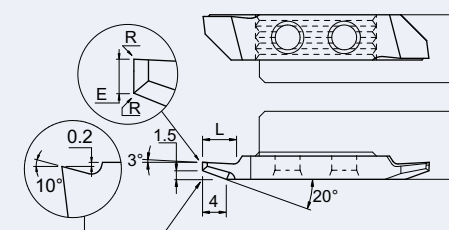

E	R	L	Art. N°	TIN	TIALN	N (µK20)
1.0	0.01	5	763zx10-1.0	□	■	■

autres géométries possibles
sur demande

andere Spangeometrien auf
Anfrage möglich

other cutting geometries
also possible on request

new



avance minimale 0.02 mm
für Vorschub ab 0.02 mm
for Feed from 0.02 mm

7XX-XX-B



Sur demande pour serrage type B, voir page 1.02
Wahlweise für B-Spannsystem, siehe Seite 1.02
On request for B clamping system, see page 1.02

■ = Disponible / Verfügbar / Available
□ = Avec délai de livraison / Mit Lieferfrist
Available with delivery time



foncer tourner
einstechen und drehen
grooving and turning

754

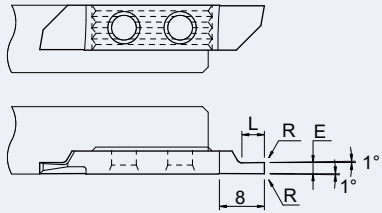

E	L	R	Art. N°	TIN	TIALN	N (µK20)	HTIN	HTA	HN (µK10)
0.5	1.5	0	754-0.5	■	■	■	□	□	□
0.75	2	0	754-0.75	■	■	■	□	□	□
0.95	3	0	754-0.95	■	■	■	□	□	□
1.0	2.5	0	754-1.0	■	■	■	□	□	□
1.0	2.5	0.08	754-1.0-R08	■	■	■	□	□	□
1.2	3	0	754-1.2	■	■	■	□	□	□
1.5	3	0	754-1.5	■	■	■	□	■	■
1.5	3	0.08	754-1.5-R08	■	■	■	□	■	■
1.8	4	0	754-1.8	■	■	■	□	□	□
2.0	4	0	754-2.0	■	■	■	□	■	■
2.0	4	0.08	754-2.0-R08	■	■	■	□	■	■
2.0	4	0.2	754-2.0-R20	■	■	■	□	□	□
2.5	6	0	754-2.5	■	■	■	□	□	□
3.0	6	0	754-3.0	■	■	■	□	□	□
3.0	6	0.08	754-3.0-R08	■	■	■	□	□	□
3.0	6	0.2	754-3.0-R20	■	■	■	□	□	□
4.0	8	0	754-4.0	■	■	■	□	□	□

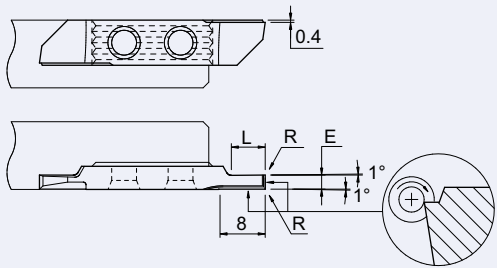

1.0	2	0	754vs-1.0	■	■	■	□	□	□
1.2	2.5	0	754vs-1.2	■	■	■	□	□	□
1.5	3	0	754vs-1.5	■	■	■	□	□	□
2.0	4	0	754vs-2.0	■	■	■	□	□	□
2.5	6	0	754vs-2.5	■	■	■	□	□	□
3.0	6	0	754vs-3.0	■	■	■	□	□	□

7XX-XX-B



Sur demande pour serrage type B, voir page 1.02
Wahlweise für B-Spannsystem, siehe Seite 1.02
On request for B clamping system, see page 1.02

■ = Disponible / Verfügbar / Available
□ = Avec délai de livraison / Mit Lieferfrist
Available with delivery time

764

foncer tourner
einstechen und drehen
grooving and turning

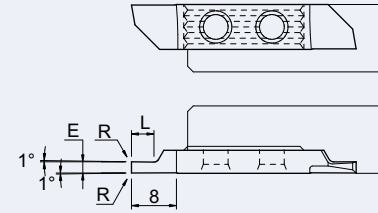

E	L	R	Art. N°	TIN	TIALN	N (µK20)	HTIN	HTA	HN (µK10)
0.5	1.5	0	764-0.5	■	■	■	□	□	□
0.75	2	0	764-0.75	■	■	■	□	□	□
0.8	2	0	764-0.8	■	■	■	□	□	□
0.95	3	0	764-0.95	■	■	■	□	□	□
1.0	2.5	0	764-1.0	■	■	■	□	□	□
1.0	2.5	0.08	764-1.0-R08	■	■	■	□	□	□
1.2	3	0	764-1.2	■	■	■	□	□	□
1.5	3	0	764-1.5	■	■	■	□	■	■
1.5	3	0.08	764-1.5-R08	■	■	■	□	■	■
1.5	3	0.2	764-1.5-R20	■	■	■	□	□	□
1.8	4	0	764-1.8	■	■	■	□	□	□
2.0	4	0	764-2.0	■	■	■	□	■	■
2.0	4	0.08	764-2.0-R08	■	■	■	□	■	■
2.0	4	0.2	764-2.0-R20	■	■	■	□	□	□
2.5	6	0	764-2.5	■	■	■	□	□	■
2.5	6	0.2	764-2.5-R20	■	■	■	□	□	□
3.0	6	0	764-3.0	■	■	■	□	□	□
3.0	6	0.08	764-3.0-R08	■	■	■	□	□	□
3.0	6	0.2	764-3.0-R20	■	■	■	□	□	□
4.0	8	0	764-4.0	■	■	■	□	□	□

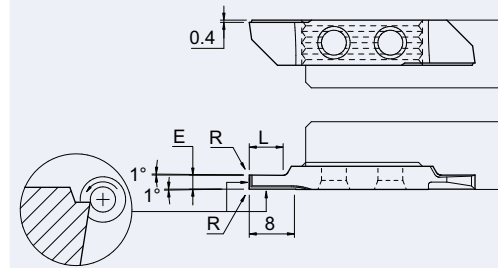

1.0	2	0	764vs-1.0	■	■	■	□	□	□
1.2	2.5	0	764vs-1.2	■	■	■	□	□	□
1.5	3	0	764vs-1.5	■	■	■	□	□	□
2.0	4	0	764vs-2.0	■	■	■	□	□	□
2.5	6	0	764vs-2.5	■	■	■	□	□	□
3.0	6	0	764vs-3.0	■	■	■	□	□	□

7XX-XX-B



Sur demande pour serrage type B, voir page 1.02
Wahlweise für B-Spannsystem, siehe Seite 1.02
On request for B clamping system, see page 1.02

■ = Disponible / Verfügbar / Available
□ = Avec délai de livraison / Mit Lieferfrist
Available with delivery time



fonder tourner
einstechen und drehen
grooving and turning

754

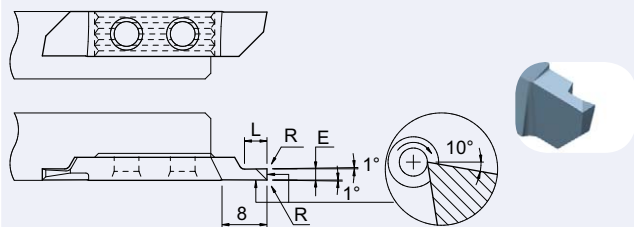

E	L	R	Art. N°	TIN	TIALN	N (µK20)	HTIN	HTA	HN (µK10)
1.0	2.5	0	754x-1.0	■	■	■	■	■	■
1.0	2.5	0.08	754x-1.0-R08	■	■	■	□	■	■
1.2	3	0	754x-1.2	■	■	■	□	□	□
1.5	3	0	754x-1.5	■	■	■	□	■	■
1.5	3	0.08	754x-1.5-R08	■	■	■	□	■	■
1.5	3	0.2	754x-1.5-R20	■	■	■	□	□	□
1.8	4	0	754x-1.8	■	■	■	□	□	□
2.0	4	0	754x-2.0	■	■	■	□	■	■
2.0	4	0.08	754x-2.0-R08	■	■	■	□	■	■
2.0	4	0.2	754x-2.0-R20	■	■	■	□	□	□
2.5	6	0	754x-2.5	■	■	■	□	■	■
2.5	6	0.2	754x-2.5-R20	■	■	■	□	□	□
3.0	6	0	754x-3.0	■	■	■	□	□	□
3.0	6	0.08	754x-3.0-R08	■	■	■	□	□	□
3.0	6	0.2	754x-3.0-R20	■	■	■	□	□	□
4.0	8	0	754x-4.0	■	■	■	□	□	□
4.0	8	0.2	754x-4.0-R20	■	■	■	□	□	□



fonder tourner
einstechen und drehen
grooving and turning

764

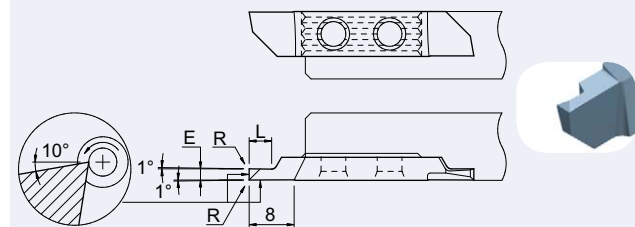

E	L	R	Art. N°	TIN	TIALN	N (µK20)	HTIN	HTA	HN (µK10)
1.0	2.5	0	764x-1.0	■	■	■	□	■	■
1.0	2.5	0.08	764x-1.0-R08	■	■	■	□	■	■
1.2	3	0	764x-1.2	■	■	■	□	□	□
1.5	3	0	764x-1.5	■	■	■	□	■	■
1.5	3	0.08	764x-1.5-R08	■	■	■	□	■	■
1.5	3	0.2	764x-1.5-R20	■	■	■	□	□	□
1.8	4	0	764x-1.8	■	■	■	□	□	□
2.0	4	0	764x-2.0	■	■	■	□	■	■
2.0	4	0.08	764x-2.0-R08	■	■	■	□	■	■
2.0	4	0.2	764x-2.0-R20	■	■	■	□	□	□
2.5	6	0	764x-2.5	■	■	■	□	■	■
2.5	6	0.2	764x-2.5-R20	■	■	■	□	□	□
3.0	6	0	764x-3.0	■	■	■	□	□	□
3.0	6	0.08	764x-3.0-R08	■	■	■	□	□	□
3.0	6	0.2	764x-3.0-R20	■	■	■	□	□	□
4.0	8	0	764x-4.0	■	■	■	□	□	□
4.0	8	0.2	764x-4.0-R20	■	■	■	□	□	□



pour un meilleur contrôle des copeaux
für einen besseren Spankontrolle
for better chip-control

ZX-Geometry

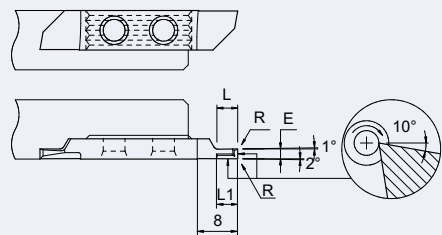

E	L	L1	R	Art. N°	TIN	TIALN	N (µK20)
1.5	4	4	0.03	754zx10-1.5-R03	□	■	
1.5	4	4	0.08	754zx10-1.5-R08	□	■	
2.0	4	4	0.08	754zx10-2.0-R08	□	■	
2.5	5	5	0.08	754zx10-2.5-R08	□	■	
3.0	6	6	0.08	754zx10-3.0-R08	□	■	

avance minimale 0.02 mm
für Vorschub ab 0.02 mm
for Feed from 0.02 mm

ZX-Geometry

pour un meilleur contrôle des copeaux
für einen besseren Spankontrolle
for better chip-control

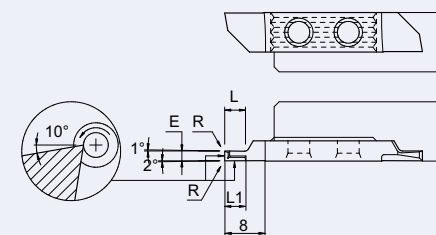

E	L	L1	R	Art. N°	TIN	TIALN	N (µK20)
1.5	4	4	0.03	764zx10-1.5-R03	□	■	
1.5	4	4	0.08	764zx10-1.5-R08	□	■	
2.0	4	4	0.08	764zx10-2.0-R08	□	■	
2.0	4	4	0.2	764zx10-2.0-R20	□	■	
2.5	5	5	0.08	764zx10-2.5-R08	□	■	
2.5	5	5	0.2	764zx10-2.5-R20	□	■	
3.0	6	6	0.08	764zx10-3.0-R08	□	■	
3.0	6	6	0.2	764zx10-3.0-R20	□	■	
4.0	6	6	0.2	764zx10-4.0-R20	□	■	

avance minimale 0.02 mm
für Vorschub ab 0.02 mm
for Feed from 0.02 mm

new



autres géométries possibles
sur demande

andere Spangeometrien
auch möglich auf Anfrage

other cutting geometries
also possible on request

7XX-XX-B



Sur demande pour serrage type B, voir page 1.02
Wahlweise für B-Spannsystem, siehe Seite 1.02
On request for B clamping system, see page 1.02

■ = Disponible / Verfügbar / Available
□ = Avec délai de livraison / Mit Lieferfrist
Available with delivery time

new



autres géométries possibles
sur demande

andere Spangeometrien
auch möglich auf Anfrage

other cutting geometries
also possible on request

7XX-XX-B



Sur demande pour serrage type B, voir page 1.02
Wahlweise für B-Spannsystem, siehe Seite 1.02
On request for B clamping system, see page 1.02

■ = Disponible / Verfügbar / Available
□ = Avec délai de livraison / Mit Lieferfrist
Available with delivery time



fileter
Gewinde drehen
threading

756

partial profile

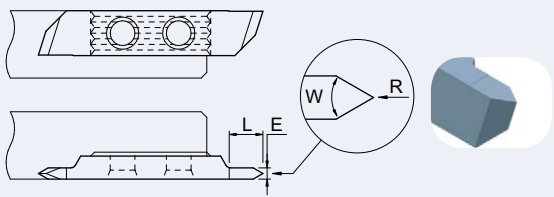

W	E	L	R	Art. N°	TIN	TIALN	N (µK20)	HTIN	HTALN	HN (µK10)
60°	2.0	6	0	756-60-2	■	■	■			
60°	2.0	6	0.02	756-60-2-R02	■	■	■	□	■	■
60°	3.0	8	0	756-60-3	■	■	■			
60°	3.0	8	0.02	756-60-3-R02	■	■	■	□	■	■
55°	2.0	6	0	756-55-2	■	■	■			
55°	3.0	8	0	756-55-3	■	■	■			

partial profile

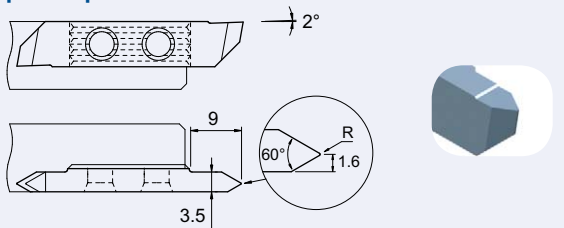

Pas Steigung Pitch	R	Art. N°	TIN	TIALN	N (µK20)	HTIN	HTALN	HN (µK10)
P	R	Art. N°	■	■	■	□	□	□
0.50-1.50	0.06	756-AG60°	■	■	■	□	□	□
1.75-3.00	0.2	756-G60°	■	■	■	□	□	□

full profile

ISO metric

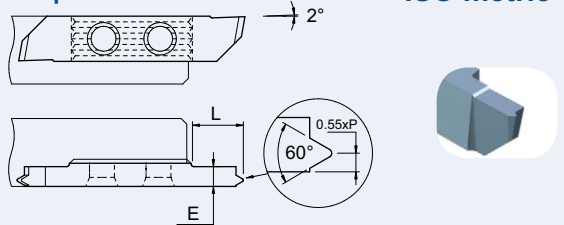

Pas Steigung Pitch	E	L	Art. N°	TIN	TIALN	N (µK20)	HTIN	HTALN	HN (µK10)
P	E	L	Art. N°	■	■	■			
0.80	2.5	8	756-M-0.80	■	■	■			
1.00	2.5	8	756-M-1.00	■	■	■			
1.25	2.5	8	756-M-1.25	■	■	■			
1.50	3.5	9	756-M-1.50	■	■	■			
1.75	3.5	9	756-M-1.75	■	■	■			
2.00	3.5	9	756-M-2.00	■	■	■			

Pour de plus petits pas,
voir série 736 à la page 1.40

Für kleinere Steigungen,
siehe Serie 736 auf Seite 1.40

For smaller pitch,
see series 736 on page 1.40

7XX-XX-B



Sur demande pour serrage type B, voir page 1.02
Wahlweise für B-Spannsystem, siehe Seite 1.02
On request for B clamping system, see page 1.02

■ = Disponible / Verfügbar / Available
□ = Avec délai de livraison / Mit Lieferfrist
Available with delivery time



fileter
Gewinde drehen
threading

766

partial profile

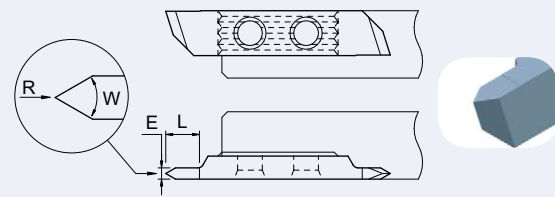

W	E	L	R	Art. N°	TIN	TIALN	N (µK20)	HTIN	HTA	HN (µK10)
60°	2.0	6	0	766-60-2	■	■	■			
60°	2.0	6	0.02	766-60-2-R02	■	■	■	□	■	■
60°	3.0	8	0	766-60-3	■	■	■			
60°	3.0	8	0.02	766-60-3-R02	■	■	■	□	■	■
55°	2.0	6	0	766-55-2	■	■	■			
55°	3.0	8	0	766-55-3	■	■	■			

partial profile

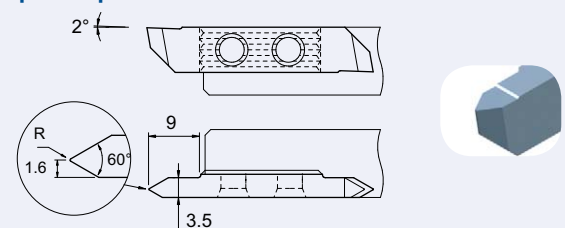

Pas Steigung Pitch	R	Art. N°	TIN	TIALN	N (µK20)	HTIN	HTA	HN (µK10)
P	R	Art. N°	■	■	■	□	□	□
0.50-1.50	0.06	766-AG60°	■	■	■	□	□	□
1.75-3.00	0.2	766-G60°	■	■	■	□	□	□

full profile

ISO metric

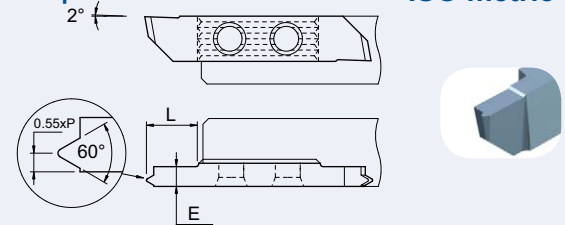

Pas Steigung Pitch	E	L	Art. N°	TIN	TIALN	N (µK20)	HTIN	HTA	HN (µK10)
P	E	L	Art. N°	■	■	■			
0.80	2.5	8	766-M-0.80	■	■	■			
1.00	2.5	8	766-M-1.00	■	■	■			
1.25	2.5	8	766-M-1.25	■	■	■			
1.50	3.5	9	766-M-1.50	■	■	■			
1.75	3.5	9	766-M-1.75	■	■	■			
2.00	3.5	9	766-M-2.00	■	■	■			

Pour de plus petits pas,
voir série 746 à la page 1.41

Für kleinere Steigungen,
siehe Serie 746 auf Seite 1.41

For smaller pitch,
see series 746 on page 1.41

7XX-XX-B



Sur demande pour serrage type B, voir page 1.02
Wahlweise für B-Spannsystem, siehe Seite 1.02
On request for B clamping system, see page 1.02

■ = Disponible / Verfügbar / Available
□ = Avec délai de livraison / Mit Lieferfrist
Available with delivery time



plaquette à rayon
Radius-Wendeplatte
insert with radius

757

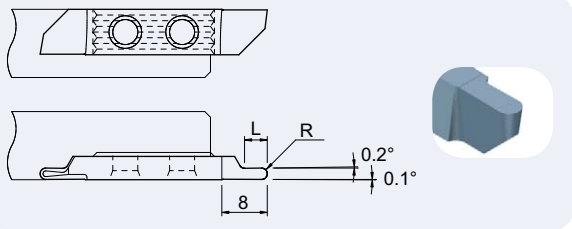

R	L	Art. N°	TIN TIALN N (µK20)	HTIN HTIALN HN (µK10)
0.5	2.5	757-R0.5	■ ■ ■	
1.0	4	757-R1.0	■ ■ ■	
1.5	6	757-R1.5	■ ■ ■	
2.0	8	757-R2.0	■ ■ ■	

767

plaquette à rayon
Radius-Wendeplatte
insert with radius

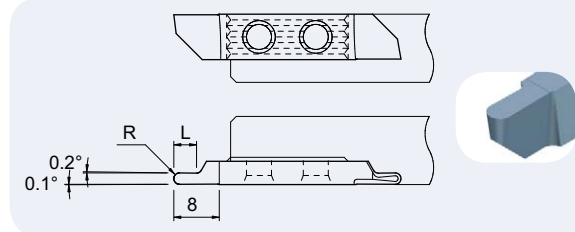

R	L	Art. N°	TIN TIALN N (µK20)	HTIN HTA HN (µK10)
0.5	2.5	767-R0.5	■ ■ ■	
1.0	4	767-R1.0	■ ■ ■	
1.5	6	767-R1.5	■ ■ ■	
2.0	8	767-R2.0	■ ■ ■	



pour un meilleur contrôle des copeaux
für eine bessere Spankontrolle
for better chip-control

ZX-Geometry

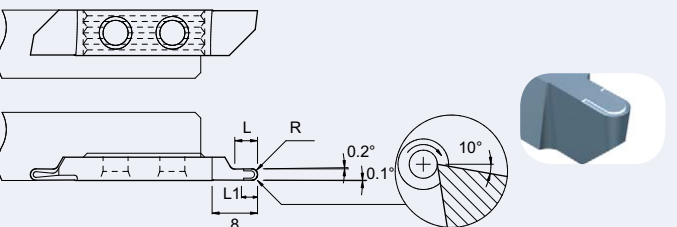

L	L1	R	Art. N°	TIN TIALN N (µK20)
4	3.5	1	757zx10-R1.0	□ ■
6	4	1.5	757zx10-R1.5	□ ■
8	4.5	2.0	757zx10-R2.0	□ ■

ZX-Geometry

pour un meilleur contrôle des copeaux
für eine bessere Spankontrolle
for better chip-control

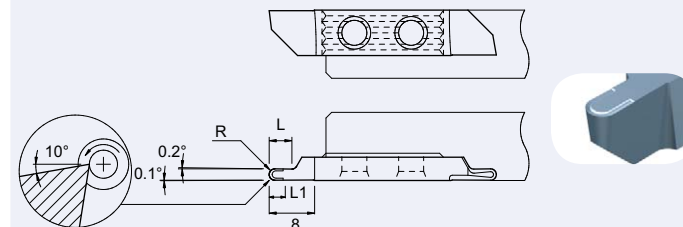

L	L1	R	Art. N°	TIN TIALN N (µK20)
4	3.5	1.0	767zx10-R1.0	□ ■
6	4	1.5	767zx10-R1.5	□ ■
8	4.5	2.0	767zx10-R2.0	□ ■

new



autres géométries possibles
sur demande

andere Spangeometrien
auch möglich auf Anfrage

other cutting geometries
also possible on request

new



autres géométries possibles
sur demande

andere Spangeometrien
auch möglich auf Anfrage

other cutting geometries
also possible on request



porte-outils
Halter
holders

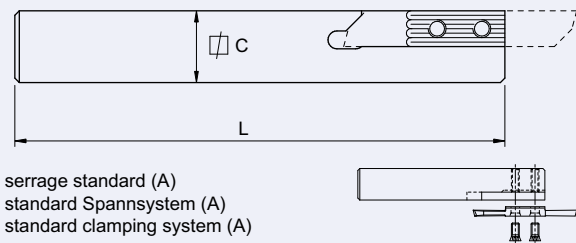

C	L	Art. N°
12 X 12	130	770-12
12 X 12	90	770-12-90
13 X 13	130	770-13
14 X 14	130	770-14
16 X 16	130	770-16
16 X 16	75	770-16-75
20 X 20	120	770-20
25 X 25	140	770-25



plaquette ébauche
VHM-Rohling
blank insert

771-E

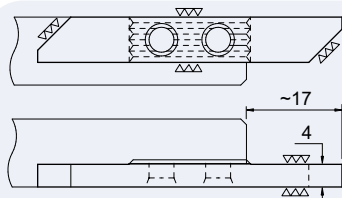
Art. N°
771-EN (µK20)
■

tronçonnage
abstechen
parting off

771

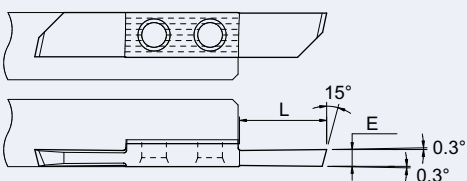

E	L	Art. N°	TIN TIALN N (µK20)
2.0	16	771-2.0	■ ■ ■
2.5	16	771-2.5	■ ■ ■
3.0	16	771-3.0	■ ■ ■
3.5	16	771-3.5	■ ■ ■

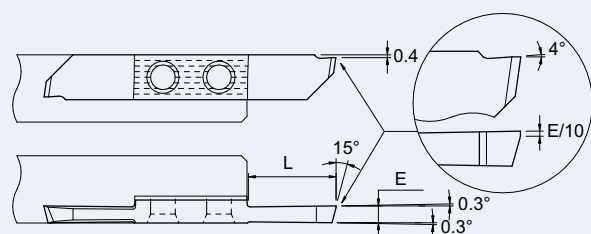

2.5	16	771xf-2.5	■ ■ ■
3.0	16	771xf-3.0	■ ■ ■
3.5	16	771xf-3.5	■ ■ ■

7XX-XX-B



Sur demande pour serrage type B, voir page 1.02
Wahlweise für B-Spannsystem, siehe Seite 1.02
On request for B clamping system, see page 1.02

■ = Disponible / Verfügbar / Available
□ = Avec délai de livraison / Mit Lieferfrist
Available with delivery time

porte-outils
Halter
holders

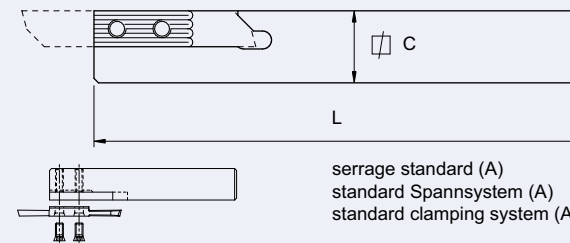

C	L	Art. N°
12 X 12	130	780-12
12 X 12	90	780-12-90
13 X 13	130	780-13
14 X 14	130	780-14
16 X 16	130	780-16
16 X 16	75	780-16-75
20 X 20	120	780-20
25 X 25	140	780-25

781-E

plaquette ébauche
VHM-Rohling
blank insert

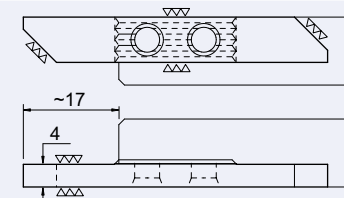
Art. N°
781-EN (µK20)
■

781

tronçonnage
abstechen
parting off

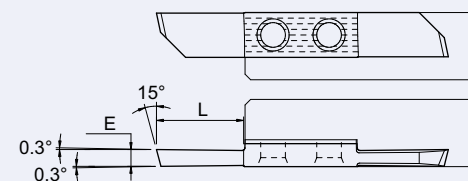

E	L	Art. N°	TIN TIALN N (µK20)
1.5	16	781-1.5	■ ■ ■
2.0	16	781-2.0	■ ■ ■
2.5	16	781-2.5	■ ■ ■
3.0	16	781-3.0	■ ■ ■
3.5	16	781-3.5	■ ■ ■

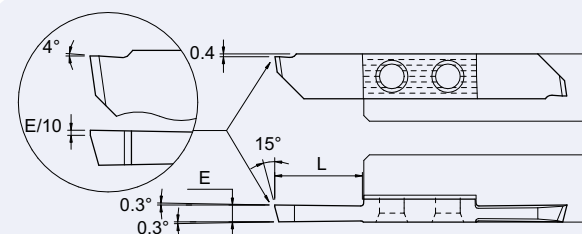

2.0	16	781xf-2.0	■ ■ ■
2.5	16	781xf-2.5	■ ■ ■
3.0	16	781xf-3.0	■ ■ ■
3.5	16	781xf-3.5	■ ■ ■

7XX-XX-B



Sur demande pour serrage type B, voir page 1.02
Wahlweise für B-Spannsystem, siehe Seite 1.02
On request for B clamping system, see page 1.02

■ = Disponible / Verfügbar / Available
□ = Avec délai de livraison / Mit Lieferfrist
Available with delivery time



coupe à gauche déportée
versetztes Linksschneiden
left cut off line

781L

broche principale
Hauptspindel

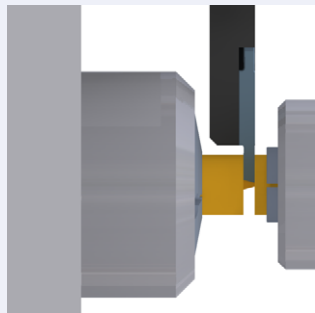

contre-broche
Gegenspindel
subspindle

Utiliser des porte-outils série 780.
(voir page 1.69)

Halter Serie 780 verwenden.
(siehe Seite 1.69)

Use 780 series holders.
(see page 1.69)

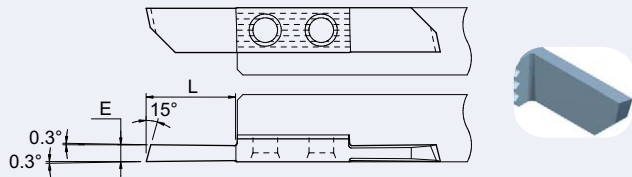

E	L	Art. N°	TIN	TIALN	N (µK20)
2.0	16	781L-2.0	■	■	■
2.5	16	781L-2.5	■	■	■
3.0	16	781L-3.0	■	■	■
3.5	16	781L-3.5	■	■	■

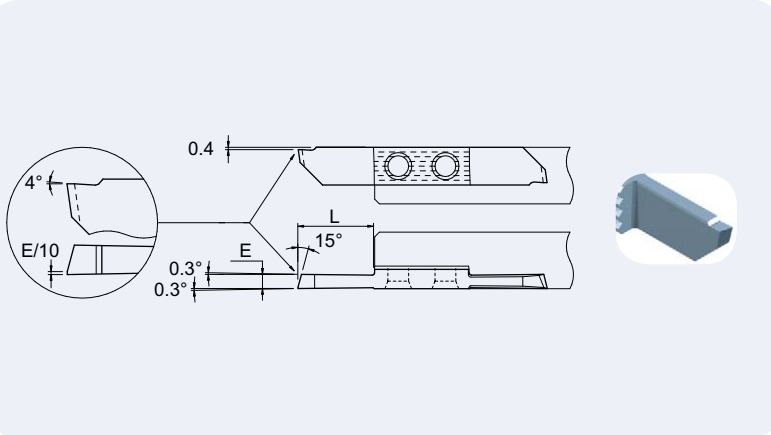

2.5	16	781Lxf-2.5	■	■	■
3.0	16	781Lxf-3.0	■	■	■
3.5	16	781Lxf-3.5	■	■	■

■ = Disponible / Verfügbar / Available
□ = Avec délai de livraison / Mit Lieferfrist / Available with delivery time



coupe à droite déportée
versetztes Rechtsschneiden
right cut off line

771R

contre-broche
Gegenspindel
subspindle

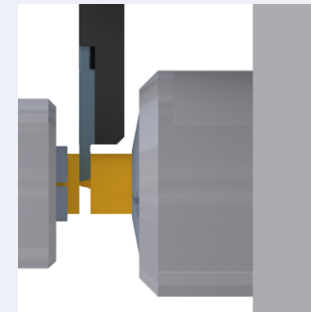

broche principale
Hauptspindel
Mainspindel

Utiliser des porte-outils série 770.
(voir page 1.68)

Halter Serie 770 verwenden.
(siehe Seite 1.68)

Use 770 series holders
(see page 1.68)

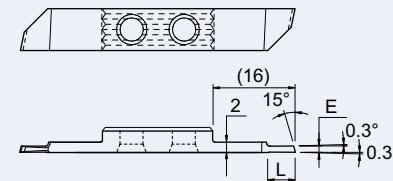

E	L	Art. N°	TIN	TIALN	N (µK20)
1.0	5	771R-1.0	■	■	■
1.2	5	771R-1.2	■	■	■
1.5	8.5	771R-1.5	■	■	■

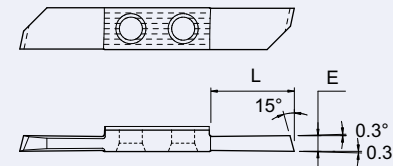

2.0	16	771R-2.0	■	■	■
2.5	16	771R-2.5	■	■	■
3.0	16	771R-3.0	■	■	■
3.5	16	771R-3.5	■	■	■

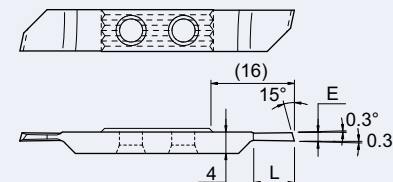

1.2	5	771RD-1.2	■	■	■
1.5	7.5	771RD-1.5	■	■	■
2.0	10	771RD-2.0	■	■	■

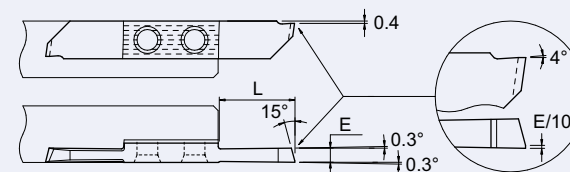

2.0	16	771Rxf-2.0	■	■	■
2.5	16	771Rxf-2.5	■	■	■
3.0	16	771Rxf-3.0	■	■	■
3.5	16	771Rxf-3.5	■	■	■

■ = Disponible / Verfügbar / Available
□ = Avec délai de livraison / Mit Lieferfrist / Available with delivery time

porte-outils
Halter
holders

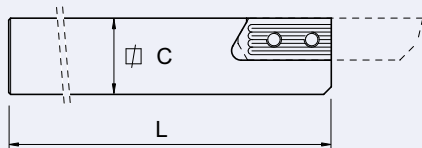

serrage standard (A)
standard Spannsystem (A)
standard clamping system (A)

C	L	Art. N°
16 X 16	130	7050-16
16 X 16	75	7050-16-75
20 X 20	120	7050-20
25 X 25	140	7050-25



plaquette ébauche
VHM-Rohling
blank insert

7051-E

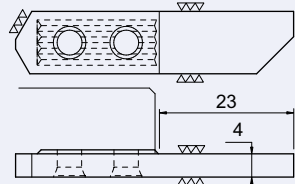

Art. N°	N (µK20)
7051-E	■



trouçonnage
abstechen
parting off

7051

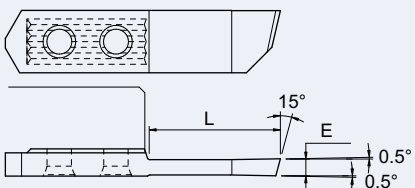

E	L	Art. N°	TIN	TIALN	N (µK20)
3.0	22	7051-3.0	■	■	■

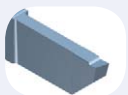
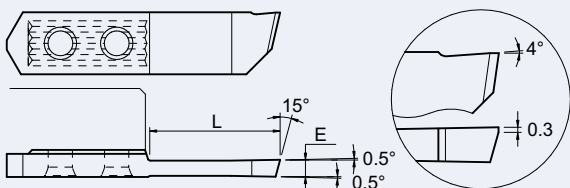

3.0	22	7051xf-3.0	■	■	■
-----	----	------------	---	---	---

■ = Disponible / Verfügbar / Available
□ = Avec délai de livraison / Mit Lieferfrist / Available with delivery time

porte-outils
Halter
holders

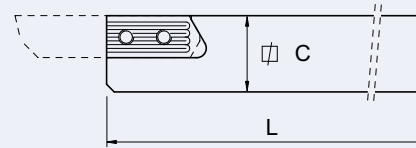

serrage standard (A)
standard Spannsystem (A)
standard clamping system (A)

C	L	Art. N°
16 X 16	130	7060-16
16 X 16	75	7060-16-75
20 X 20	120	7060-20
25 X 25	140	7060-25

7061-E

plaquette ébauche
VHM-Rohling
blank insert

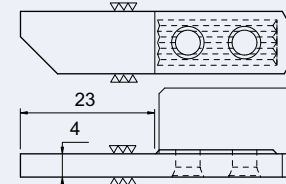

Art. N°	N (µK20)
7061-E	■

7061

trouçonnage
abstechen
parting off

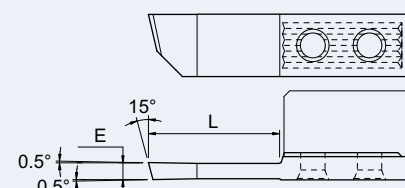

E	L	Art. N°	TIN	TIALN	N (µK20)
2.5	22	7061-2.5	■	■	■
3.0	22	7061-3.0	■	■	■
3.5	22	7061-3.5	■	■	■

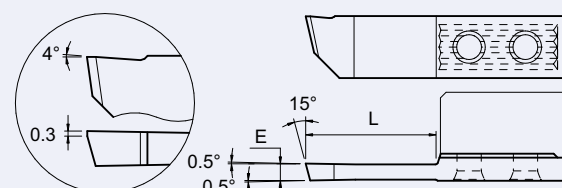

3.0	22	7061xf-3.0	■	■	■
-----	----	------------	---	---	---

■ = Disponible / Verfügbar / Available
□ = Avec délai de livraison / Mit Lieferfrist / Available with delivery time



coupe à gauche déportée
versetztes Linksschneiden
left cut off line

7061L

broche principale
Hauptspindel
main spindle

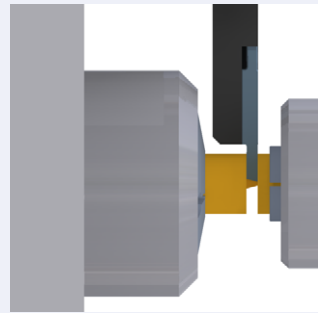

contre-broche
Gegenspindel
sub spindle

Utiliser des porte-outils série 7060.
(voir page 1.73)

Halter Serie 7060 verwenden.
(siehe Seite 1.73)

Use 7060 series holders.
(see page 1.73)

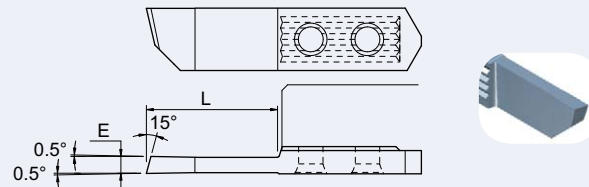

E	L	Art. N°	TIN	TIALN	N (µK20)
3.0	22	7061L-3.0	■	■	■

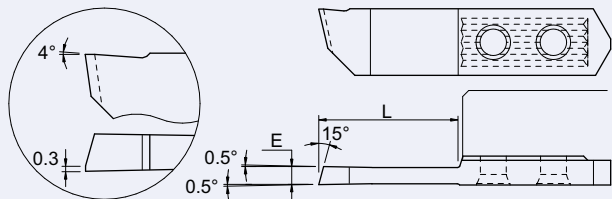

3.0	22	7061Lxf-3.0	■	■	■
-----	----	-------------	---	---	---



■ = Disponible / Verfügbar / Available
□ = Avec délai de livraison / Mit Lieferfrist / Available with delivery time



coupe à droite déportée
versetztes Rechtsschneiden
right cut off line

7051R

contre-broche
Gegenspindel
sub spindle

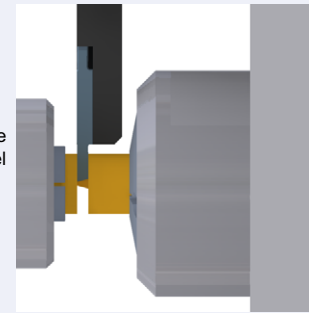

broche principale
Hauptspindel
main spindle

Utiliser des porte-outils série 7050.
(voir page 1.72)

Halter Serie 7050 verwenden.
(siehe Seite 1.72)

Use 7050 series holders.
(see page 1.72)

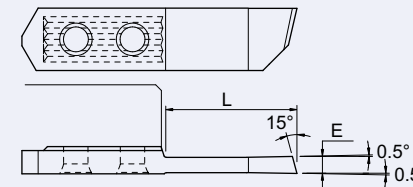

E	L	Art. N°	TIN	TIALN	N (µK20)
2.5	22	7051R-2.5	■	■	■
3.0	22	7051R-3.0	■	■	■
3.5	22	7051R-3.5	■	■	■

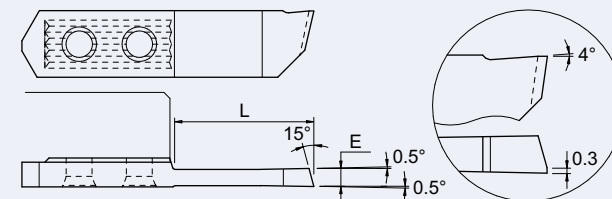

3.0	22	7051Rxf-3.0	■	■	■
-----	----	-------------	---	---	---



■ = Disponible / Verfügbar / Available
□ = Avec délai de livraison / Mit Lieferfrist / Available with delivery time

burin série 700 avec plaquette large
Drehwerkzeuge Serie 700 mit breiter Wendeplatte
turning tools series 700 with large insert

porte-outils
Halter
holders

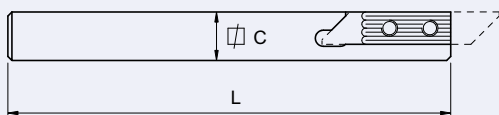

C	L	Art. N°
12 X 12	130	W750-12
16 X 16	130	W750-16
20 X 20	120	W750-20



plaquette ébauche
VHM-Rohling
blank insert

W751

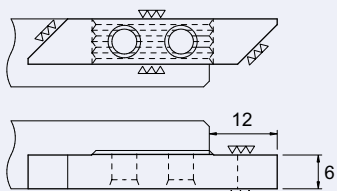

Art. N°	N (µK20)
W751-E6	■

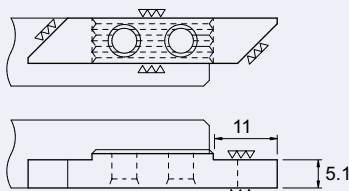

W751-E5	■
---------	---

■ = Disponible / Verfügbar / Available
□ = Avec délai de livraison / Mit Lieferfrist / Available with delivery time

burin série 700 avec plaquette large
Drehwerkzeuge Serie 700 mit breiter Wendeplatte
turning tools series 700 with large insert

porte-outils
Halter
holders

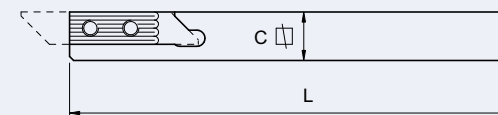

C	L	Art. N°
12 X 12	130	W760-12
16 X 16	130	W760-16
20 X 20	120	W760-20

W761

plaquette ébauche
VHM-Rohling
blank insert

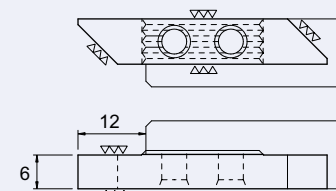

Art. N°	N (µK20)
W761-E6	■

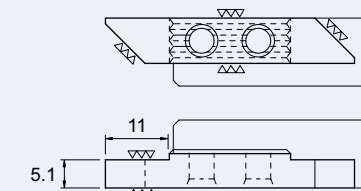

W761-E5	■
---------	---

■ = Disponible / Verfügbar / Available
□ = Avec délai de livraison / Mit Lieferfrist / Available with delivery time

Porte-outils spéciaux pour machine TORNOS DECO 7 / 10 mm
 Sonderhalter für TORNOS DECO 7 / 10 mm Maschine
 Special holders für TORNOS DECO 7 / 10 mm machine

L coupe à gauche
 Linksschneiden
 left hand cut

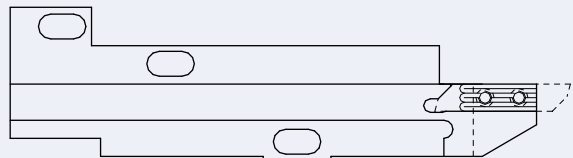

Art. N°
730-DECO10

A utiliser sur
 porte-outil TORNOS
 court à gauche

Auf TORNOS linken
 kurzen Werkzeughalter
 verwenden

To be used on
 TORNOS short
 tool holder left

TORNOS N° 305 078

utiliser des plaquettes série 730
 Wendeplatten Serie 730 verwenden
 use inserts series 730

voir page :
 siehe Seite : 1.26 - 1.40
 see page :

serrage standard (A) uniquement
 nur standard Spannsystem (A)
 standard clamping system (A) only

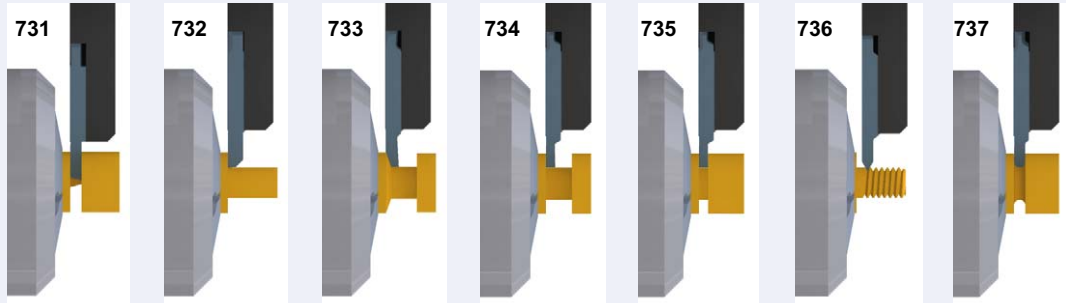

coupe à gauche déportée
 versetztes Linksschneiden
 left cut off line

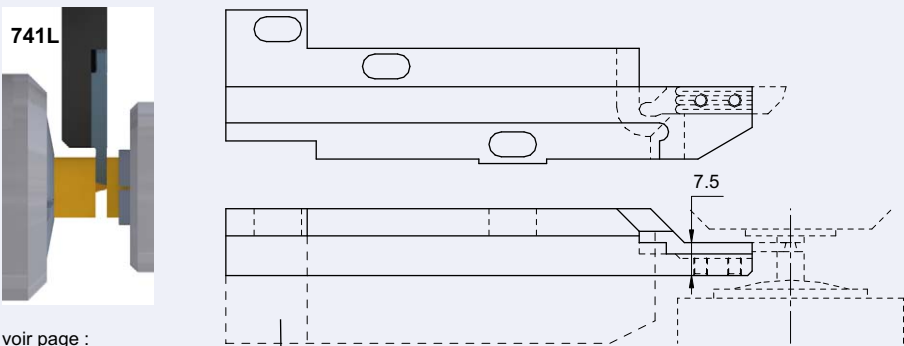

Art. N°
740L-DECO10

A utiliser sur
 porte-outil TORNOS
 court à gauche

Auf TORNOS linken
 kurzen Werkzeughalter
 verwenden

To be used on
 TORNOS short
 tool holder left

voir page :
 siehe Seite : 1.30
 see page :

TORNOS N° 305 078

Porte-outils spéciaux pour machine TORNOS DECO 7 / 10 mm
 Sonderhalter für TORNOS DECO 7 / 10 mm Maschine
 Special holders für TORNOS DECO 7 / 10 mm machine

R coupe à droite
 Rechtsschneiden
 right hand cut

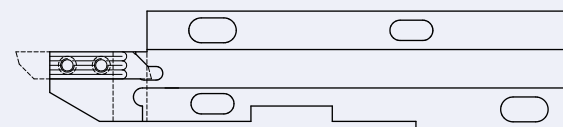

Art. N°
740-DECO10

A utiliser sur
 porte-outil TORNOS
 court à droite

Auf TORNOS rechten
 kurzen Werkzeughalter
 verwenden

To be used on
 TORNOS short tool
 holder right

TORNOS N° 305 008

utiliser des plaquettes série 740
 Wendeplatten Serie 740 verwenden
 use inserts series 740

voir page :
 siehe Seite : 1.27 - 1.41
 see page :

serrage standard (A) uniquement
 nur standard Spannsystem (A)
 standard clamping system (A) only

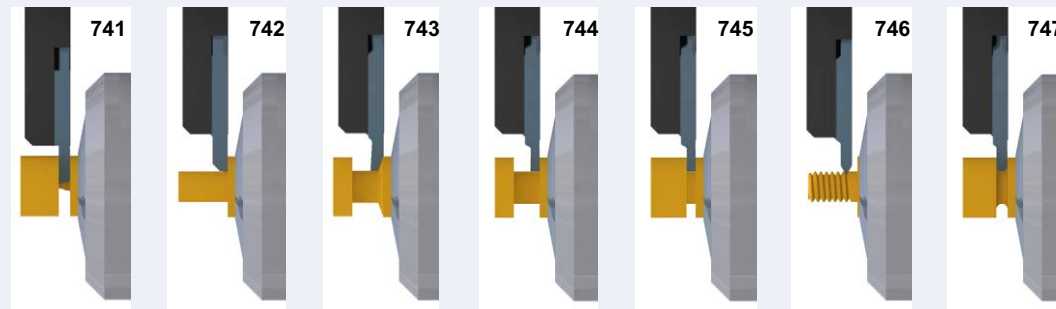

coupe à droite déportée
 versetztes Rechtsschneiden
 right cut off line

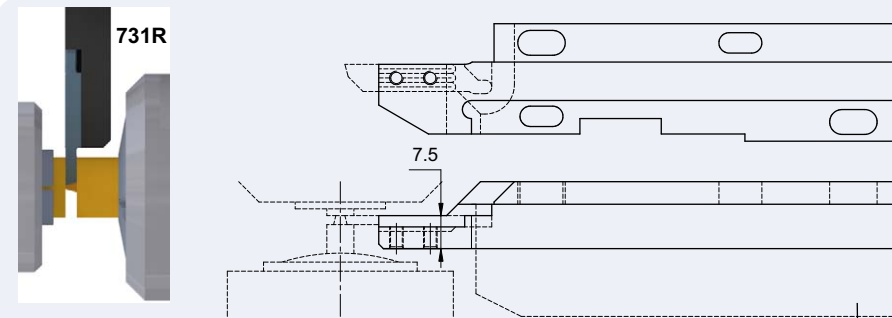

Art. N°
730R-DECO10

A utiliser sur
 porte-outil TORNOS
 court à droite

Auf TORNOS rechten
 kurzen Werkzeughalter
 verwenden

To be used on
 TORNOS short
 tool holder right

voir page :
 siehe Seite : 1.31
 see page :

TORNOS N° 305 008

L

Porte-outils spéciaux pour machine TORNOS DECO 7 / 10 mm
 Sonderhalter für TORNOS DECO 7 / 10 mm Maschine
 Special holders for TORNOS DECO 7 / 10 mm machine

Pour le tronçonnage de petites pièces
 Zum Abstechen von kleinen Werkstücken
 For small parts parting off

porte-outils
 Halter
 holders

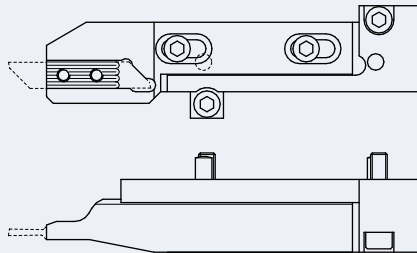

avec vis de réglage
 mit Einstellungsschraube
 with adjustment screw

Art. N°
760L-DECO10

tronçonnage
 abstechen
 parting off

761L

tronçonnage sur la ligne d'outil
 abstechen auf dem Werkzeugnullpunkt
 cut off on tool ref. line

E	L	Art. N°	TIN	TIALN	N (µK20)	HTIN	HTA	HN (µK10)
1.0	5	761LD-1.0-8°	■	■	■	□	□	□
1.0	5	761LD-1.0-15°	■	■	■	□	□	□
1.2	5	761LD-1.2-8°	■	■	■	□	□	□
1.5	8	761LD-1.5-8°	■	■	■	□	□	□
1.5	5	761LD-1.5-15°	■	■	■	□	□	□
1.6	8	761LD-1.6-8°	■	■	■	□	□	□
1.8	10	761LD-1.8-8°	■	■	■	□	□	□
2.0	10	761LD-2.0-8°	■	■	■	□	□	□
2.0	10	761LD-2.0-15°	■	■	■	□	□	□

tronçonnage à fleur de la contre-broche
 abstechen nahe der Gegenspindel
 cut off on subspindle level

1.0	5.5	761Ls-1.0	■	■	■	□	□	□
1.5	8	761Ls-1.5	■	■	■	□	□	□
2.0	11.5	761Ls-2.0	■	■	■	□	□	□
2.2	11.5	761Ls-2.2	■	■	■	□	□	□
2.5	11.5	761Ls-2.5	■	■	■	□	□	□
3.0	11.5	761Ls-3.0	■	■	■	□	□	□

■ = Disponible / Verfügbar / Available
 □ = Avec délai de livraison / Mit Lieferfrist
 Available with delivery time

R

Porte-outils spéciaux pour machine TORNOS DECO 7 / 10 mm
 Sonderhalter für TORNOS DECO 7 / 10 mm Maschine
 Special holders for TORNOS DECO 7 / 10 mm machine

Pour le tronçonnage de petites pièces
 Zum Abstechen von kleinen Werkstücken
 For small parts parting off

porte-outils
 Halter
 holders

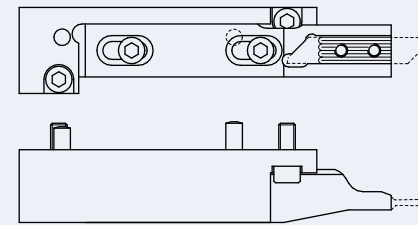

avec vis de réglage
 mit Einstellungsschraube
 with adjustment screw

Art. N°
750R-DECO10

tronçonnage
 abstechen
 parting off

751R

tronçonnage sur la ligne d'outil
 abstechen auf Werkzeugnullpunkt
 cut off on tool ref. line

E	L	Art. N°	TIN	TIALN	N (µK20)	HTIN	HTA	HN (µK10)
1.0	5	751RD-1.0-8°	■	■	■	□	□	□
1.0	5	751RD-1.0-15°	■	■	■	□	□	□
1.2	5	751RD-1.2-8°	■	■	■	□	□	□
1.5	8	751RD-1.5-8°	■	■	■	■	■	■
1.5	15	751RD-1.5-15°	■	■	■	□	□	□
1.6	8	751RD-1.6-8°	■	■	■	□	□	□
1.8	10	751RD-1.8-8°	■	■	■	□	□	□
2.0	10	751RD-2.0-8°	■	■	■	□	□	□
2.0	10	751RD-2.0-15°	■	■	■	□	□	□
2.5	10	751RD-2.5-8°	■	■	■	□	□	□

tronçonnage à fleur de la contre-broche
 abstechen nahe der Gegenspindel
 cut off on subspindle level

1.0	5.5	751Rs-1.0	■	■	■	□	□	□
1.5	8	751Rs-1.5	■	■	■	□	□	□
2.0	11.5	751Rs-2.0	■	■	■	■	■	■
2.2	11.5	751Rs-2.2	■	■	■	□	□	□
2.5	11.5	751Rs-2.5	■	■	■	□	□	□
3.0	11.5	751Rs-3.0	■	■	■	□	□	□

■ = Disponible / Verfügbar / Available
 □ = Avec délai de livraison / Mit Lieferfrist
 Available with delivery time

Porte-outils spéciaux pour machine TORNOS DECO 13 et DECO 20
 Sonderhalter für TORNOS DECO 13 und DECO 20 Maschinen
 Special holders for TORNOS DECO13 and DECO 20 machines

Outils spéciaux pour machine TORNOS Micro 8
 Werkzeuge für TORNOS Micro 8
 Tools for TORNOS Micro 8

Pour le tronçonnage de petites pièces
 Zum Abstechen von kleinen Werkstücken
 For small parts parting off

DECO 13

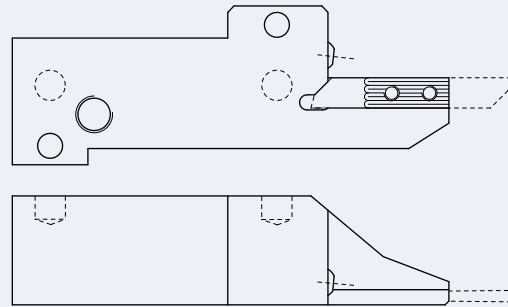

Arrosage intégré
 (raccordement externe G1/8)

Integrierte Kühlung
 (Externer Anschluss G 1/8)

Integrated cooling
 (External connection G1/8)

Art. N°
770R-DECO13

DECO 20

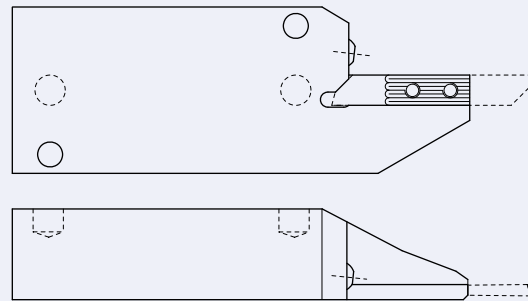

Arrosage intégré

Integrierte Kühlung

Integrated cooling

Art. N°
770R-DECO20

utiliser des plaquettes série 771R
 Wendeplatten Serie 771R verwenden
 use inserts series 771R

voir page :
 siehe Seite : 1.71
 see page :

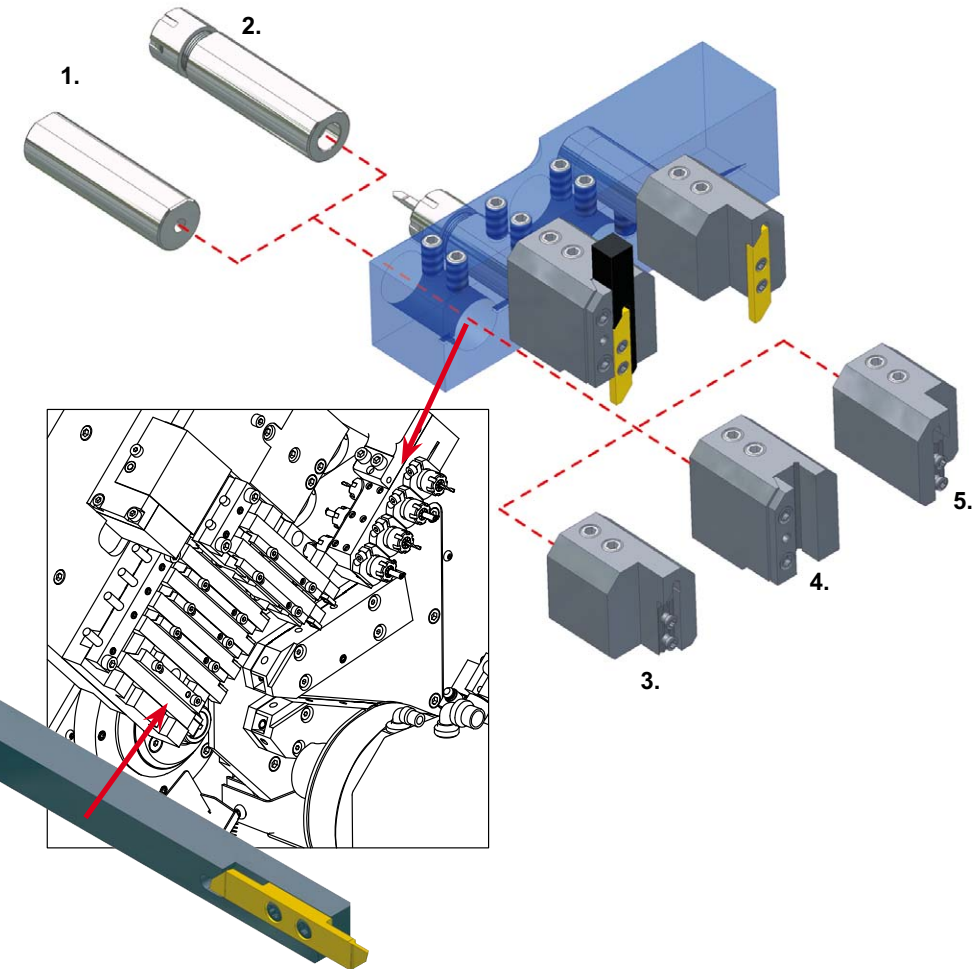

	Art. N°	
1.	D16-L55	cylindre de fixation standard cyl. Aufnahme fixturing rod
2.	D16-L50F-ER11	cylindre de fixation avec porte-pince ER11 cyl. Aufnahme mit Zangenhalter ER11 fixturing rod with ER11 collet holder
3.	S8-740	porte-outil R, plaquettes série 740 (voir pages 1.27-1.41) Halter R, WSP Serie 740 (siehe Seiten 1.27-1.41) holder R, inserts serie 740 (see pages 1.27-1.41)
4.	S8-0808	porte-outil pour outil 8 X 8 Halte für Werkzeug 8 X 8 holder for 8 X 8 square tool
5.	S8-730	porte-outil L, plaquettes série 730 (voir pages 1.26-1.40) Halte L, WSP Serie 730 (siehe Seiten 1.26-1.40) holder L, inserts serie 730 (see pages 1.26-1.40)
6.	770-12	outil de tronçonnage série 770 (voir page 1.68) Abstechwerkzeug Serie 770 (siehe Seite 1.68) parting off tool serie 770 (see page 1.68)

Outils de tournage spécifiques au domaine de l'horlogerie
 Besondere Drehwerkzeuge für die Uhrindustrie
 Special turning tools for watch industry

SF SERIES

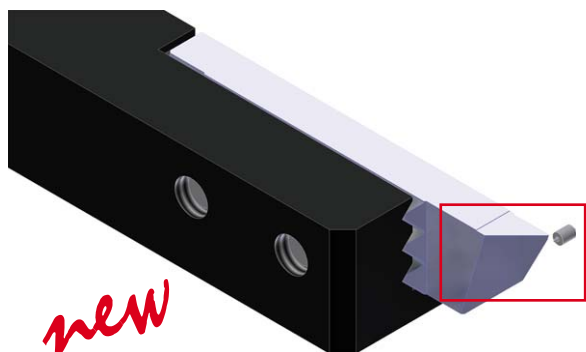

Geométries développées pour l'usinage de pièces d'horlogerie
 Nuance de carbure résistante à l'usure
 Outil dédié à l'usinage de très petites pièces
 Série 740sf adaptée aux machines CNC
 Série 710sf adaptée aux machines à came



Für die Bearbeitung von Uhrenteile entwickelte Geometrie
 Verschleissfeste Feinkornsorte
 Werkzeug für die Bearbeitung von sehr kleinen Teilen
 Serie 740sf für CNC-Maschine
 Serie 710sf für kurvengesteuerte Maschinen

Geometry developed for watch parts machining
 Wear resistant micro-grain grade
 Tool for machining of very small parts
 Series 740sf adapted for CNC machines
 Series 710sf adapted for cam driven machines

Pièce d'exemple Beispielsstück Example part

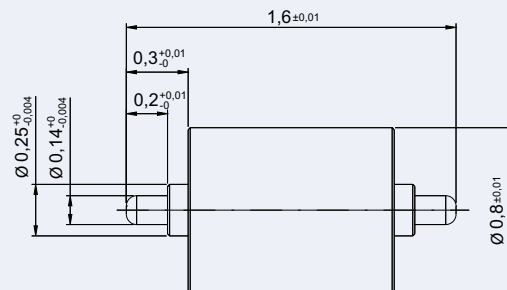

new

Outils de tournage spécifiques au domaine de l'horlogerie
 Besondere Drehwerkzeuge für die Uhrindustrie
 Special turning tools for watch industry

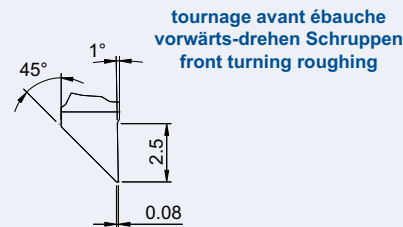

Art. N°	HTIN	HTA	HN (µK10)
742sf-8/8	<input type="checkbox"/>	<input checked="" type="checkbox"/>	<input checked="" type="checkbox"/>

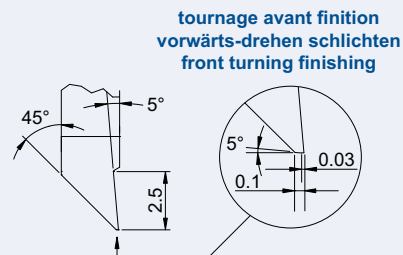

Art. N°	HTIN	HTA	HN (µK10)
742sf-10/3	<input type="checkbox"/>	<input checked="" type="checkbox"/>	<input checked="" type="checkbox"/>

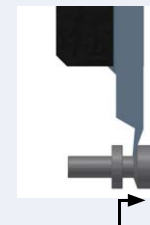
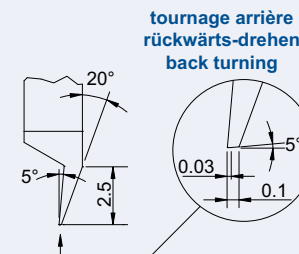

Art. N°	HTIN	HTA	HN (µK10)
743sf-10/3	<input type="checkbox"/>	<input checked="" type="checkbox"/>	<input checked="" type="checkbox"/>

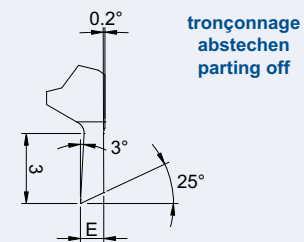

E	Art. N°	HTIN	HTA	HN (µK10)
0.8	741sf-0.8	<input type="checkbox"/>	<input checked="" type="checkbox"/>	<input checked="" type="checkbox"/>
1.0	741sf-1.0	<input type="checkbox"/>	<input checked="" type="checkbox"/>	<input checked="" type="checkbox"/>

utiliser les supports série 740 page 1.25
 Halter Serie 740 Seite 1.25 verwenden
 use holder series 740 page 1.25

■ = Disponible / Verfügbar / Available
 □ = Avec délai de livraison / Mit Lieferfrist / Available with delivery time

Outils de tournage spécifiques au domaine de l'horlogerie
 Besondere Drehwerkzeuge für die Uhrenindustrie
 Special turning tools for watch industry

new

tournage avant ébauche
 vorwärts-drehen Schruppen
 front turning roughing

Art. N°	HTIN HTA HN (μK10)
712sf-8/8	<input type="checkbox"/> <input checked="" type="checkbox"/> <input checked="" type="checkbox"/>

tournage avant finition
 vorwärts-drehen schlichten
 front turning finishing

Art. N°	HTIN HTA HN (μK10)
712sf-10/3	<input type="checkbox"/> <input checked="" type="checkbox"/> <input checked="" type="checkbox"/>

tournage arrière
 rückwärts-drehen
 back turning

Art. N°	HTIN HTA HN (μK10)
713sf-10/3	<input type="checkbox"/> <input checked="" type="checkbox"/> <input checked="" type="checkbox"/>

tronçonnage
 abstechen
 parting off

E	Art. N°	HTIN HTA HN (μK10)
0.8	711sf-0.8	<input type="checkbox"/> <input checked="" type="checkbox"/> <input checked="" type="checkbox"/>
1.0	711sf-1.0	<input type="checkbox"/> <input checked="" type="checkbox"/> <input checked="" type="checkbox"/>

utiliser les supports série 710 page 1.18
 Halter Serie 710 Seite 1.18 verwenden
 use holder series 710 page 1.18

■ = Disponible / Verfügbar / Available
 □ = Avec délai de livraison / Mit Lieferfrist / Available with delivery time

new

Porte-outils en métal lourd anti-vibratoire
 Schwingungdämpfender Schwermetallhalter
 Low vibration heavy metal holders



L 710-NOVIBRA

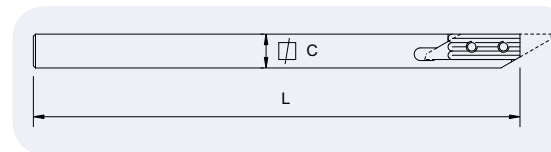

C	L	Art. N°
6 X 6	115	710-6-NOVIBRA
7 X 7	115	710-7-NOVIBRA
8 X 8	115	710-8-NOVIBRA

L 730-NOVIBRA

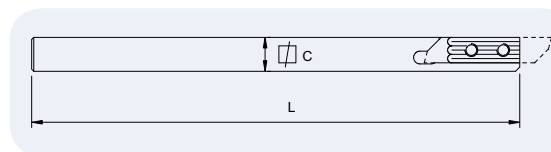

C	L	Art. N°
7 X 7	115	730-7-NOVIBRA
8 X 8	115	730-8-NOVIBRA

740-NOVIBRA R

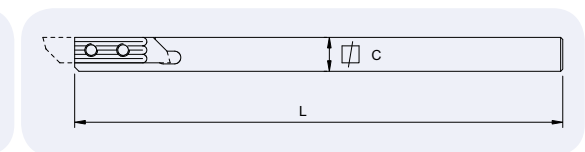

C	L	Art. N°
7 X 7	115	740-7-NOVIBRA
8 X 8	115	740-8-NOVIBRA

Porte-outils spéciaux pour usinage déporté
Sonderhalter für versetzte Bearbeitung
Special holders for shifted machining

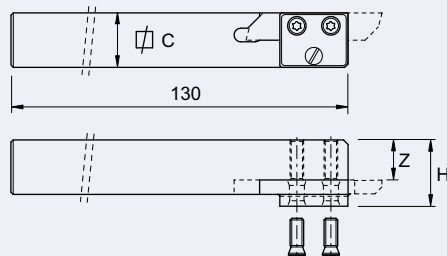

C	Z	H	Art. N°
12 X 12	9.5	14.5	740z-12
16 X 16	13.5	18.5	740z-16

utiliser des plaquettes série 740
Wendeplatten Serie 740 verwenden
use inserts series 740

voir page :
siehe Seite : 1.27 - 1.41
see page :

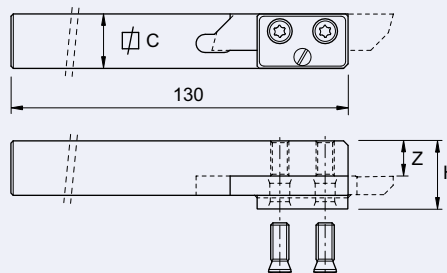





C	Z	H	Art. N°
12 X 12	8	15	760z-12
16 X 16	12	19	760z-16

utiliser des plaquettes série 760
Wendeplatten Serie 760 verwenden
use inserts series 760

voir page :
siehe Seite : 1.47 - 1.67
see page :

Vis et clés de rechange
Ersatzschrauben und Schlüssel
Spare screws and keys

	porte-outils Halter holders	serrage standard (A) standard Spannsystem (A) standard clamping system (A)		serrage type B Spannsystem Typ B clamping system type B		
						
300	311	V-M2.5x6.5-T8	C-T8	-	-	
	312 >>> 316	V-M2.5x7.8-T8	C-T8	-	-	
	322 >>> 326	V-M2.5x7.8-T8	C-T8	-	-	
	332 >>> 336	V-M2.5x7.8-T8	C-T8	-	-	
	342 >>> 346	V-M2.5x7.8-T8	C-T8	-	-	
710	710-6	V-M2.5x5.8-T8	C-T8	-	-	
	710-7	V-M2.5x6.5-T8	C-T8	-	-	
	710-8 >>> 710-12	V-M2.5x7.8-T8	C-T8	-	-	
	720	720-7	V-M2.5x6.5-T8	C-T8	-	-
	720-8 >>> 720-12	V-M2.5x7.8-T8	C-T8	-	-	
730	730-7	V-M3x7-T8	C-T8	-	-	
	730-8 >>> 730-16	V-M3x7-T8	C-T8	V-M2.5x7.8-T8	C-T8	
	730-DECO10	V-M3x7-T8	C-T8	-	-	
	730R-DECO10	V-M3x7-T8	C-T8	-	-	
	730RC	V-M3x5.5-T8	C-T8	-	-	
740	740-7 >>> 740-16	V-M3x7-T8	C-T8	V-M2.5x7.8-T8	C-T8	
	740/730-D	V-M3x7-T8	C-T8	-	-	
	740-C	V-M3x5.5-T8	C-T8	-	-	
	740-DECO10	V-M3x7-T8	C-T8	-	-	
	740L-DECO10	V-M3x7-T8	C-T8	-	-	
	740-Z	V-M3x9-T8	C-T8	-	-	
	750	750-10	V-M4x9-T15	C-T15	-	-
	750-10-AB	V-M4x9-T15	C-T15	V-M3x10-BN21	C-6P-2.0	
	750-12	V-M4x9-T15	C-T15	-	-	
	750-12-AB	V-M4x9-T15	C-T15	V-M3x8-BN11	C-6P-2.5	
	750-13	V-M4x9-T15	C-T15	V-M3x10-BN11	C-6P-2.5	
	750-14	V-M4x9-T15	C-T15	V-M3x10-BN11	C-6P-2.5	
	750-16	V-M4x9-T15	C-T15	V-M3x12-BN11	C-6P-2.5	
	750-20	V-M4x9-T15	C-T15	V-M3x16-BN11	C-6P-2.5	
	750RAS	V-M4x7.3-T15	C-T15	-	-	
	750RC	V-M4x7.3-T15	C-T15	-	-	
	750R-DECO10	V-M4x5.6-T15	C-T15	-	-	
760	760-10	V-M4x9-T15	C-T15	-	-	
	760-10-AB	V-M4x9-T15	C-T15	V-M3x10-BN21	C-6P-2.0	
	760-12	V-M4x9-T15	C-T15	-	-	
	760-12-AB	V-M4x9-T15	C-T15	V-M3x8-BN11	C-6P-2.5	
	760-13	V-M4x9-T15	C-T15	V-M3x10-BN11	C-6P-2.5	
	760-14	V-M4x9-T15	C-T15	V-M3x10-BN11	C-6P-2.5	
	760-16	V-M4x9-T15	C-T15	V-M3x12-BN11	C-6P-2.5	
	760-20	V-M4x9-T15	C-T15	V-M3x16-BN11	C-6P-2.5	
	760/750-25	V-M4x9-T15	C-T15	-	-	
	760/750-D	V-M4x9-T15	C-T15	-	-	
	760LC	V-M4x7.3-T15	C-T15	-	-	
	760L-DECO10	V-M4x5.6-T15	C-T15	-	-	
	760-Z	V-M4x12-T15	C-T15	-	-	
	770	770-12 >>> 770-25	V-M4x9-T15	C-T15	-	-
		770R-DEC013	V-M4x7.3-T15	C-T15	-	-
	770R-DEC020	V-M4x7.3-T15	C-T15	-	-	
780	780-12 >>> 780-25	V-M4x9-T15	C-T15	-	-	
7050	7050-16 >>> 7050-25	V-M4x9-T15	C-T15	-	-	
7060	7060-16 >>> 7060-25	V-M4x9-T15	C-T15	-	-	
W	W750	V-M4x11-T15	C-T15	-	-	
	W760	V-M4x11-T15	C-T15	-	-	

serrage
standard (A)

standard
Spannsystem (A)

standard
clamping system (A)

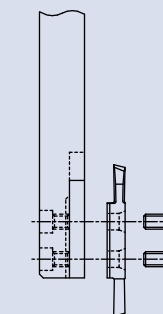

serrage
type B

Spannsystem
Typ B

clamping system
type B

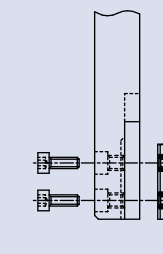



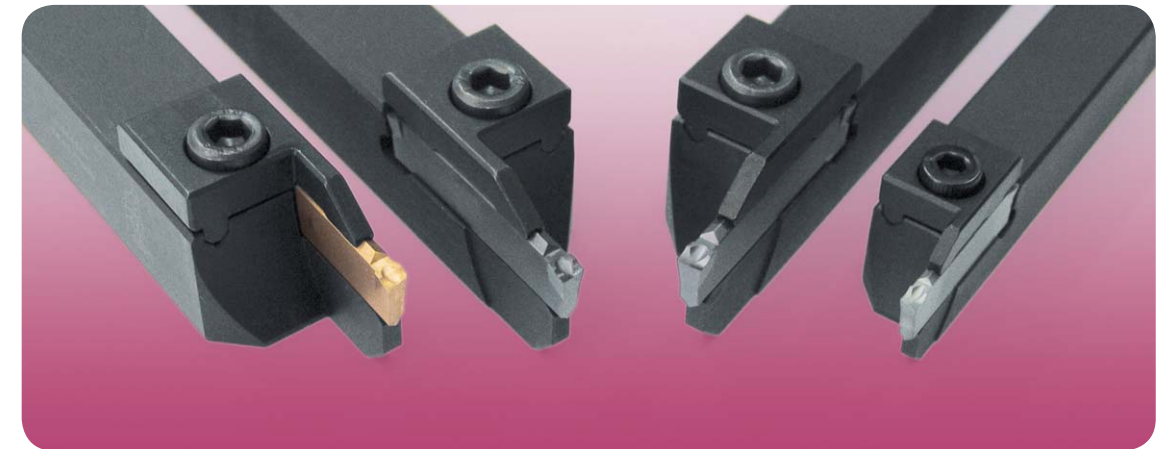
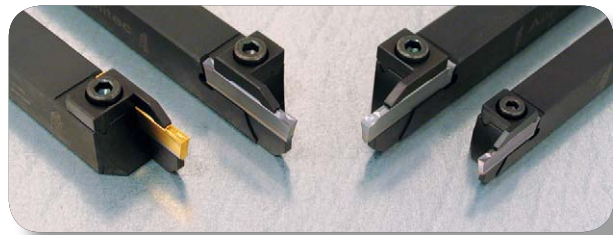

CUT-LINE

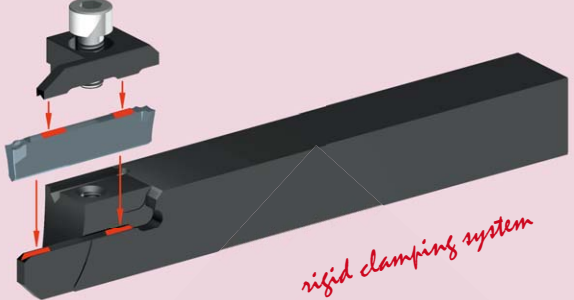

Répertoire Verzeichnis Index	Type	page Seite page
------------------------------------	------	-----------------------

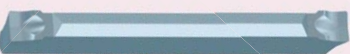
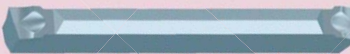
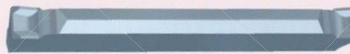
Paramètres et nuances Schnittwerte und Sorten Data and grades	INFO & DATA	2.02-2.03
---	-------------	-----------

	Ø max 34 mm	H	2.04
	Ø max 42 mm	HX	2.05
		UN	2.06
		UL UR	2.07
<i>new</i> 		TN	2.08
		GN	2.09

Nuances des plaquettes
Wendeplatte-Sorten
PVD thin coating

TiAlN revêtement PVD PVD Beschichtung PVD coating	<i>new</i> HTA revêtement PVD PVD Beschichtung PVD coating	Tmax revêtement PVD PVD Beschichtung PVD coating
nuance universelle bonne résistance aux chocs pour l'usinage des aciers, aciers inoxydables et alliages de titane en conditions défavorables	excellente nuance universelle très bonne résistance à l'usure 1er choix pour le tronçonnage des aciers, aciers inoxydables et alliages de titane	nuance pour usinage moyen à lourd des aciers, aciers alliés et inoxydables bonne résistance aux températures d'usinage élevées 1er choix pour le tronçonnage des aciers au carbone et des aciers fortement alliés
Universalsorte gute Bruchfestigkeit für die Bearbeitung von Stahl, rostfreiem Stahl und Titanlegierungen in schwierige Bearbeitungsfälle	beste Universalsorte sehr gute Verschleissfestigkeit für die Bearbeitung von Stahl, rostfreiem Stahl und Titanlegierung bestens geeignet	Sorte für mittlere bis hohe Belastung in Stahl und legierter Stahlbearbeitung gute Bearbeitungswarmfestigkeit bestens geeignet für die Bearbeitung von legiertem Kohlenstahl und hoch legiertem Stahl
universal grade good impact resistance for machining of steel, stainless steel and titanium alloys in unfavourable machining conditions	best universal grade very good wear resistance first choice for steel, stainless steel and titanium alloys machining	grade for medium to heavy machining of steel, stainless steel and alloyed steel high machining heat resistance first choice for the machining of carbon steel and high alloyed steel

<i>new</i> HTX revêtement PVD PVD Beschichtung PVD coating	AS revêtement PVD PVD Beschichtung PVD coating
nuance complémentaire hautement résistante à l'usure pour l'usinage des aciers à forte abrasion pour le tronçonnage avec faible avance des aciers au carbone, fortement alliés et inoxydables fortement déconseillé en coupe interrompue	nuance pour métaux non ferreux très faible coefficient de frottement 1er choix pour l'usinage des aluminiums jusqu'à 10 % Si, des cuivres et titanes faiblement alliés
Zusätzliche Sorte mit hoher Verschleissfestigkeit in Stahlbearbeitung für die Bearbeitung bei niedrigen Vorschüben von legiertem Kohlenstahl und hoch legiertem Stahl bestens geeignet in unterbrochenen Schnitte nicht geeignet	Sorte für Nichteisenmetalle sehr geringer Reibwert für die Bearbeitung von Aluminium bis 10% Si, Kupfer und niedriglegiertem Titan bestens geeignet
complementary grade highly wear resistant for machining for steel with high abrasion for machining with low cutting feed for carbon steel, high alloyed steel and stainless steel not suitable for interrupted cut	grade for non-ferrous materials very low friction ratio first choice for Aluminium up to 10 % Si, Copper and low alloyed Titanium

Paramètres de coupe indicatifs
Empfohlene Schnittwerte
Standard machining data

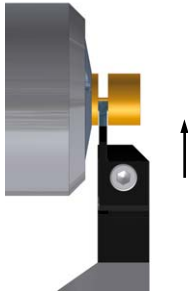
Tronçonnage Abstechen Cut off	Matière Werkstoff Material	Vc (m/min)	Géométries de coupe Spanformgeometrien cutting geometries	
			Type U F (mm/U)	Type T F (mm/U)
	Acier de décolletage Automatenstahl Free-cutting steel	80 - 150	0.02 - 0.10	0.10 - 0.20
	Acier Stahl Steel < 600 N/mm2	70 - 120	0.02 - 0.08	0.10 - 0.20
	Acier Stahl Steel < 800 N/mm2	60 - 100	0.02 - 0.06	0.10 - 0.18
	Acier Stahl Steel > 800 N/mm2	40 - 80	0.02 - 0.05	0.08 - 0.15
	Acier inoxydable Rostfreistahl Stainless steel	60 - 100	0.02 - 0.10	0.08 - 0.20
	Aluminium	150 - 300	0.02 - 0.15	-
	Titane Titan Titanium	30 - 60	0.02 - 0.08	-
	Cuivre, laiton, bronze Kupfer, Messing, Bronze Copper, brass, bronze	100 - 300	0.02 - 0.10	0.08 - 0.20

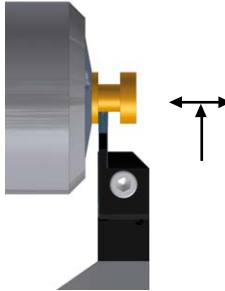
Tournage Drehen Turning	Matière Werkstoff Material	Vc (m/min)	Type G	
			CUT22 F (mm/U)	CUT31 F (mm/U)
	Acier de décolletage Automatenstahl Free-cutting steel	100 - 200	0.03 - 0.12	0.04 - 0.15
	Acier Stahl Steel < 600 N/mm2	80 - 160	0.03 - 0.10	0.04 - 0.12
	Acier Stahl Steel < 800 N/mm2	60 - 120	0.03 - 0.08	0.04 - 0.10
	Acier Stahl Steel > 800 N/mm2	50 - 100	0.03 - 0.07	0.04 - 0.08
	Acier inoxydable Rostfreistahl Stainless steel	60 - 120	0.03 - 0.08	0.04 - 0.10
	Aluminium	180 - 400	0.03 - 0.12	0.04 - 0.15
	Titane Titan Titanium	40 - 70	0.03 - 0.08	0.04 - 0.10
	Cuivre, laiton, bronze Kupfer, Messing, Bronze Copper, brass, bronze	100 - 400	0.03 - 0.10	0.04 - 0.12

Ø max 34 mm

Porte-outils
Halter
Holders

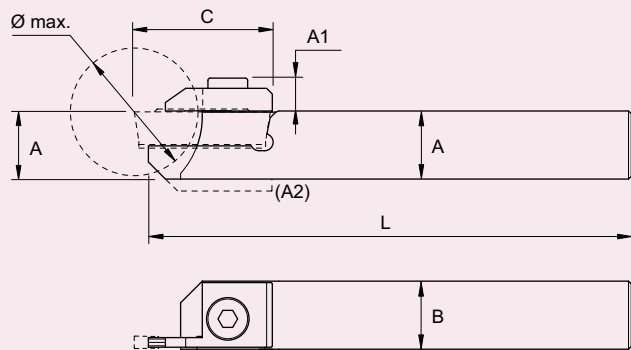

L

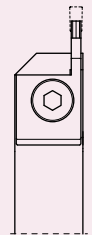

R

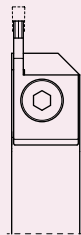

Plaquette WSP Insert	A x B x L	Ø max.	A1	C	Art. N°	Art. N°
W 1.6 mm Type CUT16	8 x 10 x 115 (A2=2)	16	6.2	19.5	CUT16-H0810L	CUT16-H0810R
	10 x 10 x 115	16	6.2	19.5	CUT16-H1010L	CUT16-H1010R
	12 x 12 x 130	16	6.2	19.5	CUT16-H1212L	CUT16-H1212R
	12 x 12 x 90	16	6.2	19.5	CUT16-H1212L-90	CUT16-H1212R-90
	13 x 13 x 130	16	6.2	19.5	CUT16-H1313L	CUT16-H1313R
	16 x 16 x 130	16	6.2	19.5	CUT16-H1616L	CUT16-H1616R
	20 x 20 x 120	16	6.2	19.5	CUT16-H2020L	CUT16-H2020R
W 2.2 mm Type CUT22	10 x 12 x 115	20	6.4	24	CUT22-H1012L	CUT22-H1012R
	12 x 12 x 130	20	6.4	24	CUT22-H1212L	CUT22-H1212R
	12 x 12 x 90	20	6.4	24	CUT22-H1212L-90	CUT22-H1212R-90
	13 x 13 x 130	20	6.4	24	CUT22-H1313L	CUT22-H1313R
	16 x 16 x 130	20	6.4	24	CUT22-H1616L	CUT22-H1616R
	20 x 20 x 120	20	6.4	24	CUT22-H2020L	CUT22-H2020R
W 3.1 mm Type CUT31	16 x 16 x 130	34	7.8	35	CUT31-H1616L	CUT31-H1616R
	20 x 20 x 120	34	7.8	35	CUT31-H2020L	CUT31-H2020R
	25 x 25 x 140	34	7.8	35	CUT31-H2525L	CUT31-H2525R

Pièces de rechange
Ersatzteile
Spare parts

L

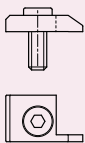

Art. N°
CUT16L-SET
CUT22L-SET
CUT31L-SET

R

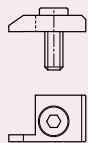

Art. N°
CUT16R-SET
CUT22R-SET
CUT31R-SET

Ø max 42 mm

Porte-outils
Halter
Holders

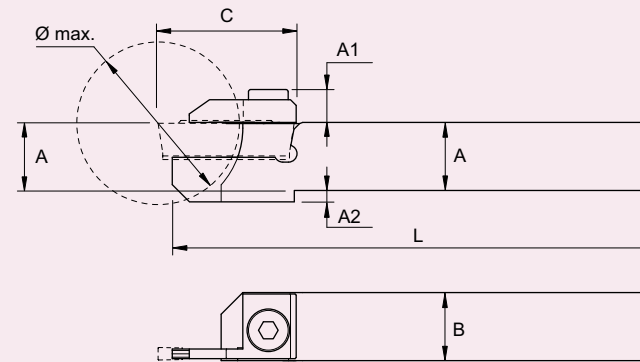

L

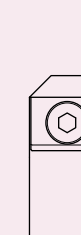

R

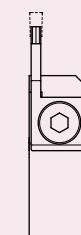

Plaquette WSP Insert	A x B x L	Ø max.	A1	C	A2	Art. N°	Art. N°
W 1.6 mm Type CUT16	10 x 12 x 115	20	6.2	21	2	CUT16-H1012LX	CUT16-H1012RX
	12 x 12 x 130	20	6.2	21	-	CUT16-H1212LX	CUT16-H1212RX
	12 x 12 x 90	20	6.2	21	-	CUT16-H1212LX-90	CUT16-H1212RX-90
	13 x 13 x 130	20	6.2	21	-	CUT16-H1313LX	CUT16-H1313RX
	16 x 16 x 130	20	6.2	21	-	CUT16-H1616LX	CUT16-H1616RX
	20 x 20 x 120	20	6.2	21	-	CUT16-H2020LX	CUT16-H2020RX
	W 2.2 mm Type CUT22	10 x 12 x 115	26	6.4	25	4	CUT22-H1012LX
12 x 12 x 130		26	6.4	25	2	CUT22-H1212LX	CUT22-H1212RX
12 x 12 x 90		26	6.4	25	2	CUT22-H1212LX-90	CUT22-H1212RX-90
13 x 13 x 130		26	6.4	25	-	CUT22-H1313LX	CUT22-H1313RX
16 x 16 x 130		26	6.4	25	-	CUT22-H1616LX	CUT22-H1616RX
20 x 20 x 120		26	6.4	25	-	CUT22-H2020LX	CUT22-H2020RX
W 3.1 mm Type CUT31	16 x 16 x 120	42	7.8	37	4	CUT31-H1616LX	CUT31-H1616RX
	20 x 20 x 120	42	7.8	37	-	CUT31-H2020LX	CUT31-H2020RX
	25 x 25 x 140	42	7.8	37	-	CUT31-H2525LX	CUT31-H2525RX

Pièces de rechange
Ersatzteile
Spare parts

L

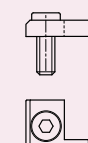

Art. N°
CUT16LX-SET
CUT22LX-SET
CUT31LX-SET

R

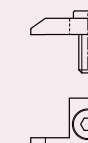

Art. N°
CUT16RX-SET
CUT22RX-SET
CUT31RX-SET

Plaquettes en métal dur pour tronçonnage
VHM-Abstechwendeplatten
Solid carbide cut off inserts

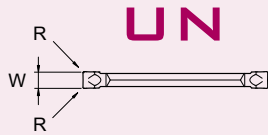
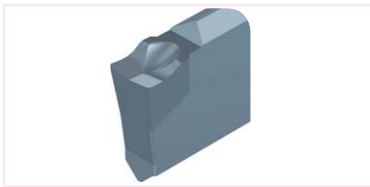
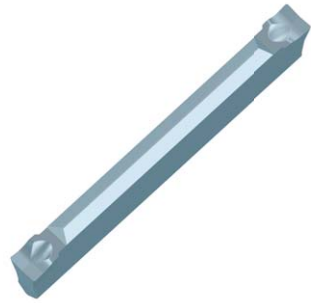
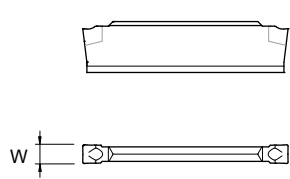

Type	W +/-0.05	A	R	Art. N°	HTA	HTX	TIALN	Tmax	AS
CUT16	1.6	-	0.02	CUT16-UN-000	■	■	■	■	
	1.6	-	0.10	CUT16-UN-001	■	■	■	■	
CUT22	2.2	-	0.02	CUT22-UN-000	■	■	■	■	
	2.2	-	0.20	CUT22-UN-002	■	■	■	■	
CUT31	3.1	-	0.02	CUT31-UN-000	■	■	■	■	
	3.1	-	0.20	CUT31-UN-002	■	■	■	■	

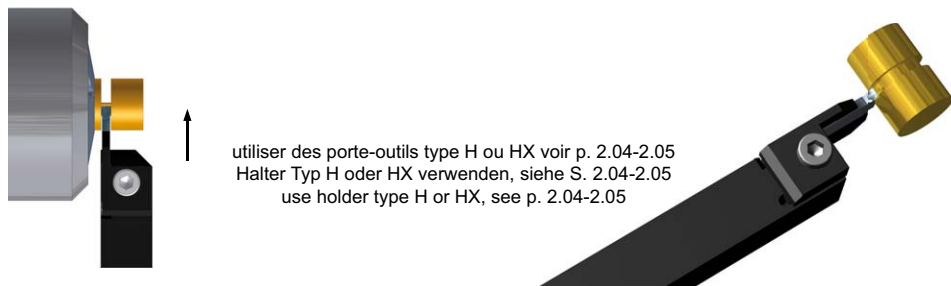

utiliser des porte-outils type H ou HX voir p. 2.04-2.05
Halter Typ H oder HX verwenden, siehe S. 2.04-2.05
use holder type H or HX, see p. 2.04-2.05

■ = Disponible / Verfügbar / Available

Plaquettes en métal dur pour tronçonnage
VHM-Abstechwendeplatten
Solid carbide cut off inserts

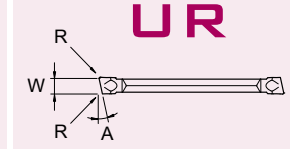
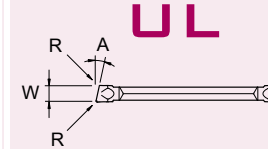
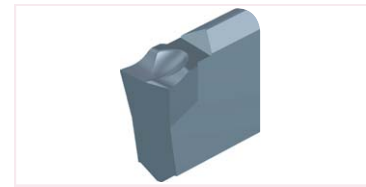
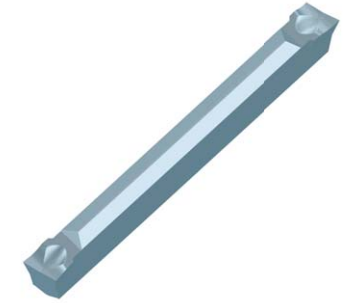
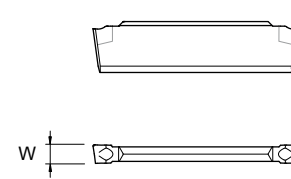

Type	W +/-0.05	A	R	Art. N°	Art. N°	HTA	HTX	TIALN	Tmax	AS
CUT16	1.6	8°	0.02	CUT16-UL-800	CUT16-UR-800	■	■	■	■	
	1.6	15°	0.02	CUT16-UL-1500	CUT16-UR-1500	■	■	■	■	
CUT22	2.2	8°	0.02	CUT22-UL-800	CUT22-UR-800	■	■	■	■	
	2.2	8°	0.20	CUT22-UL-802	CUT22-UR-802	■	■	■	■	
	2.2	15°	0.02	CUT22-UL-1500	CUT22-UR-1500	■	■	■	■	
CUT31	3.1	8°	0.02	CUT31-UL-800	CUT31-UR-800	■	■	■	■	
	3.1	8°	0.20	CUT31-UL-802	CUT31-UR-802	■	■	■	■	
	3.1	15°	0.02	CUT31-UL-1500	CUT31-UR-1500	■	■	■	■	

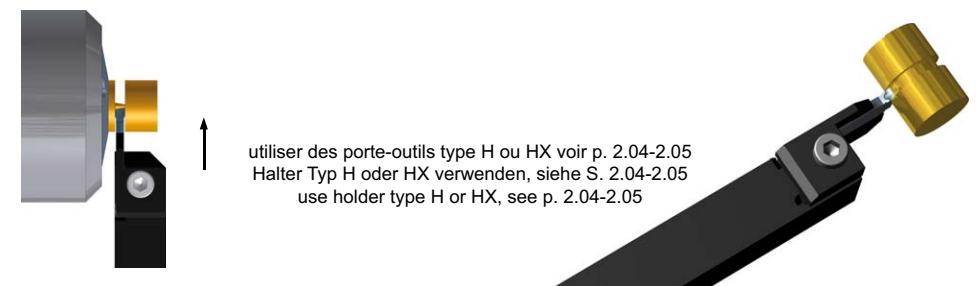

utiliser des porte-outils type H ou HX voir p. 2.04-2.05
Halter Typ H oder HX verwenden, siehe S. 2.04-2.05
use holder type H or HX, see p. 2.04-2.05

■ = Disponible / Verfügbar / Available

T CUT-LINE

Plaquettes en métal dur pour tronçonnage Ø 12-42mm
 VHM-Abstechwendeplatten Ø 12-42mm
 Solid carbide cut off inserts Ø 12-42mm



new

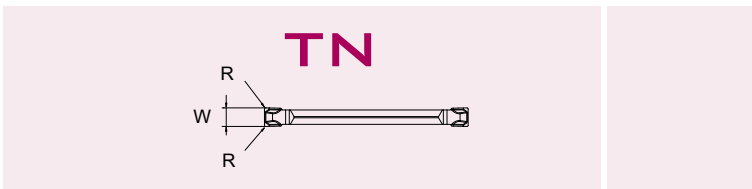

Type	W +/-0.05	A	R	Art. N°	TIALN Tmax
CUT 22	2.2	-	0.20	CUT22-TN-002	■ ■
CUT31	3.1	-	0.20	CUT31-TN-002	■ ■

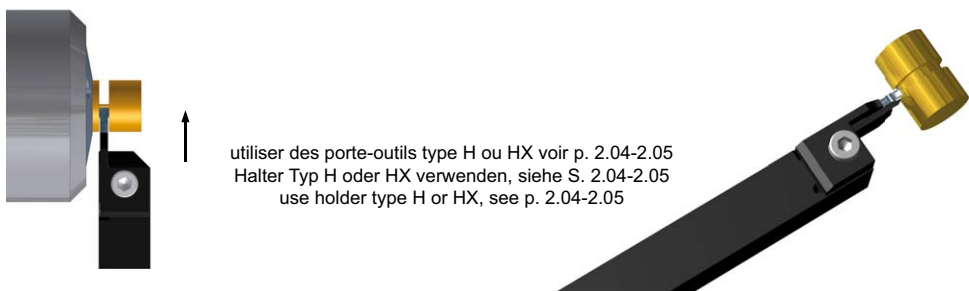

Caractéristiques des plaquettes type TN Eigenschaften der TN-Wendeplatten Characteristic of TN inserts



Negative cut off

Ø 12-42mm

Pour avance moyenne à élevée
 Für mittlere bis hohe Vorschübe
 Medium high feed

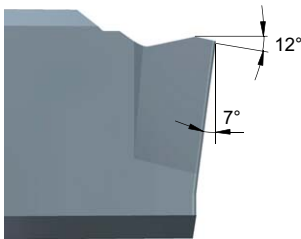

■ = Disponible / Verfügbar / Available

G CUT-LINE

Plaquettes en métal dur pour fonder tourner
 VHM-Wendeplatten zum einstecken und drehen
 Solid carbide inserts for grooving and turning

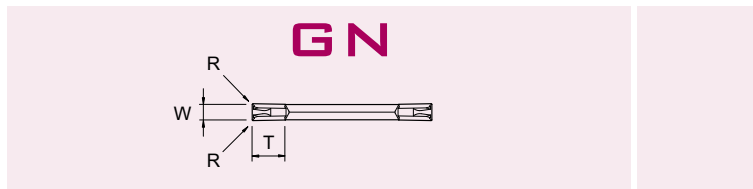
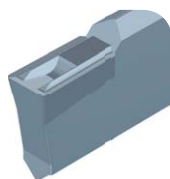

Type	W +/-0.05	T	R	Art. N°	TIALN Tmax AS
CUT22	2.2	3.5	0.15	CUT22-GN-002	■ ■ ■
CUT31	3.1	5	0.15	CUT31-GN-002	■ ■ ■

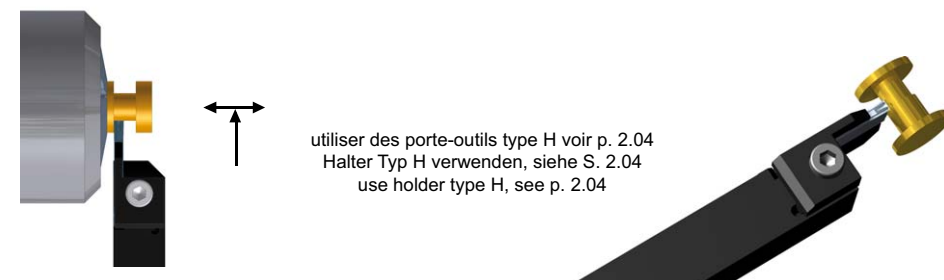

Conseils d'utilisation pour plaquettes type GN Anwendungsempfehlungen für GN-Wendeplatten Application recommendations for GN inserts

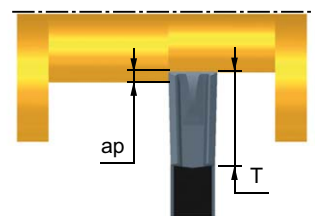
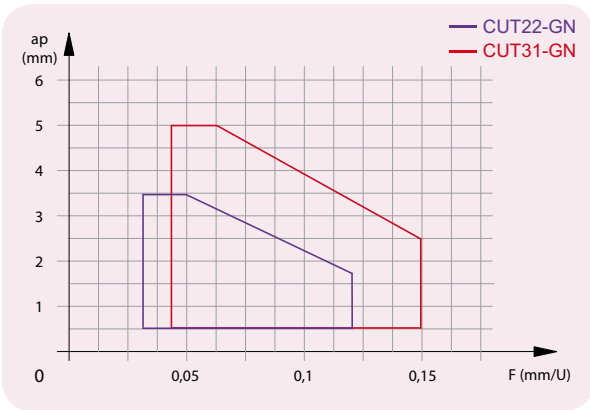

ap max=T dans matière à bonne usinabilité
 ap max=T in Werkstoffe mit gute Zerspanbarkeit
 ap max=T in material with good machinability











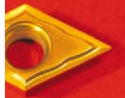
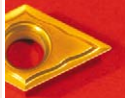



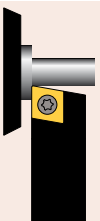
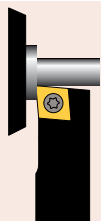
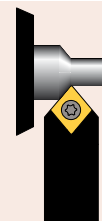
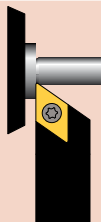

Matière / Vc (m/min) - F (mm/U)
 Werkstoff / Vc (m/min) - F (mm/U)
 Material / Vc (m/min) - F (mm/U)

voir page :
 siehe Seite : **2.03**
 see page :

■ = Disponible / Verfügbar / Available

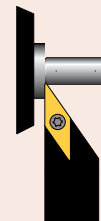
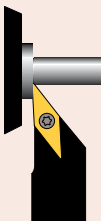
ISO-LINE

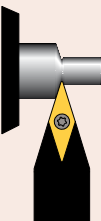

Paramètres et nuances Schnittwerte und Sorten Data and grades	INFO & DATA				3.02 3.03	
Géométries des plaquettes WSP-Spanform- Geometrien Inserts cutting geometries		FN-X8°	3.04		ENP-X8° 3.04	
		FN-X17°	3.05		ENP-X17° 3.05	
		FN-X25°	3.06		ENP-X25° 3.06	
		FL/R-X10° FN-K18° FN-0°	3.07 3.08		EN-XF 3.08	
		EN-MF	3.09		EN-HF 3.09	
Porte-outils et plaquettes Halter und WSP Holders and inserts 80°				3.10 - 3.13		
Porte-outils et plaquettes Halter und WSP Holders and inserts 55°					3.14 - 3.19	
Porte-outils et plaquettes Halter und WSP Holders and inserts 35°						3.20 - 3.25

Nuances des plaquettes Wendepatte-Sorten Insert grades

TiN revêtement PVD PVD Beschichtung PVD coating	TiAlN revêtement PVD PVD Beschichtung PVD coating	HTA revêtement PVD PVD Beschichtung PVD coating
nuance universelle pour travaux légers très faible coefficient de frottement 1er choix pour l'usinage des matières peu résistantes qui créent des arêtes rapportées à éviter pour l'usinage du titane	nuance universelle bonne résistance à la température 1er choix pour l'usinage finition des aciers, aciers inoxydables et alliages de titane	nuance très résistante à l'usure très bonne résistance à la température déconseillé en cas de coupe interrompue et autres conditions d'usinage défavorables
Universal-Sorte für leichte Bearbeitung sehr geringer Reibwert für die Bearbeitung von weichen Werkstoffen mit Tendenz zur Bildung von Aufbauschneiden bestens geeignet für die Bearbeitung von Titan nicht geeignet	Universal-Sorte sehr gute Warmfestigkeit für die Bearbeitung von Stahl, rostfreiem Stahl und Titanlegierungen bestens geeignet	sehr verschleissfeste Sorte sehr gute Warmfestigkeit für unterbrochene Schnitte und andere ungünstige Bearbeitungsbedingungen nicht geeignet
universal grade for light machining very low friction ratio first choice for low resistance materials which causes edge build-up not suitable for titanium machining	universal grade good heat resistance first choice for steel, stainless steel and titanium alloys machining	very wear resistant grade very good heat resistance not suitable for interrupted cut and other unfavourable machining conditions

Tmax revêtement PVD PVD Beschichtung PVD coating	Ti3 revêtement CVD CVD Beschichtung CVD coating	K10 non revêtu unbeschichtet uncoated	K20 non revêtu unbeschichtet uncoated
nuance pour usinage moyen à lourd des aciers, aciers alliés et inoxydables très faible coefficient de frottement résiste aux températures d'usinage élevées	nuance tenace très polyvalente pour usinage moyen à lourd des aciers et aciers inoxydables résiste aux températures d'usinage élevées	nuance micro-grain très résistante à l'usure recommandé pour l'usinage du titane déconseillé en cas de coupe interrompue	nuance micro-grain tenace 1er choix comme base pour un revêtement supporte les coupes interrompues
Sorte für mittlere bis hohe Belastung in Stahl, Stahllegierung und rostfreier Stahlbearbeitung sehr geringer Reibwert hohe Bearbeitungswarmfestigkeit	Zähe und vielseitige Sorte für mittlere bis hohe Belastung in Stahl und rostfreiem Stahlbearbeitung hohe Bearbeitungswarmfestigkeit	verschleissfeste Feinkorn-Sorte empfehlenswert für Titanbearbeitung für unterbrochene Schnitte nicht geeignet	zähe Feinkornsorte beste Basis für eine Beschichtung für unterbrochene Schnitte geeignet
grade for medium to heavy machining of steel, alloys steel and stainless steel very low friction ratio high machining heat resistance	strong and very versatile grade for medium to heavy machining of steel and stainless steel high machining heat resistance	wear resistant micro-grain grade suitable for titanium machining not suitable for interrupted cut	tough micro-grain grade first choice as base for coating suitable for interrupted cut

Paramètres de coupe indicatifs Empfohlene Schnittwerte Standard machining data

Vc m / min	Nuances			Sorten		Grades	
	PVD			CVD		non revêtu unbeschichtet uncoated	
Matière Werkstoff Material	TiN	TiAlN HTA	Tmax	Ti3	K10	K20	
Acier de décolletage Automatenstahl Free-cutting steel	120 - 180	120 - 200	120 - 220	120 - 250			
Acier Stahl Steel < 600 N/mm²	80 - 150	80 - 170	80 - 200	100 - 220			
Acier Stahl Steel < 800 N/mm²	60 - 120	60 - 150	60 - 180	100 - 200			
Acier Stahl Steel > 800 N/mm²		50 - 120	60 - 150	80 - 180			
Acier inoxydable Rostfreier Stahl Stainless steel	80 - 120	60 - 140	80 - 160	100 - 200			
Aluminium Si < 12%	250 - 2000				250 - 2000	250 - 1500	
Aluminium Si > 12%	200 - 1500				200 - 1500	200 - 1000	
Titane Titan Titanium		30 - 80			30 - 70	30 - 60	
Cuivre, laiton, bronze Kupfer, Messing, Bronze Copper, brass, bronze	100 - 500				100 - 500	100 - 300	

Conseils d'utilisation Anwendungsempfehlungen Application recommendations

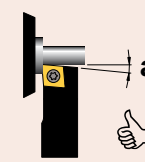

pour un meilleur état de surface et une meilleure stabilité d'usinage, choisir une géométrie d'outil permettant un angle "a" le plus petit possible

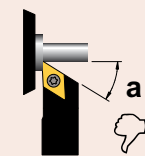

für bessere Oberflächegüte und Bearbeitungsstabilität, muss die Werkzeuggeometrie mit kleinstmöglichem Winkel "a" ausgewählt werden.

for a better surface finish and better machining stability, choose a tool geometry with angle "a" as small as possible

Rapport hauteur de passe / rayon d'outil Verhältnis zwischen Spantiefe und Werkzeugradius machining depth / tool radius ratio

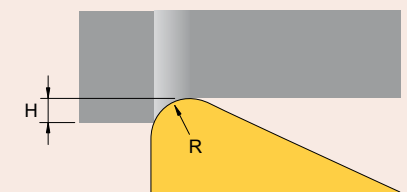

$$H \min = 0.7 \times R$$

$$R \max = 1.4 \times H$$

Géométries de coupe
Spanformgeometrien
cutting geometries

type
FN-X8°

arête de coupe vive
scharfe Schneidkante
sharp cutting edge

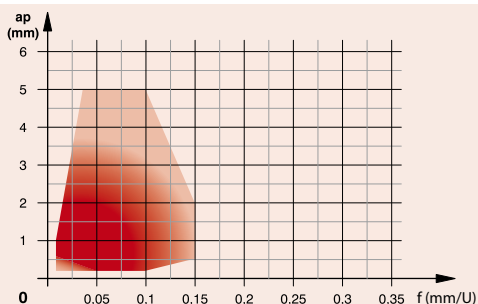
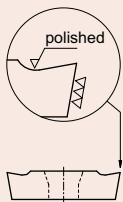

Matière
Werkstoff
Material

voir page :
siehe Seite :
see page :
3.03

Descriptif

- plaquette polie et rectifiée
- arête de coupe vive
- coupe positive 8° avec maîtrise des copeaux
- nuances micro-grain avec revêtements PVD

Beschreibung

- polierte und geschliffene Wendeplatte
- scharfe Schneidkante
- 8° positiver Schnitt mit kontrolliertem Spanbruch
- Feinkornsorten mit PVD-Beschichtungen

Description

- polished and ground insert
- sharp cutting edge
- 8° positive cut with controlled chip-breaking
- micrograin grades with PVD coatings

Application

- finition
- géométrie universelle pour l'usinage de toutes matières
- avance F = 0.01-0.15 mm / U

Anwendung

- Schlichtbearbeitung
- allgemeine Geometrie für die Bearbeitung aller Werkstoffe
- Vorschub F = 0.01-0.15 mm / U

Application

- finishing
- general purpose geometry for the machining of all materials
- feed rate F = 0.01-0.15 mm / U

Géométries de coupe
Spanformgeometrien
cutting geometries

type
FN-X17°

arête de coupe vive
scharfe Schneidkante
sharp cutting edge

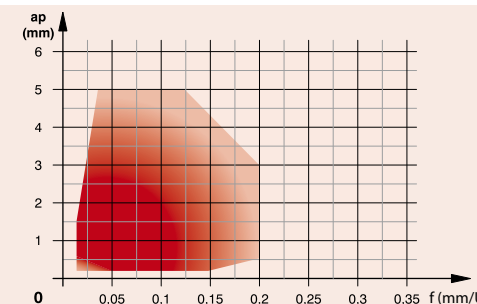

Matière
Werkstoff
Material

voir page :
siehe Seite :
see page :
3.03

Descriptif

- plaquette polie et rectifiée
- arête de coupe vive
- coupe positive 17° avec maîtrise des copeaux
- nuances micro-grain avec revêtements PVD

Beschreibung

- polierte und geschliffene Wendeplatte
- scharfe Schneidkante
- 17° positiver Schnitt mit kontrolliertem Spanbruch
- Feinkornsorten mit PVD-Beschichtungen

Description

- polished and ground insert
- sharp cutting edge
- 17° positive cut with controlled chip-breaking
- micrograin grades with PVD coatings

Application

- finition
- usinage des alliages d'aluminium et de titane, des matières non-ferreuses, ainsi que des aciers inoxydables
- avance F = 0.015-0.20 mm / U

Anwendung

- Schlichtbearbeitung
- Bearbeitung von Aluminium und Titan, Nichteisenmetalle und rostfreiem Stahl
- Vorschub F = 0.015-0.20 mm / U

Application

- finishing
- machining of aluminium alloys, non-ferrous materials and stainless steel
- feed rate F = 0.015-0.20 mm / U

type
ENP-X8°

arête de coupe polie
polierte Schneidkante
polished cutting edge

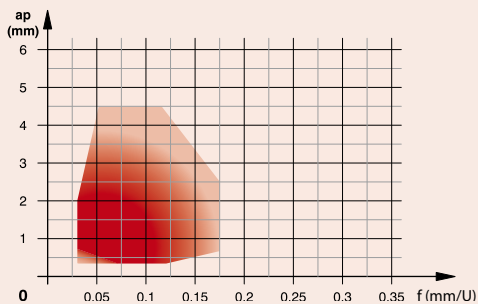
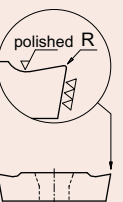

Matière
Werkstoff
Material

voir page :
siehe Seite :
see page :
3.03

Descriptif

- plaquette polie et rectifiée
- arête de coupe renforcée par polissage
- coupe positive 8° avec maîtrise des copeaux
- nuances micro-grain avec revêtements PVD

Beschreibung

- polierte und geschliffene Wendeplatte
- verstärkte und polierte Schneidkante
- 8° positiver Schnitt mit kontrolliertem Spanbruch
- Feinkornsorten mit PVD-Beschichtungen

Description

- polished and ground insert
- reinforced and polished cutting edge
- 8° positive cut with controlled chip-breaking
- micrograin grades with PVD coatings

Application

- finition et semi-finition
- usinage des aciers et aciers inoxydables
- avance F = 0.03-0.18 mm / U

Anwendung

- mittlere bis Schlichtbearbeitung
- für die Bearbeitung von Stahl und rostfreiem Stahl
- Vorschub F = 0.03-0.18 mm / U

Application

- finishing and semi-finishing
- steel and stainless steel machining
- feed rate F = 0.03-0.18 mm / U

type
ENP-X17°

arête de coupe polie
polierte Schneidkante
polished cutting edge

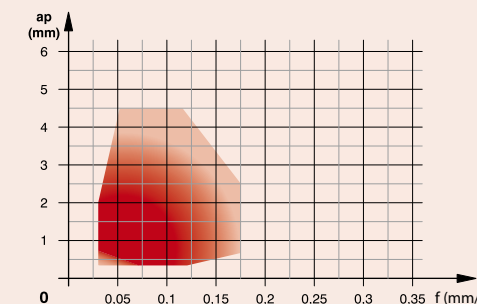
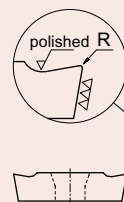

Matière
Werkstoff
Material

voir page :
siehe Seite :
see page :
3.03

Descriptif

- plaquette polie et rectifiée
- arête de coupe renforcée par polissage
- coupe positive 17° avec maîtrise des copeaux
- nuances micro-grain avec revêtements PVD

Beschreibung

- polierte und geschliffene Wendeplatte
- verstärkte und polierte Schneidkante
- 17° positiver Schnitt mit kontrolliertem Spanbruch
- Feinkornsorten mit PVD-Beschichtungen

Description

- polished and ground insert
- reinforced and polished cutting edge
- 17° positive cut with controlled chip-breaking
- micrograin grades with PVD coatings

Application

- finition et semi-finition
- usinage des aciers et aciers inoxydables
- avance F = 0.03-0.18 mm / U

Anwendung

- mittlere bis Schlichtbearbeitung
- für die Bearbeitung von Stahl und rostfreiem Stahl
- Vorschub F = 0.03-0.18 mm / U

Application

- finishing and semi-finishing
- steel and stainless steel machining
- feed rate F = 0.03-0.18 mm / U

Géométries de coupe
Spanformgeometrien
cutting geometries

type
FN-X25°

arête de coupe vive
scharfe Schneidkante
sharp cutting edge

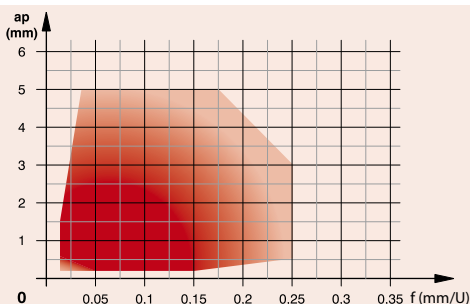
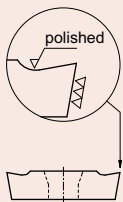

Matière
Werkstoff
Material



voir page :
siehe Seite :
see page :
3.03

Descriptif

- plaquette polie et rectifiée
- arête de coupe vive
- coupe positive 25° avec maîtrise des copeaux
- nuances micro-grain avec revêtements PVD

Beschreibung

- polierte und geschliffene Wendeplatte
- scharfe Schneidkante
- 25° positiver Schnitt mit kontrolliertem Spanbruch
- Feinkornsorten mit PVD-Beschichtungen

Description

- polished and ground insert
- sharp cutting edge
- 25° positive cut with controlled chip-breaking
- micrograin grades with PVD coatings

Application

- finition
- usinage des alliages d'aluminium et des matières non-ferreuses, ainsi que des aciers inoxydables
- avance F = 0.015-0.25 mm / U

Anwendung

- Schlichtbearbeitung
- Bearbeitung von Aluminium-Legierungen, Nichteisenmetalle und rostfreiem Stahl
- Vorschub F = 0.015-0.25 mm / U

Application

- finishing
- machining of aluminium alloys, non-ferrous materials and stainless steel
- feed rate F = 0.015-0.25 mm / U

type
ENP-X25°

arête de coupe polie
polierte Schneidkante
polished cutting edge

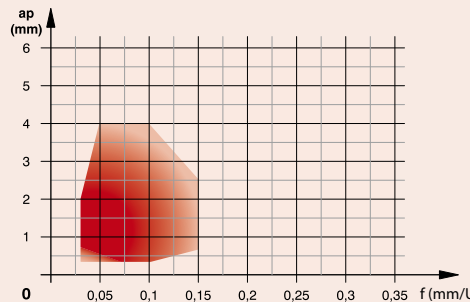
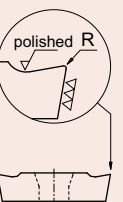

Matière
Werkstoff
Material



voir page :
siehe Seite :
see page :
3.03

Descriptif

- plaquette polie et rectifiée
- arête de coupe renforcée par polissage
- coupe positive 25° avec maîtrise des copeaux
- nuances micro-grain avec revêtements PVD

Beschreibung

- polierte und geschliffene Wendeplatte
- verstärkte und polierte Schneidkante
- 25° positiver Schnitt mit kontrolliertem Spanbruch
- Feinkornsorten mit PVD-Beschichtungen

Description

- polished and ground insert
- reinforced and polished cutting edge
- 25° positive cut with controlled chip-breaking
- micrograin grades with PVD coatings

Application

- finition et semi-finition
- usinage des aciers et aciers inoxydables
- avance F = 0.03-0.15 mm / U

Anwendung

- mittlere bis Schlichtbearbeitung
- für die Bearbeitung von Stahl und rostfreiem Stahl
- Vorschub F = 0.03-0.15 mm / U

Application

- finishing and semi-finishing
- steel and stainless steel machining
- feed rate F = 0.03-0.15 mm / U

Géométries de coupe
Spanformgeometrien
cutting geometries

type
FL/R-X10°

disponible uniquement en version 35° type VCGT-1103...
nur als 35°-Ausführung Typ VCGT-1103... erhältlich
available only in 35° execution type VCGT-1103...

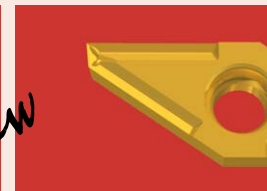

arête de coupe vive
scharfe Schneidkante
sharp cutting edge

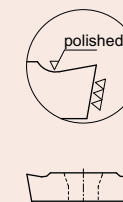

Matière
Werkstoff
Material



voir page :
siehe Seite :
see page :
3.03

rayon de plaquette dès 0.02 mm
Eckradius ab 0.02 mm
corner radius starting 0.02 mm

Descriptif

- plaquette polie et rectifiée
- arête de coupe vive
- coupe positive 10° avec maîtrise des copeaux
- nuances micro-grain avec revêtements PVD

Beschreibung

- polierte und geschliffene Wendeplatte
- scharfe Schneidkante
- 10° positiver Schnitt mit kontrolliertem Spanbruch
- Feinkornsorten mit PVD-Beschichtungen

Description

- polished and ground insert
- sharp cutting edge
- 10° positive cut with controlled chip-breaking
- micrograin grades with PVD coatings

Application

- finition
- géométrie universelle pour l'usinage de toutes matières
- avance F = 0.015-0.10 mm / U

Anwendung

- Schlichtbearbeitung
- allgemeine Geometrie für die Bearbeitung aller Werkstoffe
- Vorschub F = 0.015-0.10 mm / U

Application

- finishing
- general purpose geometry for the machining of all materials
- feed rate F = 0.015-0.10 mm / U

type
FN-K18°

disponible uniquement en version 35° type VCGT-1103...
nur in 35°-Ausführung Typ VCGT-1103... erhältlich
available only in 35° execution type VCGT-1103...

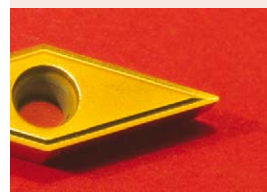

arête de coupe vive
scharfe Schneidkante
sharp cutting edge

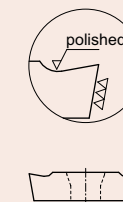

Matière
Werkstoff
Material



voir page :
siehe Seite :
see page :
3.03

Descriptif

- plaquette polie et rectifiée
- arête de coupe vive
- coupe positive 18° avec maîtrise des copeaux
- nuances micro-grain avec revêtements PVD

Beschreibung

- polierte und geschliffene Wendeplatte
- scharfe Schneidkante
- 18° positiver Schnitt mit kontrolliertem Spanbruch
- Feinkornsorten mit PVD-Beschichtungen

Description

- polished and ground insert
- sharp cutting edge
- 18° positive cut with controlled chip-breaking
- micrograin grades with PVD coatings

Application

- finition
- géométrie universelle pour l'usinage de toutes matières
- avance F = 0.01-0.10 mm / U

Anwendung

- Schlichtbearbeitung
- allgemeine Geometrie für die Bearbeitung aller Werkstoffe
- Vorschub F = 0.01-0.10 mm / U

Application

- finishing
- general purpose geometry for the machining of all materials
- feed rate F = 0.01-0.10 mm / U

Géométries de coupe
Spanformgeometrien
cutting geometries

type
FN-0°

disponible uniquement en version 35° type VCGW-1103...
nur in 35°-Ausführung Typ VCGW-1103... erhältlich
available only in 35° execution type VCGW-1103...

arête de coupe vive
scharfe Schneidkante
sharp cutting edge

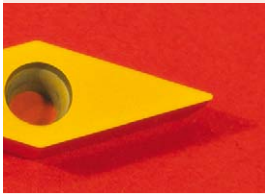

Descriptif <ul style="list-style-type: none"> plaquette polie et rectifiée arête de coupe vive coupe neutre 0° nuances micro-grain avec revêtements PVD 	Application <ul style="list-style-type: none"> finition usinage du laiton avance F = 0.01-0.10 mm / U
Beschreibung <ul style="list-style-type: none"> polierte und geschliffene Wendeplatte scharfe Schneidkante 0° neutral Schnitt Feinkornsorten mit PVD-Beschichtungen 	Anwendung <ul style="list-style-type: none"> mittlere bis Schlichtbearbeitung Messing-Bearbeitung Vorschub F = 0.01-0.10 mm / U
Description <ul style="list-style-type: none"> polished and ground insert sharp cutting edge neutral cut 0° micrograin grades with PVD coatings 	Application <ul style="list-style-type: none"> finishing and semi-finishing brass machining feed rate F = 0.01-0.10 mm / U

type
EN-XF

traitement d'arête minimum
kleinste Schneidkantebearbeitung
smallest cutting edge treatment

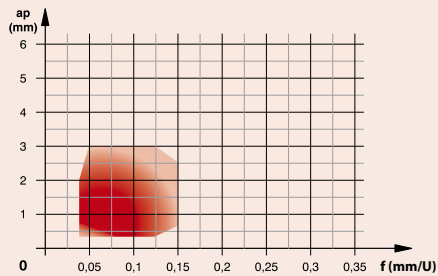
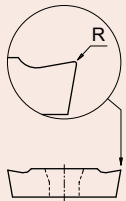

Matière
Werkstoff
Material



voir page :
siehe Seite :
see page :

3.03

Descriptif <ul style="list-style-type: none"> plaquette non rectifiée coupe positive avec maîtrise des copeaux traitement spécial permettant un rayon minimum des arêtes de coupe revêtements PVD et CVD 	Application <ul style="list-style-type: none"> finition et semi-finition usinage des aciers et aciers inoxydables avance F = 0.04-0.15 mm / U
Beschreibung <ul style="list-style-type: none"> ungeschliffene Wendeplatte positiver Schnitt mit kontrolliertem Spanbruch kleinste Schneidkanten-Abrundung durch Sonderbehandlungs-Prozess PVD und CVD Beschichtungen 	Anwendung <ul style="list-style-type: none"> mittlere bis Schlichtbearbeitung für die Bearbeitung von Stahl und rostfreiem Stahl Vorschub F = 0.04-0.15 mm / U
Description <ul style="list-style-type: none"> unground insert positive cut with controlled chip-breaking special treatment for smallest cutting edge rounding PVD and CVD coatings 	Application <ul style="list-style-type: none"> finishing and semi-finishing steel and stainless steel machining feed rate F = 0.04-0.15 mm / U

Géométries de coupe
Spanformgeometrien
cutting geometries

type
EN-MF

traitement d'arête
Schneidkante Behandlung
cutting edge treatment

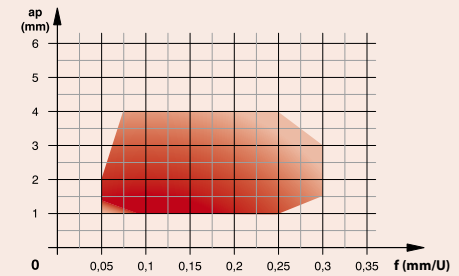
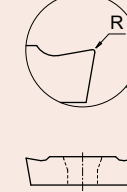

Matière
Werkstoff
Material



voir page :
siehe Seite :
see page :

3.03

Descriptif <ul style="list-style-type: none"> plaquette non rectifiée coupe positive avec maîtrise des copeaux traitement spécial des arêtes de coupe revêtements PVD et CVD 	Application <ul style="list-style-type: none"> travaux moyens usinage des aciers et aciers inoxydables avance F = 0.05-0.30 mm / U
Beschreibung <ul style="list-style-type: none"> ungeschliffene Wendeplatte positiver Schnitt mit kontrolliertem Spanbruch Schneidkanten-Abrundung durch Sonderbehandlungs-Prozess PVD und CVD Beschichtungen 	Anwendung <ul style="list-style-type: none"> Mittlere Bearbeitung für die Bearbeitung von Stahl und rostfreiem Stahl Vorschub F = 0.05-0.30 mm / U
Description <ul style="list-style-type: none"> unground insert positive cut with controlled chip-breaking special treatment for cutting edge rounding PVD and CVD coatings 	Application <ul style="list-style-type: none"> medium turning steel and stainless steel machining feed rate F = 0.05-0.30 mm / U

type
EN-HF

traitement d'arête
Schneidkante Behandlung
cutting edge treatment

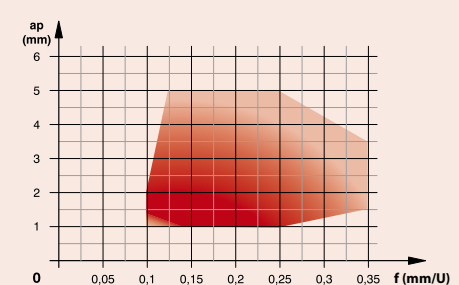
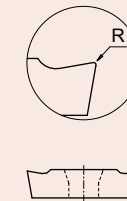
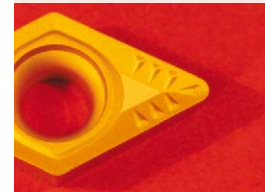

Matière
Werkstoff
Material



voir page :
siehe Seite :
see page :

3.03

Descriptif <ul style="list-style-type: none"> plaquette non rectifiée coupe positive avec maîtrise des copeaux traitement spécial des arêtes de coupe revêtement CVD 	Application <ul style="list-style-type: none"> travaux moyens et ébauche usinage des aciers et aciers inoxydables avance F = 0.1-0.35 mm / U
Beschreibung <ul style="list-style-type: none"> ungeschliffene Wendeplatte positiver Schnitt mit kontrolliertem Spanbruch Schneidkanten-Abrundung durch Sonderbehandlungs-Prozess CVD Beschichtung 	Anwendung <ul style="list-style-type: none"> Mittlere- und Schrupp-Bearbeitung für die Bearbeitung von Stahl und rostfreiem Stahl Vorschub F = 0.1-0.35 mm / U
Description <ul style="list-style-type: none"> unground insert positive cut with controlled chip-breaking special treatment for cutting edge rounding CVD coating 	Application <ul style="list-style-type: none"> medium turning and roughing steel and stainless steel machining feed rate F = 0.1-0.35 mm / U

Outils de tournage 80°
80°-Drehwerkzeuge
turning tools 80°

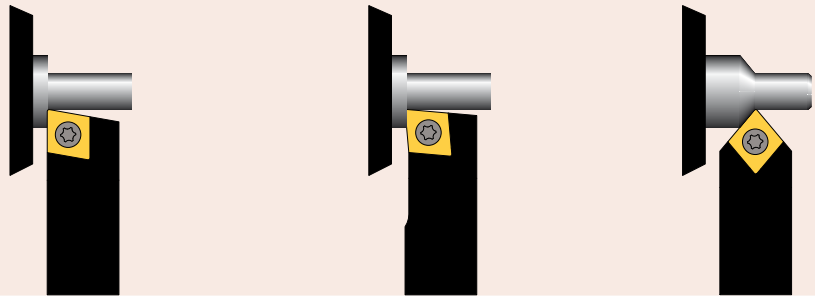

porte-outils
Halter
holders

L

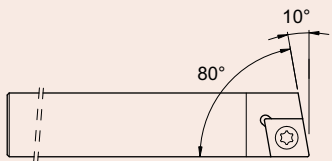

ISO-Code	Art. N°	Ø X L	Plaquette WSP insert
SCACL-0808X-06	ISO-2112	8 x 8 x 115	CC...0602..
SCACL-1010X-06	ISO-2113	10 x 10 x 115	CC...0602..
SCACL-1212X-06	ISO-2114	12 x 12 x 130	CC...0602..
SCACL-1212G-06	ISO-2114-90	12 x 12 x 90	CC...0602..
SCACL-1616X-06	ISO-2115	16 x 16 x 130	CC...0602..
SCACL-1616F-06	ISO-2115-75	16 x 16 x 75	CC...0602..
SCACL-1212X-09	ISO-2214	12 x 12 x 130	CC...09T3..
SCACL-1212G-09	ISO-2214-90	12 x 12 x 90	CC...09T3..
SCACL-1616X-09	ISO-2215	16 x 16 x 130	CC...09T3..
SCACL-1616F-09	ISO-2215-75	16 x 16 x 75	CC...09T3..
SCACL-2020X-09	ISO-2216	20 x 20 x 120	CC...09T3..

L

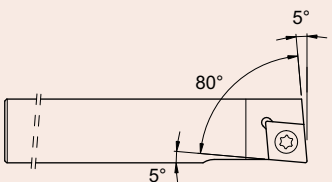

ISO-Code	Art. N°	Ø X L	Plaquette WSP insert
SCLCL-0808X-06	ISO-2132	8 x 8 x 115	CC...0602..
SCLCL-1010X-06	ISO-2133	10 x 10 x 115	CC...0602..
SCLCL-1212X-06	ISO-2134	12 x 12 x 130	CC...0602..
SCLCL-1212G-06	ISO-2134-90	12 x 12 x 90	CC...0602..
SCLCL-1616X-06	ISO-2135	16 x 16 x 130	CC...0602..
SCLCL-1616F-06	ISO-2135-75	16 x 16 x 75	CC...0602..
SCLCL-1212X-09	ISO-2234	12 x 12 x 130	CC...09T3..
SCLCL-1212G-09	ISO-2234-90	12 x 12 x 90	CC...09T3..
SCLCL-1616X-09	ISO-2235	16 x 16 x 130	CC...09T3..
SCLCL-1616F-09	ISO-2235-75	16 x 16 x 75	CC...09T3..
SCLCL-2020X-09	ISO-2236	20 x 20 x 120	CC...09T3..

porte-outils
Halter
holders

N

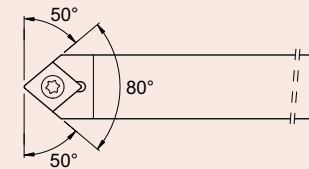

ISO-Code	Art. N°	Ø X L	Plaquette WSP insert
SCMCN-0808X-06	ISO-2102	8 x 8 x 115	CC...0602..
SCMCN-1010X-06	ISO-2103	10 x 10 x 115	CC...0602..
SCMCN-1212X-06	ISO-2104	12 x 12 x 130	CC...0602..
SCMCN-1212G-06	ISO-2104-90	12 x 12 x 90	CC...0602..
SCMCN-1616X-06	ISO-2105	16 x 16 x 130	CC...0602..
SCMCN-1616F-06	ISO-2105-75	16 x 16 x 75	CC...0602..
SCMCN-1212X-09	ISO-2204	12 x 12 x 130	CC...09T3..
SCMCN-1212G-09	ISO-2204-90	12 x 12 x 90	CC...09T3..
SCMCN-1616X-09	ISO-2205	16 x 16 x 130	CC...09T3..
SCMCN-1616F-09	ISO-2205-75	16 x 16 x 75	CC...09T3..
SCMCN-2020X-09	ISO-2206	20 x 20 x 120	CC...09T3..

R

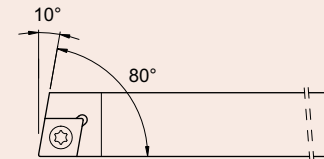

ISO-Code	Art. N°	Ø X L	Plaquette WSP insert
SCACR-0808X-06	ISO-2122	8 x 8 x 115	CC...0602..
SCACR-1010X-06	ISO-2123	10 x 10 x 115	CC...0602..
SCACR-1212X-06	ISO-2124	12 x 12 x 130	CC...0602..
SCACR-1212G-06	ISO-2124-90	12 x 12 x 90	CC...0602..
SCACR-1616X-06	ISO-2125	16 x 16 x 130	CC...0602..
SCACR-1616F-06	ISO-2125-75	16 x 16 x 75	CC...0602..
SCACR-1212X-09	ISO-2224	12 x 12 x 130	CC...09T3..
SCACR-1212G-09	ISO-2224-90	12 x 12 x 90	CC...09T3..
SCACR-1616X-09	ISO-2225	16 x 16 x 130	CC...09T3..
SCACR-1616F-09	ISO-2225-75	16 x 16 x 75	CC...09T3..
SCACR-2020X-09	ISO-2226	20 x 20 x 120	CC...09T3..

R

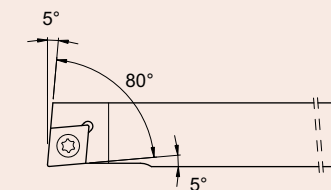

ISO-Code	Art. N°	Ø X L	Plaquette WSP insert
SCLCR-0808X-06	ISO-2142	8 x 8 x 115	CC...0602..
SCLCR-1010X-06	ISO-2143	10 x 10 x 115	CC...0602..
SCLCR-1212X-06	ISO-2144	12 x 12 x 130	CC...0602..
SCLCR-1212G-06	ISO-2144-90	12 x 12 x 90	CC...0602..
SCLCR-1616X-06	ISO-2145	16 x 16 x 130	CC...0602..
SCLCR-1616F-06	ISO-2145-75	16 x 16 x 75	CC...0602..
SCLCR-1212X-09	ISO-2244	12 x 12 x 130	CC...09T3..
SCLCR-1212G-09	ISO-2244-90	12 x 12 x 90	CC...09T3..
SCLCR-1616X-09	ISO-2245	16 x 16 x 130	CC...09T3..
SCLCR-1616F-09	ISO-2245-75	16 x 16 x 75	CC...09T3..
SCLCR-2020X-09	ISO-2246	20 x 20 x 120	CC...09T3..

Vis et clés de rechange
Ersatzschrauben und Schlüssel
Spare screws and keys

series ISO-2100	V-M2.5x7.8-T8		C-T8	
series ISO-2200	V-M4x9-T15-ISO		C-T15	

Plaquettes en métal dur
VHM-Wendeplatten
Solid carbide inserts

R	ISO-Code	Art. N°	revêtu / beschichtet / coated				non revêtu / unbeschichtet / uncoated		
			PVD				Ti3	K10 K20	
			TiN	TiAlN	HTA	Tmax			
CCGT									
0.05	CCGT-0602005-FN-X8	ISO-1130	■	■	■		■	■	
0.1	CCGT-060201-FN-X8	ISO-1131	■	■	■		■	■	
0.2	CCGT-060202-FN-X8	ISO-1132	■	■	■		■	■	
0.4	CCGT-060204-FN-X8	ISO-1134	■	■	■		■	■	
FN-X8°									
0.05	CCGT-09T3005-FN-X8	ISO-1230	■	■	■		■	■	
0.1	CCGT-09T301-FN-X8	ISO-1231	■	■	■		■	■	
0.2	CCGT-09T302-FN-X8	ISO-1232	■	■	■		■	■	
0.4	CCGT-09T304-FN-X8	ISO-1234	■	■	■		■	■	
ENP-X8°									
0.05	CCGT-0602005-ENP-X8	ISO-1130-P	□	■				□	
0.1	CCGT-060201-ENP-X8	ISO-1131-P	□	■				□	
0.2	CCGT-060202-ENP-X8	ISO-1132-P	□	■				□	
0.4	CCGT-060204-ENP-X8	ISO-1134-P	□	■				□	
0.05	CCGT-09T3005-ENP-X8	ISO-1230-P	□	■				□	
0.1	CCGT-09T301-ENP-X8	ISO-1231-P	□	■				□	
0.2	CCGT-09T302-ENP-X8	ISO-1232-P	□	■				□	
0.4	CCGT-09T304-ENP-X8	ISO-1234-P	□	■				□	
FN-X17°									
0.05	CCGT-0602005-FN-X17	ISO-1140	■	■	■		■	■	
0.1	CCGT-060201-FN-X17	ISO-1141	■	■	■		■	■	
0.2	CCGT-060202-FN-X17	ISO-1142	■	■	■		■	■	
0.4	CCGT-060204-FN-X17	ISO-1144	■	■	■		■	■	
0.05	CCGT-09T3005-FN-X17	ISO-1240	■	■	■		■	■	
0.1	CCGT-09T301-FN-X17	ISO-1241	■	■	■		■	■	
0.2	CCGT-09T302-FN-X17	ISO-1242	■	■	■		■	■	
0.4	CCGT-09T304-FN-X17	ISO-1244	■	■	■		■	■	
0.8	CCGT-09T308-FN-X17	ISO-1248	■	■	■		■	■	
ENP-X17°									
0.05	CCGT-0602005-ENP-X17	ISO-1140-P	□	■				□	
0.1	CCGT-060201-ENP-X17	ISO-1141-P	□	■				□	
0.2	CCGT-060202-ENP-X17	ISO-1142-P	□	■				□	
0.4	CCGT-060204-ENP-X17	ISO-1144-P	□	■				□	
0.05	CCGT-09T3005-ENP-X17	ISO-1240-P	□	■				□	
0.1	CCGT-09T301-ENP-X17	ISO-1241-P	□	■				□	
0.2	CCGT-09T302-ENP-X17	ISO-1242-P	□	■				□	
0.4	CCGT-09T304-ENP-X17	ISO-1244-P	□	■				□	
0.8	CCGT-09T308-ENP-X17	ISO-1248-P	□	■				□	

■ = Disponible / Verfügbar / Available

□ = Avec délai de livraison / Mit Lieferfrist / Available with delivery time

Plaquettes en métal dur
VHM-Wendeplatten
Solid carbide inserts

R	ISO-Code	Art. N°	revêtu / beschichtet / coated				non revêtu / unbeschichtet / uncoated		
			PVD				Ti3	K10 K20	
			TiN	TiAlN	HTA	Tmax			
CCGT									
0.05	CCGT-0602005-FN-X25	ISO-1150	■	■	■		■	■	
0.1	CCGT-060201-FN-X25	ISO-1151	■	■	■		■	■	
0.2	CCGT-060202-FN-X25	ISO-1152	■	■	■		■	■	
0.4	CCGT-060204-FN-X25	ISO-1154	■	■	■		■	■	
FN-X25°									
0.05	CCGT-09T3005-FN-X25	ISO-1250	■	■	■		■	■	
0.1	CCGT-09T301-FN-X25	ISO-1251	■	■	■		■	■	
0.2	CCGT-09T302-FN-X25	ISO-1252	■	■	■		■	■	
0.4	CCGT-09T304-FN-X25	ISO-1254	■	■	■		■	■	
0.8	CCGT-09T308-FN-X25	ISO-1258	■	■	■		■	■	
ENP-X25°									
0.05	CCGT-0602005-ENP-X25	ISO-1150-P	□	■				□	
0.1	CCGT-060201-ENP-X25	ISO-1151-P	□	■				□	
0.2	CCGT-060202-ENP-X25	ISO-1152-P	□	■				□	
0.4	CCGT-060204-ENP-X25	ISO-1154-P	□	■				□	
0.05	CCGT-09T3005-ENP-X25	ISO-1250-P	□	■				□	
0.1	CCGT-09T301-ENP-X25	ISO-1251-P	□	■				□	
0.2	CCGT-09T302-ENP-X25	ISO-1252-P	□	■				□	
0.4	CCGT-09T304-ENP-X25	ISO-1254-P	□	■				□	
0.8	CCGT-09T308-ENP-X25	ISO-1258-P	□	■				□	
CCMT									
0.2	CCMT-060202-EN-XF	ISO-1112	■	■		■			
0.4	CCMT-060204-EN-XF	ISO-1114	■	■		■			
EN-XF									
0.2	CCMT-09T302-EN-XF	ISO-1212	■	■		■			
0.4	CCMT-09T304-EN-XF	ISO-1214	■	■		■			
0.8	CCMT-09T308-EN-XF	ISO-1218	■	■		■			
EN-MF									
0.2	CCMT-060202-EN-MF	ISO-1122	■	■	■	■			
0.4	CCMT-060204-EN-MF	ISO-1124	■	■	■	■			
EN-HF									
0.4	CCMT-060204-EN-HF	ISO-1194				■			
0.8	CCMT-060208-EN-HF	ISO-1198				■			
EN-HF									
0.4	CCMT-09T304-EN-HF	ISO-1294				■			
0.8	CCMT-09T308-EN-HF	ISO-1298				■			

Outils de tournage 55°
55°-Drehwerkzeuge
turning tools 55°

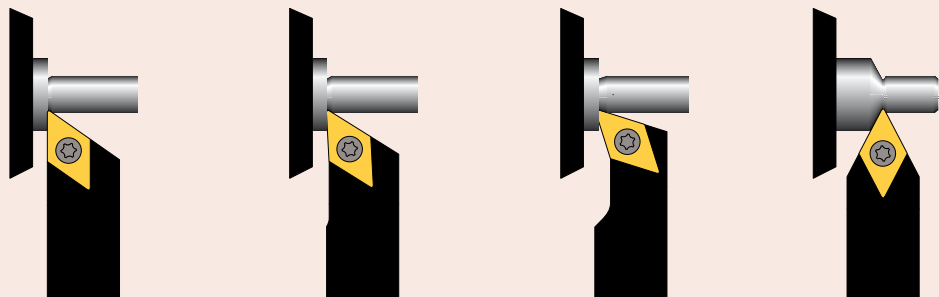

porte-outils
Halter
holders

L

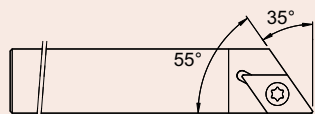

ISO-Code	Art. N°	Ø X L	Plaquette WSP insert
SDACL-0808X-07	ISO-2312	8 x 8 x 115	DC..-0702..
SDACL-1010X-07	ISO-2313	10 x 10 x 115	DC..-0702..
SDACL-1212X-07	ISO-2314	12 x 12 x 130	DC..-0702..
SDACL-1212G-07	ISO-2314-90	12 x 12 x 90	DC..-0702..
SDACL-1616X-07	ISO-2315	16 x 16 x 130	DC..-0702..
SDACL-1616F-07	ISO-2315-75	16 x 16 x 75	DC..-0702..
SDACL-1212X-11	ISO-2414	12 x 12 x 130	DC..-11T3..
SDACL-1212G-11	ISO-2414-90	12 x 12 x 90	DC..-11T3..
SDACL-1616X-11	ISO-2415	16 x 16 x 130	DC..-11T3..
SDACL-1616F-11	ISO-2415-75	16 x 16 x 75	DC..-11T3..
SDACL-2020X-11	ISO-2416	20 x 20 x 120	DC..-11T3..

L

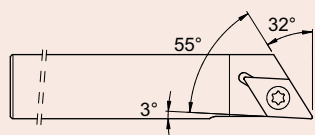

ISO-Code	Art. N°	Ø X L	Plaquette WSP insert
SDJCL-0808X-07	ISO-2332	8 x 8 x 115	DC..-0702..
SDJCL-1010X-07	ISO-2333	10 x 10 x 115	DC..-0702..
SDJCL-1212X-07	ISO-2334	12 x 12 x 130	DC..-0702..
SDJCL-1212G-07	ISO-2334-90	12 x 12 x 90	DC..-0702..
SDJCL-1616X-07	ISO-2335	16 x 16 x 130	DC..-0702..
SDJCL-1616F-07	ISO-2335-75	16 x 16 x 75	DC..-0702..
SDJCL-2020X-07	ISO-2336	20 x 20 x 120	DC..-0702..
SDJCL-1212X-11	ISO-2434	12 x 12 x 130	DC..-11T3..
SDJCL-1212G-11	ISO-2434-90	12 x 12 x 90	DC..-11T3..
SDJCL-1616X-11	ISO-2435	16 x 16 x 130	DC..-11T3..
SDJCL-1616F-11	ISO-2435-75	16 x 16 x 75	DC..-11T3..
SDJCL-2020X-11	ISO-2436	20 x 20 x 120	DC..-11T3..

porte-outils
Halter
holders

N

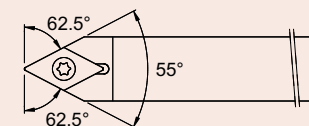

ISO-Code	Art. N°	Ø X L	Plaquette WSP insert
SDNCN-0808X-07	ISO-2302	8 x 8 x 115	DC..-0702..
SDNCN-1010X-07	ISO-2303	10 x 10 x 115	DC..-0702..
SDNCN-1212X-07	ISO-2304	12 x 12 x 130	DC..-0702..
SDNCN-1212G-07	ISO-2304-90	12 x 12 x 90	DC..-0702..
SDNCN-1616X-07	ISO-2305	16 x 16 x 130	DC..-0702..
SDNCN-1616F-07	ISO-2305-75	16 x 16 x 75	DC..-0702..
SDNCN-1212X-11	ISO-2404	12 x 12 x 130	DC..-11T3..
SDNCN-1212G-11	ISO-2404-90	12 x 12 x 90	DC..-11T3..
SDNCN-1616X-11	ISO-2405	16 x 16 x 130	DC..-11T3..
SDNCN-1616F-11	ISO-2405-75	16 x 16 x 75	DC..-11T3..
SDNCN-2020X-11	ISO-2406	20 x 20 x 120	DC..-11T3..

R

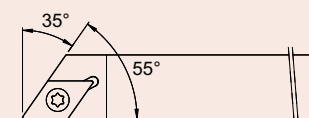

ISO-Code	Art. N°	Ø X L	Plaquette WSP insert
SDACR-0808X-07	ISO-2322	8 x 8 x 115	DC..-0702..
SDACR-1010X-07	ISO-2323	10 x 10 x 115	DC..-0702..
SDACR-1212X-07	ISO-2324	12 x 12 x 130	DC..-0702..
SDACR-1212G-07	ISO-2324-90	12 x 12 x 90	DC..-0702..
SDACR-1616X-07	ISO-2325	16 x 16 x 130	DC..-0702..
SDACR-1616F-07	ISO-2325-75	16 x 16 x 75	DC..-0702..
SDACR-1212X-11	ISO-2424	12 x 12 x 130	DC..-11T3..
SDACR-1212G-11	ISO-2424-90	12 x 12 x 90	DC..-11T3..
SDACR-1616X-11	ISO-2425	16 x 16 x 130	DC..-11T3..
SDACR-1616F-11	ISO-2425-75	16 x 16 x 75	DC..-11T3..
SDACR-2020X-11	ISO-2426	20 x 20 x 120	DC..-11T3..

R

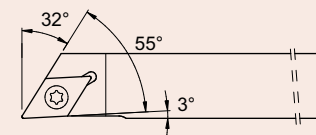

ISO-Code	Art. N°	Ø X L	Plaquette WSP insert
SDJCR-0808X-07	ISO-2342	8 x 8 x 115	DC..-0702..
SDJCR-1010X-07	ISO-2343	10 x 10 x 115	DC..-0702..
SDJCR-1212X-07	ISO-2344	12 x 12 x 130	DC..-0702..
SDJCR-1212G-07	ISO-2344-90	12 x 12 x 90	DC..-0702..
SDJCR-1616X-07	ISO-2345	16 x 16 x 130	DC..-0702..
SDJCR-1616F-07	ISO-2345-75	16 x 16 x 75	DC..-0702..
SDJCR-2020X-07	ISO-2346	20 x 20 x 120	DC..-0702..
SDJCR-1212X-11	ISO-2444	12 x 12 x 130	DC..-11T3..
SDJCR-1212G-11	ISO-2444-90	12 x 12 x 90	DC..-11T3..
SDJCR-1616X-11	ISO-2445	16 x 16 x 130	DC..-11T3..
SDLCR-1616F-11	ISO-2445-75	16 x 16 x 75	DC..-11T3..
SDJCR-2020X-11	ISO-2446	20 x 20 x 120	DC..-11T3..

porte-outils
Halter
holders

L

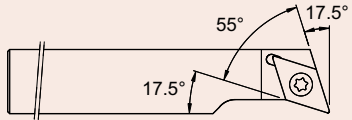

ISO-Code	Art. N°	∅ X L	Plaquette WSP insert
SDHCL-1010X-07	ISO-2353	10 x 10 x 115	DC..-0702..
SDHCL-1212X-07	ISO-2354	12 x 12 x 130	DC..-0702..
SDHCL-1212G-07	ISO-2354-90	12 x 12 x 90	DC..-0702..
SDHCL-1616X-07	ISO-2355	16 x 16 x 130	DC..-0702..
SDHCL-1616F-07	ISO-2355-75	16 x 16 x 75	DC..-0702..

SDHCL-1616X-11	ISO-2455	16 x 16 x 130	DC..-11T3..
SDHCL-1616F-11	ISO-2455-75	16 x 16 x 75	DC..-11T3..
SDHCL-2020X-11	ISO-2456	20 x 20 x 120	DC..-11T3..

porte-outils
Halter
holders

R

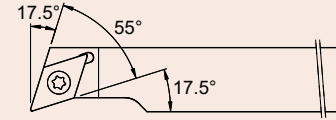

ISO-Code	Art. N°	∅ X L	Plaquette WSP insert
SDHCR-1010X-07	ISO-2363	10 x 10 x 115	DC..-0702..
SDHCR-1212X-07	ISO-2364	12 x 12 x 130	DC..-0702..
SDHCR-1212G-07	ISO-2364-90	12 x 12 x 90	DC..-0702..
SDHCR-1616X-07	ISO-2365	16 x 16 x 130	DC..-0702..
SDHCR-1616F-07	ISO-2365-75	16 x 16 x 75	DC..-0702..

SDHCR-1616X-11	ISO-2465	16 x 16 x 130	DC..-11T3..
SDHCR-1616F-11	ISO-2465-75	16 x 16 x 75	DC..-11T3..
SDHCR-2020X-11	ISO-2466	20 x 20 x 120	DC..-11T3..

L / R

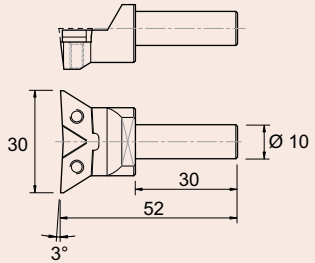

Art. N°	Plaquette WSP insert
ISO-2400-D10	DC..-11T3..

L / R

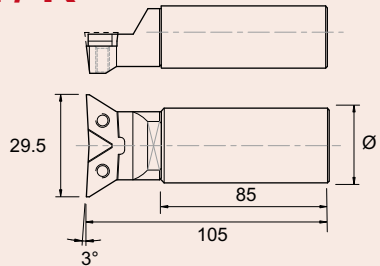

new

∅	Art. N°	Plaquette WSP insert
20	ISO-2400-D20-S	DC..-11T3..
25.4	ISO-2400-D25.4-S	DC..-11T3..

Vis et clés de rechange
Ersatzschrauben und Schlüssel
Spare screws and keys

series ISO-2300	V-M2.5x7.8-T8		C-T8	
series ISO-2400	V-M4x9-T15-ISO		C-T15	

Plaquettes en métal dur
VHM-Wendepplatten
Solid carbide inserts

R	ISO-Code	Art. N°	revêtu / beschichtet / coated				non revêtu / unbeschichtet / uncoated		
			PVD				CVD	K10	K20
			TiN	TiAlN	HTA	Tmax			
0.05	DCGT-0702005-FN-X8	ISO-1330	■	■	■		■	■	
0.1	DCGT-070201-FN-X8	ISO-1331	■	■	■		■	■	
0.2	DCGT-070202-FN-X8	ISO-1332	■	■	■		■	■	
0.4	DCGT-070204-FN-X8	ISO-1334	■	■	■		■	■	
0.05	DCGT-11T3005-FN-X8	ISO-1430	■	■	■		■	■	
0.1	DCGT-11T301-FN-X8	ISO-1431	■	■	■		■	■	
0.2	DCGT-11T302-FN-X8	ISO-1432	■	■	■		■	■	
0.4	DCGT-11T304-FN-X8	ISO-1434	■	■	■		■	■	
0.05	DCGT-0702005-ENP-X8	ISO-1330-P	□	■				□	
0.1	DCGT-070201-ENP-X8	ISO-1331-P	□	■				□	
0.2	DCGT-070202-ENP-X8	ISO-1332-P	□	■				□	
0.4	DCGT-070204-ENP-X8	ISO-1334-P	□	■				□	
0.05	DCGT-11T3005-ENP-X8	ISO-1430-P	□	■				□	
0.1	DCGT-11T301-ENP-X8	ISO-1431-P	□	■				□	
0.2	DCGT-11T302-ENP-X8	ISO-1432-P	□	■				□	
0.4	DCGT-11T304-ENP-X8	ISO-1434-P	□	■				□	
0.05	DCGT-0702005-FN-X17	ISO-1340	■	■	■		■	■	
0.1	DCGT-070201-FN-X17	ISO-1341	■	■	■		■	■	
0.2	DCGT-070202-FN-X17	ISO-1342	■	■	■		■	■	
0.4	DCGT-070204-FN-X17	ISO-1344	■	■	■		■	■	
0.05	DCGT-11T3005FN-X17	ISO-1440	■	■	■		■	■	
0.1	DCGT-11T301-FN-X17	ISO-1441	■	■	■		■	■	
0.2	DCGT-11T302-FN-X17	ISO-1442	■	■	■		■	■	
0.4	DCGT-11T304-FN-X17	ISO-1444	■	■	■		■	■	
0.8	DCGT-11T308-FN-X17	ISO-1448	■	■	■		■	■	
0.05	DCGT-0702005-ENP-X17	ISO-1340-P	□	■				□	
0.1	DCGT-070201-ENP-X17	ISO-1341-P	□	■				□	
0.2	DCGT-070202-ENP-X17	ISO-1342-P	□	■				□	
0.4	DCGT-070204-ENP-X17	ISO-1344-P	□	■				□	
0.05	DCGT-11T3005-ENP-X17	ISO-1440-P	□	■				□	
0.1	DCGT-11T301-ENP-X17	ISO-1441-P	□	■				□	
0.2	DCGT-11T302-ENP-X17	ISO-1442-P	□	■				□	
0.4	DCGT-11T304-ENP-X17	ISO-1444-P	□	■				□	
0.8	DCGT-11T308-ENP-X17	ISO-1448-P	□	■				□	

■ = Disponible / Verfügbar / Available

□ = Avec délai de livraison / Mit Lieferfrist / Available with delivery time

Plaquettes en métal dur
VHM-Wendepplatten
Solid carbide inserts

R	ISO-Code	Art. N°	revêtu / beschichtet / coated				non revêtu / unbeschichtet / uncoated		
			PVD				CVD	K10	K20
			TiN	TiAlN	HTA	Tmax			
0.05	DCGT-0702005-FN-X25	ISO-1350	■	■	■		■	■	
0.1	DCGT-070201-FN-X25	ISO-1351	■	■	■		■	■	
0.2	DCGT-070202-FN-X25	ISO-1352	■	■	■		■	■	
0.4	DCGT-070204-FN-X25	ISO-1354	■	■	■		■	■	
0.05	DCGT-11T3005-FN-X25	ISO-1450	■	■	■		■	■	
0.1	DCGT-11T301-FN-X25	ISO-1451	■	■	■		■	■	
0.2	DCGT-11T302-FN-X25	ISO-1452	■	■	■		■	■	
0.4	DCGT-11T304-FN-X25	ISO-1454	■	■	■		■	■	
0.8	DCGT-11T308-FN-X25	ISO-1458	■	■	■		■	■	
0.05	DCGT-0702005-ENP-X25	ISO-1350-P	□	■				□	
0.1	DCGT-070201-ENP-X25	ISO-1351-P	□	■				□	
0.2	DCGT-070202-ENP-X25	ISO-1352-P	□	■				□	
0.4	DCGT-070204-ENP-X25	ISO-1354-P	□	■				□	
0.05	DCGT-11T3005-ENP-X25	ISO-1450-P	□	■				□	
0.1	DCGT-11T301-ENP-X25	ISO-1451-P	□	■				□	
0.2	DCGT-11T302-ENP-X25	ISO-1452-P	□	■				□	
0.4	DCGT-11T304-ENP-X25	ISO-1454-P	□	■				□	
0.8	DCGT-11T308-ENP-X25	ISO-1458-P	□	■				□	
0.2	DCMT-070202-EN-XF	ISO-1312	■	■			■		
0.4	DCMT-070204-EN-XF	ISO-1314	■	■			■		
0.2	DCMT-11T302-EN-XF	ISO-1412	■	■			■		
0.4	DCMT-11T304-EN-XF	ISO-1414	■	■			■		
0.8	DCMT-11T308-EN-XF	ISO-1418	■	■			■		
0.2	DCMT-070202-EN-MF	ISO-1322	■	■	■		■		
0.4	DCMT-070204-EN-MF	ISO-1324	■	■	■		■		
0.2	DCMT-11T302-EN-MF	ISO-1422	■	■	■		■		
0.4	DCMT-11T304-EN-MF	ISO-1424	■	■	■		■		
0.8	DCMT-11T308-EN-MF	ISO-1428	■	■	■		■		
0.4	DCMT-070204-EN-HF	ISO-1394					■		
0.8	DCMT-070208-EN-HF	ISO-1398					■		
0.4	DCMT-11T304-EN-HF	ISO-1494					■		
0.8	DCMT-11T308-EN-HF	ISO-1498					■		

DCGT



FN-X25°



DCGT



ENP-X25°



DCMT



EN-XF



DCMT



EN-MF



DCMT



EN-HF



Outils de tournage 35°
35°-Drehwerkzeuge
turning tools 35°

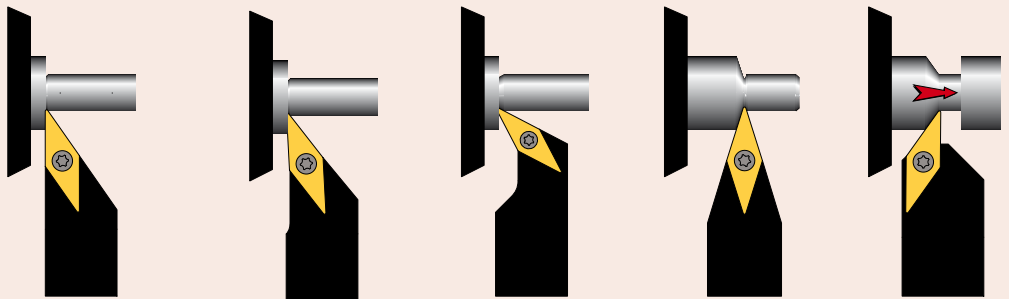

porte-outils
Halter
holders

L

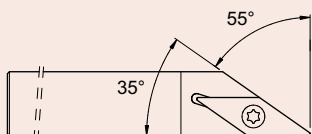

ISO-Code	Art. N°	Ø X L	Plaquette WSP insert
SVACL-0808X-11	ISO-2612	8 x 8 x 115	VC...-1103..
SVACL-1010X-11	ISO-2613	10 x 10 x 115	VC...-1103..
SVACL-1212X-11	ISO-2614	12 x 12 x 130	VC...-1103..
SVACL-1212G-11	ISO-2614-90	12 x 12 x 90	VC...-1103..
SVACL-1616X-11	ISO-2615	16 x 16 x 130	VC...-1103..
SVACL-1616F-11	ISO-2615-75	16 x 16 x 75	VC...-1103..
SVACL-2020X-11	ISO-2616	20 x 20 x 120	VC...-1103..
SVACL-1212X-16	ISO-2714	12 x 12 x 130	VC...-1604..
SVACL-1212G-16	ISO-2714-90	12 x 12 x 90	VC...-1604..
SVACL-1616X-16	ISO-2715	16 x 16 x 130	VC...-1604..
SVACL-1616F-16	ISO-2715-75	16 x 16 x 75	VC...-1604..
SVACL-2020X-16	ISO-2716	20 x 20 x 120	VC...-1604..

L

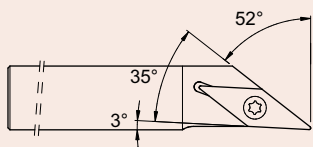

ISO-Code	Art. N°	Ø X L	Plaquette WSP insert
SVJCL-0808X-11	ISO-2632	8 x 8 x 115	VC...-1103..
SVJCL-1010X-11	ISO-2633	10 x 10 x 115	VC...-1103..
SVJCL-1212X-11	ISO-2634	12 x 12 x 130	VC...-1103..
SVJCL-1212G-11	ISO-2634-90	12 x 12 x 90	VC...-1103..
SVJCL-1616X-11	ISO-2635	16 x 16 x 130	VC...-1103..
SVJCL-1616F-11	ISO-2635-75	16 x 16 x 75	VC...-1103..
SVJCL-2020X-11	ISO-2636	20 x 20 x 120	VC...-1103..
SVJCL-1212X-16	ISO-2734	12 x 12 x 130	VC...-1604..
SVJCL-1212G-16	ISO-2734-90	12 x 12 x 90	VC...-1604..
SVJCL-1616X-16	ISO-2735	16 x 16 x 130	VC...-1604..
SVLCL-1616F-16	ISO-2735-75	16 x 16 x 75	VC...-1604..
SVJCL-2020X-16	ISO-2736	20 x 20 x 120	VC...-1604..

porte-outils
Halter
holders

N

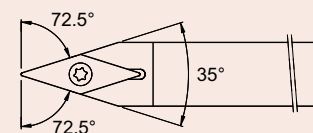

ISO-Code	Art. N°	Ø X L	Plaquette WSP insert
SVVCN-0808X-11	ISO-2602	8 x 8 x 115	VC...-1103..
SVVCN-1010X-11	ISO-2603	10 x 10 x 115	VC...-1103..
SVVCN-1212X-11	ISO-2604	12 x 12 x 130	VC...-1103..
SVVCN-1212G-11	ISO-2604-90	12 x 12 x 90	VC...-1103..
SVVCN-1616X-11	ISO-2605	16 x 16 x 130	VC...-1103..
SVVCN-1616F-11	ISO-2605-75	16 x 16 x 75	VC...-1103..
SVVCN-2020X-11	ISO-2606	20 x 20 x 120	VC...-1103..
SVVCN-1212X-16	ISO-2704	12 x 12 x 130	VC...-1604..
SVVCN-1212G-16	ISO-2704-90	12 x 12 x 90	VC...-1604..
SVVCN-1616X-16	ISO-2705	16 x 16 x 130	VC...-1604..
SVVCN-1616F-16	ISO-2705-75	16 x 16 x 75	VC...-1604..
SVVCN-2020X-16	ISO-2706	20 x 20 x 120	VC...-1604..

R

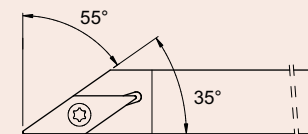

ISO-Code	Art. N°	Ø X L	Plaquette WSP insert
SVACR-0808X-11	ISO-2622	8 x 8 x 115	VC...-1103..
SVACR-1010X-11	ISO-2623	10 x 10 x 115	VC...-1103..
SVACR-1212X-11	ISO-2624	12 x 12 x 130	VC...-1103..
SVACR-1212G-11	ISO-2624-90	12 x 12 x 90	VC...-1103..
SVACR-1616X-11	ISO-2625	16 x 16 x 130	VC...-1103..
SVACR-1616F-11	ISO-2625-75	16 x 16 x 75	VC...-1103..
SVACR-2020X-11	ISO-2626	20 x 20 x 120	VC...-1103..
SVACR-1212X-16	ISO-2724	12 x 12 x 130	VC...-1604..
SVACR-1212G-16	ISO-2724-90	12 x 12 x 90	VC...-1604..
SVACR-1616X-16	ISO-2725	16 x 16 x 130	VC...-1604..
SVACR-1616F-16	ISO-2725-75	16 x 16 x 75	VC...-1604..
SVACR-2020X-16	ISO-2726	20 x 20 x 120	VC...-1604..

R

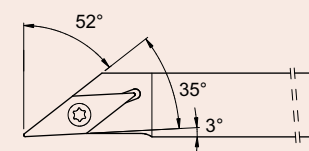

ISO-Code	Art. N°	Ø X L	Plaquette WSP insert
SVJCR-0808X-11	ISO-2642	8 x 8 x 115	VC...-1103..
SVJCR-1010X-11	ISO-2643	10 x 10 x 115	VC...-1103..
SVJCR-1212X-11	ISO-2644	12 x 12 x 130	VC...-1103..
SVJCR-1212G-11	ISO-2644-90	12 x 12 x 90	VC...-1103..
SVJCR-1616X-11	ISO-2645	16 x 16 x 130	VC...-1103..
SVJCR-1616F-11	ISO-2645-75	16 x 16 x 75	VC...-1103..
SVJCR-2020X-11	ISO-2646	20 x 20 x 120	VC...-1103..
SVJCR-1212X-16	ISO-2744	12 x 12 x 130	VC...-1604..
SVJCR-1212G-16	ISO-2744-90	12 x 12 x 90	VC...-1604..
SVJCR-1616X-16	ISO-2745	16 x 16 x 130	VC...-1604..
SVLCR-1616F-16	ISO-2745-75	16 x 16 x 75	VC...-1604..
SVJCR-2020X-16	ISO-2746	20 x 20 x 120	VC...-1604..

porte-outils
Halter
holders

R

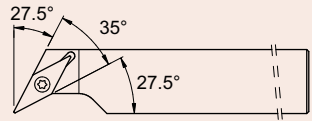

ISO-Code	Art. N°	Ø X L	Plaquette WSP insert
SVXCR-1616X-11	ISO-2665	16 x 16 x 130	VC...-1103..
SVXCR-1616F-11	ISO-2665-75	16 x 16 x 75	VC...-1103..
SVXCR-2020X-11	ISO-2666	20 x 20 x 120	VC...-1103..

R

tourneur arrière
rückwärts drehen
back turning

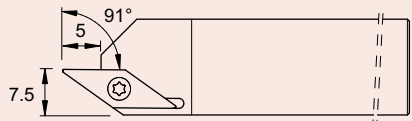

ISO-Code	Art. N°	Ø X L	Plaquette WSP insert
SV-CR-1212X-11	ISO-2684	12 x 12 x 130	VCG...-1103..
SV-CR-1212G-11	ISO-2684-90	12 x 12 x 90	VCG...-1103..
SV-CR-1616X-11	ISO-2685	16 x 16 x 130	VCG...-1103..
SV-CR-1616F-11	ISO-2685-75	16 x 16 x 75	VCG...-1103..
SV-CR-2020X-11	ISO-2686	20 x 20 x 120	VCG...-1103..

L

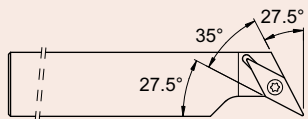

ISO-Code	Art. N°	Ø X L	Plaquette WSP insert
SVXCL-1616X-11	ISO-2655	16 x 16 x 130	VC...-1103..
SVXCL-1616F-11	ISO-2655-75	16 x 16 x 75	VC...-1103..
SVXCL-2020X-11	ISO-2656	20 x 20 x 120	VC...-1103..

L

tourneur arrière
rückwärts drehen
back turning

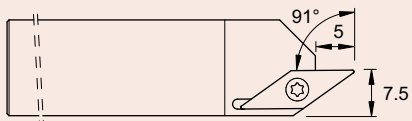

ISO-Code	Art. N°	Ø X L	Plaquette WSP insert
SV-CL-1212X-11	ISO-2674	12 x 12 x 130	VCG...-1103..
SV-CL-1212G-11	ISO-2674-90	12 x 12 x 90	VCG...-1103..
SV-CL-1616X-11	ISO-2675	16 x 16 x 130	VCG...-1103..
SV-CL-1616F-11	ISO-2675-75	16 x 16 x 75	VCG...-1103..
SV-CL-2020X-11	ISO-2676	20 x 20 x 120	VCG...-1103..

Vis et clés de rechange
Ersatzschrauben und Schlüssel
Spare screws and keys

series ISO-2600

V-M2.5x7.8-T8



C-T8

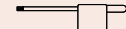

series ISO-2700

V-M4x9-T15-ISO



C-T15

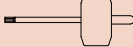

Plaquettes en métal dur
VHM-Wendeplatten
Solid carbide inserts

L/R

new

VCGT-R



FR-X10°

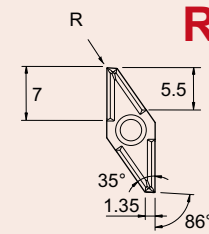

R	ISO-Code	Art. N°	PVD				CVD	non revêtu unbeschichtet uncoated	
			TiN	TiAlN	HTA	Tmax	Ti3	K10	K20
0.03	VCGT-1103003-FR-X10	ISO-1690-R	■	■	■			■	■
0.08	VCGT-1103008-FR-X10	ISO-16908-R	■	■	■			■	■
0.1	VCGT-110301-FR-X10	ISO-1691-R	■	■	■			■	■
0.2	VCGT-110302-FR-X10	ISO-1692-R	■	■	■			■	■

VCGT-L



FL-X10°

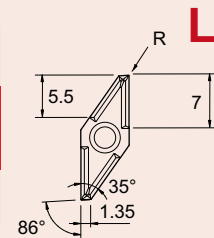

R	ISO-Code	Art. N°	PVD				CVD	non revêtu unbeschichtet uncoated	
			TiN	TiAlN	HTA	Tmax	Ti3	K10	K20
0.03	VCGT-1103003-FL-X10	ISO-1690-L	■	■	■			■	■
0.08	VCGT-1103008-FL-X10	ISO-16908-L	■	■	■			■	■
0.1	VCGT-110301-FL-X10	ISO-1691-L	■	■	■			■	■
0.2	VCGT-110302-FL-X10	ISO-1692-L	■	■	■			■	■

Porte-outils compatibles avec plaquettes ISO-169x-L/R
Passende Halter zu den Wendeplatten ISO-169x-L/R
Holder compatible with inserts ISO-169x-L/R

R

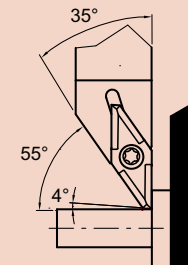

ISO-Code	Art. N°
SVACR-...-11	ISO-262x

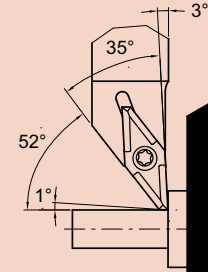

ISO-Code	Art. N°
SVJCR-...-11	ISO-264x

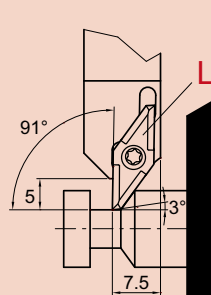

ISO-Code	Art. N°
SV-CR-...-11	ISO-268x

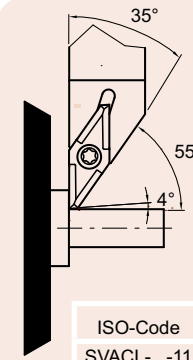

ISO-Code	Art. N°
SVACL-...-11	ISO-261x

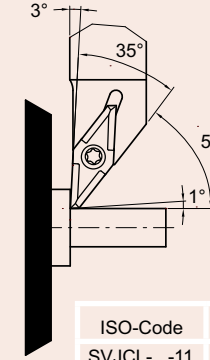

ISO-Code	Art. N°
SVJCL-...-11	ISO-263x

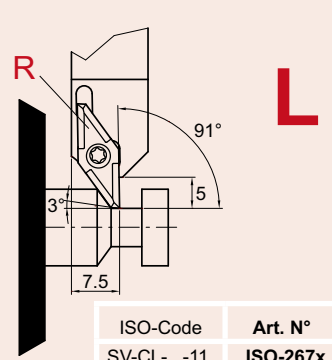

ISO-Code	Art. N°
SV-CL-...-11	ISO-267x

Plaquettes en métal dur
VHM-Wendeplatten
Solid carbide inserts

R	ISO-Code	Art. N°	revêtu / beschichtet / coated				non revêtu / unbeschichtet / uncoated	
			PVD				K10	K20
			TiN	TiAlN	HTA	HTiN		
VC GT FN-K18°								
0.05	VC GT-1103005-FN-K18	ISO-1680	■	■			■	
0.1	VC GT-110301-FN-K18	ISO-1681	■	■			■	
0.2	VC GT-110302-FN-K18	ISO-1682	■	■			■	
0.4	VC GT-110304-FN-K18	ISO-1684	■	■			■	
VC GW FN-0°								
0.05	VC GW-1103005-FN-0	ISO-1670	■	■			■	
0.1	VC GW-110301-FN-0	ISO-1671	■	■			■	
0.2	VC GW-110302-FN-0	ISO-1672	■	■			■	
0.4	VC GW-110304-FN-0	ISO-1674	■	■			■	
VC GT FN-X8°								
0.05	VC GT-1103005-FN-X8	ISO-1630	■	■	■		■	■
0.1	VC GT-110301-FN-X8	ISO-1631	■	■	■		■	■
0.2	VC GT-110302-FN-X8	ISO-1632	■	■	■		■	■
0.4	VC GT-110304-FN-X8	ISO-1634	■	■	■		■	■
VC GT ENP-X8°								
0.05	VC GT-1604005-FN-X8	ISO-1730	■	■	■		■	■
0.1	VC GT-160401-FN-X8	ISO-1731	■	■	■		■	■
0.2	VC GT-160402-FN-X8	ISO-1732	■	■	■		■	■
0.4	VC GT-160404-FN-X8	ISO-1734	■	■	■		■	■
VC GT ENP-X8°								
0.05	VC GT-1103005-ENP-X8	ISO-1630-P	□	■				□
0.1	VC GT-110301-ENP-X8	ISO-1631-P	□	■				□
0.2	VC GT-110302-ENP-X8	ISO-1632-P	□	■				□
0.4	VC GT-110304-ENP-X8	ISO-1634-P	□	■				□
VC GT FN-X17°								
0.05	VC GT-1103005-FN-X17	ISO-1640	■	■	■		■	■
0.1	VC GT-110301-FN-X17	ISO-1641	■	■	■		■	■
0.2	VC GT-110302-FN-X17	ISO-1642	■	■	■		■	■
0.4	VC GT-110304-FN-X17	ISO-1644	■	■	■		■	■
VC GT ENP-X17°								
0.05	VC GT-1604005-FN-X17	ISO-1740	■	■	■		■	■
0.1	VC GT-160401-FN-X17	ISO-1741	■	■	■		■	■
0.2	VC GT-160402-FN-X17	ISO-1742	■	■	■		■	■
0.4	VC GT-160404-FN-X17	ISO-1744	■	■	■		■	■
0.8	VC GT-160408-FN-X17	ISO-1748	■	■	■		■	■
VC GT ENP-X17°								
0.05	VC GT-1103005-ENP-X17	ISO-1640-P	□	■				□
0.1	VC GT-110301-ENP-X17	ISO-1641-P	□	■				□
0.2	VC GT-110302-ENP-X17	ISO-1642-P	□	■				□
0.4	VC GT-110304-ENP-X17	ISO-1644-P	□	■				□
VC MT EN-XF								
0.2	VC MT-110302-EN-XF	ISO-1612	■	■			■	
0.4	VC MT-110304-EN-XF	ISO-1614	■	■			■	
VC MT EN-MF								
0.4	VC MT-160404-EN-XF	ISO-1714	■	■			■	
0.8	VC MT-160408-EN-XF	ISO-1718	■	■			■	
VC MT EN-HF								
0.4	VC MT-110304-EN-HF	ISO-1694					■	
0.8	VC MT-110308-EN-HF	ISO-1698					■	
VC MT EN-HF								
0.4	VC MT-160404-EN-HF	ISO-1794					■	
0.8	VC MT-160408-EN-HF	ISO-1798					■	

Plaquettes en métal dur
VHM-Wendeplatten
Solid carbide inserts

R	ISO-Code	Art. N°	revêtu / beschichtet / coated				non revêtu / unbeschichtet / uncoated	
			PVD			CVD	K10	K20
			TiN	TiAlN	HTA			
VC GT FN-X25°								
0.05	VC GT-1103005-FN-X25	ISO-1650	■	■	■			■
0.1	VC GT-110301-FN-X25	ISO-1651	■	■	■			■
0.2	VC GT-110302-FN-X25	ISO-1652	■	■	■			■
0.4	VC GT-110304-FN-X25	ISO-1654	■	■	■			■
VC GT ENP-X25°								
0.05	VC GT-1604005-FN-X25	ISO-1750	■	■	■			■
0.1	VC GT-160401-FN-X25	ISO-1751	■	■	■			■
0.2	VC GT-160402-FN-X25	ISO-1752	■	■	■			■
0.4	VC GT-160404-FN-X25	ISO-1754	■	■	■			■
0.8	VC GT-160408-FN-X25	ISO-1758	■	■	■			■
VC MT EN-XF								
0.2	VC MT-110302-EN-XF	ISO-1612	■	■			■	
0.4	VC MT-110304-EN-XF	ISO-1614	■	■			■	
VC MT EN-MF								
0.4	VC MT-160404-EN-XF	ISO-1714	■	■			■	
0.8	VC MT-160408-EN-XF	ISO-1718	■	■			■	
VC MT EN-HF								
0.4	VC MT-110304-EN-HF	ISO-1694					■	
0.8	VC MT-110308-EN-HF	ISO-1698					■	
VC MT EN-HF								
0.4	VC MT-160404-EN-HF	ISO-1794					■	
0.8	VC MT-160408-EN-HF	ISO-1798					■	





■ = Disponible / Verfügar / Available
□ = Avec délai de livraison / Mit Lieferfrist / Available with delivery time

ECO-LINE

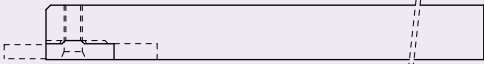
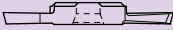

INFO

ECO-LINE

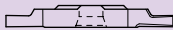
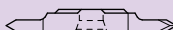
INDEX	page Seite page	
	L	R
	4.02	4.03
 	4.04	4.05
 	4.06	4.07
 	4.08	4.09

Paramètres de coupe indicatifs Empfohlene Schnittwerte Standard machining data

Matière Werkstoff Material	Tournage Drehen Turning		Tronçonnage Abstechen Cut off		Indications pour premiers réglages Hinweise für die erste Einrichtung Indications for first setting	
	Vc (m/min)	F (mm/U)	Vc (m/min)	F (mm/U)	ébauche schruppen roughing	finition schlichten finishing
Acier de décolletage Automatenstahl Free-cutting steel	120 - 200	0.01 - 0.20	80 - 150	0.01 - 0.15	vitesse de coupe moyenne avance élevée	vitesse de coupe élevée avance faible
Acier Stahl Steel	< 600 N/mm ²	80 - 160	0.01 - 0.18	70 - 120		
Acier Stahl Steel	< 800 N/mm ²	60 - 120	0.01 - 0.15	60 - 100	hoher Vorschub	niedriger Vorschub
Acier Stahl Steel	> 800 N/mm ²	50 - 100	0.01 - 0.12	40 - 80	average cutting speed	high cutting speed
Acier inoxydable Rostfreistahl Stainless steel	60 - 120	0.01 - 0.15	60 - 100	0.01 - 0.08	high cutting feed	low cutting feed
Aluminium	180 - 800	0.01 - 0.30	150 - 300	0.01 - 0.20		
Titane Titan Titanium	30 - 70	0.01 - 0.12	30 - 50	0.01 - 0.06		
Cuivre, laiton, bronze Kupfer, Messing, Bronze Copper, brass, bronze	100 - 500	0.01 - 0.30	100 - 300	0.01 - 0.20		

porte-outils
Halter
holders

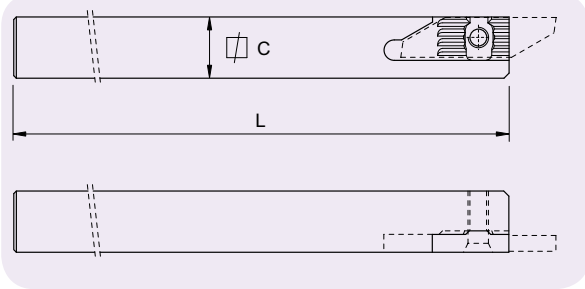

C	L	Art. N°
8 x 8	115	250-8
10 x 10	115	250-10
12 x 12	130	250-12
12 x 12	90	250-12-90
13 x 13	130	250-13
16 x 16	130	250-16
16 x 16	75	250-16-75
20 x 20	120	250-20

new

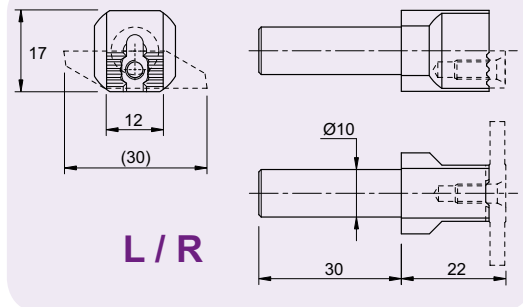
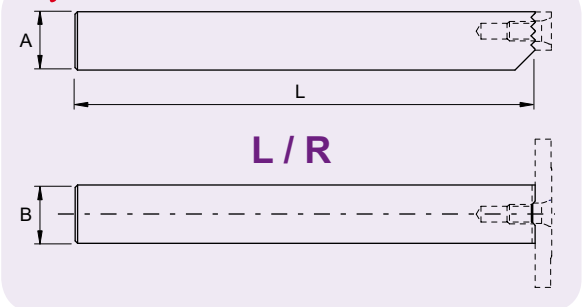

A x B	L	L/R	Art. N°
10 x 12	120	L/R	250-260F-1012
12 x 12	120	L/R	250-260F-1212

Art. N°
260 / 250-D10

Vis et clés de rechange
Ersatzschrauben und Schlüssel
Spare screws and keys

porte-outils
Halter
holders

250-... / 260-...
250-8 / 260-8
250RC / 260-C

vis
Schrauben
screw

V-M4x9-T15
V-M3.5x7-T15
V-M4x7.3-T15

clé
Schlüssel
key

C-T15

plaquette ébauche
VHM-Rohling
blank insert

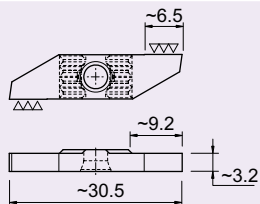

	Art. N°
sans revêtement unbeschichtet uncoated	251-E-N
revêtu beschichtet coated	251-E-AP202

AP202

revêtement PVD universel haute performance (TIALN)
universelle Hochleistung PVD Beschichtung (TIALN)
universal high performance PVD coating (TIALN)

porte-outils
Halter
holders

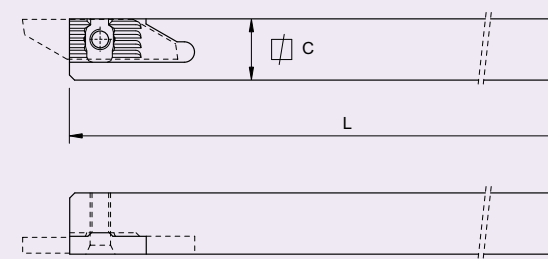

C	L	Art. N°
8 x 8	115	260-8
10 x 10	115	260-10
12 x 12	130	260-12
12 x 12	90	260-12-90
13 x 13	130	260-13
16 x 16	130	260-16
16 x 16	75	260-16-75
20 x 20	120	260-20

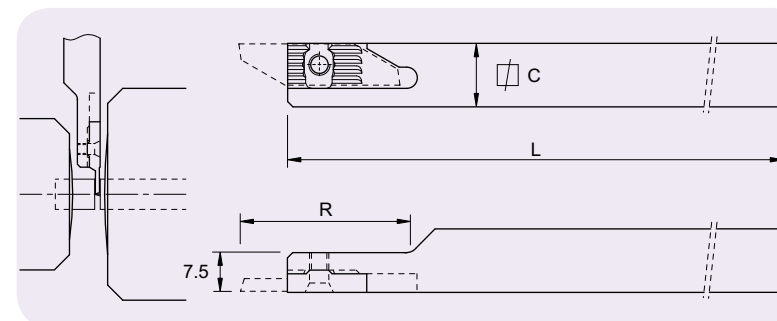

C	L	R	Art. N°
12 x 12	130	30	260-C-12

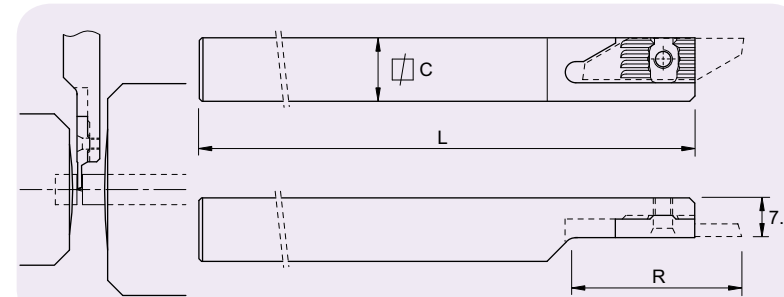

C	L	R	Art. N°
12 x 12	130	30	250RC-12
16 x 16	130	40	250RC-16

utiliser des plaquettes type 251R
WSP Typ 251R verwenden
use inserts type 251R

plaquette ébauche
VHM-Rohling
blank insert

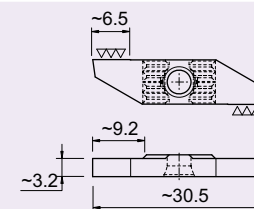

	Art. N°
sans revêtement unbeschichtet uncoated	261-E-N
revêtu beschichtet coated	261-E-AP202

AP202

revêtement PVD universel haute performance (TIALN)
universelle Hochleistung PVD Beschichtung (TIALN)
universal high performance PVD coating (TIALN)

Tronçonnage
Abstechen
Cut off

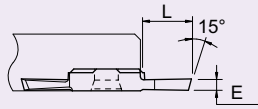

E	L	Art. N°
0.8	4	251-0.8-AP202
1.0	5	251-1.0-AP202
1.2	5	251-1.2-AP202
1.5	7	251-1.5-AP202
2.0	8.5	251-2.0-AP202
2.5	8.5	251-2.5-AP202

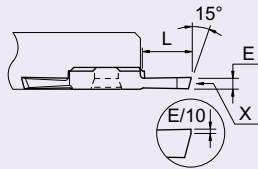

E	L	Art. N°
1.5	7	251xf-1.5-AP202
2.0	8.5	251xf-2.0-AP202

coupe à gauche déportée
versetztes Linksschneiden
left cut off line

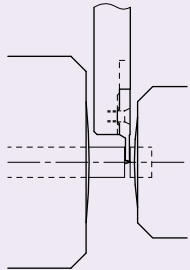

Utiliser des porte-outils série 260
Halter Serie 260 verwenden
Use 260 series holders

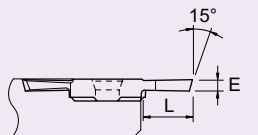

E	L	Art. N°
2.0	8.5	261L-2.0-AP202

AP202

revêtement PVD universel haute performance (TIALN)
universelle Hochleistung PVD Beschichtung (TIALN)
universal high performance PVD coating (TIALN)

Tronçonnage
Abstechen
Cut off

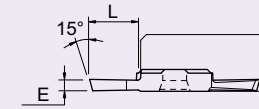

E	L	Art. N°
0.8	4	261-0.8-AP202
1.0	5	261-1.0-AP202
1.2	5	261-1.2-AP202
1.5	7	261-1.5-AP202
2.0	8.5	261-2.0-AP202
2.5	8.5	261-2.5-AP202

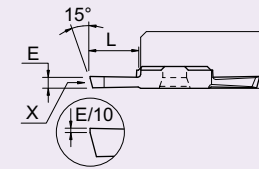

E	L	Art. N°
1.5	7	261xf-1.5-AP202
2.0	8.5	261xf-2.0-AP202

coupe à droite déportée
versetztes Rechtsschneiden
right cut off line

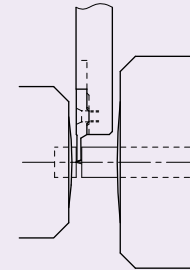

Utiliser des porte-outils série 250
Halter Serie 250 verwenden
Use 250 series holders

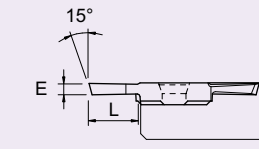

E	L	Art. N°
1.0	5	251R-1.0-AP202
1.5	7	251R-1.5-AP202
2.0	8.5	251R-2.0-AP202

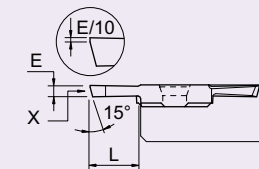

E	L	Art. N°
1.5	7	251Rxf-1.5-AP202
2.0	8.5	251Rxf-2.0-AP202

AP202

revêtement PVD universel haute performance (TIALN)
universelle Hochleistung PVD Beschichtung (TIALN)
universal high performance PVD coating (TIALN)

tourneur avant
vorwärts drehen
front turning

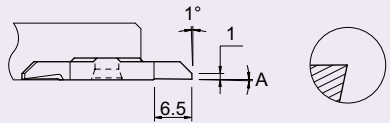

A	Art. N°
0°	252-AP202
2°	252-2°-AP202

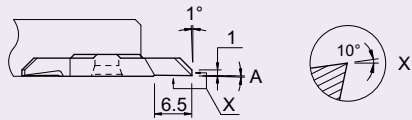

A	Art. N°
0°	252x-AP202
2°	252x-2°-AP202

tourneur arrière
rückwärts drehen
back turning

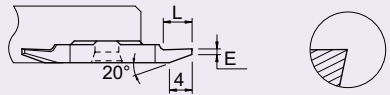

E	L	Art. N°
0.5	4	253-0.5-AP202
1.0	5	253-1.0-AP202

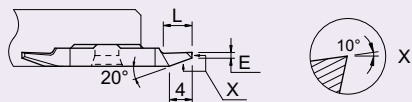

E	L	Art. N°
1.0	5	253x-1.0-AP202

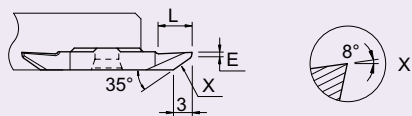

E	L	Art. N°
1.0	6	253vx-8°-AP202

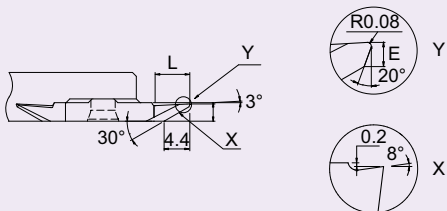

E	L	Art. N°
0.5	6	253vx-805-R08-AP202

AP202

revêtement PVD universel haute performance (TIALN)
universelle Hochleistung PVD Beschichtung (TIALN)
universal high performance PVD coating (TIALN)

tourneur avant
vorwärts drehen
front turning

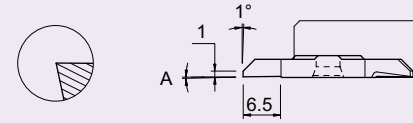

A	Art. N°
0°	262-AP202
2°	262-2°-AP202

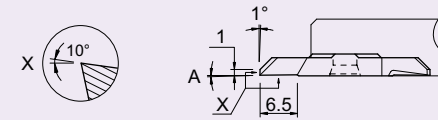

A	Art. N°
0°	262x-AP202
2°	262x-2°-AP202

tourneur arrière
rückwärts drehen
back turning

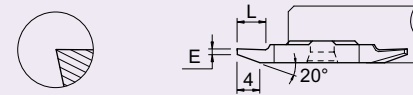

E	L	Art. N°
0.5	4	263-0.5-AP202
1.0	5	263-1.0-AP202

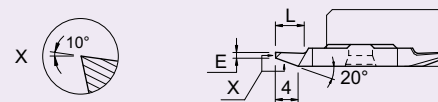

E	L	Art. N°
1.0	5	263x-1.0-AP202

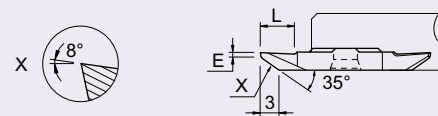

E	L	Art. N°
1.0	6	263vx-8°-AP202

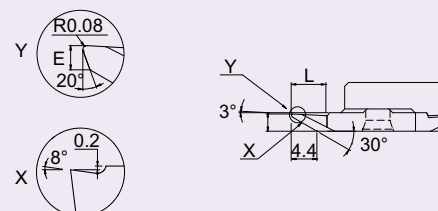

E	L	Art. N°
0.5	6	263vx-805-R08-AP202

AP202

revêtement PVD universel haute performance (TIALN)
universelle Hochleistung PVD Beschichtung (TIALN)
universal high performance PVD coating (TIALN)

foncer-tourner
einstechen und drehen
grooving and turning



E	L	L2	Art. N°
0.8	2	4	254-0.8-AP202
1.0	2.5	4	254-1.0-AP202
1.2	3	4	254-1.2-AP202
1.5	3	4	254-1.5-AP202
2.0	4	6.5	254-2.0-AP202
2.5	6	6.5	254-2.5-AP202
3.0	6.5	6.5	254-3.0-AP202

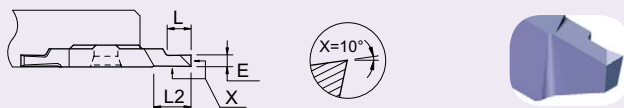

E	L	L2	Art. N°
1.0	2.5	4	254x-1.0-AP202
1.2	3	4	254x-1.2-AP202
1.5	3	4	254x-1.5-AP202
2.0	4	6.5	254x-2.0-AP202
2.5	6	6.5	254x-2.5-AP202
3.0	6.5	6.5	254x-3.0-AP202

fileter
Gewinde drehen
threading

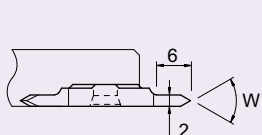

W	Art. N°
60°	256-60-2-AP202

AP202

revêtement PVD universel haute performance (TIALN)
universelle Hochleistung PVD Beschichtung (TIALN)
universal high performance PVD coating (TIALN)

foncer-tourner
einstechen und drehen
grooving and turning

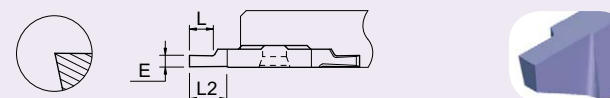

E	L	L2	Art. N°
0.8	2	4	264-0.8-AP202
1.0	2.5	4	264-1.0-AP202
1.2	3	4	264-1.2-AP202
1.5	3	4	264-1.5-AP202
2.0	4	6.5	264-2.0-AP202
2.5	6	6.5	264-2.5-AP202
3.0	6.5	6.5	264-3.0-AP202

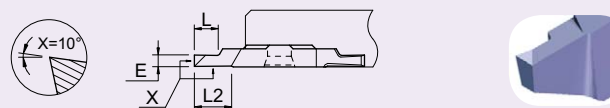

E	L	L2	Art. N°
1.0	2.5	4	264x-1.0-AP202
1.2	3	4	264x-1.2-AP202
1.5	3	4	264x-1.5-AP202
2.0	4	6.5	264x-2.0-AP202
2.5	6	6.5	264x-2.5-AP202
3.0	6.5	6.5	264x-3.0-AP202

fileter
Gewinde drehen
threading

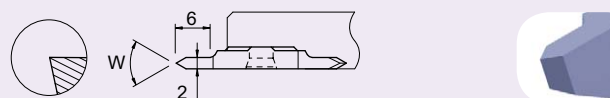

W	Art. N°
60°	266-60-2-AP202

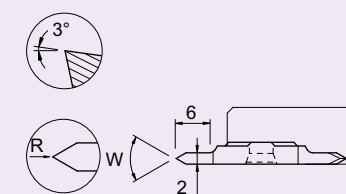

Pas Steigung Pitch	R	W	Art. N°
0.50-1.50	0.06	60°	266-AG60-AP202



AP202

revêtement PVD universel haute performance (TIALN)
universelle Hochleistung PVD Beschichtung (TIALN)
universal high performance PVD coating (TIALN)

CIRCO-LINE

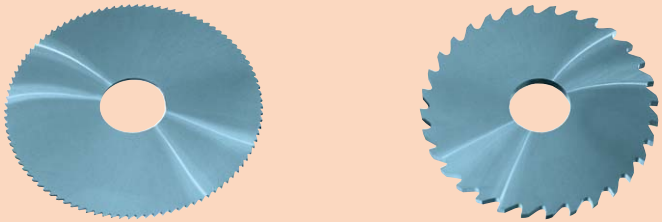

page
Seite
page

DATA	Paramètres de coupe indicatifs Empfohlene Schnittwerte Standard machining data	5.02
INFO	Définition du nombre de dents Empfohlene Zähnezah! Recommended number of teeth	5.03
		5.04 - 5.07
		5.08 - 5.09

Conseils d'utilisation
Anwendungsempfehlungen
Application recommendations

Fraises circulaires en métal dur
VHM-Kreissägeblätter
Solid carbide slitting saws

matière Werkstoff material	lubrifiant* Kühlung* coolant*	Vc m / min	choix de la denture / avance Verzahnungswahl / Vorschub teeth selection / cutting feed
acier de décolletage Automatenstahl free-cutting steel	O / E	120 - 240	Pour usinage peu profond ou longueur à fendre faible. Avance par dent : 0.005 - 0.05**
acier Stahl steel < 600 N/mm2	O / E	100 - 200	
acier Stahl steel < 800 N/mm2	O / E	80 - 160	Für geringe Bearbeitungstiefen oder kurze Schlitzlängen. Vorschub pro Zahn : 0.005-0.05**
acier Stahl steel < 1000 N/mm2	O / E	60 - 120	For low machining depth or short slots. Feed per tooth : 0.005 - 0.05**
acier Stahl steel > 1000 N/mm2	O / E	40 - 80	
Type 1102			
acier inoxydable rostfreier Stahl stainless steel	O / E	50 - 100	Pour usinage profond ou grande longueur à fendre. Avance par dent : 0.01 - 0.1**
acier réfractaire warmfester Stahl heat resistant steel	O / E	25 - 60	Für grosse Bearbeitungstiefen oder grosse Schlitzlängen. Vorschub pro Zahn : 0.01-0.1**
fonte Gusseisen cast iron	A / E	60 - 120	For deep machining or long slots. Feed per tooth : 0.01 - 0.1**
Type 1103			
Aluminium Si < 12%	O / E	150 - 600	Pour usinage de pièces fragiles ou fines. Avance par dent : 0.002 - 0.02**
Aluminium Si > 12 %	O / E	80 - 300	Für die Bearbeitung von empfindlichen oder dünnwandigen Werkstücken. Vorschub pro Zahn : 0.002 - 0.02**
titane Titan titanium	O / E	30 - 60	For machining of fragile or thin workpieces. Feed per tooth : 0.002 - 0.02**
cuivre, laiton, bronze Kupfer, Messing, Bronze copper, brass, bronze	A / O / E	80 - 300	**selon la matière, l'épaisseur ainsi que la rigidité globale
thermoplastique Thermoplaste thermoplastics	A	200 - 700	**je nach Werkstoff, Dicke und Gesamtstarrheit
duroplastique Duroplaste duroplastics	A	150 - 600	**according to material, thickness and global rigidity

* O= huile de coupe /Schneidöl / cutting oil
* E = Emulsion
* A= sec (air comprimé) / Trocken (Pressluft) / Dry (air)

avec revêtement TiN / TiCN / TiAlN, augmenter les valeurs de 20%
mit TiN / TiCN / TiAlN Beschichtung, Daten um 20% erhöhen
with TiN / TiCN / TiAlN coating, increase data by 20 %

I  idéalement 2-3 dents en contact
im Idealfall 2-3 Zähne im Einsatz
ideally 2-3 teeth in contact

N

F  trop de dents = avance trop faible par dent / pas assez de place pour le copeau
trop peu de dents = risque de vibration / usure prématurée
zu viele Zähne = zu geringer Vorschub pro Zahn / zu kleiner Spanraum
zu wenig Zähne = Vibrationen / Verschleissrisiko

O

too many teeth = feed too low per tooth / not enough place for the chips
not enough teeth = vibration / risk of quick wearout

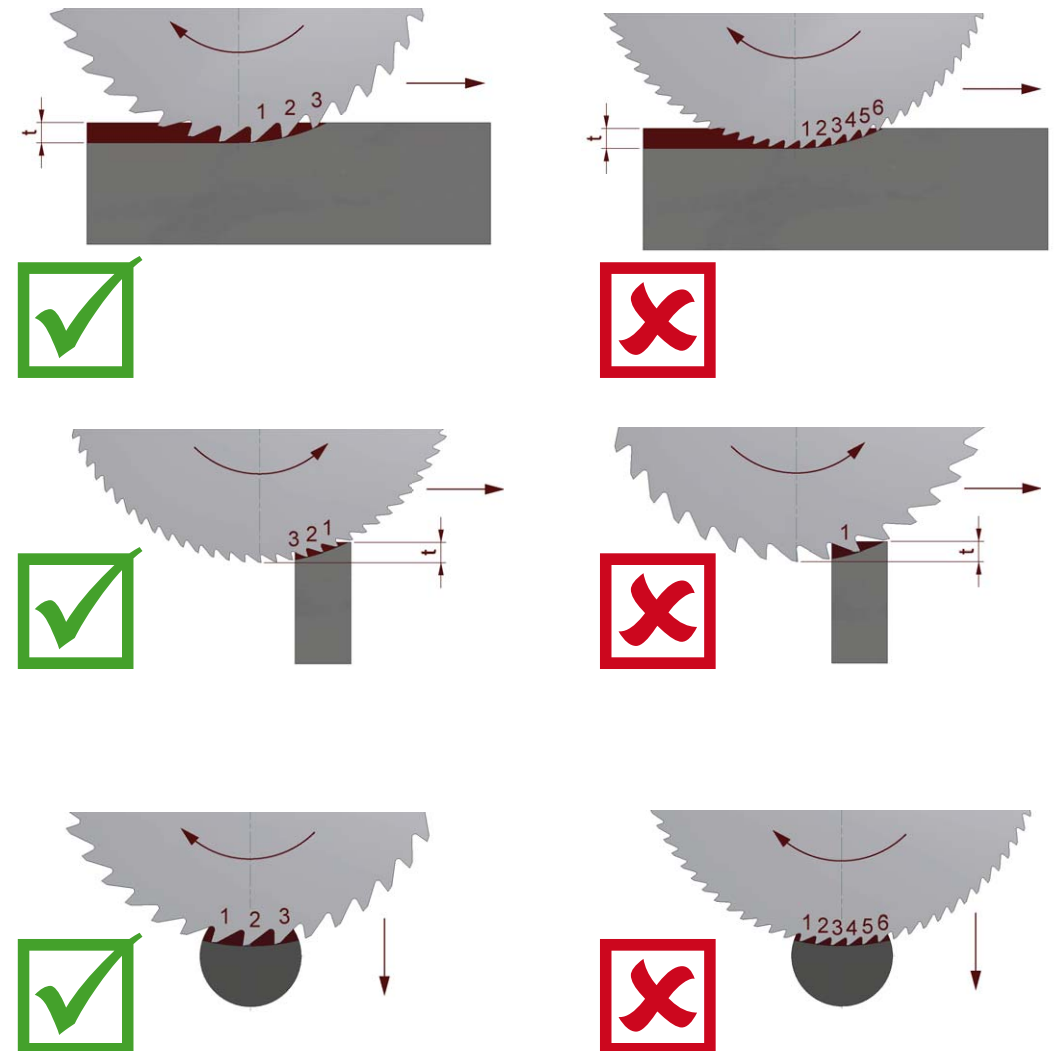

Fraises circulaires en métal dur
VHM-Kreissägeblätter
Solid carbide slitting saws

Type 1101

denture fine
feine Verzahnung
fine teeth

DIN 1837

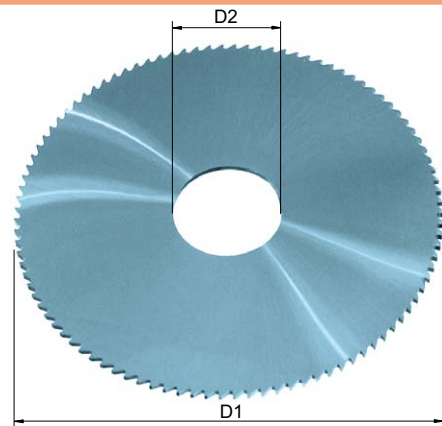

Revêtement sur demande
Beschichtung auf Anfrage
Coating on request

D1	15	20	25	30	40	50	63	80	100	125	160
D2 H7	5	5	8	8	10	13	16	22	22	22	32
épaisseur Dicke thickness +/-0.01	nombre de dents Zähnezahl number of teeth										
0.10	64	80	80	100	128						
0.15	64	80	80	100	128						
0.20	64	80	80	100	128	128	160				
0.25	64	64	80	100	100	128	128	160			
0.30	64	64	80	80	100	128	128	160			
0.35	64	64	64	80	100	100	128	160			
0.40	64	64	64	80	100	100	128	160			
0.45	48	48	64	80	80	100	128	128			
0.50	48	48	64	80	80	100	128	128	160		
0.60	48	48	64	64	80	100	100	128	160	160	
0.70	48	48	48	64	80	80	100	128	128	160	
0.80	40	40	48	64	80	80	100	128	128	160	
0.90	40	40	48	64	64	80	100	100	128	160	
1.00	40	40	48	64	64	80	100	100	128	160	160
1.10	40	40	48	48	64	80	80	100	128	128	
1.20	40	40	48	48	64	80	80	100	128	128	160
1.30	40	40	40	48	64	64	80	100	100		
1.40	40	40	40	48	64	64	80	100	100	128	
1.50	40	40	40	48	64	64	80	100	100	128	160
1.60	40	40	40	48	64	64	80	100	100	128	160
1.70	40	32	40	48	48	64	80	80	100		
1.80	40	32	40	48	48	64	80	80	100	128	128
1.90	40	32	40	48	48	64	80	80	100		
2.00	40	32	40	48	48	64	80	80	100	128	128
2.50	40	32	40	40	48	64	64	80	100	100	128
3.00	40	32	32	40	48	48	64	80	80	100	128
3.50	24	24	32	40	40	48	64	64	80	100	
4.00	24	24	32	40	40	48	64	64	80	100	100
5.00	24	24	32	32	40	48	48	64	80	100	
6.00	24	24	24	32	40	40	48	64	64	100	

Fraises circulaires en métal dur
VHM-Kreissägeblätter
Solid carbide slitting saws

Type 1102

denture grossière
grobe Verzahnung
large teeth

DIN 1838

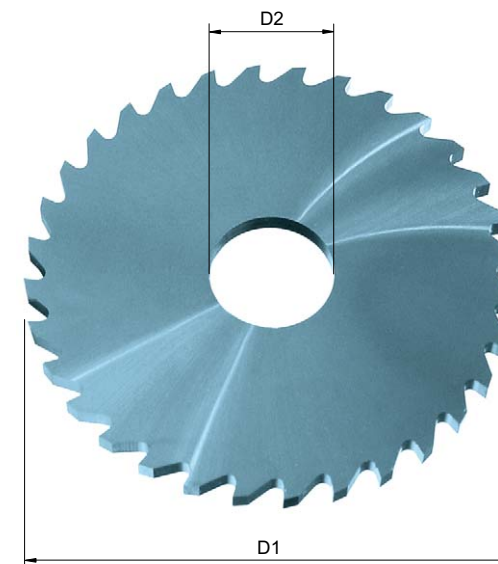

D1	15	20	25	30	40	50	63	80	100	125	160
D2 H7	5	5	8	8	10	13	16	22	22	22	32
épaisseur Dicke thickness +/-0.01	nombre de dents Zähnezahl number of teeth										
0.20	20	20	20	30	40						
0.25	20	20	20	30	40						
0.30	20	20	20	30	40						
0.40	20	20	20	30	40	48	64				
0.50	20	20	20	30	40	48	64				
0.60	20	20	20	30	40	48	48	64	80		
0.70	20	20	20	30	40	40	48	64	64		
0.80	20	20	20	24	32	40	48	64	64	80	
0.90	20	20	20	24	32	40	48	48	64	80	
1.00	20	20	20	24	32	40	48	48	64	80	80
1.20	20	20	20	24	32	40	40	48	64	64	80
1.50	20	20	20	24	32	32	40	48	48	64	80
1.60	20	20	20	24	32	32	40	48	48	64	
1.80	20	20	20	24	24	32	40	40	48	64	
2.00	20	20	20	24	24	32	40	40	48	64	80
2.50	20	20	20	24	24	32	32	40	48	48	80
3.00	20	20	20	24	24	24	32	40	40	48	64
4.00	20	20	20	24	20	24	32	32	40	48	
5.00	20	20	20	24	20	24	24	32	40	40	
6.00	20	20	20	24	20	20	24	32	32	40	

Revêtement sur demande
Beschichtung auf Anfrage
Coating on request

Fraises circulaires en métal dur
VHM-Kreissägeblätter
Solid carbide slitting saws

Type 1103

denture extra-fine
extra feine Verzahnung
extra fine teeth

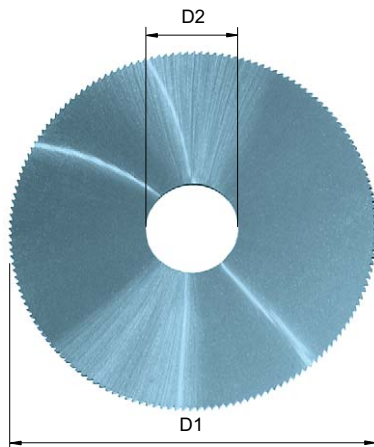

pour usinage de pièces fragiles ou fines

idéal pour le décolletage

für die Bearbeitung von empfindlichen oder dünnwandigen Werkstücken

für Langdrehautomaten besonders empfehlenswert

for machining of fragile or thin workpieces

recommended on automatic lathes

D1	8	10	12	15	20	20	20	25	25	25	30	32
D2 H7	3	3	5	5	5	5	6	5	6	8	8	8
épaisseur Dicke thickness	nombre de dents Zähnezahl number of teeth											
0.10	48	64	64	80	*	100	80	80				
0.15	48	64	64	80	*	100	80	80	100	100	*	80
0.20	48	64	64	80	*	100	80	80	100	100	*	80
0.25	48	64	64	80	80	100	80	80	100	100	*	80
0.30	48	64	64	80	80	100	80	80	100	100	100	80
0.35	48	64	64	80	80		80	80	100	100	100	80
0.40	48	64	64	80	80	100	80	80	100	100	100	80
0.50	48	64	64	80	80	100	80	80	100	100	100	80
0.60	48	64	64	80	80		80	80	100	100	100	80
0.70	48	64	64	80	80		80	80	100	100	100	80
0.80	48	64	64	80	80		80	80	100	100	100	80
0.90	48	64	64	80	80		80	80	100	100	100	80
1.00	48	64	64	80	80		80	80	100	100	100	80
1.20				80	80		80	80	100	100	100	80
1.50				80	80		80	80	100	100	100	80
2.00				80	80		80	80	100	100	100	80
2.50				80	80		80	80	100	100	100	80
3.00				80	80		80	80	100	100	100	80

*=voir type 1101
*=siehe Typ 1101
*=see type 1101

Revêtement sur demande
Beschichtung auf Anfrage
Coating on request

Fraises circulaires en métal dur
VHM-Kreissägeblätter
Solid carbide slitting saws

Type 1103

denture extra-fine
extra feine Verzahnung
extra fine teeth

D1	35	40	40	40	40	45	45	50	50	63	80
D2 H7	8	8	8	10	10	8	8	10	13	16	16
épaisseur Dicke thickness	nombre de dents Zähnezahl number of teeth										
0.15	96	100	160	100	160	100	160				
0.20	96	100	160	100	160	100	160	100			
0.25	96	100	160	*	160	100	160	100	120	120	
0.30	96	100	160	*	160	100	160	100	120	120	
0.35	96	100	160	*	160	100	160	100	120	120	
0.40	96	100	160	*	160	100	160	100	120	120	
0.50	96	100	160	100	160	100	160	100	120	120	128
0.60	96	100	160	100	160	100	160	100	120	120	128
0.70	96	100	160	100	160	100	160	100	120	120	128
0.80	96	100	160	100	160	100	160	100	120	120	128
0.90	96	100	160	100	160	100	160	100	120	120	128
1.00	96	100	160	100	160	100	160	100	120	120	128
1.20	96	100	160	100	160	100	160	100	120	120	128
1.50	96	100	160	100	160	100	160	100	120	120	128
2.00	96	100	160	100	160	100	160	100	120	120	128
2.50	96	100	160	100	160	100	160	100	120	120	128
3.00	96	100	160	100	160	100	160	100	120	120	128

Fraises circulaires spéciales en métal dur
Sonder VHM-Kreissägeblätter
Solid carbide special slitting saws

exécution spéciale sur demande
Sonderanfertigung auf Anfrage
special execution on request

- denture alternée
- wechselseitige Abkantung
- alternate teeth



- denture forme B
- B Zahnform (Bogenzahn)
- tooth form B



Tasseaux porte-fraise avec serrage avant
Fräsdorne (Spannung von vorne)
Milling arbors with front clamping

Type 2810

Tasseaux pour rotation à droite (serrage avant avec filet à droite)
Fräsdorne für Drehrichtung rechts (Spannung von vorne mit Rechtsgewinde)
Arbors for right hand rotation (front clamping with right hand thread)

R

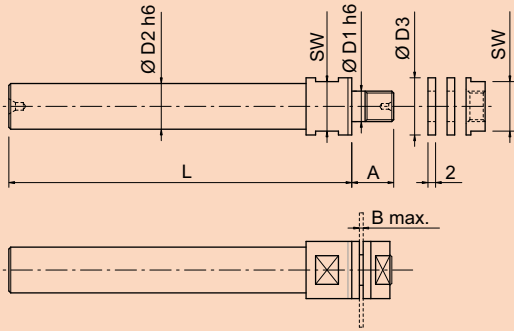

D1	D2	D3	L	A	SW	B	Art. N°
5.0	6	10	70	9	8	6	2810-5-6
5.0	10	10	80	9	8	6	2810-5-10
6.0	10	12	80	9.5	10	6	2810-6-10
8.0	10	15	80	10	13	6	2810-8-10
8.0	12	15	90	10	13	6	2810-8-12
10.0	6	18	80	10.5	15	6	2810-10-6
10.0	10	18	80	10.5	15	6	2810-10-10
10.0	16	18	100	10.5	15	6	2810-10-16
13.0	16	22	110	11	19	6	2810-13-16
16.0	10	22	80	8	19	3	2810-16-10
16.0	20	26	120	12	22	6	2810-16-20
22.0	16	32	132	13	27	6	2810-22-16

Type 2815

Tasseaux pour très petites fraises circulaires
Fräsdorne für sehr kleine Kreissägeblätter
Arbors for very small slitting saws

R

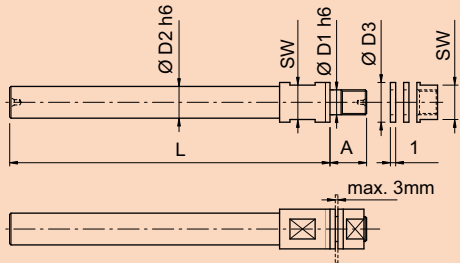

D1	D2	D3	L	A	SW	Art. N°
3.0	5	5	60	7	4	2815-3-5
5.0	6	7.5	70	7	6	2815-5-6

Tasseaux porte-fraise avec serrage arrière
Fräsdorne (Spannung von hinten)
Milling arbors with rear clamping

Type 2820

Tasseaux pour rotation à droite (serrage arrière avec filet à gauche)
Fräsdorne für Drehrichtung rechts (Spannung von hinten mit Linksgewinde)
Arbors for right hand rotation (rear clamping with left hand thread)

R

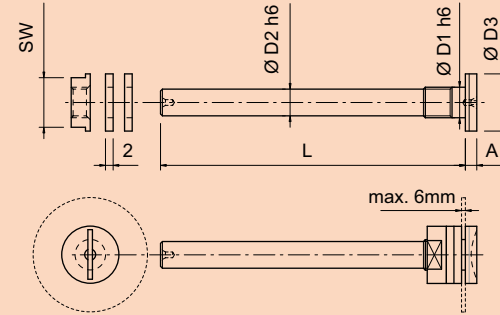

D1	D2	D3	L	A	SW	Art. N°
5.0	4	10	50	3	8	2820-5-4
6.0	5	12	60	3	10	2820-6-5
8.0	6	15	70	3	13	2820-8-6
8.0	7	15	80	3	13	2820-8-7
10.0	6	18	70	3.5	15	2820-10-6
10.0	8	18	90	3.5	15	2820-10-8
13.0	10	22	110	3.5	19	2820-13-10
16.0	12	26	120	3.5	22	2820-16-12

Type 1820

Tasseaux pour rotation à gauche (serrage arrière avec filet à droite)
Fräsdorne für Drehrichtung links (Spannung von hinten mit Rechtsgewinde)
Arbors for left hand rotation (rear clamping with right hand thread)

L

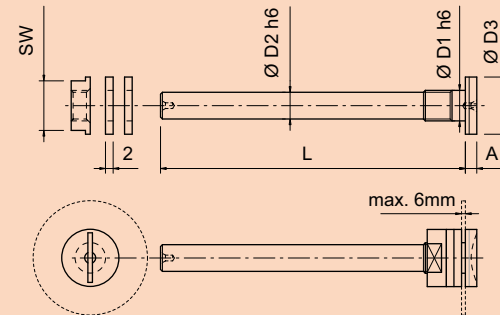

D1	D2	D3	L	A	SW	Art. N°
5.0	4	10	50	3	8	1820-5-4
6.0	5	12	60	3	10	1820-6-5
8.0	6	15	70	3	13	1820-8-6
10.0	6	18	70	3.5	15	1820-10-6

Pièces de rechange
Ersatzteile
Spare parts

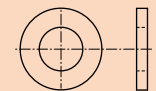

Art. N°
1820-D1*-a
2810-D1*-a
2815-D1*-a
2820-D1*-a

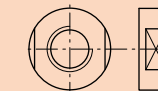

Art. N°
1820-D1*-b
2810-D1*-b
2815-D1*-b
2820-D1*-b

*Diamètre D1 à spécifier
*Durchmesser D1 angeben
*Diameter D1 to be specified



Chaque tasseau est livré avec 2 entretoises et 1 écrou
Jeder Fräsdorn wird mit 2 Abstandsrings und 1 Mutter geliefert
2 distance rings and 1 nut are included with each arbor

TOOLING-LINE



	page Seite page		page Seite page
INFO	6.02 6.03		6.24
	6.04 -		6.25
	6.07		
	6.08 -		6.26
	6.15		
	6.16 -		-
	6.17		
	6.18		6.30
	6.19 -		6.30
	6.21		
	6.22 6.23		6.31
		TORNOS DECO 	6.31



Paramètres de coupe indicatifs
Empfohlene Schnittwerte
Standard machining data

matière Werkstoff material	lubrifiant* Kühlung* coolant*								
		Forets en métal dur VHM-Bohrer Solid carbide drills				Alésoirs en métal dur VHM-Reibahlen Solid carbide reamers			
		Vc	avance par tour Vorschub per Umdrehung Feed per rotation mm / \curvearrowright			Vc	avance par tour Vorschub per Umdrehung Feed per rotation mm / \curvearrowright		
m / min	Ø 1-4	Ø 4-8	Ø 8-12	m / min	Ø 1-4	Ø 4-8	Ø 8-12		
acier de décolletage Automatenstahl free-cutting steel	O / E	90 - 120	0.02 - 0.05	0.05 - 0.07	0.07 - 0.10	15 - 22	0.12	0.16	0.25
acier Stahl steel < 600 N/mm2	O / E	80 - 110	0.01 - 0.04	0.04 - 0.06	0.06 - 0.08	10 - 18	0.10	0.15	0.20
acier Stahl steel < 800 N/mm2	O / E	70 - 100	0.01 - 0.03	0.03 - 0.05	0.05 - 0.07	8 - 15	0.10	0.13	0.16
acier Stahl steel < 1000 N/mm2	O / E	60 - 80	0.01 - 0.03	0.03 - 0.05	0.05 - 0.07	6 - 12	0.07	0.10	0.13
acier Stahl steel > 1000 N/mm2	O / E	30 - 50	0.01 - 0.02	0.02 - 0.04	0.04 - 0.06	5 - 10	0.05	0.08	0.10
acier inoxydable rostfreier Stahl stainless steel	O / E	30 - 50	0.01 - 0.03	0.03 - 0.05	0.05 - 0.08	8 - 12	0.04	0.06	0.08
acier réfractaire warmfester Stahl heat resistant steel	O / E	20 - 40	0.01 - 0.02	0.02 - 0.03	0.03 - 0.05	5 - 10	0.03	0.05	0.07
fonte Gusseisen cast iron	A / E	70 - 100	0.03 - 0.05	0.05 - 0.07	0.07 - 0.10	8 - 12	0.20	0.25	0.30
Aluminium Si < 12%	O / E	100 - 150	0.04 - 0.06	0.06 - 0.10	0.10 - 0.14	20 - 35	0.20	0.25	0.30
Aluminium Si > 12 %	O / E	50 - 100	0.02 - 0.04	0.04 - 0.06	0.06 - 0.09	10 - 22	0.10	0.15	0.20
titane Titan titanium	O / E	30 - 50	0.01 - 0.02	0.02 - 0.04	0.04 - 0.08	6 - 10	0.08	0.10	0.12
cuivre, laiton, bronze Kupfer, Messing, Bronze copper, brass, bronze	A / O / E	60 - 100	0.03 - 0.06	0.06 - 0.10	0.10 - 0.15	15 - 40	0.15	0.20	0.30
thermoplastique Thermoplaste thermoplastics	A	80 - 150	0.03 - 0.04	0.04 - 0.06	0.06 - 0.08	15 - 35	0.10	0.15	0.20
duroplastique Duroplaste duroplastics	A	60 - 120	0.03 - 0.05	0.05 - 0.08	0.08 - 0.12	15 - 35	0.10	0.15	0.20

* O = huile de coupe / Schneidöl / cutting oil
* E = Emulsion
* A = sec (air comprimé) / Trocken (Pressluft) / Dry (air)

avec revêtement TiN / TiCN / TiAlN, augmenter les valeurs de 20%
mit TiN / TiCN / TiAlN Beschichtung, Daten um 20% erhöhen
with TiN / TiCN / TiAlN coating, increase data by 20 %

Paramètres de coupe indicatifs
Empfohlene Schnittwerte
Standard machining data

matière Werkstoff material	lubrifiant* Kühlung* coolant*							
		Micro-fraises de précision en métal dur Vollhartmetall Micropräzisionsfräser Solid carbide precision micro end mills			Fraises en bout en métal dur VHM-Schaftfräser Solid carbide end mills			
		Vc	avance par dent Vorschub pro Zahn Feed per tooth mm / Z		Vc	avance par dent Vorschub pro Zahn Feed per tooth mm / Z		
m / min	Ø 0.2-1.2	Ø 1.3-2.9	m / min	Ø 3-4	Ø 4-8	Ø 8-12		
acier de décolletage Automatenstahl free-cutting steel	O / E	30 - 100	0.002 - 0.010	0.005 - 0.020	100 - 150	0.015 - 0.04	0.02 - 0.05	0.04 - 0.08
acier Stahl steel < 600 N/mm2	O / E	30 - 90	0.002 - 0.008	0.005 - 0.015	80 - 120	0.01 - 0.03	0.02 - 0.04	0.03 - 0.07
acier Stahl steel < 800 N/mm2	O / E	30 - 80	0.001 - 0.008	0.005 - 0.015	70 - 100	0.01 - 0.02	0.015 - 0.03	0.02 - 0.05
acier Stahl steel < 1000 N/mm2	O / E	30 - 60	0.001 - 0.008	0.003 - 0.012	50 - 80	0.01 - 0.02	0.015 - 0.03	0.02 - 0.05
acier Stahl steel > 1000 N/mm2	O / E	25 - 60	0.001 - 0.005	0.002 - 0.012	30 - 60	0.01 - 0.02	0.015 - 0.03	0.02 - 0.05
acier inoxydable rostfreier Stahl stainless steel	O / E	30 - 70	0.001 - 0.008	0.004 - 0.020	40 - 80	0.01 - 0.03	0.01 - 0.04	0.02 - 0.05
acier réfractaire warmfester Stahl heat resistant steel	O / E	20 - 50	0.001 - 0.005	0.002 - 0.012	20 - 50	0.01 - 0.03	0.01 - 0.04	0.02 - 0.05
fonte Gusseisen cast iron	A / E	30 - 100	0.002 - 0.010	0.004 - 0.020	60 - 100	0.01 - 0.03	0.012 - 0.04	0.03 - 0.06
Aluminium Si < 12%	O / E	100 - 300	0.002 - 0.010	0.005 - 0.020	250 - 400	0.02 - 0.05	0.02 - 0.06	0.03 - 0.10
Aluminium Si > 12 %	O / E	80 - 250	0.002 - 0.008	0.005 - 0.018	120 - 250	0.015 - 0.04	0.02 - 0.05	0.03 - 0.08
titane Titan titanium	O / E	25 - 40	0.001 - 0.008	0.003 - 0.010	25 - 50	0.01 - 0.03	0.02 - 0.04	0.03 - 0.05
cuivre, laiton, bronze Kupfer, Messing, Bronze copper, brass, bronze	A / O / E	60 - 200	0.002 - 0.010	0.004 - 0.020	100 - 300	0.015 - 0.04	0.03 - 0.06	0.03 - 0.08
thermoplastique Thermoplaste thermoplastics	A	80 - 250	0.003 - 0.012	0.008 - 0.025	120 - 200	0.02 - 0.05	0.03 - 0.07	0.04 - 0.10
duroplastique Duroplaste duroplastics	A	60 - 180	0.003 - 0.012	0.008 - 0.025	80 - 120	0.02 - 0.05	0.03 - 0.07	0.04 - 0.10

* O = huile de coupe / Schneidöl / cutting oil
* E = Emulsion
* A = sec (air comprimé) / Trocken (Pressluft) / Dry (air)

avec revêtement TiN / TiCN / TiAlN, augmenter les valeurs de 20%
mit TiN / TiCN / TiAlN Beschichtung, Daten um 20% erhöhen
with TiN / TiCN / TiAlN coating, increase data by 20 %

Forets à centrer plat
Zentrierflachbohrer
Centering flat drills

Type 1200

L



A	D	L	métal dur Vollhartmetall solid carbide	
			Art. N°	
90°	3	13	1200-313	
90°	3	17	1200-317	
90°	3	38	1200-338	
90°	4	40	1200-440	
90°	5	50	1200-550	
90°	6	50	1200-650	
90°	8	58	1200-858	
90°	10	66	1200-1066	
90°	12	73	1200-1273	

Forets à centrer hélicoïdaux
Zentrierspiralbohrer
Centering twist drills

Type 1500

L

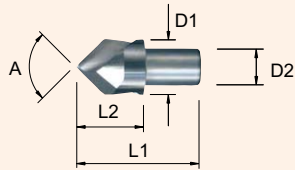

A	D1	D2	L1	L2	HSS	métal dur Vollhartmetall solid carbide
					Art. N°	Art. N°
90°	5	4	17	8	1500-5-HSS	1500-5-MD
90°	7	5	17	8	1500-7-HSS	1500-7-MD
90°	10	6	22	10	1500-10-HSS	1500-10-MD
90°	12	8	26	12	1500-12-HSS	1500-12-MD

Type 1510

L

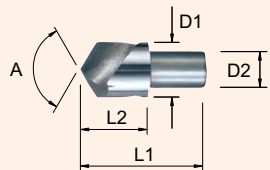

120°	5	4	17	8	1510-5-HSS	1510-5-MD
120°	7	5	17	8	1510-7-HSS	1510-7-MD
120°	10	6	22	10	1510-10-HSS	1510-10-MD
120°	12	8	26	12	1510-12-HSS	1510-12-MD

Revêtement sur demande
Beschichtung auf Anfrage
Coating on request

Forets à centrer plat
Zentrierflachbohrer
Centering flat drills

Type 2200

R



A	D	L	métal dur Vollhartmetall solid carbide	
			Art. N°	
90°	3	13	2200-313	
90°	3	17	2200-317	
90°	3	38	2200-338	
90°	4	40	2200-440	
90°	5	50	2200-550	
90°	6	50	2200-650	
90°	8	58	2200-858	
90°	10	66	2200-1066	
90°	12	73	2200-1273	

Forets à centrer hélicoïdaux
Zentrierspiralbohrer
Centering twist drills

Type 2520

R

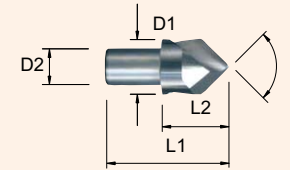

A	D1	D2	L1	L2	HSS	métal dur Vollhartmetall solid carbide
					Art. N°	Art. N°
90°	5	4	17	8	2520-5-HSS	2520-5-MD
90°	7	5	17	8	2520-7-HSS	2520-7-MD
90°	10	6	22	10	2520-10-HSS	2520-10-MD
90°	12	8	26	12	2520-12-HSS	2520-12-MD

Type 2530

R

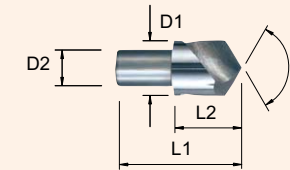

120°	5	4	17	8	2530-5-HSS	2530-5-MD
120°	7	5	17	8	2530-7-HSS	2530-7-MD
120°	10	6	22	10	2530-10-HSS	2530-10-MD
120°	12	8	26	12	2530-12-HSS	2530-12-MD

Revêtement sur demande
Beschichtung auf Anfrage
Coating on request

Forets à centrer NC
NC-Zentrierbohrer
NC centering tools

Type 1680 L 90°

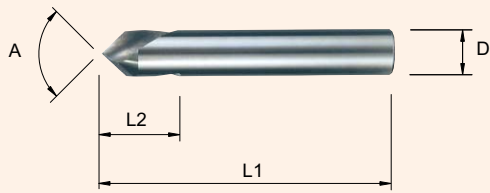

A	D	L1	L2	HSS		métal dur Vollhartmetall solid carbide	
				Art. N°	Art. N°		
90°	2	38	8	---	---	1680-2-90-MD	1680-2-90-MD
90°	2.5	38	8	---	---	1680-2.5-90-MD	1680-2.5-90-MD
90°	3	38	10	1680-3-90-HSS	1680-3-90-MD	1680-3-90-MD	1680-3-90-MD
90°	4	50	12	1680-4-90-HSS	1680-4-90-MD	1680-4-90-MD	1680-4-90-MD
90°	5	50	15	1680-5-90-HSS	1680-5-90-MD	1680-5-90-MD	1680-5-90-MD
90°	6	57	16	1680-6-90-HSS	1680-6-90-MD	1680-6-90-MD	1680-6-90-MD
90°	8	63	20	1680-8-90-HSS	1680-8-90-MD	1680-8-90-MD	1680-8-90-MD
90°	10	72	22	1680-10-90-HSS	1680-10-90-MD	1680-10-90-MD	1680-10-90-MD
90°	12	73	24	1680-12-90-HSS	1680-12-90-MD	1680-12-90-MD	1680-12-90-MD
90°	16	82	26	---	---	1680-16-90-MD	1680-16-90-MD
90°	20	92	30	---	---	1680-20-90-MD	1680-20-90-MD

Type 1680 L 120°

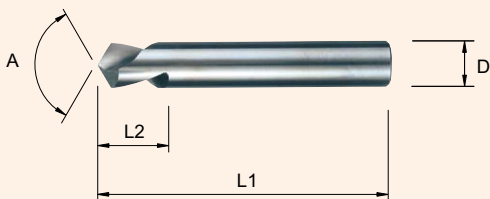

A	D	L1	L2	HSS		métal dur Vollhartmetall solid carbide	
				Art. N°	Art. N°		
120°	2	38	8	---	---	1680-2-120-MD	1680-2-120-MD
120°	2.5	38	8	---	---	1680-2.5-120-MD	1680-2.5-120-MD
120°	3	38	10	1680-3-120-HSS	1680-3-120-MD	1680-3-120-MD	1680-3-120-MD
120°	4	50	12	1680-4-120-HSS	1680-4-120-MD	1680-4-120-MD	1680-4-120-MD
120°	5	50	15	1680-5-120-HSS	1680-5-120-MD	1680-5-120-MD	1680-5-120-MD
120°	6	57	16	1680-6-120-HSS	1680-6-120-MD	1680-6-120-MD	1680-6-120-MD
120°	8	63	20	1680-8-120-HSS	1680-8-120-MD	1680-8-120-MD	1680-8-120-MD
120°	10	72	22	1680-10-120-HSS	1680-10-120-MD	1680-10-120-MD	1680-10-120-MD
120°	12	73	24	1680-12-120-HSS	1680-12-120-MD	1680-12-120-MD	1680-12-120-MD
120°	16	82	26	---	---	1680-16-120-MD	1680-16-120-MD
120°	20	92	30	---	---	1680-20-120-MD	1680-20-120-MD

Revêtement sur demande
Beschichtung auf Anfrage
Coating on request

Forets à centrer NC
NC-Zentrierbohrer
NC centering tools

Type 2680 R 90°

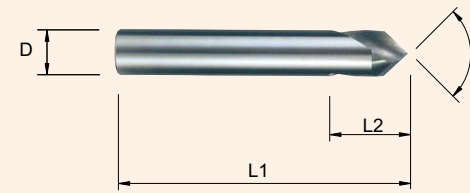

A	D	L1	L2	HSS		métal dur Vollhartmetall solid carbide	
				Art. N°	Art. N°		
90°	2	38	8	---	---	2680-2-90-MD	2680-2-90-MD
90°	2.5	38	8	---	---	2680-2.5-90-MD	2680-2.5-90-MD
90°	3	38	10	2680-3-90-HSS	2680-3-90-MD	2680-3-90-MD	2680-3-90-MD
90°	4	50	12	2680-4-90-HSS	2680-4-90-MD	2680-4-90-MD	2680-4-90-MD
90°	5	50	15	2680-5-90-HSS	2680-5-90-MD	2680-5-90-MD	2680-5-90-MD
90°	6	57	16	2680-6-90-HSS	2680-6-90-MD	2680-6-90-MD	2680-6-90-MD
90°	8	63	20	2680-8-90-HSS	2680-8-90-MD	2680-8-90-MD	2680-8-90-MD
90°	10	72	22	2680-10-90-HSS	2680-10-90-MD	2680-10-90-MD	2680-10-90-MD
90°	12	73	24	2680-12-90-HSS	2680-12-90-MD	2680-12-90-MD	2680-12-90-MD
90°	16	82	26	---	---	2680-16-90-MD	2680-16-90-MD
90°	20	92	30	---	---	2680-20-90-MD	2680-20-90-MD

Type 2680 R 120°

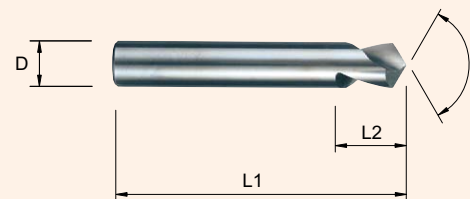

A	D	L1	L2	HSS		métal dur Vollhartmetall solid carbide	
				Art. N°	Art. N°		
120°	2	38	8	---	---	2680-2-120-MD	2680-2-120-MD
120°	2.5	38	8	---	---	2680-2.5-120-MD	2680-2.5-120-MD
120°	3	38	10	2680-3-120-HSS	2680-3-120-MD	2680-3-120-MD	2680-3-120-MD
120°	4	50	12	2680-4-120-HSS	2680-4-120-MD	2680-4-120-MD	2680-4-120-MD
120°	5	50	15	2680-5-120-HSS	2680-5-120-MD	2680-5-120-MD	2680-5-120-MD
120°	6	57	16	2680-6-120-HSS	2680-6-120-MD	2680-6-120-MD	2680-6-120-MD
120°	8	63	20	2680-8-120-HSS	2680-8-120-MD	2680-8-120-MD	2680-8-120-MD
120°	10	72	22	2680-10-120-HSS	2680-10-120-MD	2680-10-120-MD	2680-10-120-MD
120°	12	73	24	2680-12-120-HSS	2680-12-120-MD	2680-12-120-MD	2680-12-120-MD
120°	16	82	26	---	---	2680-16-120-MD	2680-16-120-MD
120°	20	92	30	---	---	2680-20-120-MD	2680-20-120-MD

Revêtement sur demande
Beschichtung auf Anfrage
Coating on request

Forets pointeurs en métal dur
Vollhartmetall Anbohrer
Solid carbide spot drills

Type 2012 R

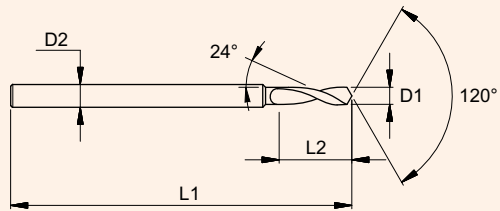

D1 h6	D2 h6	L1	L2	D1 h6	D2 h6	L1	L2
0.50	1.5	30	1.7	1.30	1.5	30	4.2
0.55	1.5	30	1.9	1.40	1.5	30	4.7
0.60	1.5	30	1.9	1.50	2.0	38	4.7
0.65	1.5	30	1.9	1.60	2.0	38	5.4
0.70	1.5	30	2.4	1.70	2.0	38	5.4
0.75	1.5	30	2.4	1.80	2.0	38	6.5
0.80	1.5	30	2.6	1.90	2.0	38	6.5
0.85	1.5	30	2.6	2.00	2.5	38	6.5
0.90	1.5	30	3.0	2.10	2.5	38	6.5
0.95	1.5	30	3.0	2.20	2.5	38	6.5
1.00	1.5	30	3.4	2.30	2.5	38	6.5
1.10	1.5	30	3.8	2.40	2.5	38	6.5
1.20	1.5	30	4.2				

Micro forets en métal dur
Vollhartmetall Mikro-Bohrer
Solid carbide micro drills

Type 2013 R

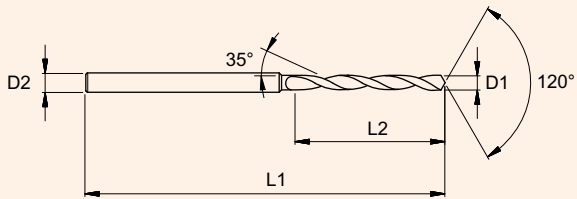

D1 h6	D2 h6	L1	L2	D1 h6	D2 h6	L1	L2
0.40	1.0	25	3.6	1.10	1.5	30	9.0
0.45	1.0	25	3.6	1.15	1.5	30	9.0
0.50	1.0	25	4.0	1.20	1.5	30	10.0
0.55	1.0	25	4.5	1.25	1.5	30	10.0
0.60	1.0	25	4.5	1.30	1.5	30	10.0
0.65	1.0	25	5.0	1.35	1.5	30	11.2
0.70	1.0	25	5.6	1.40	1.5	30	11.2
0.75	1.0	25	5.6	1.45	1.5	30	11.2
0.80	1.5	30	6.3	1.50	2.0	38	12.0
0.85	1.5	30	6.3	1.60	2.0	38	12.0
0.90	1.5	30	7.1	1.70	2.0	38	12.0
0.95	1.5	30	7.1	1.80	2.0	38	12.0
1.00	1.5	30	8.0	1.90	2.0	38	12.0
1.05	1.5	30	8.0				

Type 2014 R

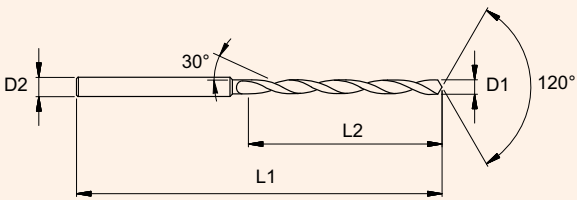

D1 h6	D2 h6	L1	L2	D1 h6	D2 h6	L1	L2
0.50	1.5	30	6.0	1.25	1.5	38	15.0
0.55	1.5	30	6.5	1.30	1.5	38	17.0
0.60	1.5	30	6.5	1.35	1.5	38	17.0
0.65	1.5	30	7.5	1.40	1.5	38	17.0
0.70	1.5	30	8.5	1.45	1.5	38	17.0
0.75	1.5	30	8.5	1.50	2.0	38	18.0
0.80	1.5	30	9.5	1.55	2.0	38	18.0
0.85	1.5	30	9.5	1.60	2.0	38	18.0
0.90	1.5	30	10.5	1.65	2.0	38	18.0
0.95	1.5	30	10.5	1.70	2.0	38	18.0
1.00	1.5	38	12.0	1.75	2.0	38	18.0
1.05	1.5	38	12.0	1.80	2.0	38	18.0
1.10	1.5	38	13.5	1.85	2.0	38	18.0
1.15	1.5	38	13.5	1.90	2.0	38	18.0
1.20	1.5	38	15.0	1.95	2.0	38	18.0

Revêtement sur demande
Beschichtung auf Anfrage
Coating on request

forets hélicoïdaux en métal dur
Vollhartmetall Spiralbohrer
Solid carbide twist drills

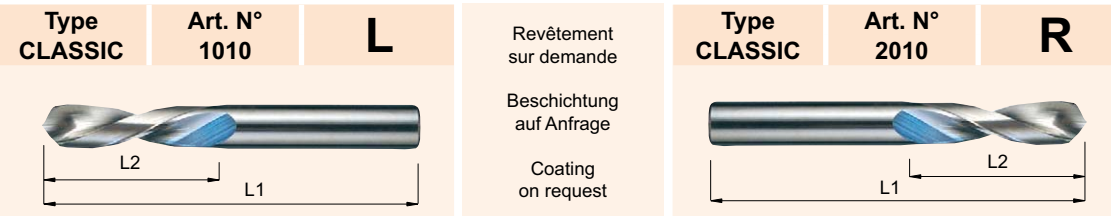

D h6	L1	L2	D h6	L1	L2	D h6	L1	L2	D h6	L1	L2
0.50	30	5	2.55	45	18	0.50	30	5	2.55	45	18
0.55	30	5	2.60	45	18	0.55	30	5	2.60	45	18
0.60	30	5	2.65	45	18	0.60	30	5	2.65	45	18
0.65	30	6	2.70	45	18	0.65	30	6	2.70	45	18
0.70	30	6	2.75	45	18	0.70	30	6	2.75	45	18
0.75	30	8	2.80	45	18	0.75	30	8	2.80	45	18
0.80	30	8	2.85	45	18	0.80	30	8	2.85	45	18
0.85	30	9	2.90	45	18	0.85	30	9	2.90	45	18
0.90	30	9	2.95	45	18	0.90	30	9	2.95	45	18
0.95	30	10	3.00	45	18	0.95	30	10	3.00	45	18
1.00	30	10	3.10	50	20	1.00	30	10	3.10	50	20
1.05	30	10	3.20	50	20	1.05	30	10	3.20	50	20
1.10	30	10	3.30	50	20	1.10	30	10	3.30	50	20
1.15	30	12	3.40	50	20	1.15	30	12	3.40	50	20
1.20	30	12	3.50	50	20	1.20	30	12	3.50	50	20
1.25	30	12	3.60	50	20	1.25	30	12	3.60	50	20
1.30	30	12	3.70	50	20	1.30	30	12	3.70	50	20
1.35	30	12	3.80	50	20	1.35	30	12	3.80	50	20
1.40	30	12	3.90	50	20	1.40	30	12	3.90	50	20
1.45	30	12	4.00	50	20	1.45	30	12	4.00	50	20
1.50	30	12	4.10	50	25	1.50	30	12	4.10	50	25
1.55	40	16	4.20	50	25	1.55	40	16	4.20	50	25
1.60	40	16	4.30	50	25	1.60	40	16	4.30	50	25
1.65	40	16	4.40	50	25	1.65	40	16	4.40	50	25
1.70	40	16	4.50	50	25	1.70	40	16	4.50	50	25
1.75	40	16	4.60	50	25	1.75	40	16	4.60	50	25
1.80	40	16	4.70	50	25	1.80	40	16	4.70	50	25
1.85	40	16	4.80	50	25	1.85	40	16	4.80	50	25
1.90	40	16	4.90	50	25	1.90	40	16	4.90	50	25
1.95	40	16	5.00	50	25	1.95	40	16	5.00	50	25
2.00	40	16	5.10	50	25	2.00	40	16	5.10	50	25
2.05	40	18	5.20	50	25	2.05	40	18	5.20	50	25
2.10	40	18	5.30	50	25	2.10	40	18	5.30	50	25
2.15	40	18	5.40	50	25	2.15	40	18	5.40	50	25
2.20	40	18	5.50	50	25	2.20	40	18	5.50	50	25
2.25	40	18	5.60	50	25	2.25	40	18	5.60	50	25
2.30	40	18	5.70	50	25	2.30	40	18	5.70	50	25
2.35	40	18	5.80	50	25	2.35	40	18	5.80	50	25
2.40	40	18	5.90	50	25	2.40	40	18	5.90	50	25
2.45	40	18	6.00	50	25	2.45	40	18	6.00	50	25
2.50	40	18				2.50	40	18			

Forets à hélice progressive en métal dur
Vollhartmetall Bohrer mit progressiver Spirale
Solid carbide twist drills with progressive spiral

Type WINNER	Art. N° 1005	L
DIN 1897		

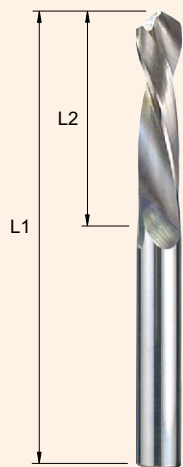

D h6	L1	L2	D h6	L1	L2
1.50	32	9	4.50	58	24
1.55	34	10	4.60	58	24
1.60	34	10	4.70	58	24
1.65	34	10	4.80	62	26
1.70	34	10	4.90	62	26
1.75	36	11	5.00	62	26
1.80	36	11	5.10	62	26
1.85	36	11	5.20	62	26
1.90	36	11	5.30	62	26
1.95	38	12	5.40	66	28
2.00	38	12	5.50	66	28
2.05	38	12	5.60	66	28
2.10	38	12	5.70	66	28
2.15	40	13	5.80	66	28
2.20	40	13	5.90	66	28
2.25	40	13	6.00	66	28
2.30	40	13	6.10	70	31
2.35	40	13	6.20	70	31
2.40	43	14	6.30	70	31
2.45	43	14	6.40	70	31
2.50	43	14	6.50	70	31
2.55	43	14	6.60	70	31
2.60	43	14	6.70	70	31
2.65	43	14	6.80	74	34
2.70	46	16	6.90	74	34
2.75	46	16	7.00	74	34
2.80	46	16	7.10	74	34
2.85	46	16	7.20	74	34
2.90	46	16	7.30	74	34
2.95	46	16	7.40	74	34
3.00	46	16	7.50	79	37
3.10	49	18	7.60	79	37
3.20	49	18	7.70	79	37
3.30	49	18	7.80	79	37
3.40	52	20	7.90	79	37
3.50	52	20	8.00	79	37
3.60	52	20	8.20	79	37
3.70	52	20	8.50	79	37
3.80	55	22	8.80	84	40
3.90	55	22	9.00	84	40
4.00	55	22	9.20	84	40
4.10	55	22	9.50	84	40
4.20	55	22	9.80	89	43
4.30	58	24	10.00	89	43
4.40	58	24			

Revêtement sur demande
Beschichtung auf Anfrage
Coating on request

Forets à hélice progressive en métal dur
Vollhartmetall Bohrer mit progressiver Spirale
Solid carbide twist drills with progressive spiral

Type WINNER	Art. N° 2005	R
DIN 1897		

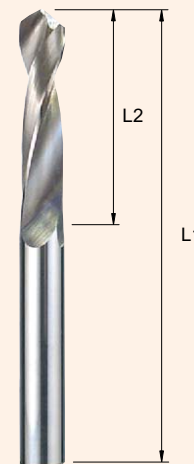

D h6	L1	L2	D h6	L1	L2
1.50	32	9	4.50	58	24
1.55	34	10	4.60	58	24
1.60	34	10	4.70	58	24
1.65	34	10	4.80	62	26
1.70	34	10	4.90	62	26
1.75	36	11	5.00	62	26
1.80	36	11	5.10	62	26
1.85	36	11	5.20	62	26
1.90	36	11	5.30	62	26
1.95	38	12	5.40	66	28
2.00	38	12	5.50	66	28
2.05	38	12	5.60	66	28
2.10	38	12	5.70	66	28
2.15	40	13	5.80	66	28
2.20	40	13	5.90	66	28
2.25	40	13	6.00	66	28
2.30	40	13	6.10	70	31
2.35	40	13	6.20	70	31
2.40	43	14	6.30	70	31
2.45	43	14	6.40	70	31
2.50	43	14	6.50	70	31
2.55	43	14	6.60	70	31
2.60	43	14	6.70	70	31
2.65	43	14	6.80	74	34
2.70	46	16	6.90	74	34
2.75	46	16	7.00	74	34
2.80	46	16	7.10	74	34
2.85	46	16	7.20	74	34
2.90	46	16	7.30	74	34
2.95	46	16	7.40	74	34
3.00	46	16	7.50	79	37
3.10	49	18	7.60	79	37
3.20	49	18	7.70	79	37
3.30	49	18	7.80	79	37
3.40	52	20	7.90	79	37
3.50	52	20	8.00	79	37
3.60	52	20	8.20	79	37
3.70	52	20	8.50	79	37
3.80	55	22	8.80	84	40
3.90	55	22	9.00	84	40
4.00	55	22	9.20	84	40
4.10	55	22	9.50	84	40
4.20	55	22	9.80	89	43
4.30	58	24	10.00	89	43
4.40	58	24			

Revêtement sur demande
Beschichtung auf Anfrage
Coating on request

Forets à hélice progressive en métal dur
Vollhartmetall Bohrer mit progressiver Spirale
Solid carbide twist drills with progressive spiral

Type
WINNER
DIN 338

Art. N°
1006

L

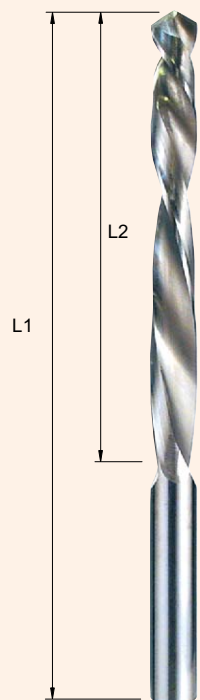

D h6	L1	L2	D h6	L1	L2
1.50	40	18	4.50	80	47
1.55	43	20	4.60	80	47
1.60	43	20	4.70	80	47
1.65	43	20	4.80	86	52
1.70	43	20	4.90	86	52
1.75	46	22	5.00	86	52
1.80	46	22	5.10	86	52
1.85	46	22	5.20	86	52
1.90	46	22	5.30	86	52
1.95	49	24	5.40	93	57
2.00	49	24	5.50	93	57
2.05	49	24	5.60	93	57
2.10	49	24	5.70	93	57
2.15	53	27	5.80	93	57
2.20	53	27	5.90	93	27
2.25	53	27	6.00	93	27
2.30	53	27			
2.35	53	27			
2.40	57	30			
2.45	57	30			
2.50	57	30			
2.55	57	30			
2.60	57	30			
2.65	57	30			
2.70	61	33			
2.75	61	33			
2.80	61	33			
2.85	61	33			
2.90	61	33			
2.95	61	33			
3.00	61	33			
3.10	65	36			
3.20	65	36			
3.30	65	36			
3.40	70	39			
3.50	70	39			
3.60	70	39			
3.70	70	39			
3.80	75	43			
3.90	75	43			
4.00	75	43			
4.10	75	43			
4.20	75	43			
4.30	80	47			
4.40	80	47			

Revêtement sur demande
Beschichtung auf Anfrage
Coating on request

Forets à hélice progressive en métal dur
Vollhartmetall Bohrer mit progressiver Spirale
Solid carbide twist drills with progressive spiral

Type
WINNER
DIN 338

Art. N°
2006

R



D h6	L1	L2	D h6	L1	L2
1.50	40	18	4.50	80	47
1.55	43	20	4.60	80	47
1.60	43	20	4.70	80	47
1.65	43	20	4.80	86	52
1.70	43	20	4.90	86	52
1.75	46	22	5.00	86	52
1.80	46	22	5.10	86	52
1.85	46	22	5.20	86	52
1.90	46	22	5.30	86	52
1.95	49	24	5.40	93	57
2.00	49	24	5.50	93	57
2.05	49	24	5.60	93	57
2.10	49	24	5.70	93	57
2.15	53	27	5.80	93	57
2.20	53	27	5.90	93	57
2.25	53	27	6.00	93	57
2.30	53	27			
2.35	53	27			
2.40	57	30			
2.45	57	30			
2.50	57	30			
2.55	57	30			
2.60	57	30			
2.65	57	30			
2.70	61	33			
2.75	61	33			
2.80	61	33			
2.85	61	33			
2.90	61	33			
2.95	61	33			
3.00	61	33			
3.10	65	36			
3.20	65	36			
3.30	65	36			
3.40	70	39			
3.50	70	39			
3.60	70	39			
3.70	70	39			
3.80	75	43			
3.90	75	43			
4.00	75	43			
4.10	75	43			
4.20	75	43			
4.30	80	47			
4.40	80	47			

Revêtement sur demande
Beschichtung auf Anfrage
Coating on request

Forets à hélice partielle en métal dur
Vollhartmetall Bohrer mit Spiralspitze
Solid carbide drills with partial spiral

Type THOR DIN 1897	Art. N° 2000	R
-----------------------	-----------------	---

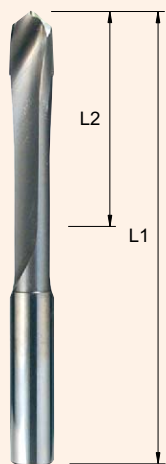

D h6	L1	L2	D h6	L1	L2
1.50	32	9	4.50	58	24
1.55	34	10	4.60	58	24
1.60	34	10	4.70	58	24
1.65	34	10	4.80	62	26
1.70	34	10	4.90	62	26
1.75	36	11	5.00	62	26
1.80	36	11	5.10	62	26
1.85	36	11	5.20	62	26
1.90	36	11	5.30	62	26
1.95	38	12	5.40	66	28
2.00	38	12	5.50	66	28
2.05	38	12	5.60	66	28
2.10	38	12	5.70	66	28
2.15	40	13	5.80	66	28
2.20	40	13	5.90	66	28
2.25	40	13	6.00	66	28
2.30	40	13	6.10	70	31
2.35	40	13	6.20	70	31
2.40	43	14	6.30	70	31
2.45	43	14	6.40	70	31
2.50	43	14	6.50	70	31
2.55	43	14	6.60	70	31
2.60	43	14	6.70	70	31
2.65	43	14	6.80	74	34
2.70	46	16	6.90	74	34
2.75	46	16	7.00	74	34
2.80	46	16	7.10	74	34
2.85	46	16	7.20	74	34
2.90	46	16	7.30	74	34
2.95	46	16	7.40	74	34
3.00	46	16	7.50	79	37
3.10	49	18	7.60	79	37
3.20	49	18	7.70	79	37
3.30	49	18	7.80	79	37
3.40	52	20	7.90	79	37
3.50	52	20	8.00	79	37
3.60	52	20	8.20	79	37
3.70	52	20	8.50	79	37
3.80	55	22	8.80	84	40
3.90	55	22	9.00	84	40
4.00	55	22	9.20	84	40
4.10	55	22	9.50	84	40
4.20	55	22	9.80	89	43
4.30	58	24	10.00	89	43
4.40	58	24			

Revêtement sur demande
Beschichtung auf Anfrage
Coating on request

Forets à hélice partielle en métal dur
Vollhartmetall Bohrer mit Spiralspitze
Solid carbide drills with partial spiral

Type THOR DIN 338	Art. N° 2001	R
----------------------	-----------------	---



D h6	L1	L2	D h6	L1	L2
2.00	49	24	5.20	86	52
2.05	49	24	5.30	86	52
2.10	49	24	5.40	93	57
2.15	53	27	5.50	93	57
2.20	53	27	5.60	93	57
2.25	53	27	5.70	93	57
2.30	53	27	5.80	93	57
2.35	53	27	5.90	93	57
2.40	57	30	6.00	93	57
2.45	57	30			
2.50	57	30			
2.55	57	30			
2.60	57	30			
2.65	57	30			
2.70	61	33			
2.75	61	33			
2.80	61	33			
2.85	61	33			
2.90	61	33			
2.95	61	33			
3.00	61	33			
3.10	65	36			
3.20	65	36			
3.30	65	36			
3.40	70	39			
3.50	70	39			
3.60	70	39			
3.70	70	39			
3.80	75	43			
3.90	75	43			
4.00	75	43			
4.10	75	43			
4.20	75	43			
4.30	80	47			
4.40	80	47			
4.50	80	47			
4.60	80	47			
4.70	80	47			
4.80	86	52			
4.90	86	52			
5.00	86	52			
5.10	86	52			

Revêtement sur demande
Beschichtung auf Anfrage
Coating on request

Burins intérieurs en métal dur
Vollhartmetall Innendrehwerkzeuge
Solid carbide internal turning tools

Type 1600

L

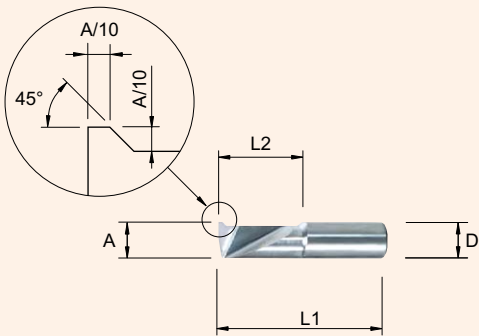

A ^{-0.05}	D	L1	L2	Art. N°
2	3	13	4	1600-2-4
3	3	15	6	1600-3-6
4	4	17	8	1600-4-8
4	4	21	12	1600-4-12
5	5	21	10	1600-5-10
5	5	26	15	1600-5-15
6	6	25	12	1600-6-12
6	6	31	18	1600-6-18
8	8	32	16	1600-8-16
8	8	40	24	1600-8-24

Type 1610

L

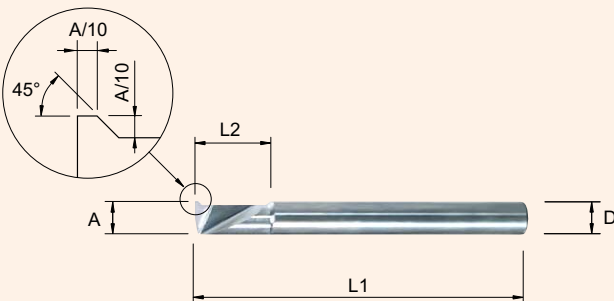

A ^{-0.05}	D	L1	L2	Art. N°
2	3	38	4	1610-2-4
3	3	38	6	1610-3-6
4	4	40	8	1610-4-8
4	4	40	12	1610-4-12
5	5	50	10	1610-5-10
5	5	54	15	1610-5-15
6	6	50	12	1610-6-12
6	6	57	18	1610-6-18
8	8	58	16	1610-8-16
8	8	63	24	1610-8-24

Fraises à angler coniques en métal dur
Vollhartmetall Kegelsenker
Solid carbide chamfering tools

Type 1901

Z=4

L

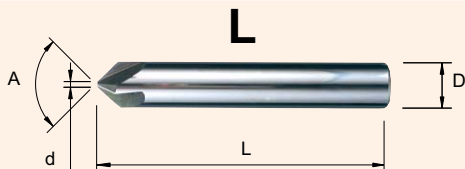

A	D	d	L	Art. N°
90°	3.0	0.3	38	1901-3
90°	6.0	0.7	50	1901-6
90°	8.0	1.2	58	1901-8
90°	12.0	1.6	73	1901-12

Revêtement sur demande
Beschichtung auf Anfrage
Coating on request

Burins intérieurs en métal dur
Vollhartmetall Innendrehwerkzeuge
Solid carbide internal turning tools

Type 2620

R

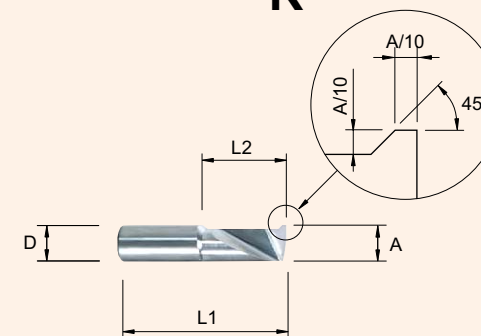

A ^{-0.05}	D	L1	L2	Art. N°
2	3	13	4	2620-2-4
3	3	15	6	2620-3-6
4	4	17	8	2620-4-8
4	4	21	12	2620-4-12
5	5	21	10	2620-5-10
5	5	26	15	2620-5-15
6	6	25	12	2620-6-12
6	6	31	18	2620-6-18
8	8	32	16	2620-8-16
8	8	40	24	2620-8-24

Type 2630

R

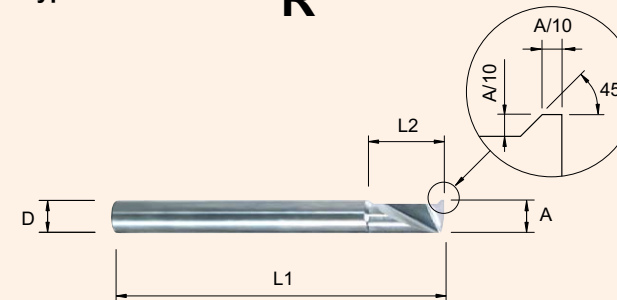

A ^{-0.05}	D	L1	L2	Art. N°
2	3	38	4	2630-2-4
3	3	38	6	2630-3-6
4	4	40	8	2630-4-8
4	4	40	12	2630-4-12
5	5	50	10	2630-5-10
5	5	54	15	2630-5-15
6	6	50	12	2630-6-12
6	6	57	18	2630-6-18
8	8	58	16	2630-8-16
8	8	63	24	2630-8-24
10	10	72	30	2630-10-30
12	12	83	36	2630-12-36

Fraises à angler coniques en métal dur
Vollhartmetall Kegelsenker
Solid carbide chamfering tools

Type 3901

Z=4

R



A	D	d	L	Art. N°
90°	3.0	0.3	38	3901-3
90°	6.0	0.7	50	3901-6
90°	8.0	1.2	58	3901-8
90°	12.0	1.6	73	3901-12

Type 3911

Z=3

R

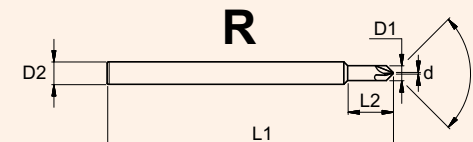

A	D1	d	D2 h6	L1	L2	Art. N°
90°	1.0	0.1	3.0	39	3	3911-1.0
90°	1.5	0.1	3.0	39	4.5	3911-1.5
90°	2.0	0.1	3.0	39	6	3911-2.0
90°	2.5	0.1	3.0	39	7.5	3911-2.5

Revêtement sur demande
Beschichtung auf Anfrage
Coating on request

Alésoirs en métal dur
VHM-Reibahlen
Solid carbide reamers

Type 2100

Coupe à droite, hélice à gauche 8°
Rechtsschneidend, linksdrall 8°
Right-hand cut, left-hand spiral 8°

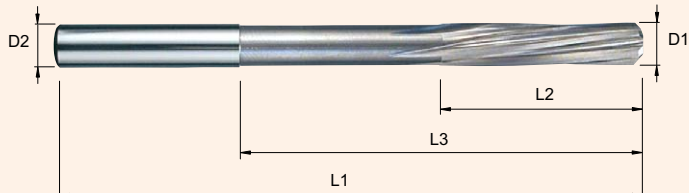

nombre de dents
Zähnezahl
number of teeth

0.97 - 4.50 → Z = 4
4.60 - 12.0 → Z = 6

Tolérance D1
D1-Toleranz
Tolerance D1

Ø	0.97 - 3.03	→ 0 / +0.003
	3.10 - 10.03	→ 0 / +0.004
Ø H7	1.0H7 - 3.0H7	→ +0.004 / +0.008
= ~ 40% tol. (VSM 34306)	3.5H7 - 6.0H7	→ +0.005 / +0.010
	6.5H7 - 10.0H7	→ +0.006 / +0.012
	11.0H7 - 12.0H7	→ +0.008 / +0.015

D1	D2	L1	L2	L3	D1	D2	L1	L2	L3	D1	D2	L1	L2	L3	D1	D2	L1	L2	L3
0.97	1.5	50	15	30	2.52	2.5	50	15	30	4.50	4.5	60	20	40	6.99	7.0	100	30	65
0.98	1.5	50	15	30	2.53	2.5	50	15	30	4.5H7	4.5	60	20	40	7.00	7.0	100	30	65
0.99	1.5	50	15	30	2.60	3.0	60	20	40	4.60	5.0	75	25	50	7.0H7	7.0	100	30	65
1.00	1.5	50	15	30	2.70	3.0	60	20	40	4.70	5.0	75	25	50	7.01	7.0	100	30	65
1.0H7	1.5	50	15	30	2.80	3.0	60	20	40	4.80	5.0	75	25	50	7.02	7.0	100	30	65
1.01	1.5	50	15	30	2.90	3.0	60	20	40	4.90	5.0	75	25	50	7.03	7.0	100	30	65
1.02	1.5	50	15	30	2.97	3.0	60	20	40	4.97	5.0	75	25	50	7.97	8.0	100	30	65
1.03	1.5	50	15	30	2.98	3.0	60	20	40	4.98	5.0	75	25	50	7.98	8.0	100	30	65
1.10	1.5	50	15	30	2.99	3.0	60	20	40	4.99	5.0	75	25	50	7.99	8.0	100	30	65
1.20	1.5	50	15	30	3.00	3.0	60	20	40	5.00	5.0	75	25	50	8.00	8.0	100	30	65
1.30	1.5	50	15	30	3.0H7	3.0	60	20	40	5.0H7	5.0	75	25	50	8.0H7	8.0	100	30	65
1.40	1.5	50	15	30	3.01	3.0	60	20	40	5.01	5.0	75	25	50	8.01	8.0	100	30	65
1.50	1.5	50	15	30	3.02	3.0	60	20	40	5.02	5.0	75	25	50	8.02	8.0	100	30	65
1.5H7	1.5	50	15	30	3.03	3.0	60	20	40	5.03	5.0	75	25	50	8.03	8.0	100	30	65
1.60	2.0	50	15	30	3.10	3.5	60	20	40	5.10	6.0	75	25	50	8.97	9.0	100	30	65
1.70	2.0	50	15	30	3.20	3.5	60	20	40	5.20	6.0	75	25	50	8.98	9.0	100	30	65
1.80	2.0	50	15	30	3.30	3.5	60	20	40	5.30	6.0	75	25	50	8.99	9.0	100	30	65
1.90	2.0	50	15	30	3.40	3.5	60	20	40	5.40	6.0	75	25	50	9.00	9.0	100	30	65
1.97	2.0	50	15	30	3.50	3.5	60	20	40	5.50	6.0	75	25	50	9.0H7	9.0	100	30	65
1.98	2.0	50	15	30	3.5H7	3.5	60	20	40	5.5H7	6.0	75	25	50	9.01	9.0	100	30	65
1.99	2.0	50	15	30	3.60	4.0	60	20	40	5.60	6.0	75	25	50	9.02	9.0	100	30	65
2.00	2.0	50	15	30	3.70	4.0	60	20	40	5.70	6.0	75	25	50	9.03	9.0	100	30	65
2.0H7	2.0	50	15	30	3.80	4.0	60	20	40	5.80	6.0	75	25	50	9.97	10.0	100	30	65
2.01	2.0	50	15	30	3.90	4.0	60	20	40	5.90	6.0	75	25	50	9.98	10.0	100	30	65
2.02	2.0	50	15	30	3.97	4.0	60	20	40	5.97	6.0	75	25	50	9.99	10.0	100	30	65
2.03	2.0	50	15	30	3.98	4.0	60	20	40	5.98	6.0	75	25	50	10.00	10.0	100	30	65
2.10	2.5	50	15	30	3.99	4.0	60	20	40	5.99	6.0	75	25	50	10.0H7	10.0	100	30	65
2.20	2.5	50	15	30	4.00	4.0	60	20	40	6.00	6.0	75	25	50	10.01	10.0	100	30	65
2.30	2.5	50	15	30	4.0H7	4.0	60	20	40	6.0H7	6.0	75	25	50	10.02	10.0	100	30	65
2.40	2.5	50	15	30	4.01	4.0	60	20	40	6.01	6.0	75	25	50	10.03	10.0	100	30	65
2.47	2.5	50	15	30	4.02	4.0	60	20	40	6.02	6.0	75	25	50	11.0H7	11.0	100	30	65
2.48	2.5	50	15	30	4.03	4.0	60	20	40	6.03	6.0	75	25	50	12.0H7	12.0	100	30	65
2.49	2.5	50	15	30	4.10	4.5	60	20	40	6.50	7.0	75	25	50					
2.50	2.5	50	15	30	4.20	4.5	60	20	40	6.5H7	7.0	75	25	50					
2.5H7	2.5	50	15	30	4.30	4.5	60	20	40	6.97	7.0	100	30	65					
2.51	2.5	50	15	30	4.40	4.5	60	20	40	6.98	7.0	100	30	65					

Revêtement sur demande
Beschichtung auf Anfrage
Coating on request

Micro-fraises de précision en métal dur
Vollhartmetall Micropräzisionsfräser
Solid carbide precision micro end mills

Type 3271

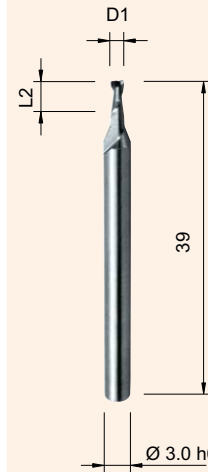

D1 +/- 0.015	L2	D1 +/- 0.015	L2
0.2		1.6	4
0.3	1	1.7	5
0.4	1	1.8	5
0.5	1.5	1.9	5
0.6	1.5	2.0	5
0.7	2	2.1	5
0.75	2	2.2	5
0.8	2	2.3	7
0.9	2.5	2.4	7
1.0	3	2.5	7
1.1	3	2.6	7
1.2	4	2.7	7
1.3	4	2.8	7
1.4	4	2.9	7
1.5	4		

Z=2 coupe au centre
Zentrumsschnitt
cut over center
30° hélice
Drall
spiral

Type 3274

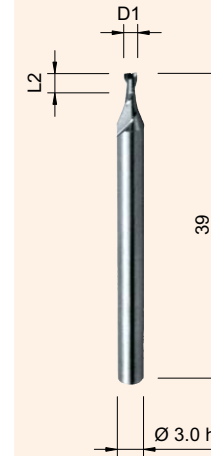

D1 +/- 0.015	L2	D1 +/- 0.015	L2
0.2	0.3	1.1	1.65
0.25	0.35	1.2	1.8
0.3	0.45	1.3	1.95
0.4	0.6	1.4	2.1
0.5	0.75	1.5	2.25
0.6	0.9	1.6	2.4
0.7	1.05	1.7	2.55
0.8	1.2	1.8	2.7
0.9	1.35	1.9	2.85
1.0	1.5	2.0	3.0

Z=2 coupe au centre
Zentrumsschnitt
cut over center
30° hélice
Drall
spiral
extra-courte
Extra kurz
extra short

Type 3371

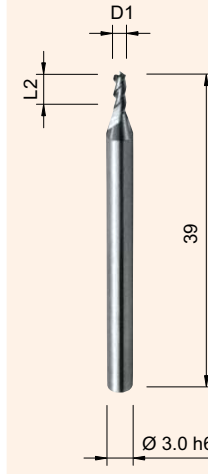

D1 +/- 0.015	L2	D1 +/- 0.015	L2
0.5	1.5	1.7	5
0.6	1.5	1.8	5
0.7	2	1.9	5
0.75	2	2.0	5
0.8	2	2.1	5
0.9	2.5	2.2	5
1.0	3	2.3	7
1.1	3	2.4	7
1.2	4	2.5	7
1.3	4	2.6	7
1.4	4	2.7	7
1.5	4	2.8	7
1.6	4	2.9	7

Z=3 coupe au centre
Zentrumsschnitt
cut over center
30° hélice
Drall
spiral

Type 3374

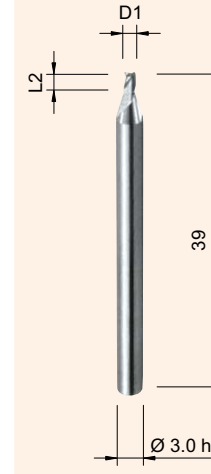

D1 +/- 0.015	L2	D1 +/- 0.015	L2
0.4	0.6	1.4	1.8
0.45	0.7	1.5	1.8
0.5	0.7	1.6	2.0
0.6	0.8	1.7	2.0
0.7	0.9	1.8	2.0
0.8	1.0	1.9	2.4
0.9	1.3	2.0	2.4
1.0	1.3	2.2	2.6
1.1	1.6	2.5	3.0
1.2	1.6	2.8	3.5
1.3	1.8	2.9	3.5

Z=3 coupe au centre
Zentrumsschnitt
cut over center
30° hélice
Drall
spiral
extra-courte
Extra kurz
extra short

Revêtement sur demande
Beschichtung auf Anfrage
Coating on request

Micro-fraises de précision en métal dur
Vollhartmetall Micropräzisionsfräser
Solid carbide precision micro end mills

Type 3278

hémisphérique
Stirnradius
ball end

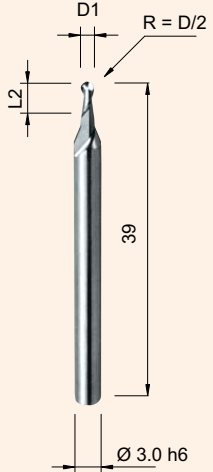

D1 +/- 0.015	L2	D1 +/- 0.015	L2
0.3	1	1.4	4
0.4	1	1.5	4
0.5	1.5	1.6	4
0.6	1.5	1.8	5
0.7	2	2.0	7
0.8	2	2.2	7
0.9	2.5	2.5	7
1.0	3	2.8	7
1.2	4		

Type 3279

hémisphérique, extra-courte
Stirnradius, Extra kurz
ball end, extra short

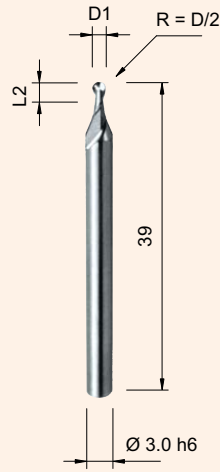

D1 +/- 0.015	L2	D1 +/- 0.015	L2
0.2	0.3	1.0	1.5
0.25	0.35	1.1	1.65
0.3	0.45	1.2	1.8
0.4	0.6	1.3	1.95
0.5	0.75	1.4	2.1
0.6	0.9	1.5	2.25
0.7	1.05	1.6	2.4
0.8	1.2	1.8	2.7
0.9	1.35	2.0	3.0

Z=2

coupe au centre
Zentrumsschnitt
cut over center

30°

hélice
Drall
spiral

Z=2

coupe au centre
Zentrumsschnitt
cut over center

30°

hélice
Drall
spiral

Micro-fraises de précision en métal dur
Vollhartmetall-Micropräzisionsfräser
Solid carbide precision micro end mills

Type 3335

extra-courte
Extra kurz
extra short

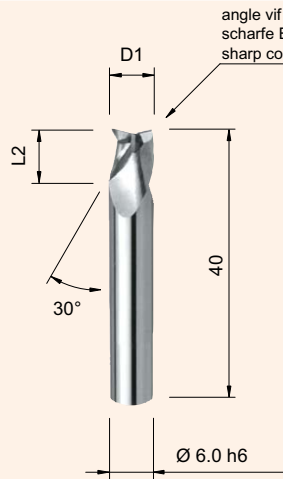

D1 +/- 0.015	L2	D1 +/- 0.015	L2
1.5	3	4.0	5
2.0	3	4.5	5
2.5	3	5.0	6
3.0	4	6.0	7
3.5	4		

Z=3

coupe au centre
Zentrumsschnitt
cut over center

Revêtement sur demande
Beschichtung auf Anfrage
Coating on request

Fraises en bout en métal dur
VHM-Schaftfräser
Solid carbide end mills

Type 3231	Type 3238	Type 3331	Type 3338	Type 3341	Type 3361	Type 3431	Type 3441	dimensions Abmessungen dimensions		
Z = 2 a = 30°	Z = 2 a = 30°	Z = 3 a = 30°	Z = 3 a = 30°	Z = 3 a = 45°	Z = 3 a = 60°	Z = 4 a = 30°	Z = 4 a = 45°	D1 h10 D2 h6	L1	L2
-	R = D1 / 2	-	R = D1 / 2	-	-	-	-	2.0	32	8
								2.5	32	8
								3.0	32	12
								3.5	32	12
								4.0	40	12
								4.5	50	14
								5.0	50	14
								6.0	50	16
								7.0	60	20
								8.0	60	20
								9.0	60	20
								10.0	70	22
								12.0	70	22

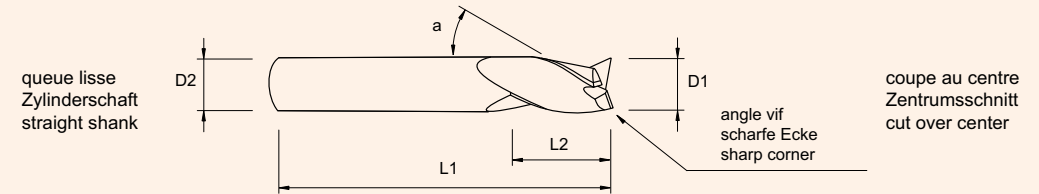

Type 3336 DIN 6527 K

Z = 3

coupe au centre
Zentrumsschnitt
cut over center

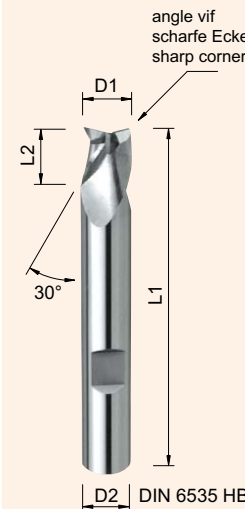

D1 h10	D2 h6	L1	L2
1.5	6.0	50	3
1.8	6.0	50	3
2.0	6.0	50	3
2.5	6.0	50	3
2.8	6.0	50	4
3.0	6.0	50	4
3.5	6.0	50	4
3.8	6.0	54	5
4.0	6.0	54	5
4.5	6.0	54	5
4.8	6.0	54	6
5.0	6.0	54	6
5.5	6.0	54	7
5.8	6.0	54	7
6.0	6.0	54	7
7.0	8.0	58	8
8.0	8.0	58	9
9.0	10.0	66	10
10.0	10.0	66	11
12.0	12.0	73	12

Type 3337 DIN 6527 L

angle vif scharfe Ecke
sharp corner

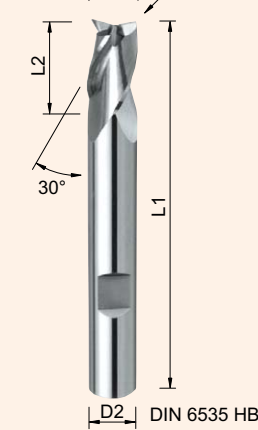

D1 h10	D2 h6	L1	L2
2.0	6.0	57	6
2.5	6.0	57	6
3.0	6.0	57	7
3.5	6.0	57	7
4.0	6.0	57	8
4.5	6.0	57	8
5.0	6.0	57	10
6.0	6.0	57	10
8.0	8.0	63	16
10.0	10.0	72	19
12.0	12.0	83	22

Z = 3

coupe au centre
Zentrumsschnitt
cut over center

Revêtement sur demande
Beschichtung auf Anfrage
Coating on request

Fraises en bout en métal dur pour usinage en bout plat
 VHM-Schaftfräser für flache Frontbearbeitung
 Solid carbide end mills for flat front machining

Type 3281

Type 3381

dimensions
 Abmessungen
 dimensions

Z = 2



Z = 3

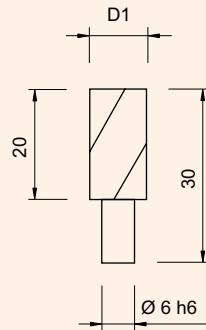

D1 h10

- 6.0
- 8.0
- 10.0
- 12.0

coupe au centre
 Zentrumschnitt
 cut over center

30° hélice
 Drall
 spiral

Type 3282

Type 3382

dimensions
 Abmessungen
 dimensions

Z = 2

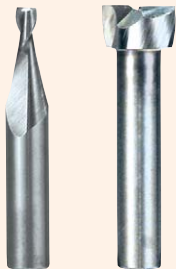

Z = 3

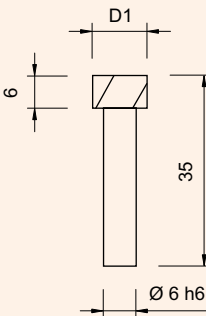
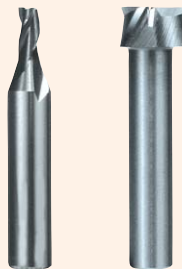

D1 h10 D1 h10

- | | |
|-----|------|
| 3.0 | 6.0 |
| 3.5 | 7.0 |
| 4.0 | 8.0 |
| 4.5 | 10.0 |
| 5.0 | 12.0 |
| 5.5 | |

coupe au centre
 Zentrumschnitt
 cut over center

30° hélice
 Drall
 spiral

Type 3283

Type 3383

dimensions
 Abmessungen
 dimensions

Z = 2



Z = 3

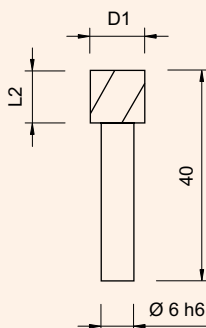
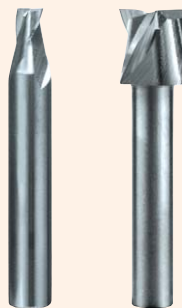

D1 h10 L2

- | | |
|------|----|
| 4.0 | 4 |
| 5.0 | 5 |
| 6.0 | 6 |
| 7.0 | 7 |
| 8.0 | 8 |
| 10.0 | 10 |
| 12.0 | 12 |

coupe au centre
 Zentrumschnitt
 cut over center

30° hélice
 Drall
 spiral

Revêtement sur demande
 Beschichtung auf Anfrage
 Coating on request

Fraises en bout en métal dur pour usinage en bout plat
 VHM-Schaftfräser für flache Frontbearbeitung
 Solid carbide end mills for flat front machining

Type 3384 *new*

dimensions
 Abmessungen
 dimensions

Z = 3

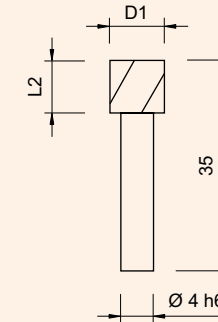
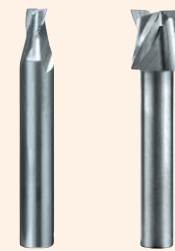

coupe au centre
 Zentrumschnitt
 cut over center

30° hélice
 Drall
 spiral

D1 h10	L2
3.0	6
4.0	6
5.0	6
6.0	6
8.0	6

Fraises en bout en métal dur pour usinage de cames
 Vollhartmetall Schaftfräser für Kurvenbearbeitung
 Solid carbide end mills for came machining

Z = 3

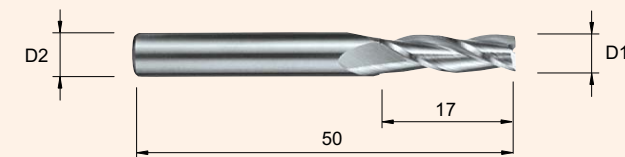

D1	D2 h6	Art. N°
5.0	5.0	3801
5.2	6.0	3802
6.0	6.0	3803

DIN 6535 HB

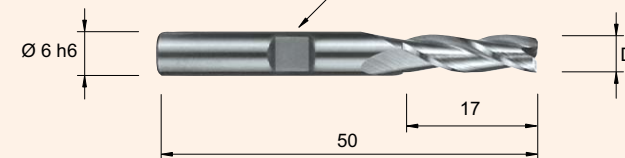

D1	Art. N°
5.2	3812
6.0	3813

Z = 6



D1	Art. N°
4.2	3821
5.2	3822

Z = 10

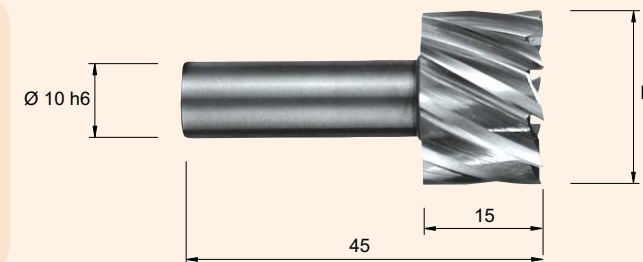

D1	Art. N°
16.3	3831
18.3	3832
20.3	3833
22.3	3834
24.3	3835

Molettes en métal dur
Vollhartmetall Rändelrädchen
Solid carbide knurling wheels

Type 1107



AA



BL

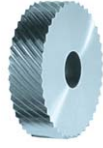

BR



GE

molettes standard standard Rändelrädchen standard knurls	Ø	épaisseur Dicke thickness	alésage Bohrung bore	pas (tous les 0.1 mm) Teilung (alle 0.1 mm) pitch (every 0.1 mm)	
AA (0°)	8	2	3	0.2 - 0.6	
	8	2	4	0.2 - 0.6	
	8	3	3	0.2 - 0.6	
	8	3	4	0.2 - 0.6	
	8	4	3	0.2 - 0.6	
	8	4	4	0.2 - 0.6	
	10	2	3	0.2 - 0.8	
	10	2	4	0.2 - 0.8	
	10	3	3	0.2 - 0.8	
	10	3	4	0.2 - 0.8	
	10	4	3	0.2 - 0.8	
	10	4	4	0.2 - 0.8	
	BL 15° / BR 15° BL 30° / BR 30° BL 45° / BR 45°	12	4	4	0.3 - 1.0
		15	4	4	0.4 - 1.0
		15	4	5	0.4 - 1.0
		15	5	4	0.4 - 1.0
		15	5	5	0.4 - 1.0
		20	4	5	0.5 - 1.2
GE 30° GE 45°	20	5	5	0.5 - 1.2	
	20	6	6	0.5 - 1.2	
	20	8	6	0.5 - 1.2	

molettes "Quick" "Quick"-Rändelrädchen "Quick" knurling wheels	Ø	épaisseur Dicke thickness	alésage Bohrung bore	pas (tous les 0.1 mm) Teilung (alle 0.1 mm) pitch (every 0.1 mm)
AA (0°)	8.9	2.5	4	0.2 - 0.8
BL 15° / BR 15°	14.5	3	5	0.4 - 1.0
BL 30° / BR 30°	21.5	5	8	0.5 - 1.2

Exécutions spéciales sur demande
Sonderausführungen auf Anfrage
Specials execution on request

Porte-molettes
Rändelhalter
Knurl holders

Type 2402

R

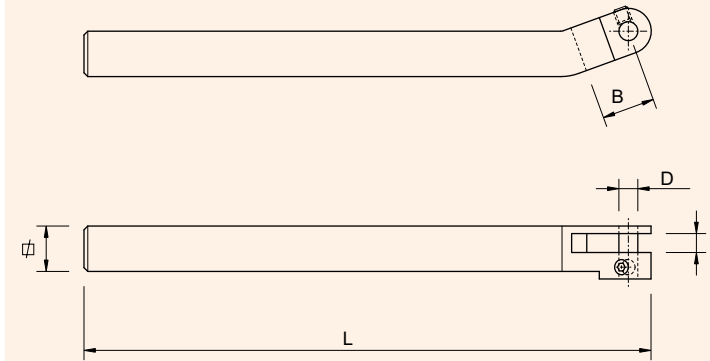

Type 1402

L

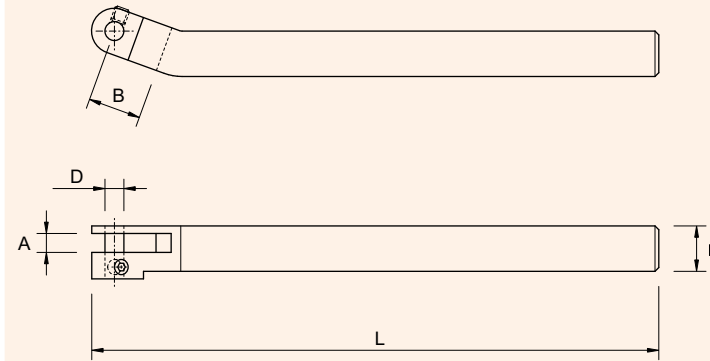

Ø	L	A	D	B	Art. N°
6 x 6	132	2	3	10	2402-623
6 x 6	132	3	3	10	2402-633
7 x 7	140	2	3	10	2402-723
7 x 7	140	3	3	10	2402-733
7 x 7	140	4	3	10	2402-743
7 x 7	140	2	4	10	2402-724
7 x 7	140	3	4	10	2402-734
7 x 7	140	4	4	10	2402-744
8 x 8	140	2	3	10	2402-823
8 x 8	140	3	3	10	2402-833
8 x 8	140	4	3	10	2402-843
8 x 8	140	2	4	10	2402-824
8 x 8	140	3	4	10	2402-834
8 x 8	140	4	4	10	2402-844
10 x 10	150	3	3	10	2402-1033
10 x 10	150	4	3	10	2402-1043
10 x 10	150	3	4	10	2402-1034
10 x 10	150	4	4	10	2402-1044
12 x 12	150	4	4	12	2402-1244
12 x 12	150	5	4	12	2402-1254
12 x 12	150	4	5	12	2402-1245
12 x 12	150	5	5	12	2402-1255
16 x 16	150	4	4	12	2402-1644
16 x 16	150	4	5	12	2402-1645
16 x 16	150	5	5	12	2402-1655
16 x 16	150	6	4	12	2402-1664
16 x 16	150	6	6	12	2402-1666
16 x 16	150	8	6	12	2402-1686

Ø	L	A	D	B	Art. N°
6 x 6	132	2	3	10	1402-623
6 x 6	132	3	3	10	1402-633
7 x 7	140	2	3	10	1402-723
7 x 7	140	3	3	10	1402-733
7 x 7	140	4	3	10	1402-743
7 x 7	140	2	4	10	1402-724
7 x 7	140	3	4	10	1402-734
7 x 7	140	4	4	10	1402-744
8 x 8	140	2	3	10	1402-823
8 x 8	140	3	3	10	1402-833
8 x 8	140	4	3	10	1402-843
8 x 8	140	2	4	10	1402-824
8 x 8	140	3	4	10	1402-834
8 x 8	140	4	4	10	1402-844
10 x 10	150	3	3	10	1402-1033
10 x 10	150	4	3	10	1402-1043
10 x 10	150	3	4	10	1402-1034
10 x 10	150	4	4	10	1402-1044
10 x 10	150	5	4	10	1402-1054
12 x 12	150	4	4	12	1402-1244
12 x 12	150	5	4	12	1402-1254
12 x 12	150	4	5	12	1402-1245
12 x 12	150	5	5	12	1402-1255
16 x 16	150	4	4	12	1402-1644

Porte-outils
Werkzeughalter
Tool holders

Type 1400-J L

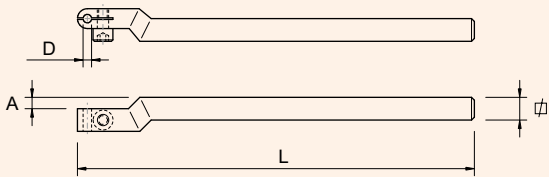

∅	L	A	D	Art. N°
6 x 6	132	3	1.5	1400-J-615
6 x 6	132	3	2.0	1400-J-620
6 x 6	132	3	3.0	1400-J-630
7 x 7	140	3	1.5	1400-J-715
7 x 7	140	3	2.0	1400-J-720
7 x 7	140	3	3.0	1400-J-730
8 x 8	140	4	1.5	1400-J-815
8 x 8	140	4	2.0	1400-J-820
8 x 8	140	4	3.0	1400-J-830

Type 1401-K L

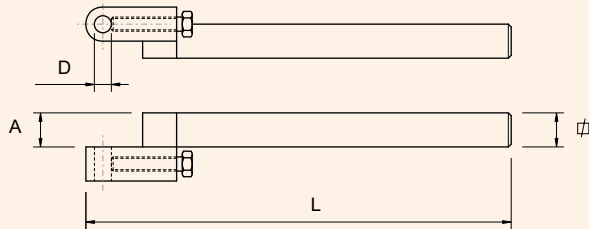

∅	L	A	D	Art. N°
7 x 7	146	7	2.0	1401-K-720
7 x 7	146	7	3.0	1401-K-730
7 x 7	146	7	4.0	1401-K-740
8 x 8	146	8	2.0	1401-K-820
8 x 8	146	8	3.0	1401-K-830
8 x 8	146	8	4.0	1401-K-840
8 x 8	146	8	5.0	1401-K-850
8 x 8	146	8	6.0	1401-K-860
10 x 10	150	10	4.0	1401-K-1040
10 x 10	150	10	5.0	1401-K-1050
10 x 10	150	10	6.0	1401-K-1060
10 x 10	150	10	7.0	1401-K-1070
12 x 12	150	12	4.0	1401-K-1240
12 x 12	150	12	5.0	1401-K-1250
12 x 12	150	12	6.0	1401-K-1260
12 x 12	150	12	8.0	1401-K-1280
14 x 14	150	14	4.0	1401-K-1440
14 x 14	150	14	6.0	1401-K-1460
14 x 14	150	14	8.0	1401-K-1480

Type 1420 L

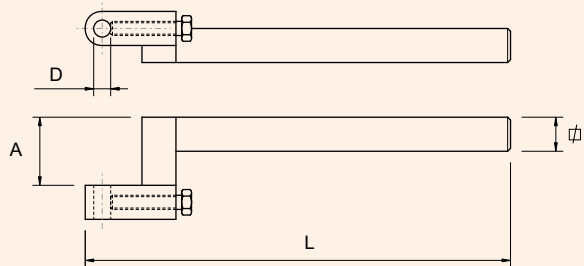

∅	L	A	D	Art. N°
7 x 7	146	12	4.0	1420-7124
8 x 8	146	12	4.0	1420-8124
8 x 8	146	14	3.0	1420-8143
8 x 8	146	15	5.0	1420-8155
8 x 8	146	20	5.0	1420-8205
10 x 10	150	20	6.0	1420-10206
12 x 12	150	18	6.0	1420-12186
12 x 12	150	18	8.0	1420-12188
12 x 12	150	24	8.0	1420-12248
14 x 14	150	20	8.0	1420-14208
14 x 14	150	24	8.0	1420-14248

Porte-outils
Werkzeughalter
Tool holders

Type 2400-J R

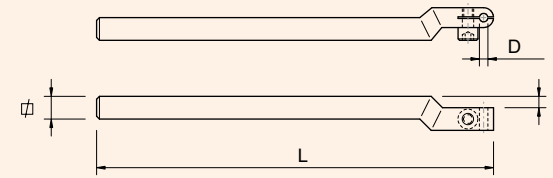

∅	L	A	D	Art. N°
6 x 6	132	3	1.5	2400-J-615
6 x 6	132	3	2.0	2400-J-620
6 x 6	132	3	3.0	2400-J-630
7 x 7	140	3	1.5	2400-J-715
7 x 7	140	3	2.0	2400-J-720
7 x 7	140	3	3.0	2400-J-730
8 x 8	140	4	1.5	2400-J-815
8 x 8	140	4	2.0	2400-J-820
8 x 8	140	4	3.0	2400-J-830

Type 2401-K R

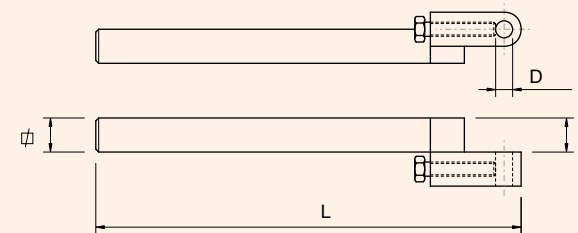

∅	L	A	D	Art. N°
7 x 7	146	7	3.0	2401-K-730
7 x 7	146	7	4.0	2401-K-740
8 x 8	146	8	3.0	2401-K-830
8 x 8	146	8	4.0	2401-K-840
8 x 8	146	8	5.0	2401-K-850
8 x 8	146	8	6.0	2401-K-860
10 x 10	150	10	3.0	2401-K-1030
10 x 10	150	10	4.0	2401-K-1040
10 x 10	150	10	5.0	2401-K-1050
10 x 10	150	10	6.0	2401-K-1060
10 x 10	150	10	7.0	2401-K-1070
12 x 12	150	12	3.0	2401-K-1230
12 x 12	150	12	4.0	2401-K-1240
12 x 12	150	12	5.0	2401-K-1250
12 x 12	150	12	6.0	2401-K-1260
12 x 12	150	12	8.0	2401-K-1280
14 x 14	150	14	4.0	2401-K-1440
14 x 14	150	14	6.0	2401-K-1460
14 x 14	150	14	8.0	2401-K-1480

Type 2420 R

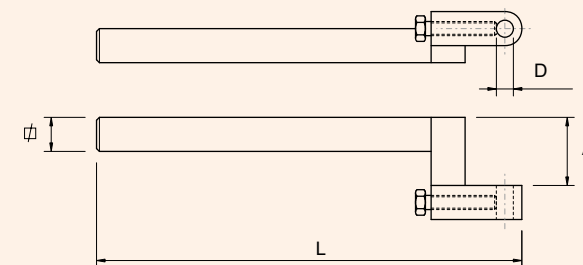

∅	L	A	D	Art. N°
7 x 7	146	12	4.0	2420-7124
8 x 8	146	12	4.0	2420-8124
8 x 8	146	14	3.0	2420-8143
8 x 8	146	15	5.0	2420-8155
8 x 8	146	20	5.0	2420-8205
10 x 10	150	20	6.0	2420-10206
12 x 12	150	18	6.0	2420-12186
12 x 12	150	24	8.0	2420-12248
14 x 14	150	20	8.0	2420-14208
14 x 14	150	24	8.0	2420-14248

Porte-outils
Werkzeughalter
Tool holders

Type 2405

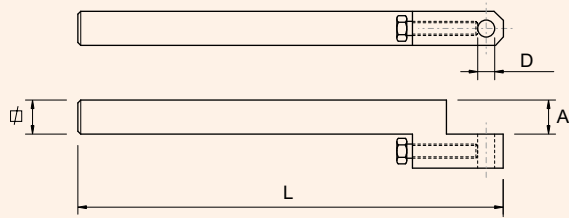

∅	L	A	D	Art. N°
8 x 8	120	8	3.0	2405-K-830
8 x 8	120	8	4.0	2405-K-840
8 x 8	120	8	5.0	2405-K-850
8 x 8	120	8	6.0	2405-K-860
10 x 10	100	10	4.0	2405-K-1040
10 x 10	100	10	5.0	2405-K-1050
10 x 10	100	10	6.0	2405-K-1060
12 x 12	150	12	4.0	2405-K-1240
12 x 12	150	12	6.0	2405-K-1260
12 x 12	150	12	8.0	2405-K-1280

Type 2425

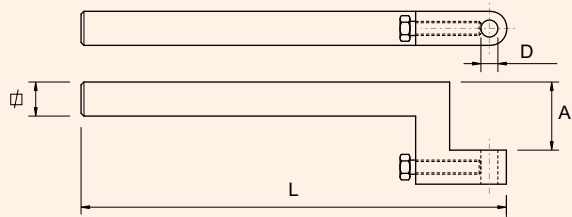

∅	L	A	D	Art. N°
8 x 8	120	12	4.0	2425-8124
8 x 8	120	15	5.0	2425-8155
8 x 8	120	20	5.0	2425-8205
10 x 10	100	15	6.0	2425-10156
10 x 10	100	20	6.0	2425-10206
12 x 12	150	18	6.0	2425-12186
12 x 12	150	24	8.0	2425-12248

Type 1450 special ENC 16/164 L ∅ 12 x 12

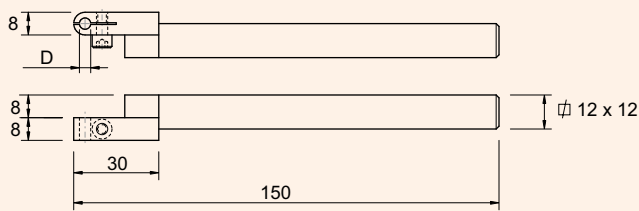

D	Art. N°
4.0	1450-4
5.0	1450-5

Type 1460 special ENC 16/164 L ∅ 12 x 12

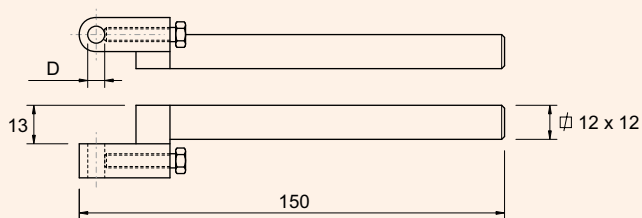

D	Art. N°
4.0	1460-4
5.0	1460-5
6.0	1460-6
8.0	1460-8

Porte-outils
Werkzeughalter
Tool holders

Type 2450-SP R ∅ 10 x 10

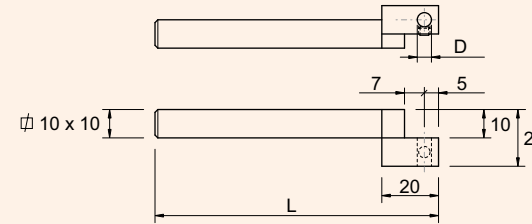

D	L	Art. N°
3.0	100	2450-SP-3
4.0	100	2450-SP-4
5.0	100	2450-SP-5
6.0	100	2450-SP-6
3.0	120	2450-SP-3-120
4.0	120	2450-SP-4-120
5.0	120	2450-SP-5-120
6.0	120	2450-SP-6-120

Type 2470 R ∅ 10 x 10

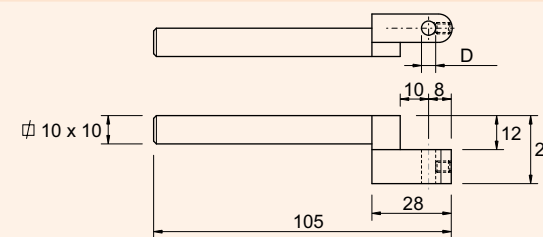

D	Art. N°
3.0	2470-3
4.0	2470-4
5.0	2470-5
6.0	2470-6
7.0	2470-7

Type 2450 R ∅ 12 x 12

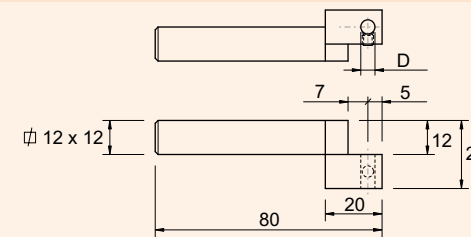

D	Art. N°
3.0	2450-3
4.0	2450-4
5.0	2450-5
6.0	2450-6
8.0	2450-8

Type 2460 R ∅ 12 x 12

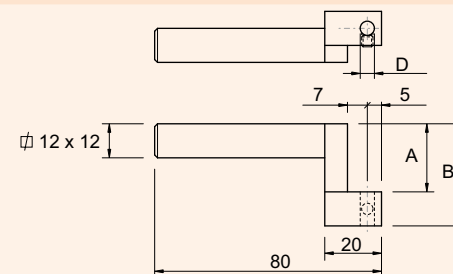

A	B	D	Art. N°
16	28	4.0	2460-284
16	28	6.0	2460-286
16	28	8.0	2460-288
20	32	4.0	2460-324
20	32	6.0	2460-326
20	32	8.0	2460-328
24	36	4.0	2460-364
24	36	6.0	2460-366
24	36	8.0	2460-368

Porte-outils
Werkzeughalter
Tool holders

Type 2441 \varnothing 12 x 16

Pour usinage côté contre-broche
Für die Bearbeitung auf der Gegenspindel-seite
For machining on subspindle side

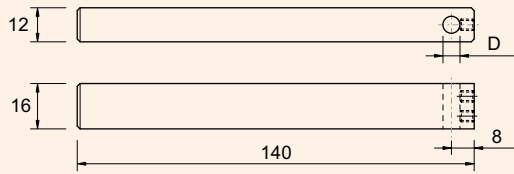

D	Art. N°
3.0	2441-0-3
4.0	2441-0-4
5.0	2441-0-5
6.0	2441-0-6

Type 2440-0 \varnothing 16 x 16

Pour usinage côté contre-broche
Für die Bearbeitung auf der Gegenspindel-seite
For machining on subspindle side

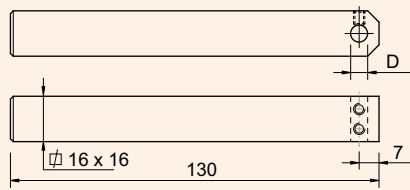

D	Art. N°
3.0	2440-0-3
4.0	2440-0-4
5.0	2440-0-5
6.0	2440-0-6
8.0	2440-0-8

Types 2440-8
2440-12 \varnothing 16 x 16

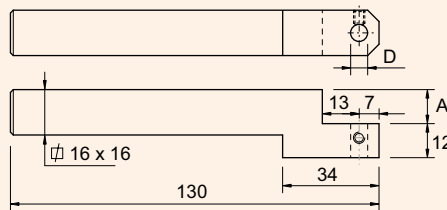

A	D	Art. N°
8	3.0	2440-8-3
8	4.0	2440-8-4
8	5.0	2440-8-5
8	6.0	2440-8-6
8	8.0	2440-8-8
12	3.0	2440-12-3
12	4.0	2440-12-4
12	5.0	2440-12-5
12	6.0	2440-12-6
12	8.0	2440-12-8

Types 2440-18
2440-26 \varnothing 16 x 16

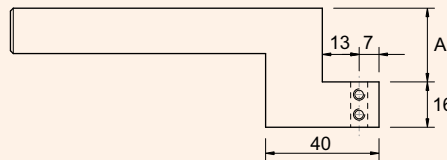

18	4.0	2440-18-4
18	5.0	2440-18-5
18	6.0	2440-18-6
18	8.0	2440-18-8
26	4.0	2440-26-4
26	5.0	2440-26-5
26	6.0	2440-26-6
26	8.0	2440-26-8

Outil d'arrosage
Werkzeug für Kühlmittelzufuhr
Tool for coolant supply

Type 2490 \varnothing 12 x 16

Raccord
Anschluss
connection
 \varnothing 6 - G1/8

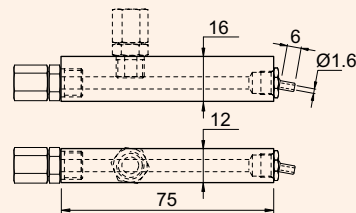

Art. N°
2490

Porte-outils monoblocs pour machine TORNOS DECO 7/10
Monoblockwerkzeughalter für TORNOS DECO 7/10 Maschine
Monobloc tool holders for machine TORNOS DECO 7/10

Type 2435

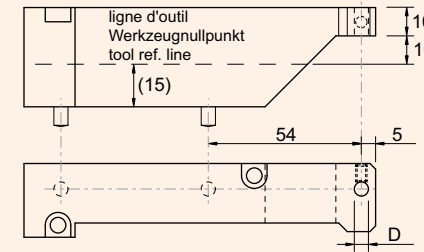

D	Art. N°
3.0	2435-3
4.0	2435-4
5.0	2435-5
6.0	2435-6

Type 2435-T

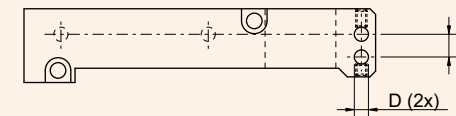

D (2x)	Art. N°
3.0	2435-3-T
4.0	2435-4-T
5.0	2435-5-T
6.0	2435-6-T

Porte-outils monoblocs pour machine TORNOS DECO 7/10
Monoblockwerkzeughalter für TORNOS DECO 7/10 Maschine
Monobloc tool holders for machine TORNOS DECO 7/10

Type 2436

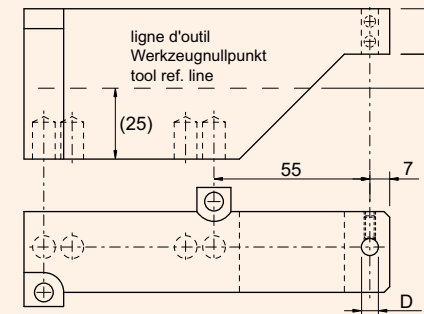

A	D	Art. N°
12	3.0	2436-12-3
12	4.0	2436-12-4
12	5.0	2436-12-5
12	6.0	2436-12-6
12	8.0	2436-12-8
18	3.0	2436-18-3
18	4.0	2436-18-4
18	5.0	2436-18-5
18	6.0	2436-18-6
18	8.0	2436-18-8

Type 2436-T

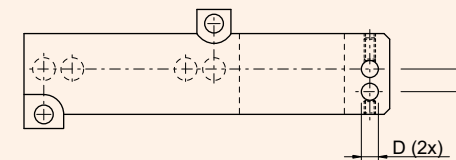

A	D (2x)	Art. N°
12	3.0	2436T-12-3
12	4.0	2436T-12-4
12	5.0	2436T-12-5
12	6.0	2436T-12-6
18	3.0	2436T-18-3
18	4.0	2436T-18-4
18	5.0	2436T-18-5
18	6.0	2436T-18-6

Entretoise
Erhöhungplatte
Spacer

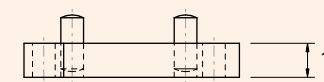

Type 2436-S12

Art. N°
2436-S12

Les avantages
Die Vorteile
The advantages

MODU-LINE

SYSTEME D'OUTILS MODULAIRES
POUR TOURS AUTOMATIQUES

MODULARES WERKZEUGSYSTEM FÜR
LANGDREHAUTOMATEN

MODULAR TOOLING SYSTEM FOR
SLIDING AUTOMATIC LATHES

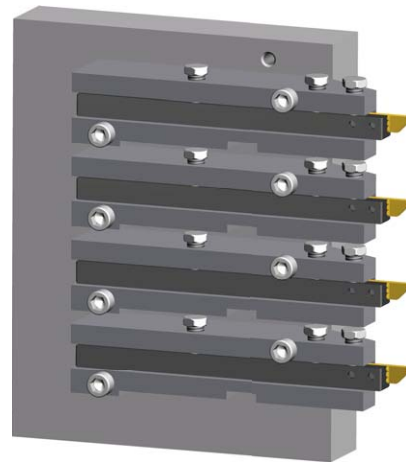

sans
ohne
without

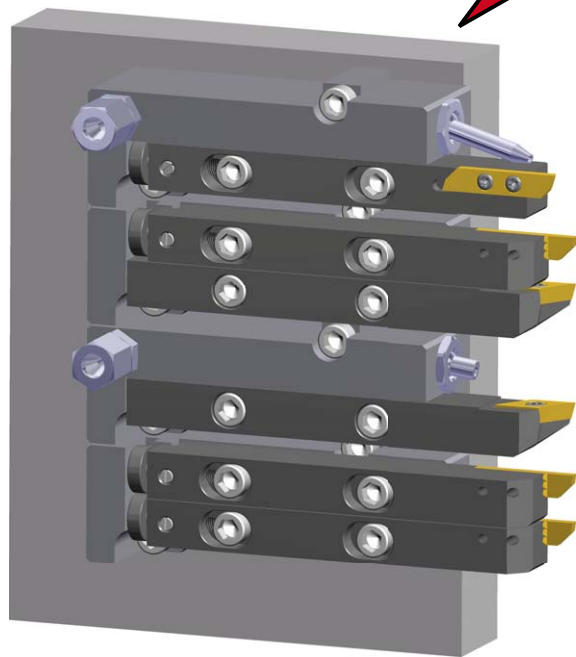

avec
mit
with

plus d'outils disponibles
höhere Werkzeuganzahl
more tools available



système d'arrosage efficace
effizientes Kühlmittelzufuhrsystem
efficient coolant supply system

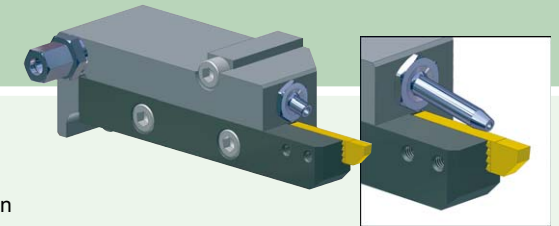

système compatible avec d'autres fabricants
Werkzeugsystem kompatibel mit anderen Lieferanten
standard system compatible with other suppliers

possibilité de pré réglage et de réglage de la longueur des outils
voreinstellbar auf feste oder einstellbare Länge
presetting on fixed or adjustable length



système de fixation robuste et rigide
robustes und starres Spannsystem
strong and stable clamping system

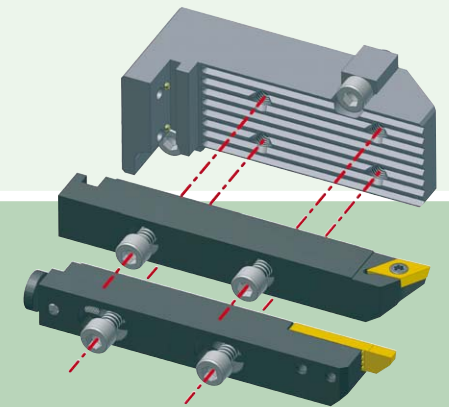





changement d'outil simple et rapide
einfacher und schneller Werkzeugwechsel
easy and quick tool replacement

Adaptations disponibles pour les machines suivantes
 Verfügbare Anpassungen für foldende Maschinen
 Adapters available for the following machines

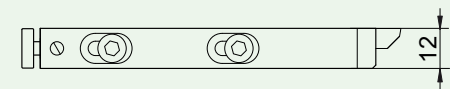
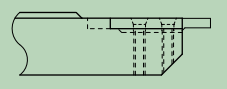
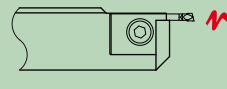
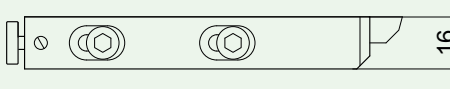
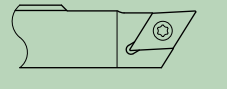
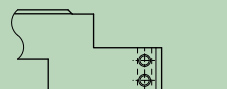
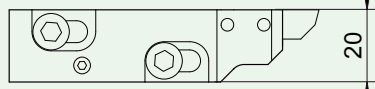
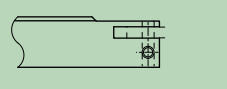
Fabricant Hersteller Manufacturer	Machine Maschine Machine	Type Typ Type	Page Seite Page
CITIZEN	C12 / C16	ML12	7.04
	K12 / K16 type VII	ML16	7.04
	L16 / L20 type VII / VIII	ML16	7.05
HANHWA	SL12 / 16 <i>new</i>	ML16	7.05
MANURHIN	KMX 426 / 526 / 626	ML16	7.06
	SWING 20 - 26 mm	ML16	7.06
STAR	SR-10J	ML12	7.07
	SA-12 / SA-16 / SA-16R	ML16	7.07
	SB-16	ML16	7.08
	SB-20C (E) <i>new</i>	ML16	7.08
	SR-16R / SR-20R / SR-20RII	ML16	7.09
	SR-20-RIII <i>new</i>	ML16	7.09
	SV12/20	ML16	7.10
TORNOS	DECO 7/10	ML12	7.11
	MICRO 7	ML12	7.15
	MICRO 8	ML12	7.15
	DECO 13	ML16	7.12
	DECO 20/26	ML16	7.13
	SIGMA 20/32	ML16	7.14
	DELTA 12/20 <i>new</i>	ML20	7.16
TSUGAMI	B012 <i>new</i>	ML20	7.16
	B020 <i>new</i>	ML20	7.16

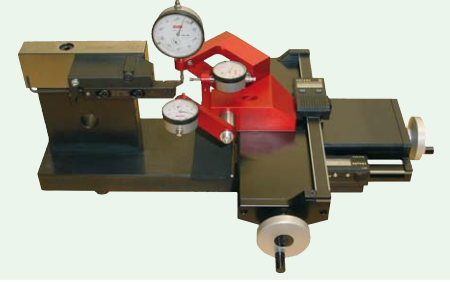
porte-outils
 Halter
 holder

Type	Section Querschnitt Section	Porte-outils Halter Holder	Page Seite Page
ML12			7.18-7.21
			7.18-7.21
ML16			7.19 7.21
			7.22
<i>new</i> ML20			7.22
OPTIONS	Modules d'arrosage et de serrage Kühlmitteldüse und Zufuhrelemente Coolant and clamping supply unit		7.23-7.24
	Banc de pré réglage Voreinstellgerät Presetting device		7.25
	Pièces de rechange / Ersatzteile / Spare parts		7.26-7.27

Type de machine Maschinen-Typ Type of machine	Désignation Bezeichnung Designation	Supports Halter 7.17-7.22 Holder	7.23 Accessoires Zubehör 7.23 Accessories	
			Module de serrage Spannelement Clamping unit	Module d'arrosage Kühlmittelzufuhrelement Coolant supply unit
C12/C16	ML12-CITIZEN-C16	ML12	ML12-FIX-12/14	ML12-JET-5/16

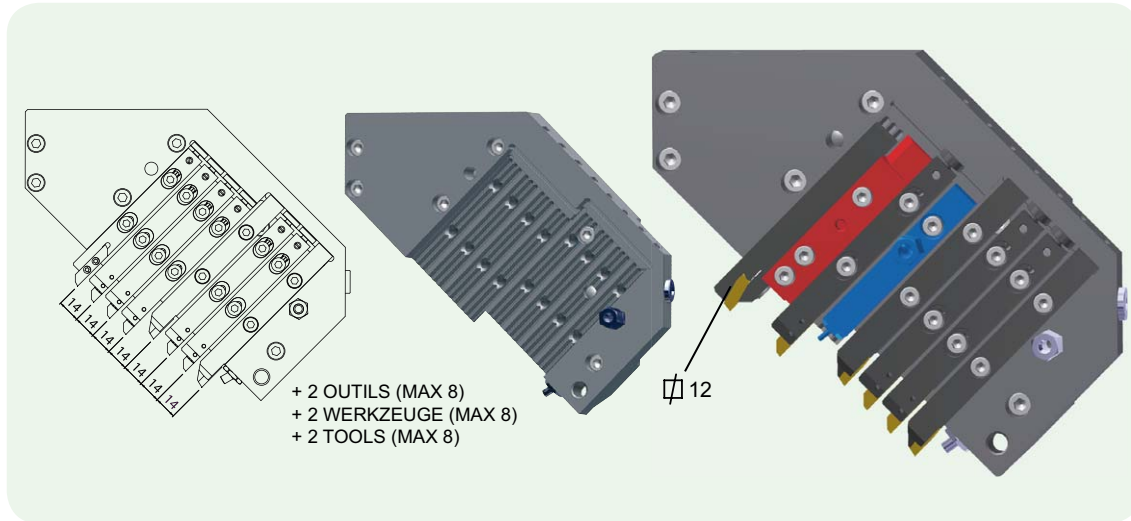

Type de machine Maschinen-Typ Type of machine	Désignation Bezeichnung Designation	Supports Halter 7.17-7.22 Holder	7.23 Accessoires Zubehör 7.23 Accessories	
			Module de serrage Spannelement Clamping unit	Module d'arrosage Kühlmittelzufuhrelement Coolant supply unit
K12 / K16 type VII	ML16-CITIZEN-K16	ML16	ML16-FIX-16/16.5	ML16-JET-7/16

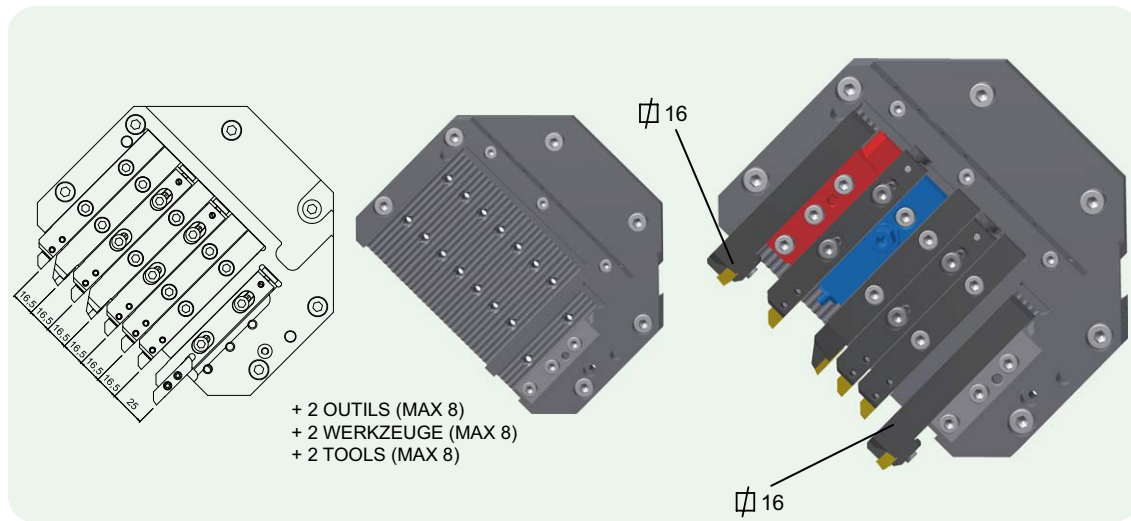

Type de machine Maschinen-Typ Type of machine	Désignation Bezeichnung Designation	Supports Halter 7.17-7.22 Holder	7.23 Accessoires Zubehör 7.23 Accessories	
			Module de serrage Spannelement Clamping unit	Module d'arrosage Kühlmittelzufuhrelement Coolant supply unit
L16 / L20 type VII / VIII	ML16-CITIZEN-L20	ML16	includ inbegriffen included	ML16-JET-7/16

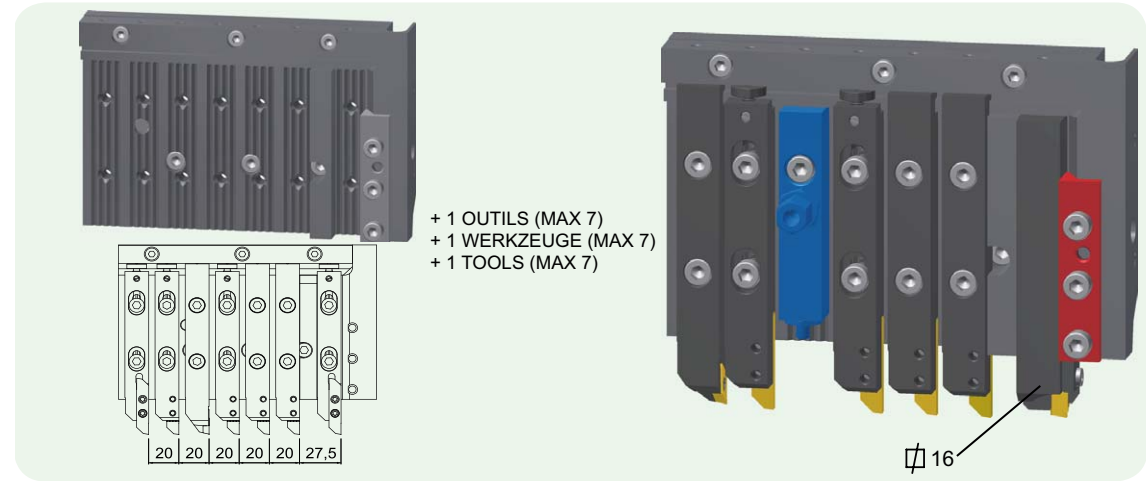

Type de machine Maschinen-Typ Type of machine	Désignation Bezeichnung Designation	Supports Halter 7.17-7.22 Holder	7.23 Accessoires Zubehör 7.23 Accessories	
			Module de serrage Spannelement Clamping unit	Module d'arrosage Kühlmittelzufuhrelement Coolant supply unit
SL12 / 16	ML16-HANHWA-SL12/16	ML16	-	ML16-JET-7/16



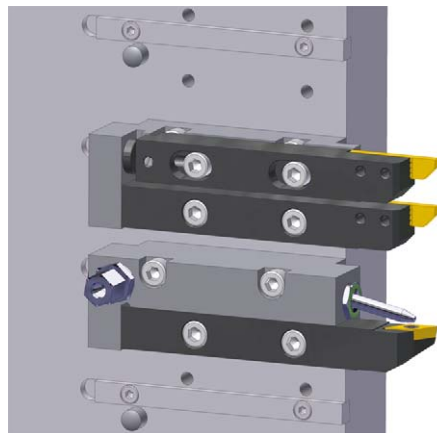

Type de machine Maschinen-Typ Type of machine	Désignation Bezeichnung Designation	Supports Halter Holder	Options d'arrosage Kühlmittelzufuhroptionen coolant nozzle options
KMX 426/526/626 SWING 20-26 mm	ML16-KMX26-JET	ML16	ML-JET-7/16...

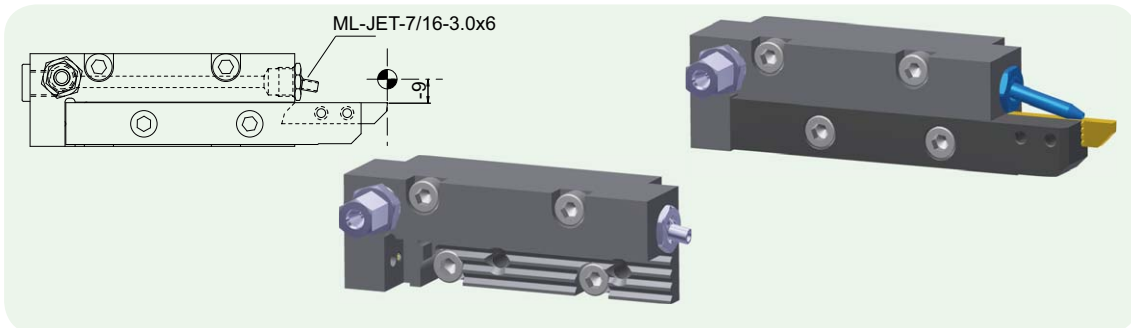

Type de machine Maschinen-Typ Type of machine	Désignation Bezeichnung Designation	Supports Halter Holder	Options d'arrosage Kühlmittelzufuhroptionen coolant nozzle options
KMX 426/526/626 SWING 20-26 mm	ML16-KMX26-DUO	ML16	-

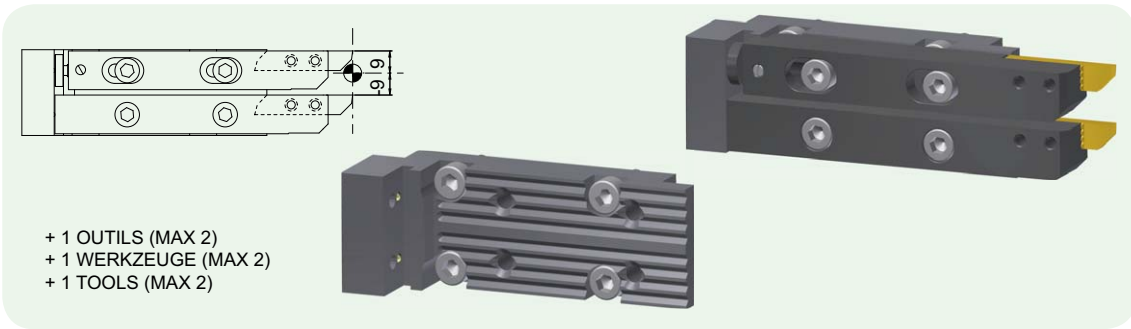

Type de machine Maschinen-Typ Type of machine	Désignation Bezeichnung Designation	Supports Halter Holder	Accessoires Zubehör Accessories
SR-10J	ML12-STAR-SR10J	ML12	7.23
			Module de serrage Spannelement Clamping unit <i>inclus inbegriffen included</i>
			Module d'arrosage Kühlmittelzufuhrelement Coolant supply unit ML12-JET-5/16

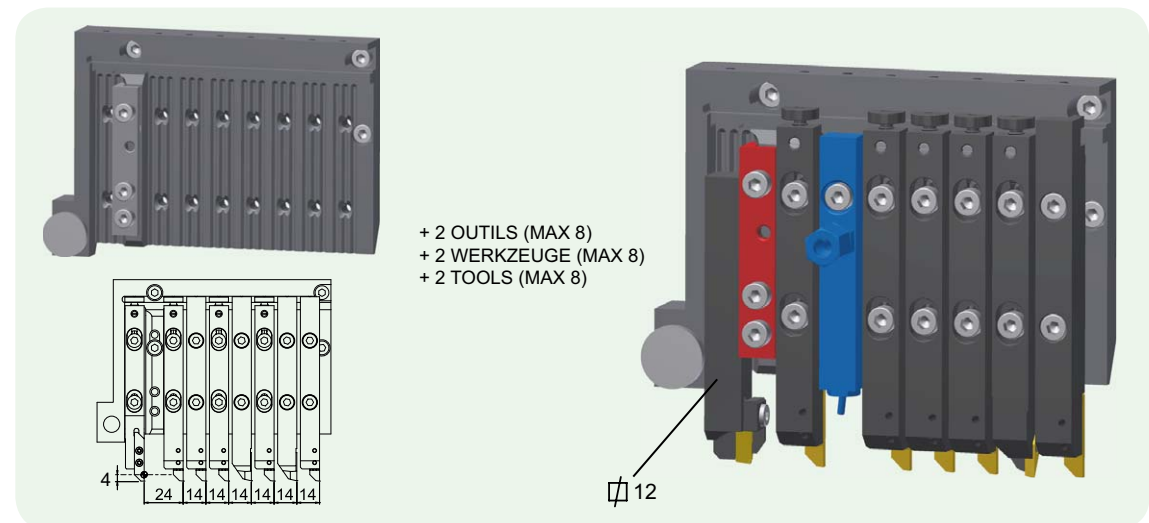

Type de machine Maschinen-Typ Type of machine	Désignation Bezeichnung Designation	Supports Halter Holder	Accessoires Zubehör Accessories
SA-12 SA-16 SA-16R	ML16-STAR-SA16	ML16	7.23
			Module de serrage Spannelement Clamping unit ML16-FIX-16/16
			Module d'arrosage Kühlmittelzufuhrelement Coolant supply unit ML16-JET-7/16

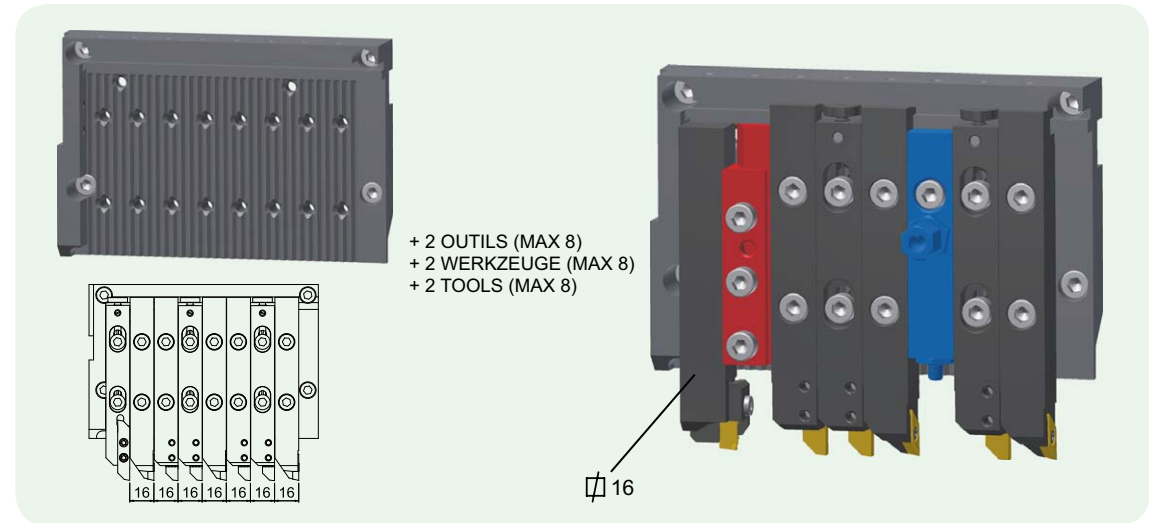

Type de machine Maschinen-Typ Type of machine	Désignation Bezeichnung Designation	Supports Halter 7.17-7.22 Holder	7.23 Accessoires Zubehör 7.23 Accessories	
			Module de serrage Spannelement Clamping unit	Module d'arrosage Kühlmittelzufuhrelement Coolant supply unit
SB-16	ML16-STAR-SB16	ML16	ML16-FIX-16/17	ML16-JET-7/16

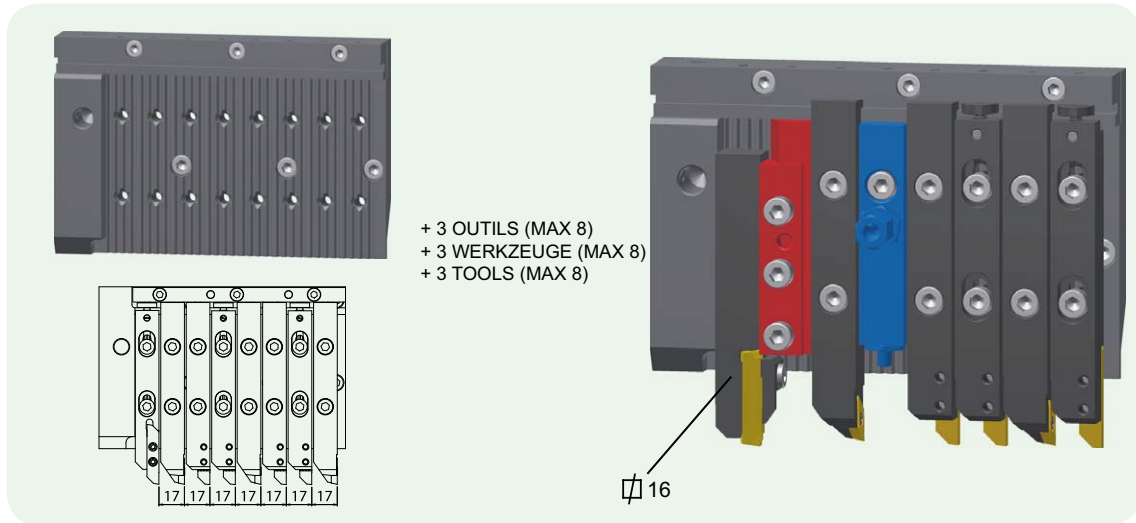

Type de machine Maschinen-Typ Type of machine	Désignation Bezeichnung Designation	Supports Halter 7.17-7.22 Holder	7.23 Accessoires Zubehör 7.23 Accessories	
			Module de serrage Spannelement Clamping unit	Module d'arrosage Kühlmittelzufuhrelement Coolant supply unit
SR-16R SR-20R SR-20RII	ML16-STAR-SR20	ML16	ML16-FIX-16/20	ML16-JET-7/16

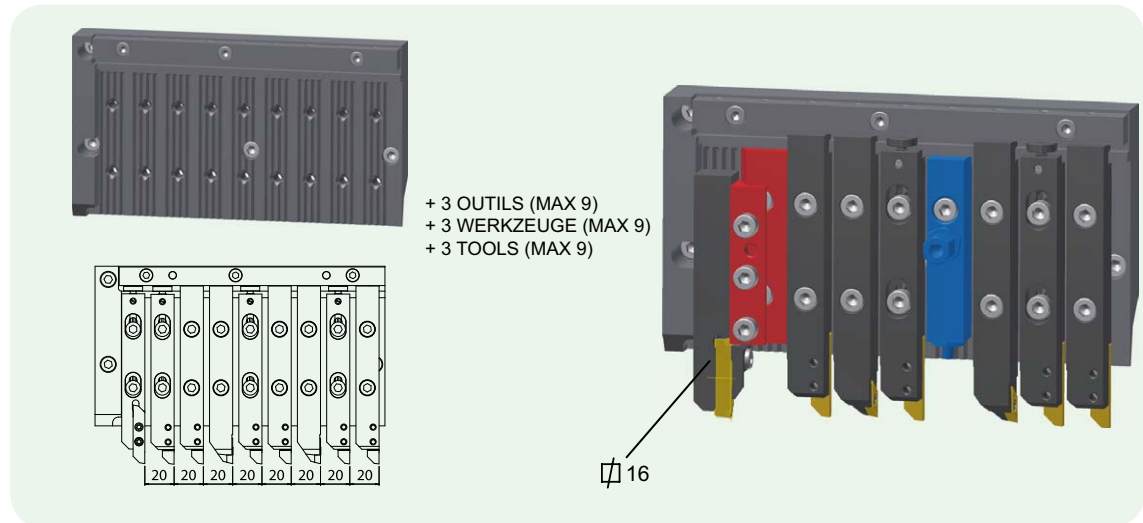

Type de machine Maschinen-Typ Type of machine	Désignation Bezeichnung Designation	Supports Halter 7.17-7.22 Holder	7.23 Accessoires Zubehör 7.23 Accessories	
			Module de serrage Spannelement Clamping unit	Module d'arrosage Kühlmittelzufuhrelement Coolant supply unit
SB-20C SB-20E	<i>new</i> ML16-STAR-SB20	ML16	ML16-FIX-16/22	ML16-JET-7/16

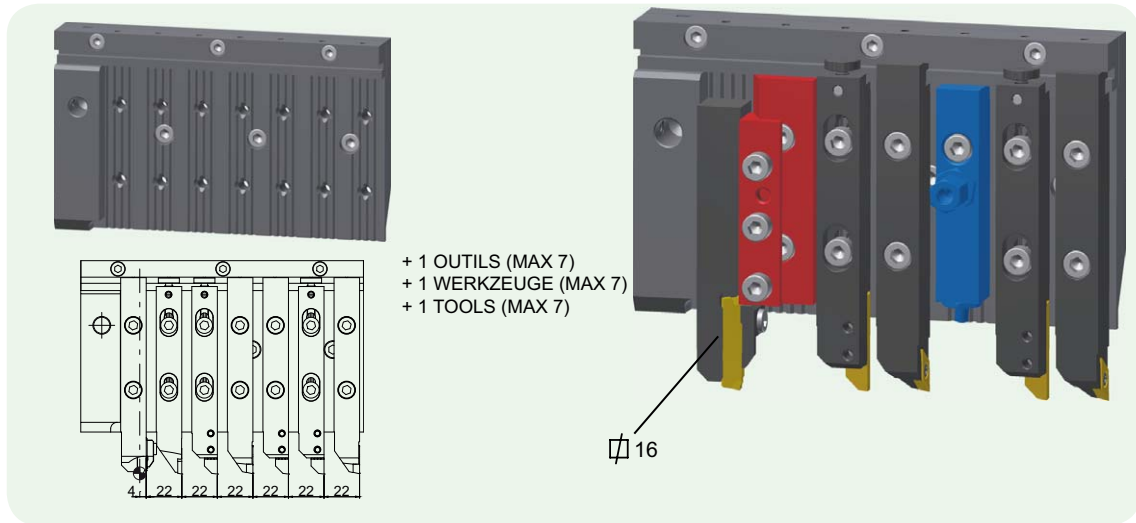

Type de machine Maschinen-Typ Type of machine	Désignation Bezeichnung Designation	Supports Halter 7.17-7.22 Holder	7.23 Accessoires Zubehör 7.23 Accessories	
			Module de serrage Spannelement Clamping unit	Module d'arrosage Kühlmittelzufuhrelement Coolant supply unit
SR-20RIII	<i>new</i> ML16-STAR-SR20RIII	ML16	ML16-FIX-16/20	ML16-JET-7/16

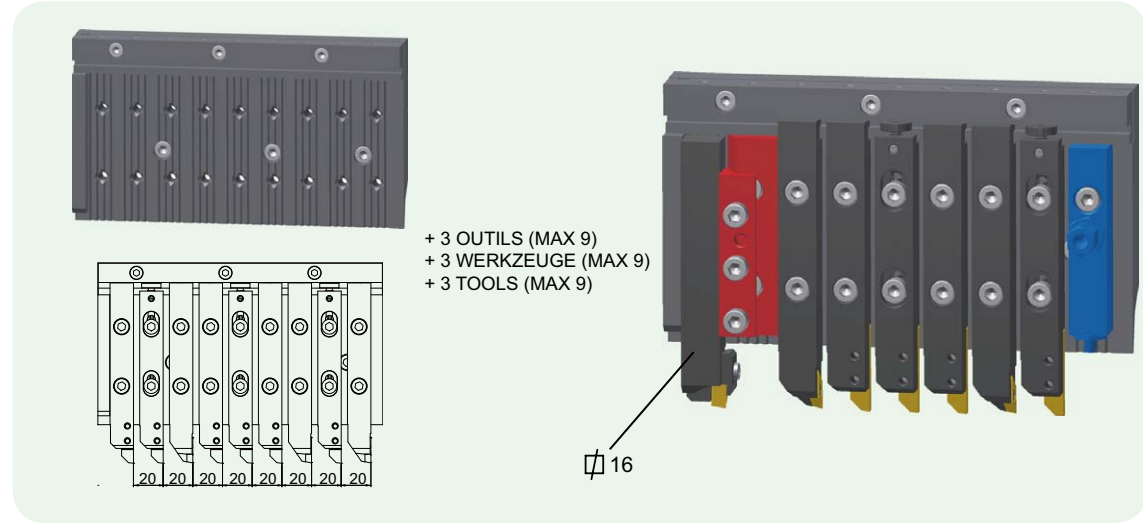

Type de machine Maschinen-Typ Type of machine	Désignation Bezeichnung Designation	Supports Halter Holder	7.17-7.22	7.23	Accessoires Zubehör Accessories	7.23
SV12/20	ML16-STAR-SV12/20	ML16		Module de serrage Spannelement Clamping unit	Module d'arrosage Kühlmitelzufuhrelement Coolant supply unit	
				ML16-FIX-16/20	ML16-JET-7/16	

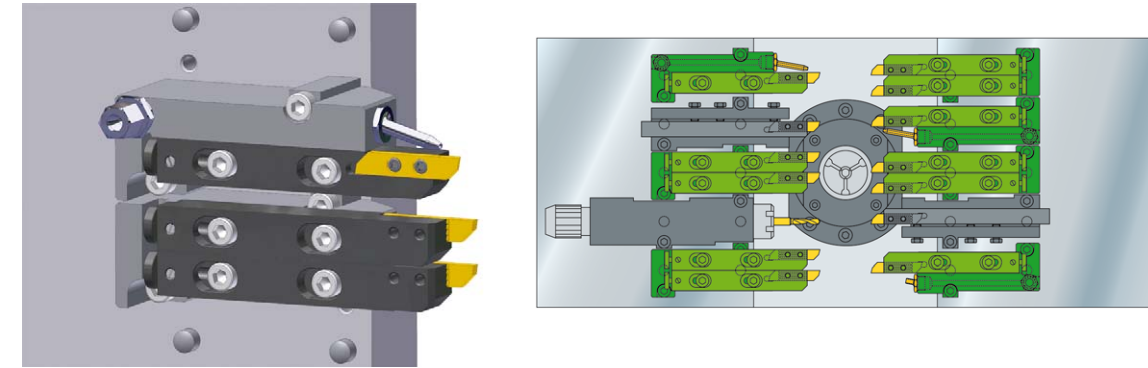
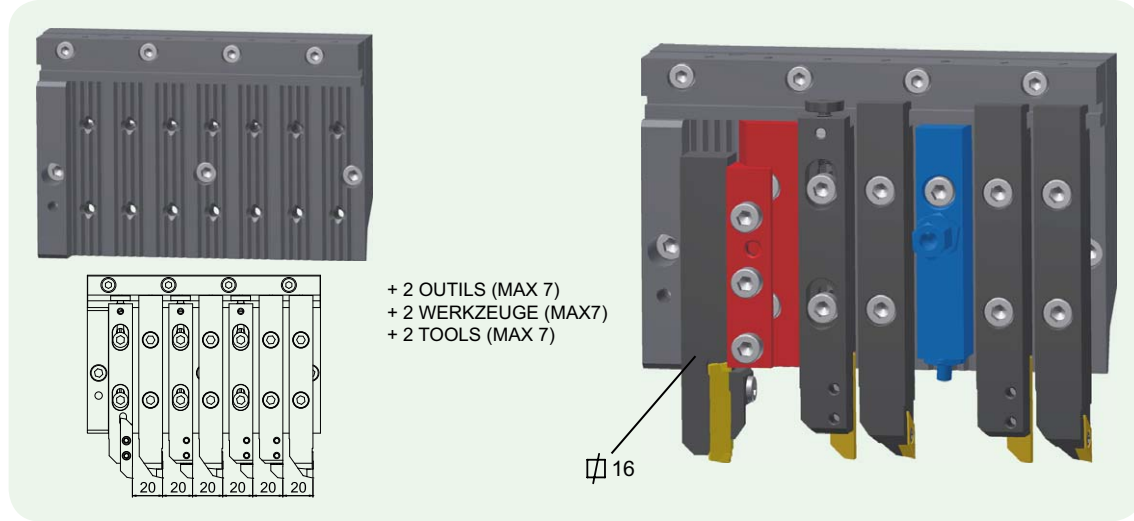

Type de machine Maschinen-Typ Type of machine	Désignation Bezeichnung Designation	Supports Halter Holder	7.17-7.22	Options d'arrosage Kühlmitelzufuhroptionen coolant nozzle options	7.24
DECO 7/10	ML12-DECO10-JET	ML12		ML-JET-7/16...	

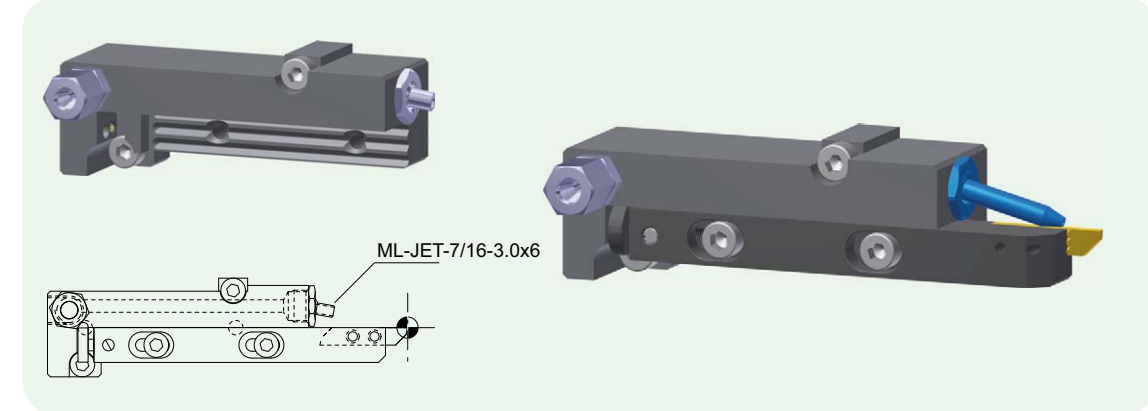

Type de machine Maschinen-Typ Type of machine	Désignation Bezeichnung Designation	Supports Halter Holder	7.17-7.22	Options d'arrosage Kühlmitelzufuhroptionen coolant nozzle options	-
DECO 7/10	ML12-DECO10-DUO	ML12			

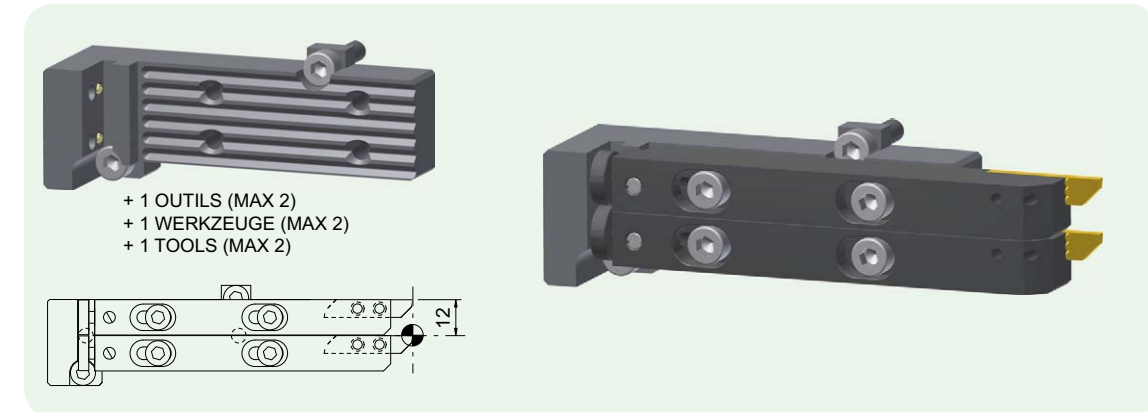

Type de machine Maschinen-Typ Type of machine	Désignation Bezeichnung Designation	Supports Halter Holder	Options d'arrosage Kühlmittelzufuhroptionen coolant nozzle options
DECO 13	ML16-DECO13-JET	7.17-7.22 ML16	7.24 ML-JET-7/16...

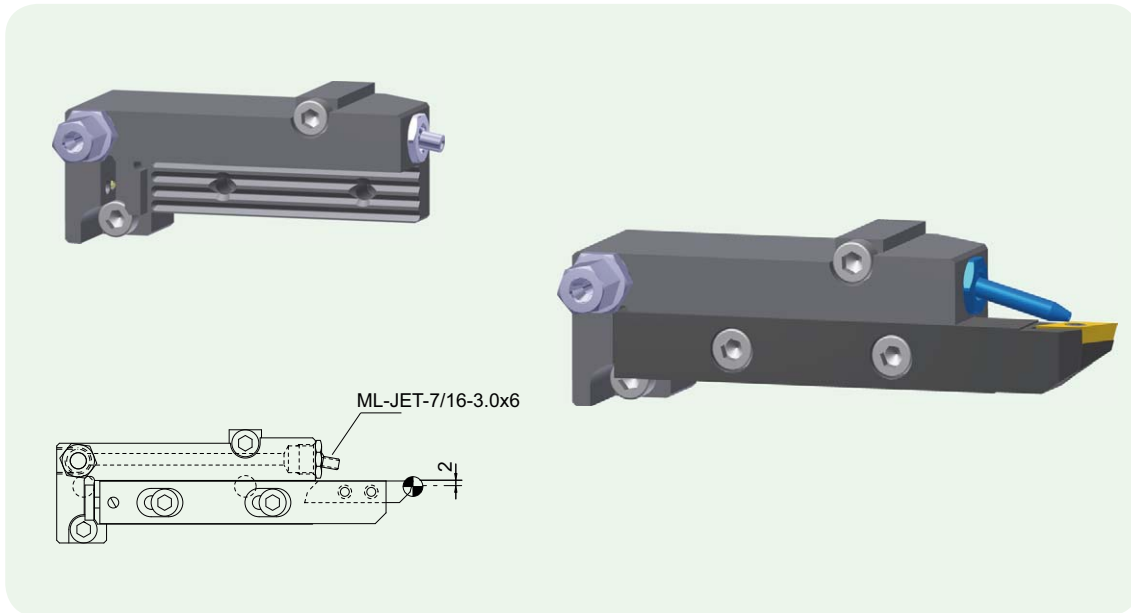

Type de machine Maschinen-Typ Type of machine	Désignation Bezeichnung Designation	Supports Halter Holder	Options d'arrosage Kühlmittelzufuhroptionen coolant nozzle options
DECO 13	ML16-DECO13-DUO	7.17-7.22 ML16	-

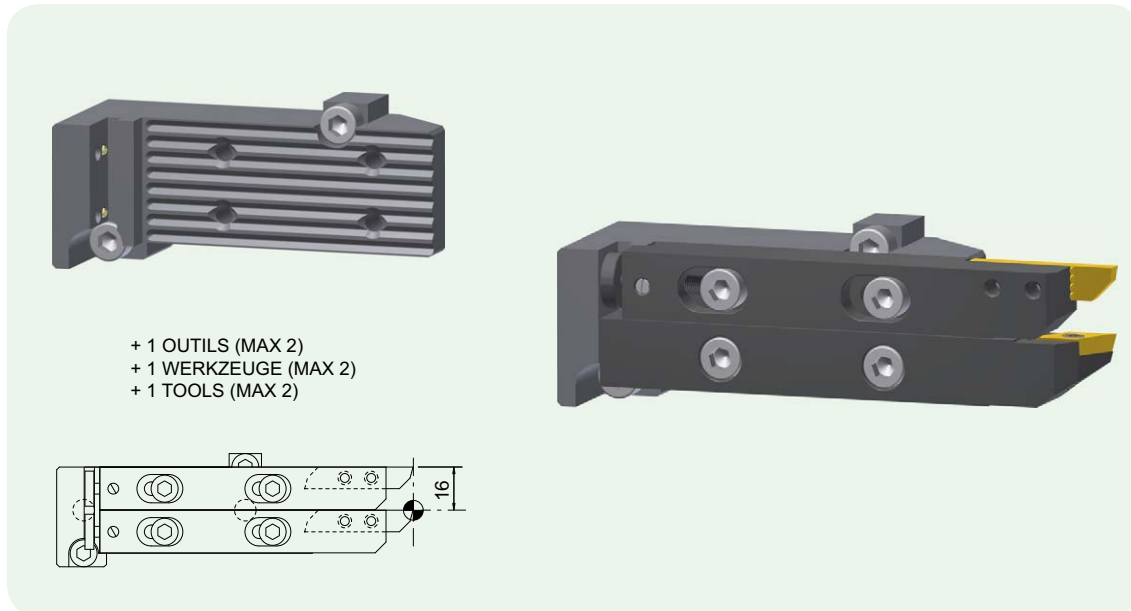

Type de machine Maschinen-Typ Type of machine	Désignation Bezeichnung Designation	Supports Halter Holder	Options d'arrosage Kühlmittelzufuhroptionen coolant nozzle options
DECO 20/26	ML16-DECO20-JET	7.17-7.22 ML16	7.24 ML-JET-7/16...

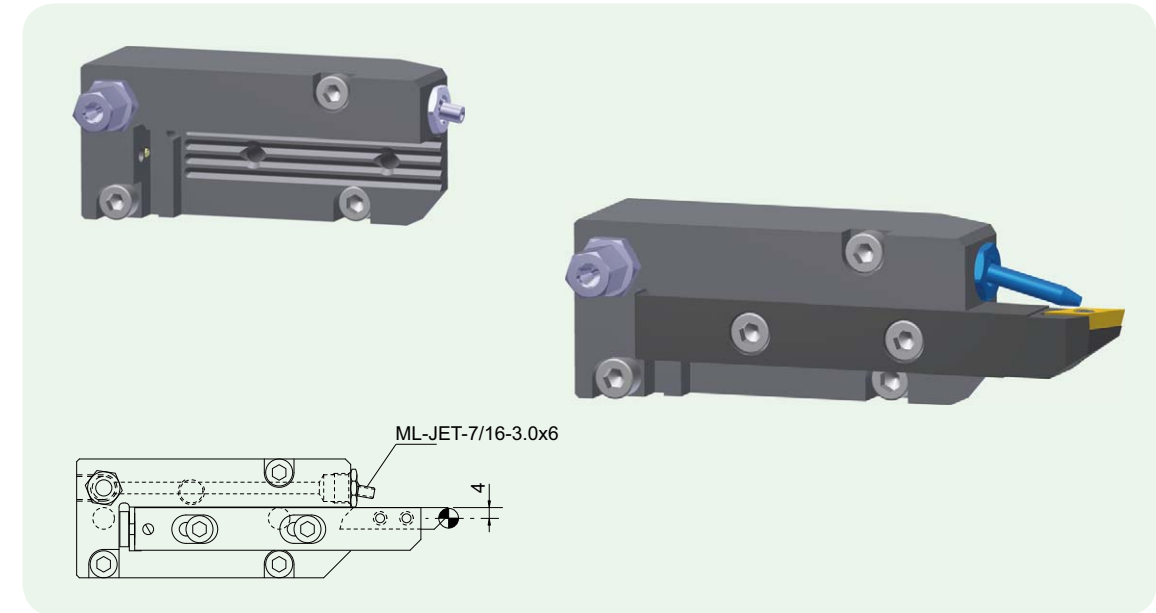

Type de machine Maschinen-Typ Type of machine	Désignation Bezeichnung Designation	Supports Halter Holder	Options d'arrosage Kühlmittelzufuhroptionen coolant nozzle options
DECO 20/26	ML16-DECO20-DUO	7.17-7.22 ML16	-

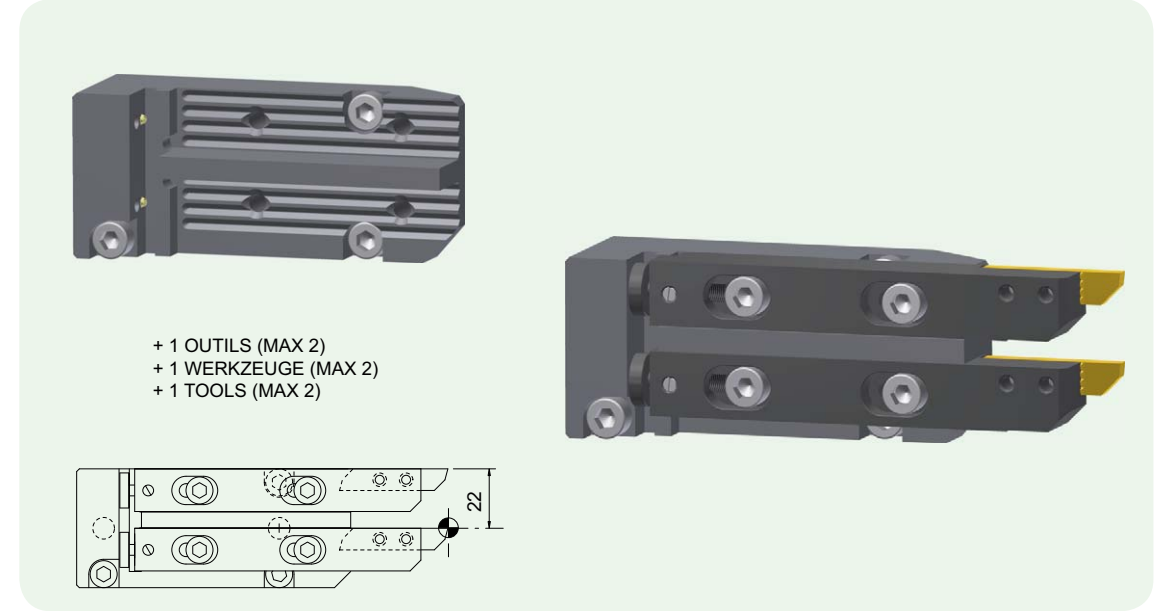

Type de machine Maschinen-Typ Type of machine	Désignation Bezeichnung Designation	Supports Halter 7.17-7.22 Holder	Options d'arrosage Kühlmittelzufuhroptionen coolant nozzle options 7.24
SIGMA 20/32	ML16-S20-JET	ML16	ML-JET-7/16...

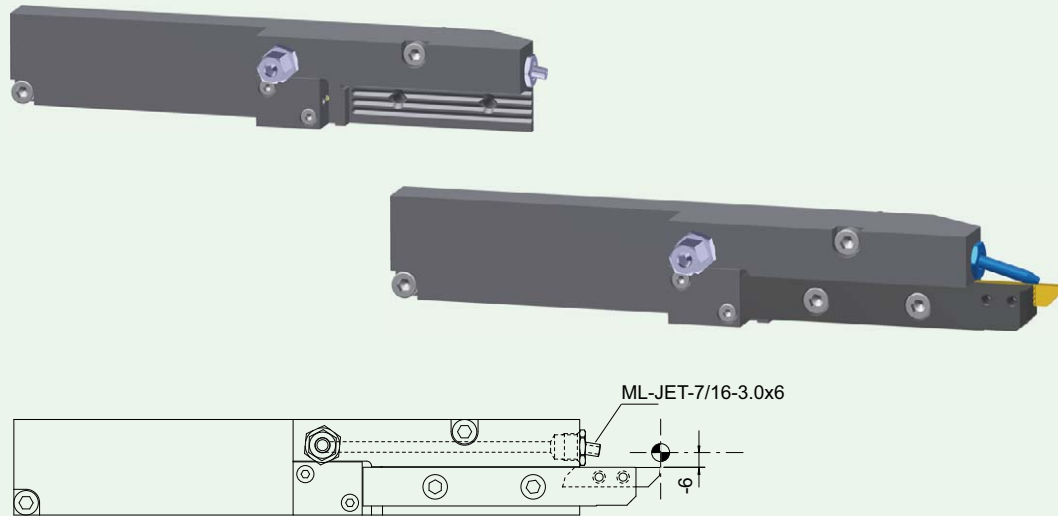

Type de machine Maschinen-Typ Type of machine	Désignation Bezeichnung Designation	Supports Halter 7.17-7.22 Holder	Options d'arrosage Kühlmittelzufuhroptionen coolant nozzle options
SIGMA 20/32	ML16-S20-DUO	ML16	-

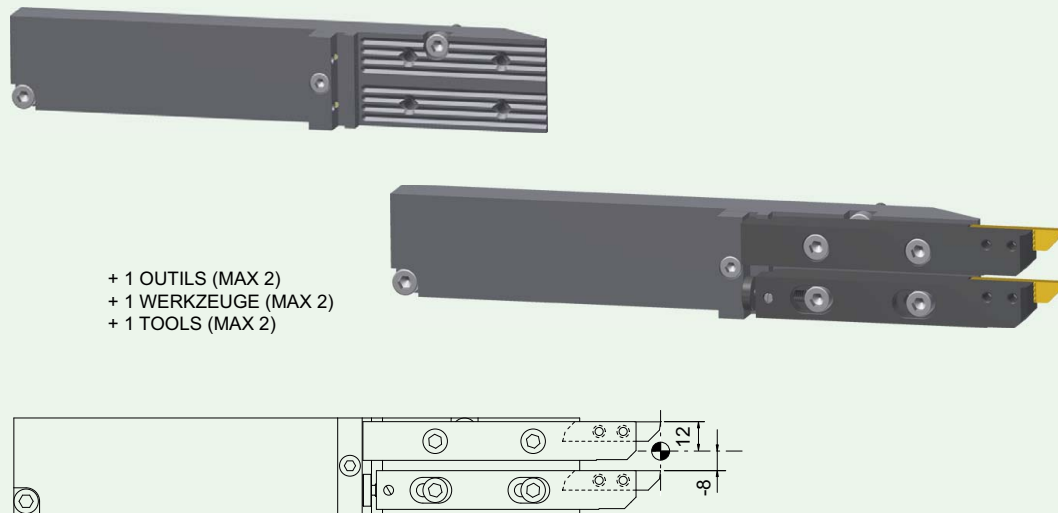

Type de machine Maschinen-Typ Type of machine	Désignation Bezeichnung Designation	Supports Halter 7.17-7.22 Holder	Accessoires Zubehör Accessories 7.23
MICRO 7	ML12-MICRO-7	ML12	Vis de serrage pour 1 outil Spannschrauben für 1 Halter \varnothing 12 Srew for 1 holder inclus inbegriffen included Module d'arrosage Kühlmittelzufuhrelement Coolant supply unit ML12-JET-5/16

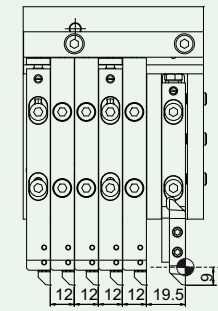

+ 2 OUTILS (MAX 8)
+ 2 WERKZEUGE (MAX 8)
+ 2 TOOLS (MAX 8)

outil de tronçonnage ML12a-750R-Micro7 fourni
 Abstechwerkzeug Typ ML12a-750R-Micro7 mitgeliefert
 Parting off tool type ML12a-750R-Micro7 included



Type de machine Maschinen-Typ Type of machine	Désignation Bezeichnung Designation	Supports Halter 7.17-7.22 Holder	Accessoires Zubehör Accessories 7.23
MICRO 8	ML12-MICRO-8	ML12	Module de serrage Spannelement Clamping unit inclus inbegriffen included Module d'arrosage Kühlmittelzufuhrelement Coolant supply unit ML12-JET-5/16

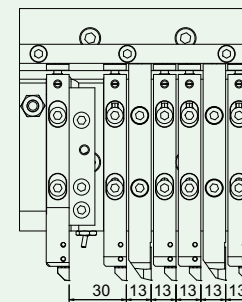

+ 2 OUTILS (MAX 8)
+ 2 WERKZEUGE (MAX 8)
+ 2 TOOLS (MAX 8)

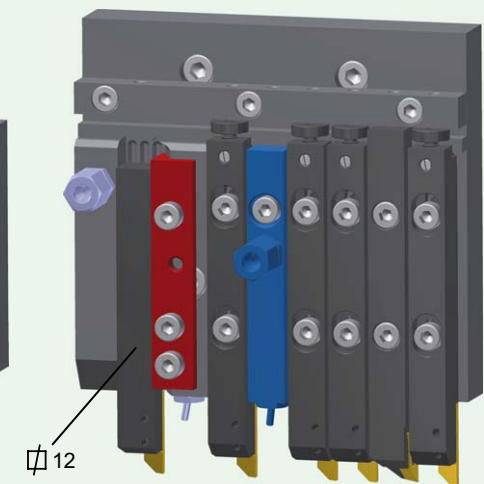

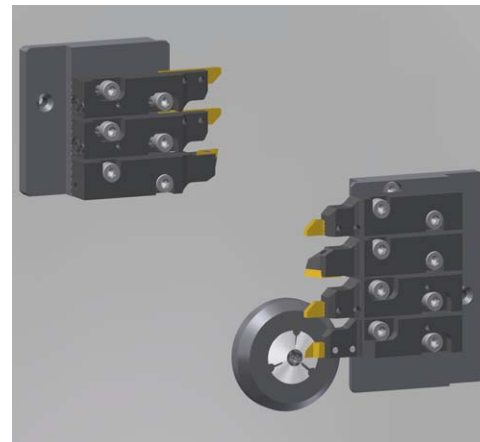
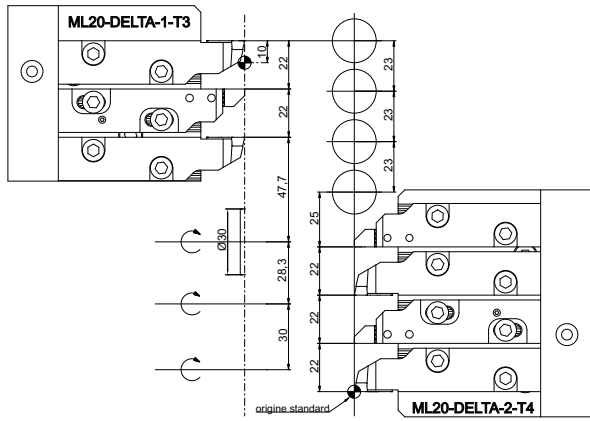

Type de machine Maschinen-Typ Type of machine	Désignation Bezeichnung Designation	Supports Halter Holder	Module d'arrosage Kühlmittelzufuhrelement Coolant supply unit
DELTA 12 / B012 DELTA 20 / B020	ML20-DELTA-1-T3	ML20	ML20-JET-7/16

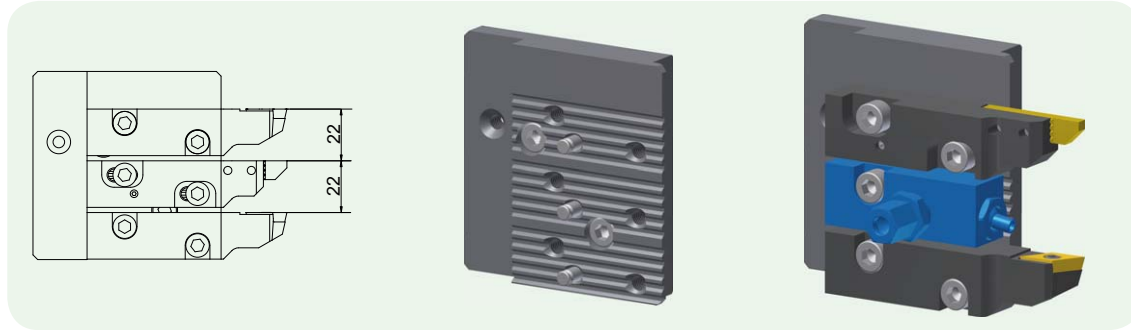

Type de machine Maschinen-Typ Type of machine	Désignation Bezeichnung Designation	Supports Halter Holder	Module d'arrosage Kühlmittelzufuhrelement Coolant supply unit
DELTA 12 / B012 DELTA 20 / B020	ML20-DELTA-2-T4	ML20	ML20-JET-7/16



Porte-plaquette
WSP-Halter
Insert holder

Système de fixation (fixe et réglable)
Befestigungssystem (Fixlänge und einstellbar)
Clamping system (fixed length and adjustable)

f = longueur fixe
Fixlänge
fixed length

a = réglable
einstellbar
adjustable

ML12

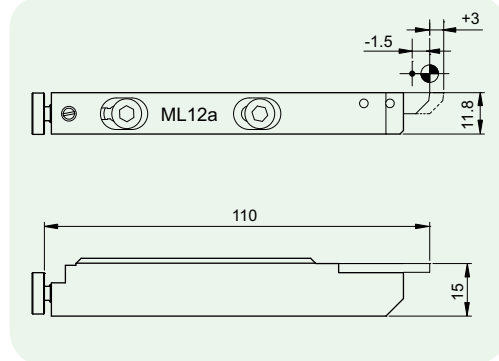
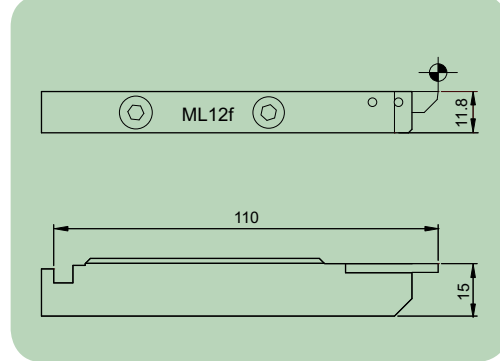

ML16

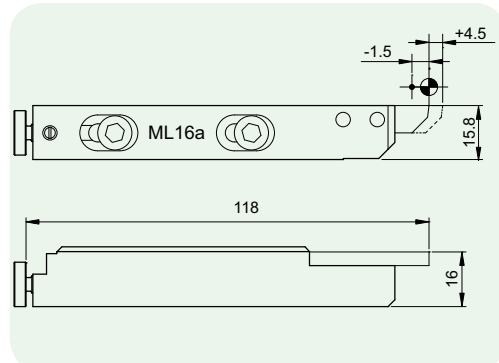
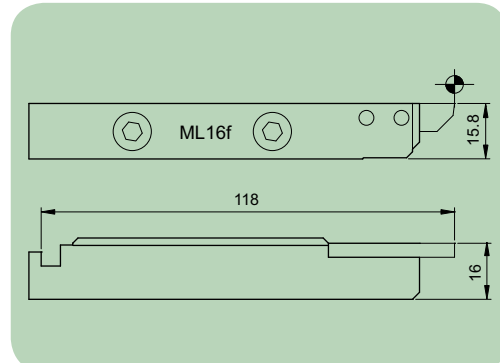

ML20

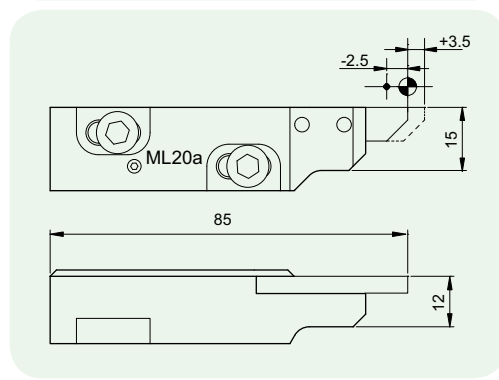
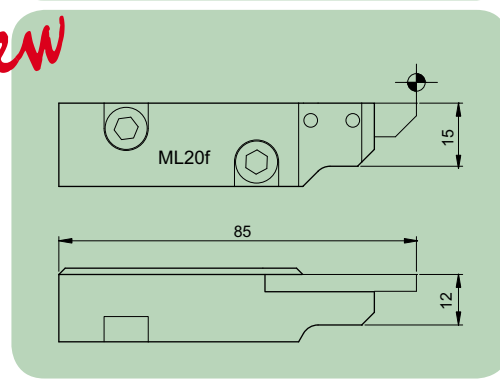

Porte-plaquette WSP-Halter Insert holder

	ML12	ML16	ML20	Pour plaquettes type... Für WSP-Type... For inserts type...	Page Seite Page
Art. N°	Art. N°	Art. N°			
	ML12a-340	ML16a-340	ML20a-340	TOP-LINE type 347 - 349	1.15 - 1.17
	ML12f-340	ML16f-340	ML20f-340		
	ML12a-740	ML16a-740	ML20a-740	TOP-LINE type 741 - 747	1.27 - 1.41
	ML12f-740	ML16f-740	ML20f-740		
	ML12a-740-C			TOP-LINE type 741 - 747	1.27 - 1.41
	ML12f-740-C				
	ML12a-760	ML16a-760	ML20a-760	TOP-LINE type 761 - 767	1.47 - 1.67
	ML12f-760	ML16f-760	ML20f-760		
		ML16a-760-C		TOP-LINE type 761 - 767	1.47 - 1.67
		ML16f-760-C			
			ML20a-760-C	TOP-LINE type 761 - 767	1.47 - 1.67
			ML20f-760-C		
	ML12a-CUT16	ML16a-CUT16		CUT-LINE type CUT16	2.06 - 2.07
	ML12f-CUT16	ML16f-CUT16			
			ML20a-CUT16	CUT-LINE type CUT16	2.06 - 2.07
	ML12a-CUT22	ML16a-CUT22		CUT-LINE type CUT22	2.06 - 2.09
	ML12f-CUT22	ML16f-CUT22			

300

700

CUT

Porte-plaquette WSP-Halter Insert holder

	ML12	ML16	ML20	Pour plaquettes type... Für WSP-Type... For inserts type...	Page Seite Page
Art. N°	Art. N°	Art. N°			
			ML20a-CUT22	CUT-LINE type CUT22	2.06 - 2.09
	ML12a-SCLCR06	ML16a-SCLCR06		ISO-LINE CC..-0602.. (type 11..)	3.12 - 3.13
	ML12f-SCLCR06	ML16f-SCLCR06			
	ML12a-SCLCR09	ML16a-SCLCR09	ML20a-SCLCR09	ISO-LINE CC..-09T3.. (type 12..)	3.12 - 3.13
	ML12f-SCLCR09	ML16f-SCLCR09	ML20f-SCLCR09		
	ML12a-SDJCR07	ML16a-SDJCR07		ISO-LINE DC..-0702.. (type 13..)	3.18 - 3.19
	ML12f-SDJCR07	ML16f-SDJCR07			
	ML12a-SDJCR11	ML16a-SDJCR11	ML20a-SDJCR11	ISO-LINE DC..-11T3.. (type 14..)	3.18 - 3.19
	ML12f-SDJCR11	ML16f-SDJCR11	ML20f-SDJCR11		
	ML12a-SDNCN11	ML16a-SDNCN11		ISO-LINE DC..-11T3.. (type 14..)	3.18 - 3.19
	ML12f-SDNCN11	ML16a-SDNCN11			
	ML12a-SVJCR11	ML16a-SVJCR11	ML20a-SVJCR11	ISO-LINE VC..-1103.. (type 16..)	3.23 - 3.25
	ML12f-SVJCR11	ML16f-SVJCR11	ML20f-SVJCR11		
	ML12a-SVVCN11	ML16a-SVVCN11		ISO-LINE VC..-1103.. (type 16..)	3.24 - 3.25
	ML12f-SVVCN11	ML16f-SVVCN11			
	ML12a-260	ML16a-260		ECO-LINE type 261 - 266	4.04 - 4.09
	ML12f-260	ML16f-260			

CUT

ISO

ECO

Porte-plaquette WSP-Halter Insert holder

coupe à droite déportée ou usinage à gauche sur contre-broche

rechtsschneidend versetzt oder linksschneidend auf Gegenspindel

right hand cut off line or left hand cutt on subspindle

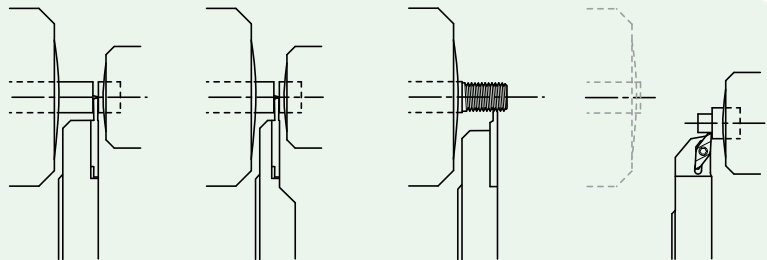

ML12	ML16	ML20	Pour plaquettes type... Für WSP-Type... For inserts type...	Page Seite Page
Art. N°	Art. N°	Art. N°		
	ML12a-330-V	ML16a-330-V	TOP-LINE type 337 - 339	1.14 1.16
	ML12a-730-V	ML16a-730-V	TOP-LINE type 731R 731-737	1.31 1.26 - 1.40
	ML12a-730-RC		TOP-LINE type 731R	1.31
	ML12a-750-V	ML16a-750-V	TOP-LINE type 751R 751-757	1.45/51/53 1.46 - 1.66
	ML16a-750-RC		TOP-LINE type 751R	1.45/51/53
	ML20a-750RC		TOP-LINE type 751R	1.45/51/53
	ML20a-CUT16RC		CUT-LINE type CUT16	2.06 2.07



300

700

CUT

Porte-plaquette WSP-Halter Insert holder

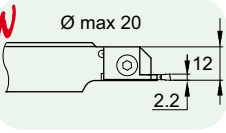
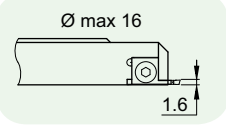
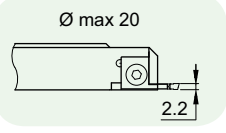
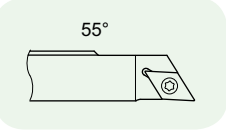
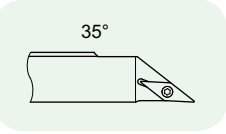
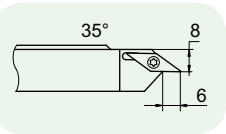
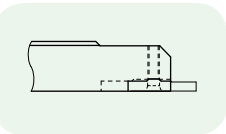
coupe à droite déportée ou usinage à gauche sur contre-broche
rechtsschneidend versetzt oder linksschneidend auf Gegenspindel
right hand cut off line or left hand cutt on subspindle

ML12	ML16	ML20	Pour plaquettes type... Für WSP-Type... For inserts type...	Page Seite Page
Art. N°	Art. N°	Art. N°		
		ML20a-CUT22RC	CUT-LINE type CUT 22	2.06 - 2.09
	ML12a-CUT16-V	ML16a-CUT16-V	CUT-LINE type CUT16	2.06 - 2.07
	ML12f-CUT16-V	ML16f-CUT16-V		
	ML12a-CUT22-V	ML16a-CUT22-V	CUT-LINE type CUT22	2.06 - 2.09
	ML12f-CUT22-V	ML16f-CUT22-V		
	ML12a-SDJCL11-V	ML16a-SDJCL11-V	ISO-LINE type DC...-11T3.. (type 14..)	3.18 - 3.19
	ML12a-SVJCL11-V	ML16a-SVJCL11-V	ISO-LINE type VC...-1103.. (type 16..)	3.23 - 3.25
	ML12a-SV-CR11	ML16a-SV-CR11	ISO-LINE type VC...-1103.. (type 16..)	3.23 - 3.25
	ML12a-250-V	ML16a-250-V	ECO-LINE type 251R 251-256	4.04 - 4.08

new
CUT

ISO

ECO

Porte-outils Werkzeughalter Tool holders

a = réglable
einstellbar
adjustable

L / R

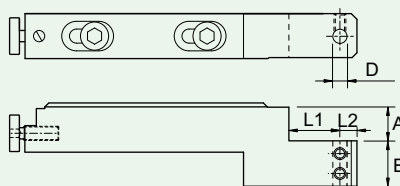

A	D	E	L1	L2	Art. N°
8	3	12	13	6	ML12a-2440-8-3
8	4	12	13	6	ML12a-2440-8-4
8	5	12	13	6	ML12a-2440-8-5
12	6	12	13	6	ML12a-2440-12-6
12	3	16	18	6	ML16a-2440-12-3
12	4	16	18	6	ML16a-2440-12-4
12	5	16	18	6	ML16a-2440-12-5
12	6	16	18	6	ML16a-2440-12-6
18	8	16	18	6	ML16a-2440-18-8

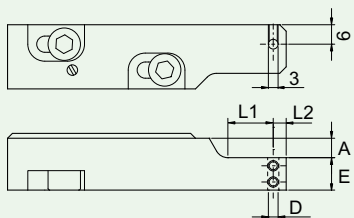

6	3	10	14	4	ML20a-2440-3-6
8	4	8	14	4	ML20a-2440-8-4

Porte-molettes Rändelhalter Knurl holders

a = réglable
einstellbar
adjustable

L / R

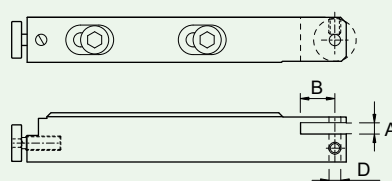

A	D	B	Art. N°
4	4	8	ML12a-2402-44

4	4	11	ML16a-2402-44
---	---	----	---------------

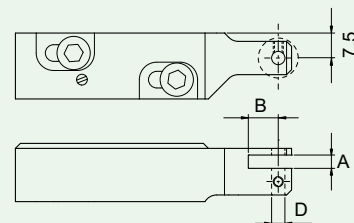

4	4	9	ML20a-2402-44
---	---	---	---------------

Module de serrage Spannelement Clamping unit

ML12

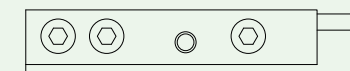

Art. N°
ML12-FIX-12/14

ML16



Art. N°
ML16-FIX-16/16
ML16-FIX-16/16.5
ML16-FIX-16/17
ML16-FIX-16/20
ML16-FIX-16/22

Module d'arrosage Kühlmitelzufuhrelement Coolant supply unit

ML12

Raccord
Anschluss
Connection

buse d'arrosage
Kühlmitteldüse
coolant nozzle

Ø 6 G1/8

5/16"
Ø 1.6 x 6

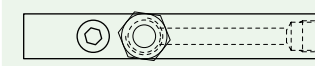

Art. N°
ML12-JET-5/16

ML16

Raccord
Anschluss
Connection

buse d'arrosage
Kühlmitteldüse
coolant nozzle

Ø 6 G1/8

7/16"
Ø 3 x 6

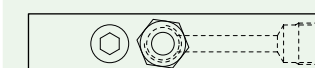

Art. N°
ML16-JET-7/16

ML20

Raccord
Anschluss
Connection

buse d'arrosage
Kühlmitteldüse
coolant nozzle

Ø 6 G1/8

7/16"
Ø 3 x 6



Art. N°
ML20-JET-7/16

Buse optionnelle voir page 7.24

Zusätzliche Düsen siehe Seite 7.24

Optional nozzle see page 7.24

buse d'arrosage
Kühlmitteldüse
coolant nozzle

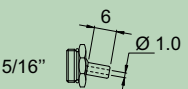
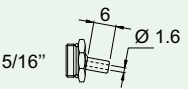
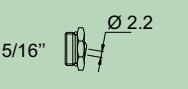
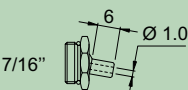
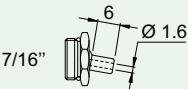
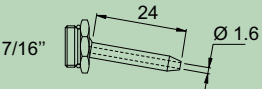
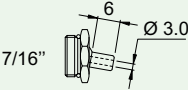
5/16"	Art. N°	références compatibles kompatible Artikeln compatible items
	ML-JET 5/16 1.0x6	<p>ML12-MICRO-8 ML12-JET-5/16</p> <p>une buse ML-JET 5/16 1.6x6 est comprise avec chacun de ces articles. eine Düse ML-JET 5/16 1.6x6 ist mit jedem Artikel inbegriffen. a nozzle ML-JET 5/16 1.6x6 is included with each item.</p>
	ML-JET 5/16 1.6x6	
	ML-JET 5/16 2.2x0	
7/16"	Art. N°	références compatibles kompatible Artikeln compatible items
	ML-JET 7/16 1.0x6	<p>ML12-CITIZEN-C16 ML12-DECO10-JET ML16-DECO13-JET ML16-DECO20-JET ML16-S20-JET ML16-KMX26-JET ML16-JET-7/16 ML20-JET-7/16</p> <p>une buse ML-JET 7/16 3.0x6 est comprise avec chacun de ces articles. eine Düse ML-JET 7/16 3.0x6 ist mit jedem Artikel inbegriffen. a nozzle ML-JET 7/16 3.0x6 is included with each item.</p>
	ML-JET 7/16 1.6x6	
	ML-JET 7/16 1.6x24	
	ML-JET 7/16 3.0x6	

Banc de pré réglage
Voreinstellgerät
Presetting device

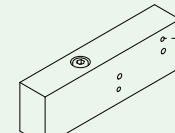
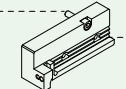
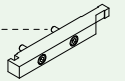
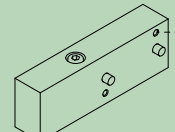
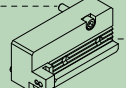
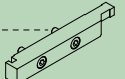
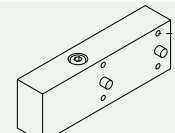
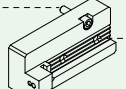
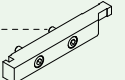
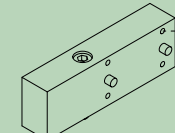
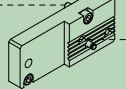
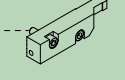

Type Typ Type	Machine Maschine Machine	Adaptateur et jauge d'étalonnage Adapter und Einstelllehre Adaptor and master gauge
ML12	CITIZEN C12 / C16 STAR SR-10J TORNOS DECO 7/10 TORNOS MICRO 7 TORNOS MICRO 8	 ML12-AD1  ML12-AD2  ML12-MASTER
	CITIZEN K12 / K16 type VII CITIZEN L16 / L20 type VII / VIII HANHWA SL12 / 16 MANURHIN KMX 426 / 526 / 626 MANURHIN SWING 20 - 26 mm STAR SA-12 / SA-16 / SA-16R STAR SB-16 STAR SB-20C (E) STAR SR-16R STAR SR-20R / SR-20RII / SR-20-RIII STAR SV12 / 20 TORNOS DECO 20 / 26 TORNOS DECO SIGMA 20	 ML16/20-AD1  ML16-AD2  ML16-MASTER
ML16	TORNOS DECO 13	 ML16-DECO13-AD1  ML16-DECO13-AD2  ML16-MASTER
	TORNOS DELTA 12 / 20 TSUGAMI B012 / B020	 ML16/20-AD1  ML20-AD2  ML20-MASTER
ML20		

pièces de rechange
Ersatzteile
spare parts

ML12

vis de réglage
Einstellungsschraube
setting screw

vis de blocage
Blockierschraube
locking screw

vis de fixation
Befestigungsschraube
fixing screw

Art. N°
ML12a-M5x0.5

Art. N°
ML-M4x4-T

Art. N°
ML12-M5xL20

ML16

vis de réglage
Einstellungsschraube
setting screw

vis de blocage
Blockierschraube
locking screw

vis de fixation
Befestigungsschraube
fixing screw

Art. N°
ML16a-M5x0.5

Art. N°
ML-M4x4-T

Art. N°
ML16/20-M6xL20

ML20

vis de fixation
Befestigungsschraube
fixing screw

Art. N°
ML16/20-M6xL20

pièces de rechange
Ersatzteile
spare parts

vis et clés pour le serrage des plaquettes
Schrauben und Schlüssel für WSP-Befestigung
screws and keys for insert clamping

porte-outils Halter holders			
ML...-250	V-M4x9-T15	T15	
ML...-260	V-M4x9-T15	T15	
ML...-330	V-M2.5x7.8-T8	T8	
ML...-340	V-M2.5x7.8-T8	T8	
ML...-730	V-M3x7-T8	T8	
ML...-730RC	V-M3x5.5-T8	T8	
ML...-740	V-M3x7-T8	T8	
ML...-750	V-M4x9-T15	T15	
ML...-750RC	V-M4x7.3-T15	T15	
ML...-760	V-M4x9-T15	T15	
ML...-SC...06	V-M2.5x7.8-T8	T8	
ML...-SC...09	V-M4x9-T15-ISO	T15	
ML...-SD...07	V-M2.5x7.8-T8	T8	
ML...-SD...11	V-M4x9-T15-ISO	T15	
ML...-SV...11	V-M2.5x7.8-T8	T8	
ML12 / ML16...-CUT16	-	-	CUT16-RS-SET
ML20...-CUT16	-	-	CUT16-R-SET
ML20...-CUT16-RC	-	-	CUT16-L-SET
ML12 / ML16...-CUT16-V	-	-	CUT16-LS-SET
ML12 / ML16...-CUT22	-	-	CUT22-RS-SET
ML20...-CUT22	-	-	CUT22-R-SET
ML20...-CUT22-RC	-	-	CUT22-L-SET
ML12 / ML16...-CUT22-V	-	-	CUT22-LS-SET

pièces de rechange pour plaque de base
Ersatzteile für Grundplatte
spare parts for ground base

Art. N°
ML-205004

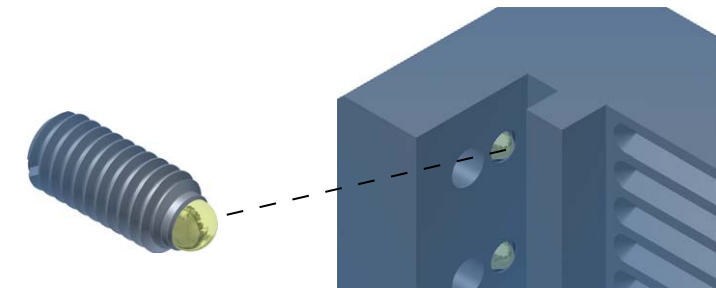

INDEX

Répertoire des articles
Artikelverzeichnis
Index of items

1005	6.10	261-E	4.03	339	1.16	736	1.40
1006	6.12	261L	4.04	342	1.15	737	1.40
1010	6.09	262	4.07	343	1.15	740	1.25
1101	5.04	2620	6.17	3431	6.21	740-C	1.25
1102	5.05	263	4.07	344	1.15	740/730-D	1.24
1103	5.06-07	2630	6.17	3441	6.21	740-DECO10	1.79
1107	6.24	264	4.09	345	1.15	740L-DECO10	1.76
1200	6.04	266	4.09	346	1.15	<i>new</i> 740-NOVIBRA	1.87
1400-J	6.26	2680	6.07	347	1.17	740Z	1.88
1401-K	6.26	2810	5.08	347-EN	1.15	741	1.27 / 1.29
1402	6.25	2815	5.08	348	1.17	741L	1.30
1420	6.26	2820	5.09	349	1.17	<i>new</i> 741SF	1.85
1450	6.28			3801	6.23	742	1.33
1460	6.28	311	1.10	3802	6.23	<i>new</i> 742SF	1.85
1500	6.04	312	1.10	3803	6.23	743	1.33 / 1.35
1510	6.04	313	1.10	3812	6.23	<i>new</i> 743SF	1.85
1600	6.16	314	1.10	3813	6.23	744	1.37 / 1.39
1610	6.16	315	1.10	3821	6.23	<i>new</i> 744ZX	1.39
1680	6.06	316	1.10	3822	6.23	<i>new</i> 745	1.39
1820	5.09	317	1.12	3831	6.23	746	1.41
1901	6.16	318	1.12	3832	6.23	747	1.41
		319	1.12	3833	6.23	750	1.42
2000	6.14	321	1.11	3834	6.23	750RAS	1.45
2001	6.15	322	1.11	3835	6.23	750RC	1.45
2005	6.11	323	1.11	3901	6.17	750R-DECO10	1.81
2006	6.13	3231	6.21	3911	6.17	751	1.46 / 1.48
2010	6.09	3238	6.21			751-E	1.46
2012	6.08	324	1.11	7050	1.72	751NXF	1.48 / 1.53
2013	6.08	325	1.11	7051	1.72	751R	1.51 / 1.53
2014	6.08	326	1.11	7051R	1.75	751RAS	1.45
2100	6.18	327	1.13	7060	1.73	751RD	1.45 / 1.81
2200	6.05	3271	6.19	7061	1.73	751RS	1.51 / 1.81
2400-J	6.27	3274	6.19	7061L	1.74	752	1.54
2401-K	6.27	3278	6.20	710	1.18	753	1.54/56/58
2402	6.25	3279	6.20	<i>new</i> 710-NOVIBRA	1.87	<i>new</i> 753ZX	1.58
2405	6.28	328	1.13	711	1.18	754	1.60 / 1.62
2420	6.27	3281	6.22	<i>new</i> 711SF	1.86	<i>new</i> 754ZX	1.62
2425	6.28	3282	6.22	712	1.20	756	1.64
2435	6.31	3283	6.22	<i>new</i> 712SF	1.86	757	1.66
2436	6.31	329	1.13	713	1.20	<i>new</i> 757ZX	1.66
2440	6.30	332	1.14	<i>new</i> 713SF	1.86	760	1.43
2441	6.30	333	1.14	714	1.22	760/750	1.42 / 1.43
2450	6.29	3331	6.21	716	1.22	760/750-D	1.44
2460	6.29	3335	6.20	720	1.19	760LC	1.44
2470	6.29	3336	6.21	721	1.19	760L-DECO10	1.80
2490	6.30	3337	6.21	722	1.21	760Z	1.88
250	4.02	3338	6.21	723	1.21	761	1.47 / 1.49
<i>new</i> 250-260F	4.02	334	1.14	724	1.23	761-E	1.47
250RC	4.03	3341	6.21	726	1.23	761L	1.50 / 1.52
251	4.04	335	1.14	730	1.24	761LD	1.80
251-E	4.02	336	1.14	730-DECO10	1.78	761LS	1.50 / 1.80
251R	4.05	3361	6.21	<i>new</i> 730-NOVIBRA	1.87	761NXF	1.49 / 1.52
252	4.06	337	1.16	730RC	1.25	762	1.55
2520	6.05	337-EN	1.14	730R-DECO10	1.79	763	1.55/57/59
253	4.06	3371	6.19	731	1.26 / 1.28	<i>new</i> 763ZX	1.59
2530	6.05	3374	6.19	731R	1.31	764	1.61 / 1.63
254	4.08	338	1.16	732	1.32	<i>new</i> 764ZX	1.63
256	4.08	3381	6.22	733	1.32 / 1.34	766	1.65
260	4.03	3382	6.22	734	1.36 / 1.38	767	1.67
260/250-D	4.02	3383	6.22	<i>new</i> 734ZX	1.38	<i>new</i> 767ZX	1.67
261	4.05	<i>new</i> 3384	6.23	<i>new</i> 735	1.38	770	1.68 / 1.83

INDEX

Répertoire des articles
Artikelverzeichnis
Index of items

770R-DECO13	1.82	ML16-STAR	7.07 - 7.10
770R-DECO20	1.82	<i>new</i> ML20a	7.18 - 7.21
771	1.68	<i>new</i> ML20-DELTA	7.16
771R	1.71	<i>new</i> ML20f	7.18 - 7.19
780	1.69	<i>new</i> ML20-AD2	7.25
781	1.69	<i>new</i> ML20-MASTER	7.25
781L	1.70	<i>new</i> ML20-JET	7.23
		<i>new</i> ML-JET	7.24
CC...	3.12 - 3.13	ML-PRESET-1	7.25
CUT16H	2.04		
CUT16HX	2.05	S8-0808	1.83
CUT22H	2.04	S8-730	1.83
CUT22HX	2.05	S8-740	1.83
CUT31H	2.04	SC...	3.10 - 3.11
CUT31HX	2.05	SD...	3.14 - 3.17
CUT-GN	2.09	SV...	3.20 - 3.22
<i>new</i> CUT-TN	2.08		
CUT-UN	2.06	THOR	6.14 - 6.15
CUT-UL	2.07		
CUT-UR	2.07	VC...	3.23 - 3.25
D16-L55	1.83	W750	1.76
D16-L50F-ER11	1.83	W751	1.76
DC...	3.18 - 3.19	W760	1.77
		W761	1.77
		WINNER	6.10 - 6.13
ISO-11..	3.12 - 3.13		
ISO-12..	3.12 - 3.13		
ISO-13..	3.18 - 3.19		
ISO-14..	3.18 - 3.19		
ISO-16..	3.23 - 3.25		
ISO-17..	3.24 - 3.25		
ISO-21..	3.10 - 3.11		
ISO-22..	3.10 - 3.11		
ISO-23..	3.14 - 3.17		
ISO-24..	3.14 - 3.17		
ISO-26..	3.20 - 3.22		
ISO-27..	3.20 - 3.21		
ML12a	7.18 - 7.22		
ML12a-750R-Micro7	7.15		
ML12-AD	7.25		
ML12-CITIZEN	7.04		
ML12-DECO	7.11		
ML12f	7.18 - 7.21		
ML12-FIX	7.23		
ML12-JET	7.23		
ML12-MASTER	7.25		
ML12-MICRO	7.15		
ML12-STAR-SR10J	7.07		
ML16a	7.18 - 7.22		
ML16/20-AD	7.25		
ML16-DECO13-AD	7.25		
ML16-CITIZEN	7.04 - 7.05		
ML16-DECO	7.12 - 7.13		
ML16-f	7.18 - 7.21		
ML16-FIX	7.23		
ML16-HANHWA	7.05		
<i>new</i> ML16-JET	7.23		
ML16-KMX26	7.06		
ML16-MASTER	7.25		
ML16-S20	7.14		

Outils spécifiques pour machines :	
Sonderwerkzeuge für Maschine :	
Special tools for machines :	
Citizen-Cincom	7.04 - 7.05
Hanhwa	7.05
Manurhin	7.06
Star	7.07 - 7.10
Tornos Deco	1.78-82/6.31/7.11-7.13
<i>new</i> Tornos Delta	7.16
Tornos Micro	1.83 / 7.15
Tornos Sigma	7.14
<i>new</i> Tsugami	7.16