



### Features

- Up to 95% Efficiency
- Current Mode Operation for Excellent Line and Load Transient Response
- Low Quiescent Current: 200μA
- Output Voltage: 0.6V~5.5V
- Automatic PWM/PFM Mode Switching
- No Schottky Diode Required
- 1.2MHz Constant Frequency Operation
- Short-Circuit Protection
- Shutdown Quiescent Current: < 1μA
- Low Profile SOT-23-5L Package (lead-free packaging is now available)

### Applications

- Digital cameras and MP3
- Palmtop computers / PDAs
- Cellular phones
- PC cards
- Portable media players

### Description

The HX1002 is high efficiency synchronous, PWM step-down DC/DC converters working under an input voltage range from 2.5V to 5.5V. This feature makes the HX1002 suitable for single Li-Lon battery-powered applications. 100% duty cycle capability extends battery life in portable devices, while the quiescent current is 200μA with no load, and drops to < 1μA in shutdown.

The internal synchronous switch is desired to increase efficiency without an external Schottky diode. The 1.2 MHz fixed switching frequency allows the using of tiny, low profile inductors and ceramic capacitors, which minimized overall solution footprint.

The HX1002 converters are available in the industry standard SOT-23-5L power packages (or upon request).

### Order Information

HX1002 – ① ②:

SYMBOL	DESCRIPTION
①	Denotes Output voltage: K : 1.2V Output B : 1.5V Output C : 1.8V Output G : 3.3 V Output A : Adjustable Output
②	Denotes Package Types: E: SOT-23-5L

## Typical Applications

### FIXED OUTPUT VOLTAGE

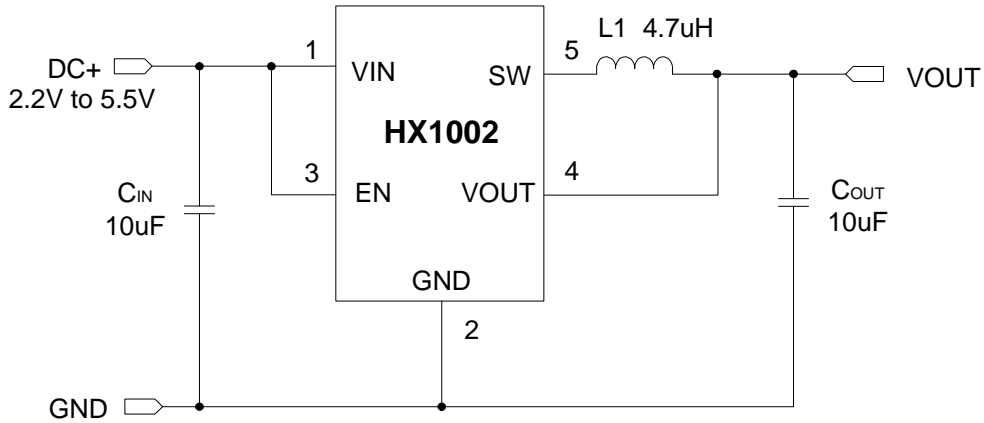
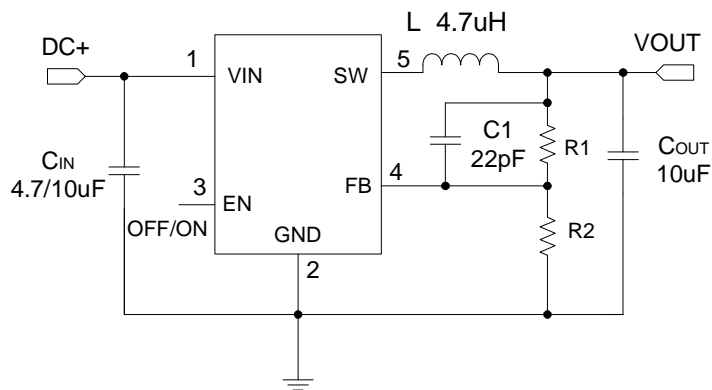

Figure 1: Typical Application Circuit

Model	VOUT (V)	VIN (V)	Mark
HX1002-KE	1.2	2.2~5.5	F1CE
HX1002-BE	1.5	2.5~5.5	F1F8
HX1002-CE	1.8	2.5~5.5	F1LE
HX1002-GE	3.3	3.4~5.5	F1F3

### ADJUSTABLE OUTPUT VOLTAGE



MODEL	VOUT (V)	MARK
HX1002-AES	Adjustable Output Voltage	F1F9

## Pin Assignment

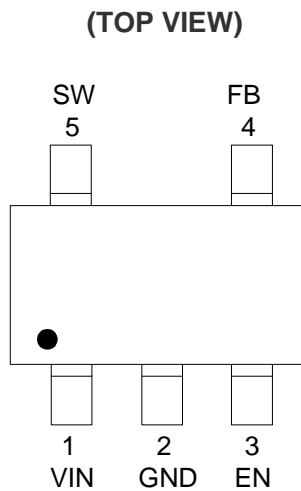

SOT-23-5L

PIN NUMBER SOT-23- 5L	PIN NAME	FUNCTION
1	VIN	Input
2	GND	Ground
3	EN	ON/OFF Control (High Enable)
4	FB	Feedback Pin
5	SW	Switch Output

## Absolute Maximum Ratings (Note 1)

- Power Dissipation.....Internally limited
- $V_{IN}$ .....- 0.3 V ~ + 6 V
- $V_{EN}$  .....- 0.3 V ~ ( $V_{IN} + 0.3$ ) V
- $V_{SW}$  .....- 0.3 V ~ ( $V_{IN} + 0.3$ ) V
- $V_{OUT}$ .....- 0.3 V ~ + 6 V
- $I_{SW}$  .....1.3A
- Operating Temperature Range .....- 40°C ~ + 85°C
- Lead Temperature (Soldering 10 sec.) .....+ 300°C
- Storage Temperature Range .....- 65°C ~ + 150°C
- Junction Temperature .....+ 125°C

**Note 1.** Stresses listed as the above “Absolute Maximum Ratings” may cause permanent damage to the device. These are for stress ratings. Functional operation of the device at these or any other conditions beyond those indicated in the operational sections of the specifications is not implied. Exposure to absolute maximum rating conditions for extended periods may remain possibility to affect device reliability.

## Electrical Characteristics

HX1002-CE: Operating Conditions:  $T_A=25^{\circ}\text{C}$ ,  $V_{\text{IN}}=3.6\text{V}$  unless otherwise specified.

SYMBOL	PARAMETER	CONDITIONS	MIN	TYP	MAX	UNIT
$V_{\text{OUT}}$	Output Voltage	$I_{\text{OUT}} = 100\text{mA}$ , $R1/R2=2$	1.75	1.80	1.85	V
$V_{\text{IN}}$	Input Voltage Range		2.5		5.5	V
$V_{\text{FB}}$	Regulated Voltage	$T_A = 25^{\circ}\text{C}$	0.588	0.6	0.612	V
$I_{\text{FB}}$	Feedback Current				$\pm 30$	nA
$\Delta V_{\text{FB}}$	$V_{\text{REF}}$	$V_{\text{IN}}=2.5\text{V}\sim 5.5\text{V}$		0.03	0.4	%/V
$F_{\text{OSC}}$	Oscillator Frequency	$V_{\text{FB}} = 0.6\text{V}$ or $V_{\text{OUT}} = 100\%$	0.9	1.2	1.4	MHz
$I_{\text{Q}}$	Quiescent Current	$V_{\text{FB}} = 0.5\text{V}$ or $V_{\text{OUT}} = 90\%$ , $I_{\text{LOAD}} = 0\text{A}$		200	300	$\mu\text{A}$
$I_{\text{S}}$	Shutdown Current	$V_{\text{EN}} = 0\text{V}$ , $V_{\text{IN}} = 4.2\text{V}$		0.1	1	$\mu\text{A}$
$I_{\text{PK}}$	Peak Inductor Current	$V_{\text{IN}} = 3\text{V}$ , $V_{\text{FB}} = 0.5\text{V}$ or $V_{\text{OUT}} = 90\%$ , Duty Cycle < 35%	0.75	0.9	1	A
$R_{\text{PFET}}$	$R_{\text{DS(ON)}}$ of P-Channel FET	$I_{\text{SW}} = 100\text{mA}$		0.3		$\Omega$
$R_{\text{NFET}}$	$R_{\text{DS(ON)}}$ of N-Channel FET	$I_{\text{SW}} = -100\text{mA}$		0.39		$\Omega$
$\text{EFFI}^*$	Efficiency	When connected to ext. components $V_{\text{IN}}=V_{\text{EN}}=2.7\text{V}$ , $V_{\text{OUT}}=2.5\text{V}$ , $I_{\text{OUT}}=100\text{mA}$		95		%
$\Delta V_{\text{OUT}}$	$V_{\text{OUT}}$ Line Regulation	$V_{\text{IN}}=2.5\text{V}\sim 5.5\text{V}$		0.03	0.3	%/V
$V_{\text{LOADREG}}$	$V_{\text{OUT}}$ Load Regulation			0.33		%

\*  $\text{EFFI} = [(\text{Output Voltage} \times \text{Output Current}) / (\text{Input Voltage} \times \text{Input Current})] \times 100\%$

## Typical Performance Characteristics

**Efficiency vs. Output Current  
(Vout=1.2V)**

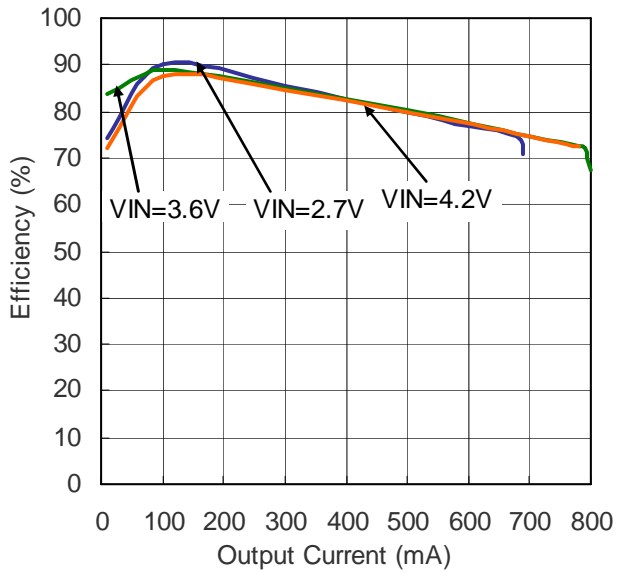

**Output Voltage vs. Load Current  
(Vin=3.6V, Vout=1.2V)**

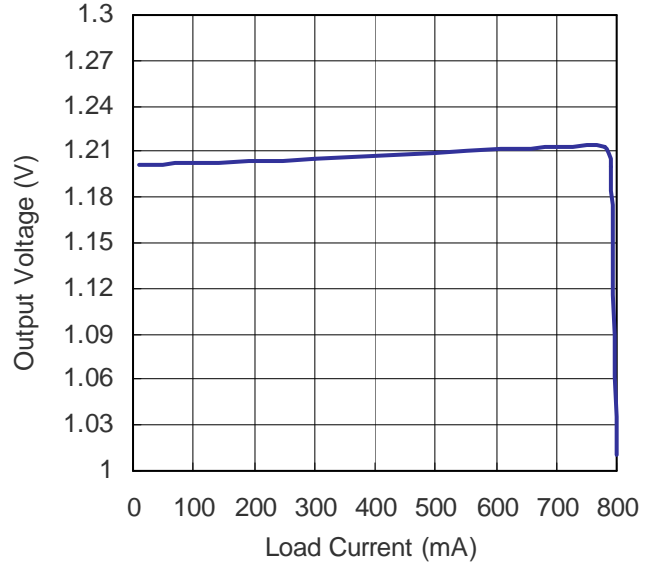

**Efficiency vs. Output Current  
(Vout=1.8V)**

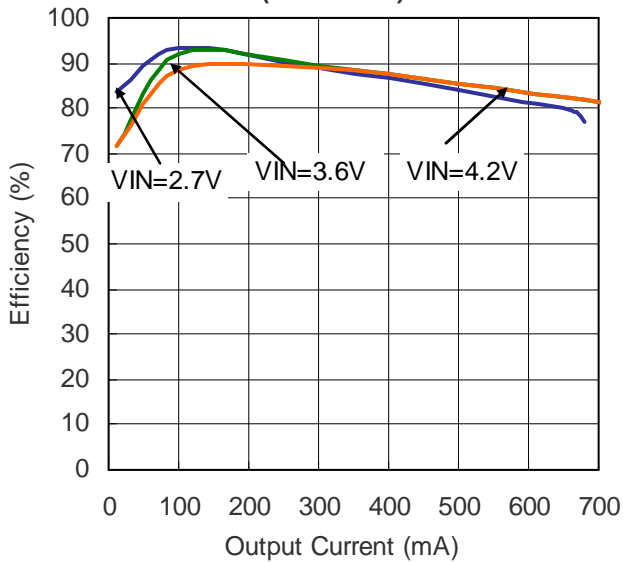

**Output Voltage vs. Load Current  
(Vin=3.6V, Vout=1.8V)**

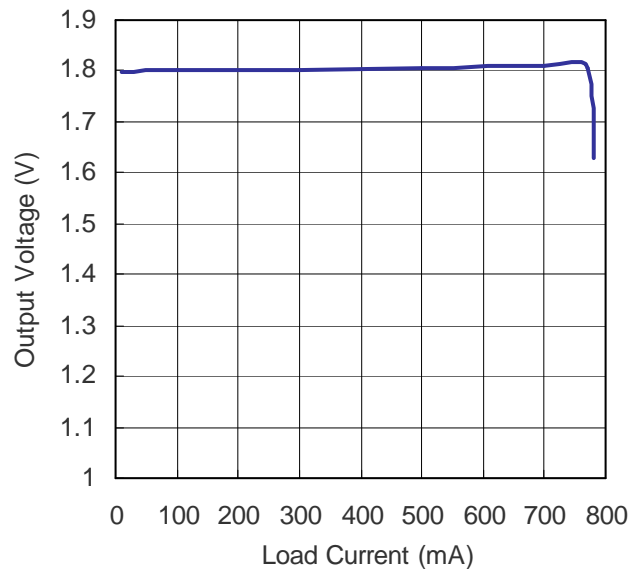

**Supply Current vs. Supply Voltage**  
( $V_{out}=1.8V$   $I_o=0A$ )

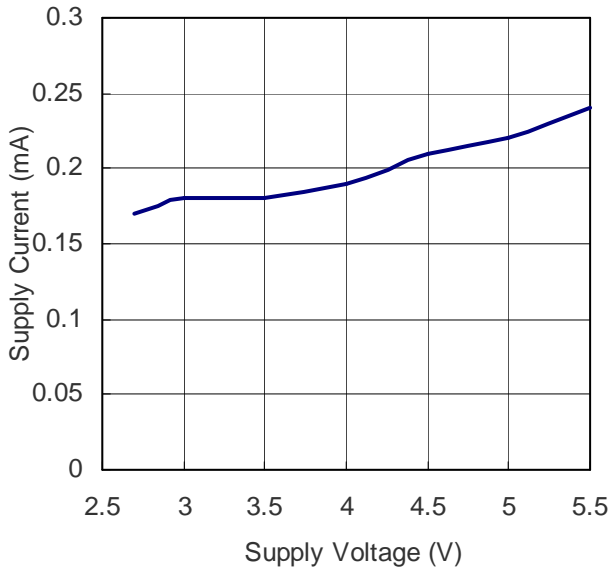

**Start-up from Shutdown**  
(1V/DIV 100ns/DIV)

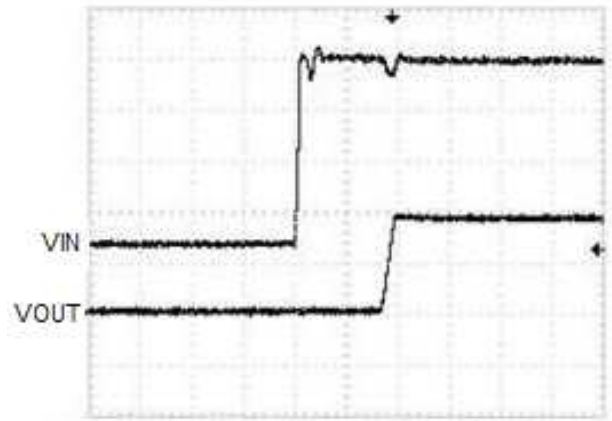

$V_{IN}=3.6V$   $V_{OUT}=1.8V$   $I_{LOAD}=0mA$

**Output Noise (10mV/DIV 200ns/DIV**  
**AC COUPLED)**

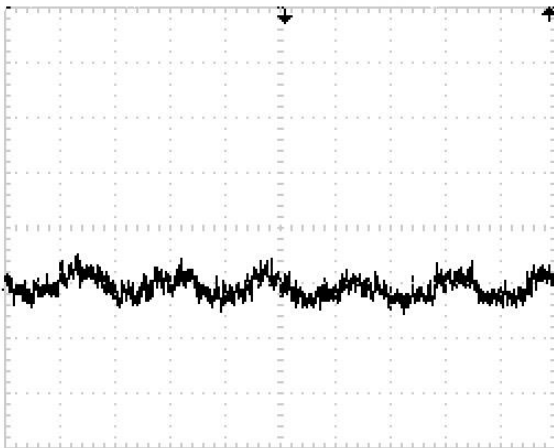

$V_{IN}=3.6V$   $V_{OUT}=1.8V$   $I_{LOAD}=200mA$

**Output Noise (100mV/DIV 2ms/DIV**  
**AC COUPLED)**

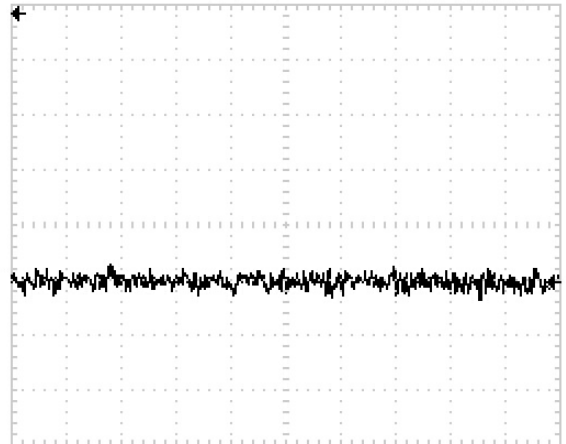

$V_{IN}=3.6V$   $V_{OUT}=1.8V$   $I_{LOAD}=0mA$

## Pin Description

**VIN (Pin 1):** Main Supply Pin. It must be closely decoupled to GND, Pin 2, with a 10 $\mu$ F or greater ceramic capacitor.

**GND (Pin 2):** Ground Pin.

**EN (Pin 3):** En Control Input. Forcing this pin above 1.3V enables the part. Forcing this pin below 0.7V can shut down the device. In shutdown, all functions are disabled drawing <1 $\mu$ A supply current. Do not leave EN floating.

**VOUT (HX1001-BE/CE/GE) / FB (HX1001-AES) (Pin 4):** Output Pin. In the nonadjustable version, the output voltage is fixed. In the adjustable version, the output voltage is set by a resistive divider according to the following formula:  $V_{OUT} = 0.6V \cdot [1 + (R1/R2)]$ .

**SW (Pin 5):** Switch Node Connection to Inductor. This pin connects to the drains of the internal main and synchronous power MOSFET switches.

## PCB Layout Guidelines

When laying out the printed circuit board, the following checklist should be used to ensure proper operation of the HX1002. Check the following in your layout:

1. The power traces, consisting of the GND trace, the SW trace and the  $V_{IN}$  trace should be kept short, direct and wide. prevent stray capacitive noise pick-up.
2. Put the input capacitor as close as possible to the device pins ( $V_{IN}$  and GND).
3. SW node is with high frequency voltage swing and should be kept small area. Keep analog components away from SW node to
4. Connect all analog grounds to a command node and then connect the command node to the power ground behind the output capacitors.
5. Keep the (-) plates of  $C_{IN}$  and  $C_{OUT}$  as close as possible.

## Application Information

The basic HX1002 application circuit is shown in Typical Application Circuit. External component selection is determined by the maximum load

### Inductor Selection

For most applications, the value of the inductor will fall in the range of 1 $\mu$ H to 4.7 $\mu$ H. Its value is chosen based on the desired ripple current. Large value inductors lower ripple current and small value inductors result in higher ripple currents. Higher  $V_{IN}$  or  $V_{OUT}$  also increases the ripple current as shown in equation (1). A reasonable starting point for setting ripple current is  $\Delta I_L = 280\text{mA}$  (40% of 700mA).

$$(1) \quad \Delta I_L = \frac{1}{(f)(L)} V_{OUT} \left( 1 - \frac{V_{OUT}}{V_{IN}} \right)$$

The DC current rating of the inductor should be at least equal to the maximum load current plus half the ripple current to prevent core saturation. Thus, a 840mA rated inductor should be enough for most applications (700mA + 140mA). For better efficiency, choose a low DC-resistance inductor.

Different core materials and shapes will change the size/current and price/current relationship of an inductor. Toroid or shielded pot cores in ferrite or perm alloy materials are small and don't radiate much energy, but generally cost more than powdered iron core inductors with similar electrical characteristics. The choice of which style inductor to use often depends more on the price vs. size requirements and any radiated field/EMI requirements than on what the HX1002 requires to operate.

### Output and Input Capacitor Selection

In continuous mode, the source current of the top MOSFET is a square wave of duty cycle  $V_{OUT}/V_{IN}$ . To prevent large voltage transients, a low ESR

current and begins with the selection of the inductor value and operating frequency followed by  $C_{IN}$  and  $C_{OUT}$ .

input capacitor sized for the maximum RMS current must be used. The maximum RMS capacitor current is given by:

$$C_{IN} \text{ required } I_{RMS} \cong I_{OMAX} \left[ \frac{V_{OUT}(V_{IN} - V_{OUT})}{V_{IN}} \right]^{1/2}$$

This formula has a maximum at  $V_{IN} = 2V_{OUT}$ , where  $I_{RMS} = I_{OUT}/2$ . This simple worst-case condition is commonly used for design because even significant deviations do not offer much relief. Note that the capacitor manufacturer's ripple current ratings are often based on 2000 hours of life. This makes it advisable to further derate the capacitor, or choose a capacitor rated at a higher temperature than required. Always consult the manufacturer if there is any question.

The selection of  $C_{OUT}$  is driven by the required effective series resistance (ESR).

Typically, once the ESR requirement for  $C_{OUT}$  has been met, the RMS current rating generally far exceeds the  $I_{RIPPLE(P-P)}$  requirement. The output ripple  $\Delta V_{OUT}$  is determined by:

$$\Delta V_{OUT} \cong \Delta I_L \left( \text{ESR} + \frac{1}{8fC_{OUT}} \right)$$

Where  $f$  = operating frequency,  $C_{OUT}$  = output capacitance and  $\Delta I_L$  = ripple current in the inductor. For a fixed output voltage, the output ripple is highest at maximum input voltage since  $\Delta I_L$  increases with input voltage.



Aluminum electrolytic and dry tantalum capacitors are both available in surface mount configurations. In the case of tantalum, it is critical that the capacitors are surge tested for use in switching power supplies. An excellent choice is the AVX TPS series of surface mount

tantalum. These are specially constructed and tested for low ESR so they give the lowest ESR for a given volume. Other capacitor types include Sanyo POSCAP, Kemet T510 and T495 series, and Sprague 593D and 595D series. Consult the manufacturer for other specific recommendations.

## Efficiency Considerations

The efficiency of a switching regulator is equal to the output power divided by the input power times 100%. It is often useful to analyze individual losses to determine what is limiting the efficiency and which change would produce the most improvement. Efficiency can be expressed as: Efficiency = 100% - (L1+ L2+ L3+ ...) where L1, L2, etc. are the individual losses as a percentage of input power. Although all dissipative elements in the circuit produce losses, two main sources usually account for most of the losses: VIN quiescent current and I<sup>2</sup>R losses. The VIN quiescent current loss dominates the efficiency loss at very low load currents whereas the I<sup>2</sup>R loss dominates the efficiency loss at medium to high load currents. In a typical efficiency plot, the efficiency curve at very low load currents can be misleading since the actual power lost is of no consequence.

1. The VIN quiescent current is due to two components: the DC bias current as given in the electrical characteristics and the internal main switch and synchronous switch gate charge currents. The gate charge current results from switching the gate capacitance of the internal power MOSFET switches. Each time the gate is

switched from high to low to high again, a packet of charge  $\Delta Q$  moves from VIN to ground. The resulting  $\Delta Q/\Delta t$  is the current out of VIN that is typically larger than the DC bias current. In continuous mode,  $I_{GATECHG} = f(Q_T + Q_B)$  where  $Q_T$  and  $Q_B$  are the gate charges of the internal top and bottom switches. Both the DC bias and gate charge losses are proportional to VIN and thus their effects will be more pronounced at higher supply voltages.

2. I<sup>2</sup>R losses are calculated from the resistances of the internal switches, R<sub>sw</sub> and external inductor R<sub>L</sub>. In continuous mode the average output current flowing through inductor L is “chopped” between the main switch and the synchronous switch. Thus, the series resistance looking into the SW pin is a function of both top and bottom MOSFET R<sub>DS(ON)</sub> and the duty cycle (DC) as follows:  $R_{SW} = R_{DS(ON)TOP} \times DC + R_{DS(ON)BOT} \times (1-DC)$  The R<sub>DS(ON)</sub> for both the top and bottom MOSFETs can be obtained from the Typical Performance Characteristics curves. Thus, to obtain I<sup>2</sup>R losses, simply add R<sub>sw</sub> to R<sub>L</sub> and multiply the result by the square of the average output current. Other losses including C<sub>IN</sub> and C<sub>OUT</sub> ESR dissipative losses and inductor core losses generally account for less than 2% of the total loss.

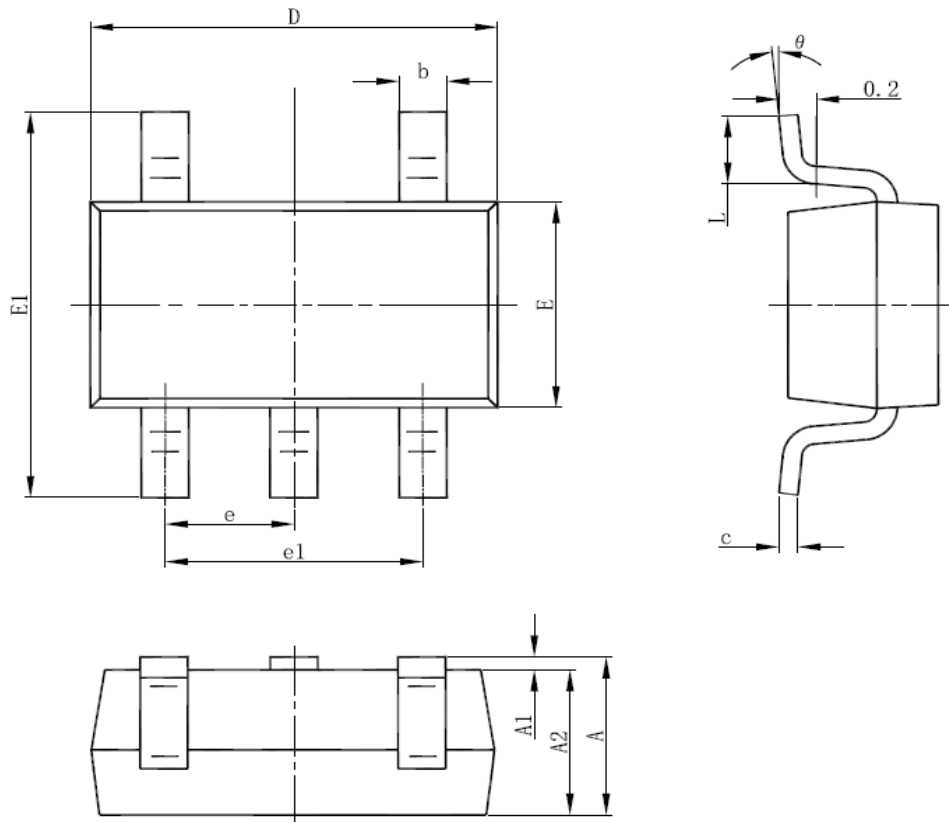
**Packaging Information**
**SOT-23-5L Package Outline Dimension**

Symbol	Dimensions In Millimeters		Dimensions In Inches	
	Min	Max	Min	Max
A	1.050	1.250	0.041	0.049
A1	0.000	0.100	0.000	0.004
A2	1.050	1.150	0.041	0.045
b	0.300	0.500	0.012	0.020
c	0.100	0.200	0.004	0.008
D	2.820	3.020	0.111	0.119
E	1.500	1.700	0.059	0.067
E1	2.650	2.950	0.104	0.116
e	0.950(BSC)		0.037(BSC)	
e1	1.800	2.000	0.071	0.079
L	0.300	0.600	0.012	0.024
theta	0°	8°	0°	8°

Subject changes without notice.