

CARBON FILM (FLAME RETARDANT)

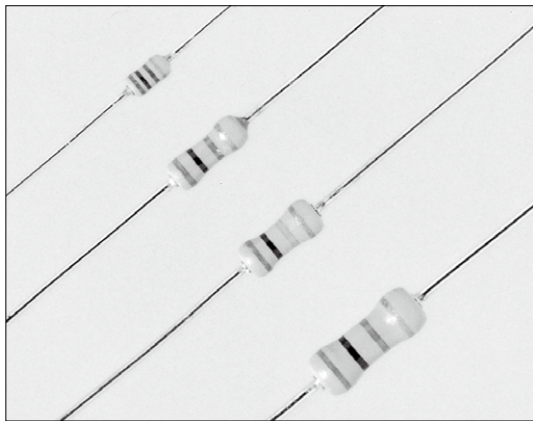

CFP 小型涂层绝缘型碳膜固定电阻器 (难燃性涂层产品)

Coat-Insulated Fixed Carbon Film Resistors (Flame retardant coating)



外观颜色: 绿色 Coating color: Green
表示: 颜色代码 Marking: Color code

特点 Features

- 相当 (UL94 V-0) 规定的难燃性涂层。
- 可以用于自动插装机。
- 于相同功率的贴片电阻相比更能耐受脉冲。
- 同样有1/4W的小型电阻器 (CFPS 1/4)。
- 对应欧盟RoHS的。
- Equivalent to flame retardant coat. (UL94 V-0)
- Automatic insertion is applicable.
- Stronger in pulse resistance than chip resistors of the same power.
- The smaller type of 1/4W (CFPS 1/4) is available.
- Products meet EU-RoHS requirements.

参考规格 Reference Standards

IEC 60115-2
JIS C 5201-2

结构图 Construction

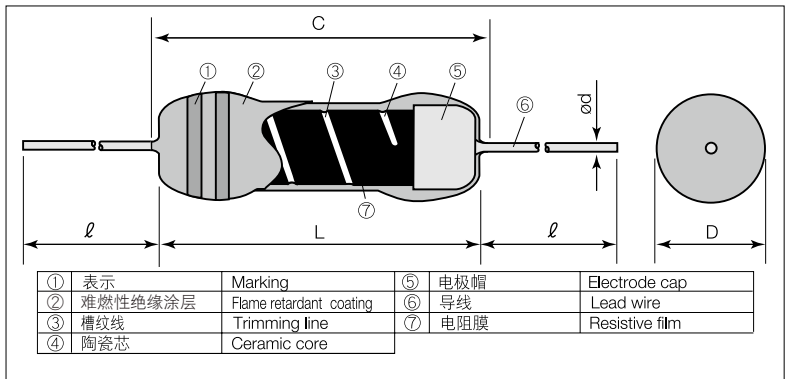

外形尺寸 Dimensions

型号 Type	尺寸 Dimensions (mm)				Weight (g) (1000pcs)
	L	C Max.	D	d (Nominal)	
CFPS1/4	3.2±0.2	3.4	1.7 ^{±0.05}	0.45	80
CFP1/4	6.3±0.5	7.1	2.3±0.3	0.6	160
CFPB1/2	9.0±1.0	11.0	3.5±0.5	0.7	290
CFPS1/2	6.3±0.5	7.1	2.85±0.3	0.6	520

- ※1 成型编码S可以对应盒装。 ※3 引线长度按照成型和编带而改变。
- ※1 Forming code S is applied for bulk type. ※3 Lead length changes depending on taping and forming type.
- ※2 Long对应定制产品。
- ※2 Long type is custom-made.

品名构成 Type Designation

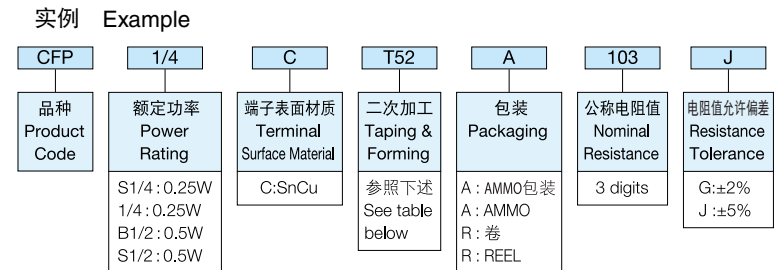

预知关于此产品含有的环境负荷物质详情 (除EU-RoHS以外), 请与我们联系。
编带细节请参考卷末附录C。

Contact us when you have control request for environmental hazardous material other than the substance specified by EU-RoHS.

For further information on taping, please refer to APPENDIX C on the back pages.

二次加工对应表 Taping & Forming Matrix

型号 Type	轴向编带 Axial Taping			径向编带 Radial Taping					M成形 M Forming	L成形 L Forming
	T26	T52	L52	VT	MT	MHT	VTP	GT		
CFPS 1/4C	○	○	-	-	○	○	-	-	M5F	-
CFP 1/4C	○	○	○	○	-	-	○	○	M10H	L10A
CFPS 1/2C	○	○	-	-	-	-	○	○	-	-
CFPB 1/2C	-	○	○	-	-	-	-	-	M12.5K	L12.5A

额定值 Ratings

型号 Type	额定功率 Power Rating	电阻值范围 Resistance Range (Ω) E24		电阻温度系数 T.C.R. (×10 ⁻⁶ /K)				最高使用电压 Max. Working Voltage	最高过载电压 Max. Overload Voltage	耐电压 Dielectric Withstanding Voltage	编带和包装数/AMMO包装 Taping & Q'ty/AMMO (pcs)		
		G: ±2%	J: ±5%	+350~-450	0~-700	0~-1000	0~-1300				T26A	T52A	L52A
CFPS 1/4C	0.25W	10~100k	2.2~1M	2.2Ω~47kΩ	51kΩ~100kΩ	110kΩ~330kΩ	360kΩ~1MΩ	250V	500V	300V	5,000	3,000	-
CFP 1/4C	0.25W	10~100k		2.2Ω~100kΩ	110kΩ~330kΩ	360kΩ~1MΩ	-	300V	600V	500V	2,000	-	2,000
CFPS 1/2C	0.5W	10~1M	2.2~1M	2.2Ω~91kΩ	100kΩ~1MΩ	-	-	350V	700V	700V	2,000	2,000	-
CFPB 1/2C	0.5W	10~1M		2.2Ω~100kΩ	110kΩ~1MΩ	-	-	400V	800V		-	-	2,000

额定环境温度 Rated Ambient Temperature: +70°C

使用温度范围 Operating Temperature Range: -55°C~+155°C

额定电压是√额定功率×公称电阻值所算出的值或表中最高使用电压两者中小的值为额定电压。

Rated voltage = √Power Rating × Resistance value or Max. working voltage, whichever is lower.

低功率型电阻器
Low Power Type Resistors

■ 负荷特性曲线 Derating Curve

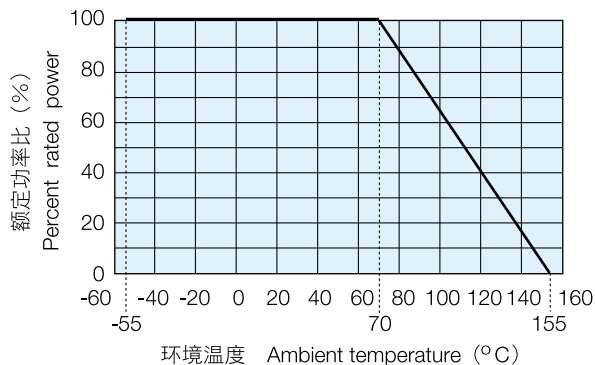

在环境温度70℃以上使用时，应参照左图负荷特性曲线，减小额定功率。

For resistors operated at an ambient temperature of 70°C or above, a power rating shall be derated in accordance with the left derating curve.

■ 性能 Performance

试验项目 Test Items	标准值 Performance Requirements ΔR± (%+0.05 Ω)		试验方法 Test Methods
	保证值 Limit	代表值 Typical	
电阻值 Resistance	在规定的允许偏差内 Within specified tolerance	—	测定位置距离本体10mm±1mm Measuring points are at 10mm±1mm from the end cap.
电阻温度系数 T.C.R.	在规定的值以内 Within specified T.C.R.	—	室温/上升100℃ Room temperature + 100°C
过载(短时间) Overload (Short time)	1	0.5	额定电压×2.5倍或者最高过载电压，取两者中低的一方施加5秒 Rated voltage×2.5 or Max. overload vol., whichever is lower, for 5s.
耐焊接热 Resistance to soldering heat	1	0.5	260°C±5°C, 10s±1s
端子强度 Terminal strength	不应出现导线外露，端子松弛的情况 No lead-coming off and loose terminals	—	Twist 360°, 5 times
温度突变 Rapid change of temperature	1	0.5	-55°C (30min.) / +125°C (30min.) 5 cycles
耐湿负荷 Moisture resistance	5	2.5	40°C±2°C, 90%~95%RH, 1000h 1.5小时ON、0.5小时OFF的周期 1.5h ON/0.5h OFF cycle
在70℃时的耐久性 Endurance at 70°C	3	1.5	70°C±2°C, 1000h 1.5小时ON、0.5小时OFF的周期 1.5h ON/0.5h OFF cycle
耐溶剂性 Resistance to solvent	外观无异常，标识可以容易地判读 No abnormality in appearance. Marking shall be easily legible.	—	进行2分钟的异丙醇超声波清洗 Ultrasonic washing with Isopropyl alcohol for 2 min. 输出功率 Power: 0.3W/cm², 频率 f: 28kHz, 温度 Temp: 35°C±5°C
阻燃性 Flame retardant	应当不会燃烧也不会自燃 No evidence of flaming or self-flaming.	—	耐火性: 将本产品于试验中燃烧15秒, 取出15秒, 循环5次 Flame test: The test flame shall be applied and removed for each 15s respectively to repeat the cycle 5 times. 过载阻燃性: 使用相当于额定功率的2倍, 4倍, 8倍, 16倍, 32倍的功率(AC), 各施加在本产品上1分钟, 每次直至断路。 但是, 请勿施加最高使用电压4倍以上的电压。 Overload flame retardant: Power (AC) corresponding to 2, 4, 8, 16 and 32 times the power rating shall be applied for each 1min. until disconnection occurs. However the applied voltage shall not exceed 4 times the maximum operating voltage.

低功率型电阻器
Low Power Type Resistors

■ 使用注意事项 Precautions for Use

- 焊剂等在本产品和安装的印刷电路板上附着离子性杂质时，其耐湿性·耐腐蚀性将受到影响。焊剂内有时含有氯·酸等离子性物质，为除去这些离子性物质应进行清洗。特别是使用无铅焊剂时，由于湿润性提高了，有时会含有大量离子性物质，所以在使用RMA系的焊锡或焊剂时，应充分进行清洗。并且，保管环境和安装条件、环境等，附着了汗·盐等离子性物质时，其耐湿性·耐腐蚀性也将受到影响。对于这种污染，为了除去这些离子性物质，应当进行清洗。
- 由于外装涂层具有难燃性特征，因此对抵抗外部的冲击较弱，请注意操作。请进行最小限度的清洗。刚刚清洗好以后的涂层比较脆弱，在产品完全干燥之前，请勿对涂层施加外力。产品干燥后，涂层将恢复原有强度，请注意在洗净后的20分钟内，勿对电阻器的涂层施加外力。特别请注意，请勿将PCB板堆放起来。
- Ionic impurities such as flux etc. that are attached to these products or those mounted onto a PCB, negatively affect their moisture resistance, corrosion resistance, etc. The flux may contain ionic substances like chlorine, acid, etc. Please wash them to get rid of these ionic substances especially when using lead-free solder that may contain much of the said substances for improving a wetting characteristic. Using RMA solder or RMA flux, or well-washing is needed. Also, attaching ionic substances such as perspiration, salt etc. by storage environments or mounting conditions/environments negatively affects their moisture resistance, corrosion resistance etc. Please wash them to remove the ionic substances when they are polluted.
- Be careful to handle these resistors because outer coatings are comparatively weak to outer shock due to flameproof special coats. Please wash them to a minimum. No external force is given to the coating films until they are well dried because the coating films become weaker right after washing. The original strength will be returned after they are dried, so please pay attention not to apply any external force onto the coating film of resistors for 20 minutes after drying. Especially no PC boards shall be piled up.