

MF 涂层绝缘型金属膜固定电阻器 Coat-Insulated Fixed Metal Film Resistors

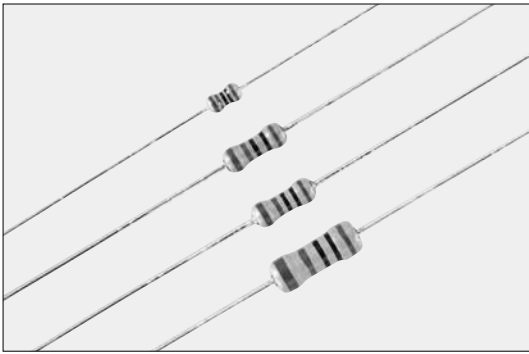

外观颜色: 亮灰色 Coating color: Light gray
表示: 颜色代码 Marking: Color code

■ 结构图 Construction

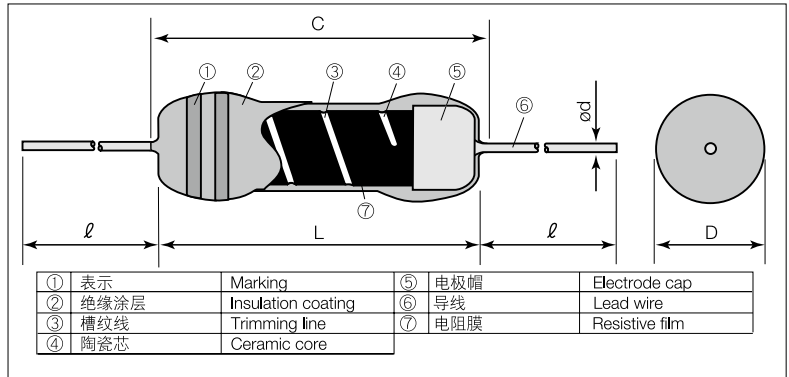

■ 特点 Features

- 是高精度、低T.C.R.的金属膜电阻器。
- 可以用于自动插装机。
- 可以进行各种成形加工。
- 长期稳定性优异。
- 对应欧盟RoHS。
- 对应(取得数据)AEC-Q200。(MF1/2除外)
- High precision and low T.C.R. metal film resistors.
- Automatic insertion is applicable.
- Various formings are available.
- Excellent stability for a long time.
- Products meet EU-RoHS requirements.
- AEC-Q200 qualified (Exemption MF1/2).

■ 外形尺寸 Dimensions

型号 Type	尺寸 Dimensions (mm)				Weight (g) (1000pcs)
	L	C Max.	D	d (Nominal)	
MFS1/4	3.2±0.2	3.4	1.7 ^{+0.2} _{-0.1}	0.45	120
MF1/4	6.3±0.5	7.1	2.3±0.3	0.6	215
MFS1/2					215
MF1/2	9.0±1.0	11.1	3.5±0.4		360

※ 引线长度按照成型和编带不同而改变。
※ Lead length changes depending on taping and forming type.

■ 参考标准 Reference Standards

IEC 60115-2
JIS C 5201-2
EIAJ RC-2137

■ 品名构成 Type Designation

实例 Example

MF 品种 Product Code	1/4 额定电力 Power Rating S1/4: 0.25W 1/4: 0.25W S1/2: 0.5W 1/2: 0.5W	D 电阻温度系数 T.C.R. (×10 ⁻⁶ /K) C: ±50 D: ±100 L: ±200	C 端子表面材质 Terminal Surface Material C: SnCu	T52 二次加工 Taping & Forming 参照下述 See table below	A 包装 Packing A: AMMO包装 A: AMMO R: 卷 R: REEL	1002 公称电阻值 Nominal Resistance D, F: 4 digits G: 3 digits	F 阻值允许偏差 Resistance Tolerance D: ±0.5% F: ±1% G: ±2%
---------------------------------	--	--	--	---	--	---	--

预知关于此产品含有的环境负荷物质详情(除EU-RoHS以外), 请与我们联系。

编带细节请参考卷末附录C.

Contact us when you have control request for environmental hazardous material other than the substance specified by EU-RoHS.

For further information on taping, please refer to APPENDIX C on the back pages.

■ 二次加工对应表 Taping & Forming Matrix

型号 Type	轴向编带 Axial Taping		径向编带 Radial Taping				U成形 U Forming	M成形 M Forming				
	T26	T52	VT	VTP	VTE	MT	U	M5				
MFS1/4□C	○	○	○	-	-	○	○	M5F	M5R	-	-	-
MF1/4□C	○	○	○	○	○	-	○	-	-	M10F	M12.5R	-
MFS1/2□C	○	○	○	○	○	-	-	-	-	M10R	-	-
MF1/2□C	-	○	-	-	-	-	-	-	-	-	M12.5R	M15R

□: T.C.R.

■ 额定值 Ratings

型号 Type	额定功率 Power Rating	电阻温度系数 T.C.R. (×10 ⁻⁶ /K)	电阻值范围 Resistance Range (Ω)			最高使用电压 Max. Working Voltage	最高过载电压 Max. Overload Voltage	耐电压 Dielectric Withstanding Voltage	编带和包装数/AMMO包装 Taping & Q'ty/AMMO (pcs)					
			D: 0.5% E24 • E192	F: ±1% E24 • E96	G: ±2% E24				T26A	T52A				
MFS1/4CC	0.25W	C: ±50	49.9~562k	10~1M	-	250V	500V	300V	3,000	3,000				
MFS1/4DC		D: ±100							3,000	3,000				
MF1/4CC		C: ±50	10~2.21M	10~2.21M					2,000	2,000				
MF1/4DC		D: ±100							2,000	2,000				
MF1/4LC	L: ±200	-	1.0~10	0.51~10	-	-	500V	2,000	2,000					
MFS1/2CC	0.5W	C: ±50	10~1M	10~2.21M	-	350V	700V	700V	2,000	2,000				
MFS1/2DC		D: ±100							2,000	2,000				
MF1/2CC		C: ±50	10~5.05M	10~4.99M					-	-	-	-	2,000	2,000
MF1/2DC		D: ±100											10~5.11M	2,000
MF1/2LC	L: ±200	-	1.0~10	0.51~10	-	-	-	2,000	2,000					

额定环境温度 Rated Ambient Temperature: +70°C

使用温度范围 Operating Temperature Range: -55°C~+155°C

额定电压是√额定功率×公称电阻值所算出的值或表中最高使用电压两者中小的值为额定电压。

Rated voltage = √Power Rating × Resistance value or Max. working voltage, whichever is lower.

本样本手册中记载的产品规格如有变更, 恕不一一奉告。订购以及使用之前, 请仔细确认规格书的内容。

用于车载设备、医疗设备、航空设备以及其它涉及人身安全、或可能引起重大损失的设备上时, 请务必先与我公司联系。这些产品在这类用途中出现故障或失灵可能导致人身事故或严重损坏。

Specifications given herein may be changed at any time without prior notice. Please confirm technical specifications before you order and/or use.

Contact our sales representatives before you use our products for applications including automobiles, medical equipment and aerospace equipment.

Malfunction or failure of the products in such applications may cause loss of human life or serious damage.

■ 负荷特性曲线 Derating Curve

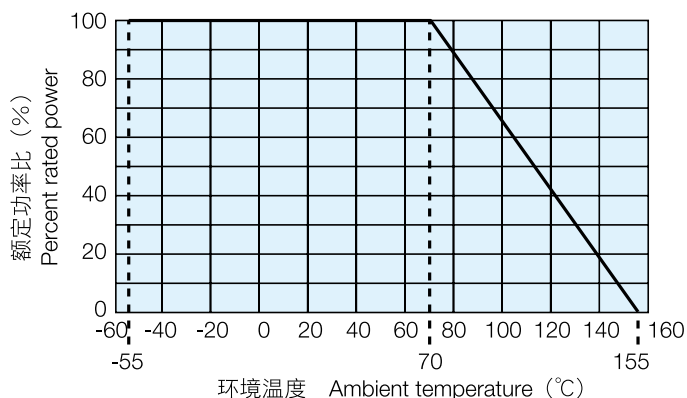

在环境温度70℃以上使用时，应按照上图负荷特性曲线，减小额定功率。

For resistors operated at an ambient temperature of 70°C or above, a power rating shall be derated in accordance with the above derating curve.

■ 性能 Performance

试验项目 Test Items	标准值 Performance Requirements $\Delta R \pm$ (%+0.05 Ω)		试验方法 Test Methods
	保证值 Limit	代表值 Typical	
电阻值 Resistance	在规定的允许偏差内 Within specified tolerance	—	+25°C
电阻温度系数 T.C.R.	在规定的值以内 Within specified T.C.R.	—	+25°C/+125°C
过载（短时间） Overload (Short time)	0.5	0.3	额定电压×2.5倍或最高过载电压低的一方施加5秒钟。：MFS1/4, MF1/4, MF1/2 额定电压×2倍或最高过载电压低的一方施加5秒钟。：MFS1/2 Rated voltage × 2.5 or Max. overload vol., whichever is lower, for 5s : MFS1/4, MF1/4, MF1/2 Rated voltage × 2 or Max. overload vol., whichever is lower, for 5s : MFS1/2
耐焊接热 Resistance to soldering heat	0.75: MFS1/4 0.5: MF1/4, MFS1/2, MF1/2	0.4: MFS1/4 0.25: MF1/4, MFS1/2, MF1/2	260°C ± 5°C, 10s ± 1s
温度突变 Rapid change of temperature	1.0	0.3	-55°C (30min.) / +155°C (30min.) 5 cycles
耐湿负荷 Moisture resistance	1.5: MFS1/4 1: MF1/4, MFS1/2, MF1/2	1: MFS1/4 0.75: MF1/4, MFS1/2, MF1/2	40°C ± 2°C, 90%~95%RH, 1000h 1.5小时ON、0.5小时OFF的周期 1.5h ON/0.5h OFF cycle
在70℃时的耐久性 Endurance at 70°C	1.5: MFS1/4 1: MF1/4, MFS1/2, MF1/2	1: MFS1/4 0.75: MF1/4, MFS1/2, MF1/2	70°C ± 2°C, 1000h 1.5小时ON、0.5小时OFF的周期 1.5h ON/0.5h OFF cycle

■ 使用注意事项 Precautions for Use

- 焊剂等在本产品和安装的印刷电路板上附着离子性杂质时，其耐湿性・耐腐蚀性将受到影响。焊剂内有时含有氯・酸等离子性物质，为除去这些离子性物质应进行清洗。特别是使用无铅焊剂时，由于湿润性提高了，有时会含有大量离子性物质，所以在使用RMA系的焊锡或焊剂时，应充分进行清洗。并且，保管环境和安装条件、环境等，附着了汗・盐等离子性物质时，其耐湿性・耐腐蚀性也将受到影响。对于这种污染，为了除去这些离子性物质，应当进行清洗。
- Ionic impurities such as flux etc. that are attached to these products or those mounted onto a PCB, negatively affect their moisture resistance, corrosion resistance, etc. The flux may contain ionic substances like chlorine, acid, etc. Please wash them to get rid of these ionic substances especially when using lead-free solder that may contain much of the said substances for improving a wetting characteristic. Using RMA solder or RMA flux, or well-washing is needed. Also, attaching ionic substances such as perspiration, salt etc. by storage environments or mounting conditions/environments negatively affects their moisture resistance, corrosion resistance etc. Please wash them to remove the ionic substances when they are polluted.