

FUSING RESISTOR

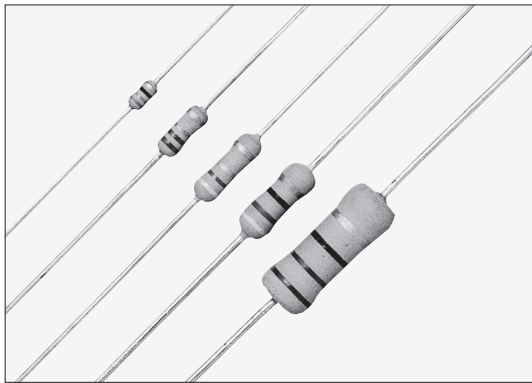

RF 涂层绝缘型保险丝电阻器 Coat-insulated Fusing Resistors



外观颜色: 蓝色 Coating color: Blue
表示: 颜色码 Marking: Color code

特点 Features

- 通常作为电阻发挥功能。
- 对异常时的过载, 迅速熔断, 保护电路。
- 难燃性涂层 (相当于UL94 V-0)。
- 对应欧盟RoHS。
- Function as a resistor in normal condition.
- Quick fusing protects circuit from excessive overload at an abnormal time.
- Flame retardant coating. (Equivalent to UL94 V-0.)
- Products meet EU-RoHS requirements.

参考规格 Reference Standards

IEC 60115-1
JIS C 5201-1
EIAJ RC-2125

结构图 Construction

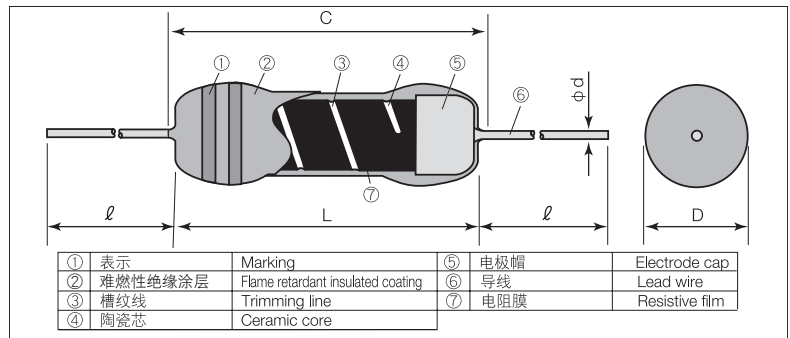

外形尺寸 Dimensions

型号 Type	尺寸 Dimensions (mm)				Weight (g) (1,000pcs)
	L	C Max.	D	d (Nominal)	
RF16	3.2±0.2	3.4	1.7 ^{+0.25} ₋₀	0.45	120
RF25	6.3±0.5	7.1	2.3±0.3	0.6	230
RF50	8.5±0.5	9.5	3.0±0.3		290
RF1	9.0±1.0	11.1	3.5±0.5		460
RF2	15.5±1.0	18.0	6.0±1.0	0.8	1410

※ 引线长度按照成型和编带的不同而改变。
※ Lead length changes depending on taping and forming type.

品名构成 Type Designation

实例 Example

RF	25	C	T52	A	100	J
品种 Product Code	额定功率 Power Rating 16: 0.17W 25: 0.25W 50: 0.5W 1: 1W 2: 2W	端子表面材质 Terminal Surface Material C: SnCu	二次加工 Taping & Forming 参照下述 See table below	包装 Packaging A: AMMO包装 A: AMMO R: 卷 R: REEL	公称电阻值 Nominal Resistance 3 digits	阻值允许偏差 Resistance Tolerance J: ±5%

预知关于此产品含有的环境负荷物质详情 (除EU-RoHS以外), 请与我们联系。
编带细节请参考卷末附录C。

Contact us when you have control request for environmental hazardous material other than the substance specified by EU-RoHS.

For further information on taping, please refer to APPENDIX C on the back pages.

二次加工对应表 Taping & Forming Matrix

型号 Type	轴向编带 Axial Taping			径向编带 Radial Taping					L成形 L Forming					M成形 M Forming			
	T26	T52	T521	MHT	VTP	VTE	VT	GT	L10A	L12.5A	L15A	L20A	L25A	M5	M10	M12.5	M15
RF16C	○	○	-	○	-	-	-	-	-	-	-	-	-	M5F	-	-	-
RF25C	○	○	-	-	○	-	○	-	○	-	-	-	-	-	M10X	-	-
RF50C	-	○	-	-	-	-	-	○	-	○	-	-	-	-	-	M12.5E	-
RF1C	-	○	-	-	-	-	-	○	-	○	-	○	-	-	-	-	M15F
RF2C	-	-	○	-	-	-	-	○	-	-	-	○	○	-	-	-	-

额定值 Ratings

型号 Type	额定功率 Power Rating	电阻值范围 Resistance Range (Ω) (E24) J: ±5%	熔断特性 Fusing Characteristics						电阻温度系数 T.C.R. (×10 ⁻⁶ /K)	耐电压 Dielectric Withstanding Voltage	编带和包装/AMMO包装 Taping&Q'ty/AMMO pack (pcs)				
			熔断功率 Fusing Power			熔断时间 Fusing Time					T26A	T52A	T521A		
RF16C	0.17W	1.0~1k	-	-	-	3W 1Ω~4.7Ω	2.5W 5.1Ω~1kΩ	-	60sec Max.	±1000: R<4.7Ω ±350: R≥5.1Ω	250V	2,000	2,000	-	
RF25C	0.25W	0.1~10k	10W 0.1Ω~0.18Ω	7.5W 0.2Ω~0.43Ω	6.25W 0.47Ω~0.91Ω	-	3.75W 1Ω~4.7Ω 2.4kΩ~10kΩ	3W 5.1Ω~2.2kΩ	30sec Max.			300V	2,000	2,000	-
RF50C	0.5W	0.1~15k	-	-	12.5W 0.1Ω~0.43Ω	-	7.5W 0.47Ω~2Ω 1.1kΩ~15kΩ	6W 2.2Ω~1kΩ	350V			-	2,000	-	
RF1C	1W	0.1~10k	-	30W 0.1Ω~0.18Ω	25W 0.2Ω~0.43Ω	-	15W 0.47Ω~2Ω 1.1kΩ~10kΩ	12W 2.2Ω~1kΩ	600V			-	2,000	-	
RF2C	2W	1.0~3k	-	-	-	36W 1Ω~3.6Ω	30W 1.1kΩ~3kΩ	24W 3.9Ω~1kΩ					-	-	500

额定环境温度 Rated Ambient Temperature: +70°C

使用温度范围 Operating Temperature Range: -45°C~+155°C

额定电压是√额定功率×公称电阻值所算出的值。

Rated voltage = √Power Rating × Resistance value.

本样本册中记载的产品规格如有变更, 恕不一一奉告。订购及使用之前, 请仔细阅读规格表的内容。
用于车载设备、医疗设备、航空设备以及其他涉及人身安全、或可能引起重大损失的设备上时, 请务必事先与我司联系。这些产品在这类用途中出现故障或失灵可能导致人身事故或严重损坏。
Specifications given herein may be changed at any time without prior notice. Please confirm technical specifications before you order and/or use.
Contact our sales representatives before you use our products for applications including automotives, medical equipment and aerospace equipment.
Malfunction or failure of the products in such applications may cause loss of human life or serious damage.

■ 负荷特性曲线 Derating Curve

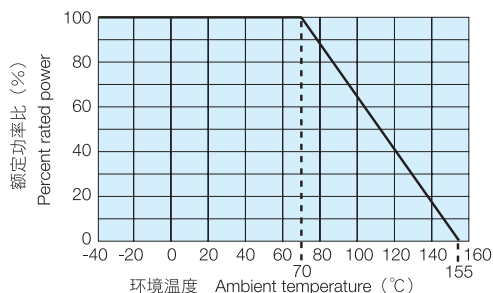

在环境温度70℃以上使用时，应照左图负荷特性曲线，减小额定功率。
For resistors operated at an ambient temperature of 70°C or above, a power rating shall be derated in accordance with the above derating curve.

■ 性能 Performance

试验项目 Test Items	标准值 Performance Requirements $\Delta R \pm (\% + 0.05 \Omega)$		试验方法 Test Methods
	保证值 Limit	代表值 Typical	
电阻值 Resistance	在规定的允许偏差内 Within specified tolerance	-	25°C
电阻温度系数 T.C.R.	在规定的允许偏差内 Within specified tolerance	-	室温/100°C以上 Room temperature + 100°C
过载 (短时间) Overload (Short time)	1	0.5	额定电压 × 2.5倍施加5秒钟。 Rated voltage × 2.5 for 5s
耐焊接热 Resistance to soldering heat	1	0.5	350°C ± 10°C, 3.5s ± 0.5s or 260°C ± 5°C, 10s ± 1s
温度突变 Rapid change of temperature	1	0.5	-40°C (30min.) / +85°C (30min.) 5 cycles
耐湿负荷 Moisture resistance	5	2.5	40°C ± 2°C, 90%~95%RH, 1000h 1.5小时ON、0.5小时OFF的周期 1.5h ON/0.5h OFF cycle
在70°C时的耐久性 Endurance at 70°C	5	2.5	70°C ± 2°C, 1000h 1.5小时ON、0.5小时OFF的周期 1.5h ON/0.5h OFF cycle
耐溶剂性 Resistance to solvent	应当外观没有异常，表示容易辨认。 No abnormality in appearance. Marking shall be easily legible	-	在异丙醇中浸渍30秒钟。 The resistor shall be immersed in IPA for 30 sec.
阻燃性 Flame retardant	应不发火和自动发火。 No evidence of flaming or self-flaming.	-	耐火性：把试验火焰在主体上烧15秒，取下15秒，5个循环。 过载耐燃性：相当于额定功率的2、4、8、16、32倍。把电力分别施加1分钟直到断线。 Flame test : The test flame shall be applied and removed for each 15 sec respectively to repeat the cycle 5 times. Overload flame retardant: Power corresponding to 2, 4, 8, 16 and 32 times the power rating shall be applied for each 1min. until disconnection occurs.

■ 熔断特性实例 Example of Fusing Characteristics

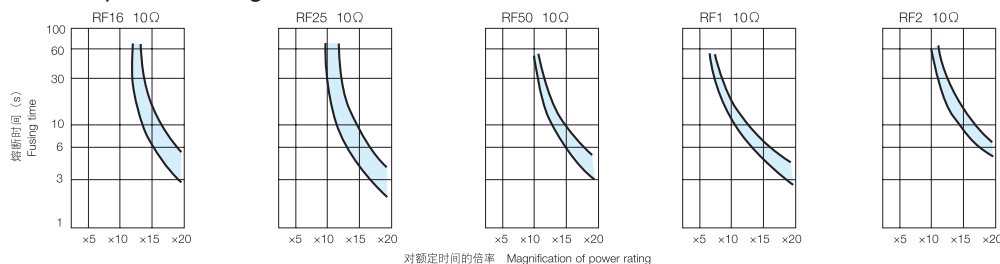

■ 使用注意事项 Precautions for Use

- 由于包装涂层是难燃性特种涂料，对外部冲击比较脆弱，因此在使用时应注意。清洗应在最小限度清洗后涂层膜比较脆弱，因此，在充分干燥以前，不要在涂层膜上施加外力。由于要干燥后才恢复到原来强度。因此，应注意，在清洗后约20分钟以内，在电阻的涂层膜上不要施加外力。特别不要进行基板的堆叠等。
- 最高开路电压，是指在电路中保险丝电阻成开放状态时，在电阻两端所能施加电压的最大值，因产品形状，电阻值的不同，会个别地规定。最高开路电压，是相当额定电压一千倍的电压，或者在下表所示电压中低的一方的电压。不管是设备正常动作时、异常动作时，电阻端子间所施加的电压应低于最高开路电压使用。
- Be careful to handle these resistors because outer coatings are comparatively weak to outer shock due to flameproof special coats. Please wash them to a minimum. No external force is given to the coating films until they are well dried because the coating films become weaker right after washing. The original strength will be returned after they are dried, so please pay attention not to apply any external force onto the coating film of resistors for 20 minutes after drying. Especially no PC boards shall be piled up.
- Maximum open-circuit voltage is the maximum value of the voltage applicable to both ends of resistors, when a fuse resistor becomes open conditions in a circuit. It differs according to the form of a product and a resistance value and is specified individually. The maximum open-circuit voltage is the lower one, whichever the voltage 1000 times of the power rating or the voltage shown in below table. Use the components under the voltage applied between the terminals of resistors to be under the maximum open-circuit voltage regardless of normal operating or abnormal operating time of equipment.

额定功率 Rated Power	0.17W	0.25W	0.5W	1W	2W
最高开路电压 Maximum Open-Circuit Voltage	100V	200V	250V	300V	300V