

NOTES :
 1.Specification:

- 1>.Operating force:1000gMax
- 2>.Operating Temperature: -30° to+85°
- 3>.Storage Temperature: -40° to+85°
- 4>.Mechanical Life: 3000cycles minimum

2. PLATING:
 GOLD FLASH 1u"(min.) SOLDER TAIL,
 3u" GOLD PLATING ON THE CONTACT AREA,
 WITH 50u" NICKEL UNDERPLATING OVERALL.

3. PART NUMBER DESCRIPTION

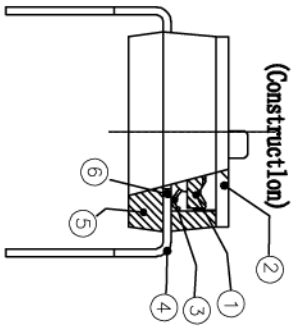
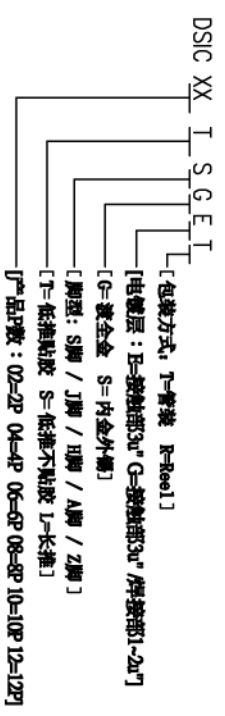

Number	Part Name	Material	Finished
①	Actuator	UL94 V0	White
②	Cover	UL94 V0	Black
③	Movable	Copper Alloy	3u"Gold
④	Terminal	Brass	1u"Gold
⑤	Base	UL94 V0	Black
⑥	Terminal Contact	Brass	3u"Gold

TOLERANCE UNLESS OTHERWISE SPECIFIED		INSPECTION	
LINER	ANGLES	COPY	PROJECTION
.0 ± 0.10	0 ± 1°		
.00 ± 0.05	0 ± 0.5°		
.000± 0.03	.00±		
DESIGN	ER XIN LU	04/12/12	
DRAWING			
CHECK			
APPRO.			

东莞市广智实业有限公司

BY DISC SERIES PITCH 2.54mm
 TYPE HOUSING
 PRODUCT FAMILY DSTC SERIES
 PRAT NO. DSTC02LHGET
 FILE NO. DSTC02LHGET-A
 SIZE UNIT SCALE SHEET REV.
 A4 mm 2 : 1 10F1 A