

60A SCR: 60A 非絕緣型 塑封 高壓 單向可控矽 【器件參數】

RoHS

無鉛產品提供SGS環保認證, 符合歐美RoHS環保指令標準

QUICK REFERENCE 【參考特性】

產品型號 Part Number	工業型號 Industry Part No	通態電流均方值 $I_{T(RMS)}$ (A)	斷態重復峰值電壓 V_{DRM} / V_{RRM} (V)	門極觸發電流 $I_{GT}(\mu A/mA)$	封裝外形 Package	包裝方式 Packing	元件標識 Marking
BCB60-800	60A以下 同等規格 所有SCR品種	60A	800 V	$\leq 80mA$	TO-3P or TO-247	30Pcs/Tube 600Pcs/Box 每管30只 每盒600只 5.6g / Pcs 每枚重量5.6克	
BCB60-1000			1000 V				
BCB60-1200			1200 V				
BCB60-1400			1400 V				
BCB60-1600			1600 V				
BCB60-1800			1800 V				
適用範圍	廣泛應用於無功補償、固態繼電器、電力模塊等產品。					H: HAOHAI KKG: 註冊商標 aa: 出廠年份 bb: 出廠自然周	
產品特征 Explain	①內部芯片採用NPNP四層結構的矽單向器件。 ②台面玻璃鈍化、多層金屬電極工藝。 ③單面台面結構, 具有較高的阻斷電壓和抗電流衝擊能力。						

PINNING: TO-247 【TO-247 or TO-3P 直插、非絕緣型、半塑封】

【BCB為非絕緣型: 中間管腳T2與散熱片Tab導通】

Pin 管腳排列	Symbol 對應極性	Description 極性名詞	Description 極性含義	Practicality in Pin Arrange 元件實物與管腳排列對照	Pin Polarity Circuit diagram 腳位與極性之電路符號表示
1	K	Cathode	陰極		$1=K$ $2=A$ $3=G$ $4=Tab$
2	A	Anode	陽極		
3	G	Gate	門-控制極		
4	Tab	Tab	散熱片		

ABSOLUTE RATINGS (Limiting Values) 【額定值參數】

SYMBOL 符號表示	Parameter & Test Conditions 符號含義及參數測試條件說明	Value 數值	Unit 單位
$I_{T(AV)}$	通態平均電流均方值: On-State RMS Current $T_J = 80^\circ C$	60	A
$I_{T(RMS)}$	通態均方根電流 $T_J = 80^\circ C$	85	
I_{TSM}	通態浪涌電流 $tp = 10\text{ ms}$	1250	
I_{GM}	門極峰值電流 $tp = 20\ \mu S$	2	W
P_{GM}	門極平均峰值功率: Forward Peak Gate Power Pulse Width $\leq 1\ \mu S, T_J = 80^\circ C$	20	
$P_{G(AV)}$	門極平均散耗功率: Forward Average Gate Power $T_J = 125^\circ C$	2	V
V_{DRM} or V_{RRM}	斷態重復峰值電壓: Peak Repetitive Off-State Voltage ($T_J = -40 \sim 125^\circ C$, Sine Wave, 50~60Hz; Gate Open) 見參考特性對應說明	800~1800	
T_J	工作結溫: Operating Junction Temperature Range @ Rate V_{RRM} and V_{DRM}	-40 ~ +125	
T_{stg}	貯存溫度: Storage Temperature Range	-40 ~ +150	$^\circ C$
T_L	引腳承受錫焊極限溫度: Maximum Lead Temperature for Soldering Purposes 1/8, from Case for 10 Seconds	260	

ELECTRICAL CHARACTERISTICS ($T_J = 25^\circ C$ Unless Otherwise Noted) 【電參數】

SYMBOL 符號表示	Parameter & Test Conditions 參數符號含義及測試條件說明	Min 最小值	Typ 典型值	Max 最大值	Unit 單位
I_{GT}	門極觸發電流: $V_D = 12V, R_L = 30\ \Omega$ ($T_J = 25^\circ C$)	10	→	80	mA
I_H	維持電流: Holding Current ($I_T = 1A$)	→	→	100	
I_L	擎住電流: $I_G = 1.2 I_{GT}$	→	→	150	
I_{DRM1}	斷態峰值電流	$V_D = V_{DRM}, T_J = 25^\circ C$	→	→	μA
I_{DRM2}		$V_D = V_{DRM}, T_J = 125^\circ C$	→	→	
I_{RRM1}	反向峰值電流	$V_D = V_{RRM}, T_J = 25^\circ C$	→	→	
I_{RRM2}		$V_D = V_{RRM}, T_J = 125^\circ C$	→	→	
V_{GT}	門極觸發電壓: Gate Trigger Voltage ($V_D = 12V, R_L = 30\ \Omega$)	→	→	1.5	V
V_{GD}	門極不觸發電壓: Gate Non-Trigger Voltage ($V_D = V_{DRM}, R_L = 1K\ \Omega, T_J = 125^\circ C$)	0.25	←	←	
V_{TM}	通態峰值電壓: Peak Forward On-State Voltage ($I_{TM} = 110A, tp = 380\ \mu s$)	→	→	1.8	
dv/dt	斷態臨界電壓上升率: $V_D = 2/3 V_{DRM}, T_J = 125^\circ C$, 門極開路	1000	→	→	$V/\mu s$
di/dt	通態電流臨界上升率: $V_D = 2/3 V_{DRM}, tp = 200\ \mu s, I_g = 0.3A, di/dt = 0.3A/\mu s, T_J = 125^\circ C$	→	→	150	$A/\mu s$

支持綠色環保!

該產品已實行無鉛制程封裝, 符合RoHS環保標準。

RoHS



SGS

MECHANICAL DATA TO-247 or TO-3P 封裝尺寸 單位:毫米與英寸對照 mm & Inches

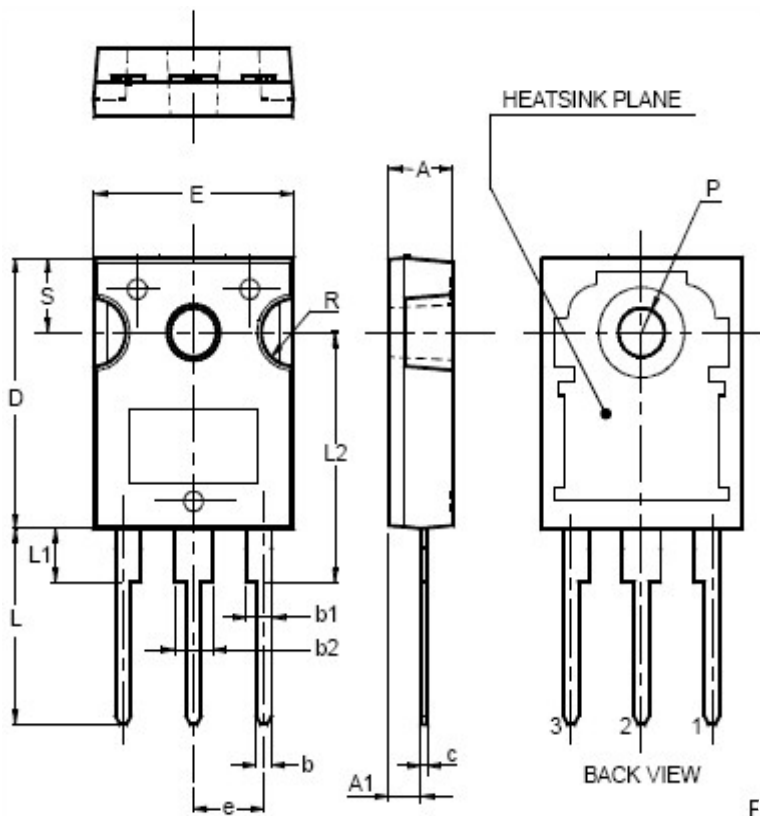

Ref.	mm		inch	
	MIN	MAX	MIN	MAX
A	4.85	5.15	0.190	0.200
A1	2.20	2.60	0.080	0.100
b	1.00	1.40	0.040	0.050
b1	2.00	2.40	0.070	0.090
b2	3.00	3.40	0.110	0.130
c	0.40	0.80	0.015	0.030
D	19.85	20.15	0.781	0.793
E	15.45	15.75	0.600	0.620
e	--	5.45	--	0.215
L	--	14.20	0.560	0.580
L1	3.70	4.30	0.140	0.170
L2	--	18.50	--	0.720
P	3.55	3.65	0.140	0.143
R	4.50	5.50	0.177	0.210
S	--	5.50	--	0.210

TUBE SHIPMENT INFORMATION

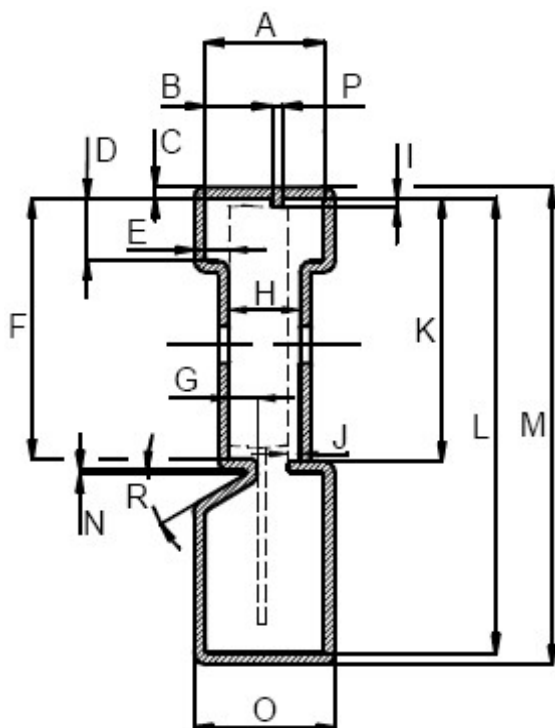

TUBE MECHANICAL DATA

Ref.	mm	inch
A	10.00 (±0.15)	0.394 (±0.006)
B	5.60	0.220
C	0.90 (±0.10)	0.035 (±0.004)
D	5.20	0.205
E	2.90 (±0.15)	0.114 (±0.006)
F	21.50 (±0.20)	0.846 (±0.008)
G	2.50 (+0 / -0.30)	0.098 (+0 / -0.012)
H	6.00 (±0.20)	0.236 (±0.008)
I	0.60	0.024
J	1.00	0.039
K	21.70 (+0 / -0.30)	0.854 (+0 / -0.012)
L	37.50 (±0.20)	1.476 (±0.008)
M	39.30	1.547
N	0.40	0.016
O	11.80	0.465
P	1.00	0.039
R	30°	30°

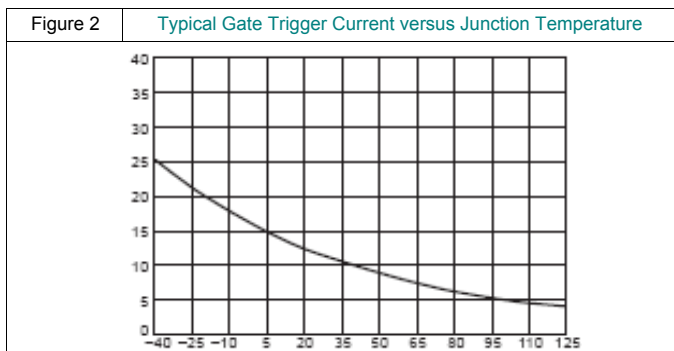
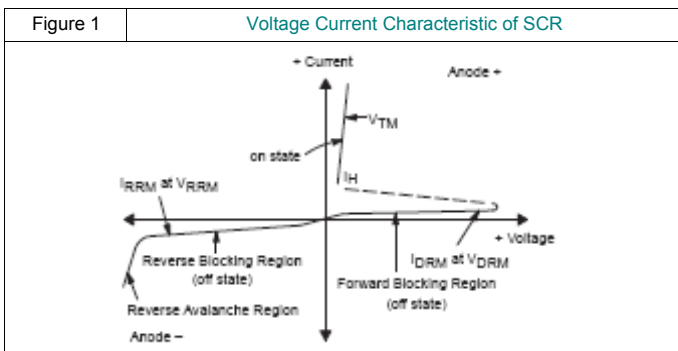

I_{GT} , GATE TRIGGER CURRENT(mA), T_J , JUNCTION TEMPERATURE (°C)

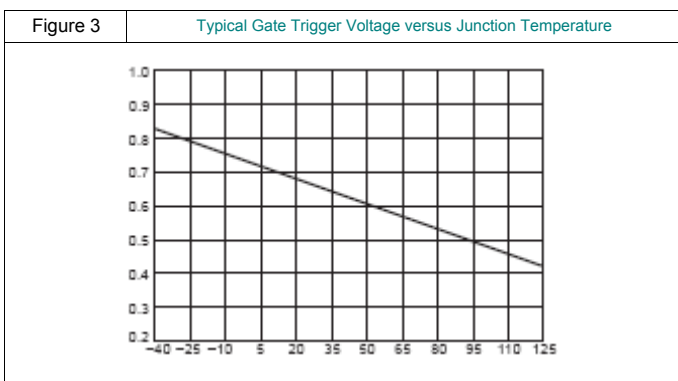

V_{GT} , GATE TRIGGER VOLTAGE(V); T_J , JUNCTION TEMPERATURE (°C)

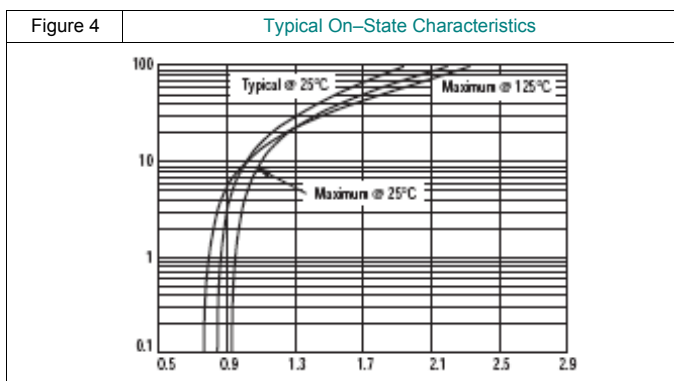

I_T , INSTANTANEOUS ON-STATE CURRENT(A); V_T , INSTANTANEOUS ON-STATE VOLTAGE(VOLTS)

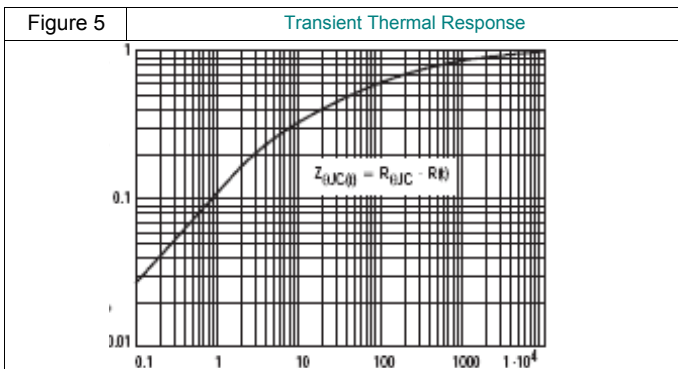

$R(t)$ TRANSIENT THERMAL R(NORMALIZED); t , TIME(ms)

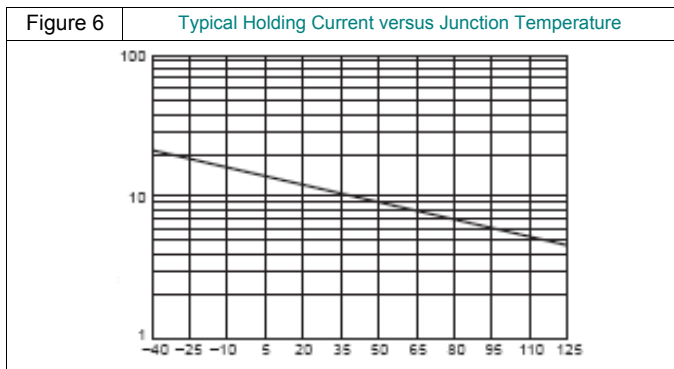

I_H , HOLDING CURRENT(mA); T_J , JUNCTION TEMPERATURE (°C)

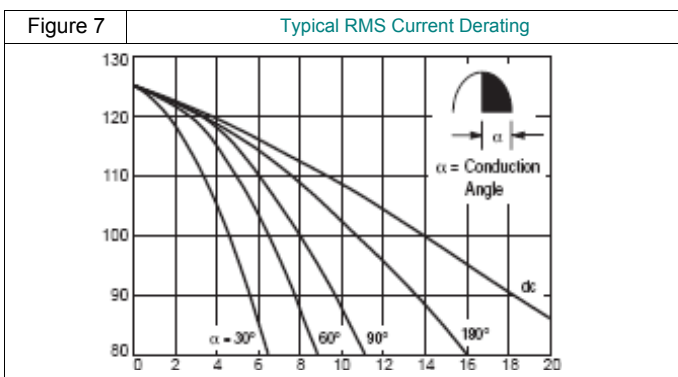

T_C , CASE TEMPERATURE(°C); $I_{T(RMS)}$, RMS ON-STATE CURRENT (AMPS)

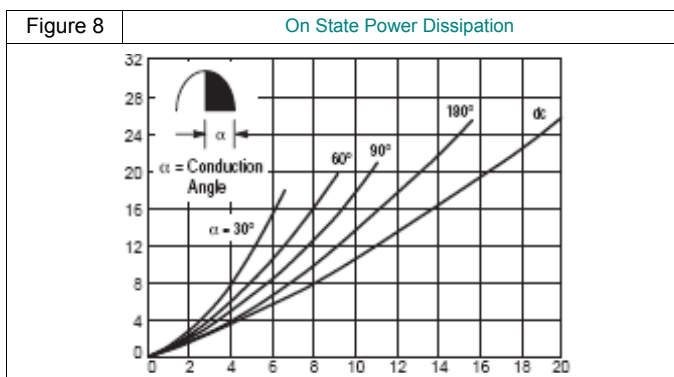

$P_{(AV)}$, AVERAGE POWER DISSIPATION(W); $I_{T(AV)}$, AVERAGE ON-STATE CURRENT(A)

版本信息

2011-12-01, KKG™ Product Data-V5.0

2014-05-22, KKG™ Product Data-V5.1



经中华人民共和国工商行政管理总局商标局批准

KKG 图案、字母、均为我公司正式注册商标，仿冒、盗用均属侵权，违法必究！

深圳市浩海電子有限公司

SHENZHEN HAOHAI ELECTRONICS CO., LTD.

2 floor(whole floor), BAOXIN Building. 0 Lane on the 8th. Yufeng Garden.
82 District. BAOAN District, Shenzhen City, Guangdong Province, China.

中國 廣東省 深圳市 寶安區 82区 裕豐花園 零巷8號 寶馨樓 二楼(全层)

公司电话 TEL: +86-755-29955080、29955081、29955082、29955083
总机八线 29955090、29955091、29955092、29955093

FAX: +86-755-27801767

E-mail: kkg@kkg.com.cn

产品主页 <http://www.szhhe.com>

<http://www.kkg.com.cn>