



General Description

The BF1005 is a high performance AC/DC on/off LED driver with four-stages dimming. It uses PFM method to build DCM fly-back power supplies. It operates in primary-side sensing and regulation while removing the need of secondary feedback circuitry. The device operates in PFM in CC mode and ON-OFF in CV mode.

The BF1005 has a four-stages dimming function. That means the output current will be adjusted to 100% when the first time power on corresponding to the first stage, 55% when the second time power on corresponding to the second stage, 25% when the third time power on corresponding to the third stage and 10% when the fourth time power on corresponding to the fourth stage. The cycle will restart to stage-one again when the fifth time power on. So this cycle will go on if the power off time is no more than 0.8 seconds.

Features

- 4 stages dimming function with ordinary switch
- Typical 5% output Current Accuracy
- Constant frequency start-up mode accelerate start-up process
- Eliminates Opto-coupler and TL431
- Built-in Short Circuit Protection, VDD Over Voltage Protection
- Cycle-by-Cycle Current Limiting
- VDD Under Voltage Lockout with Hysteresis (UVLO)
- Small SOT23-5 Package

Application

- LED lampion
- LED bulb (E14、 E27 etc)
- LED bedlamp

Typical Application

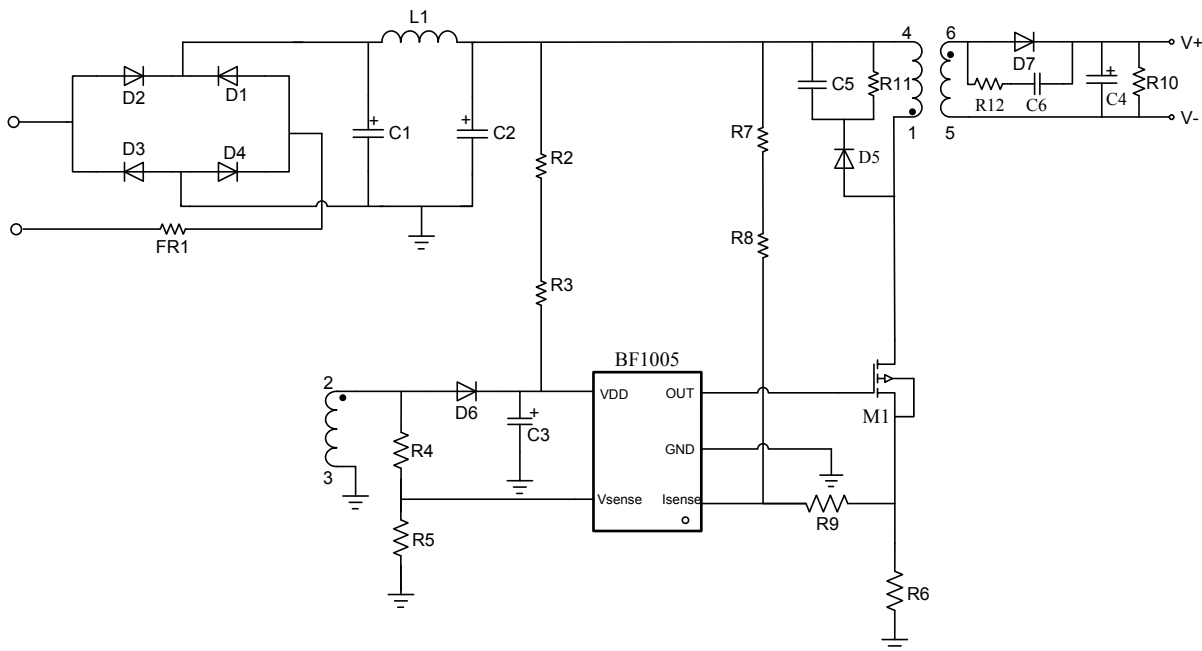

Block Diagram

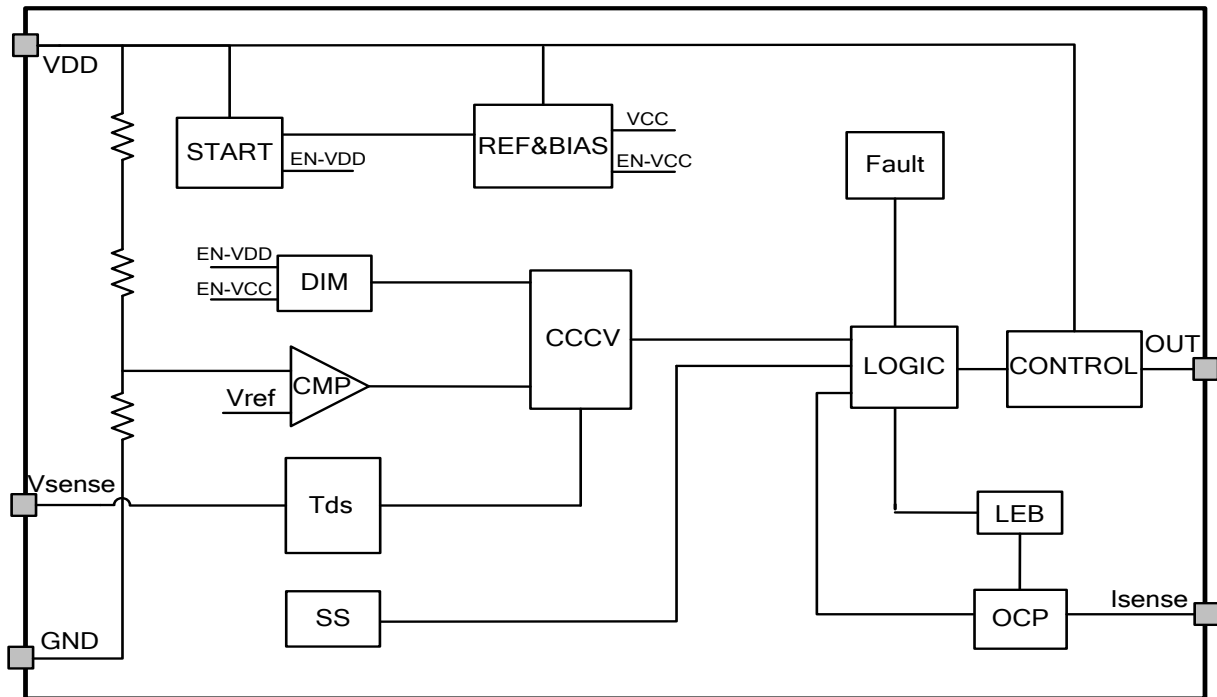

Package Type

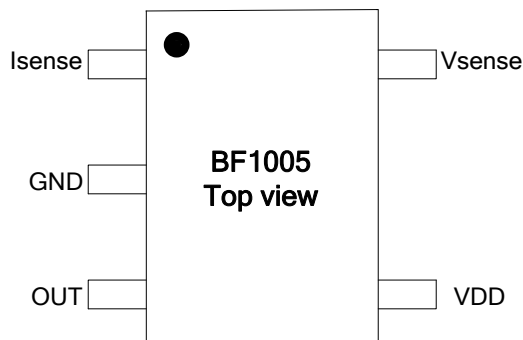

Pin Definition

Pin number	Pin name	Pin description
1	I sense	Current sense input.
2	GND	Ground.
3	OUT	Gate drive output for the external power MOS switch.
4	VDD	Power supply.
5	Vsense	Voltage sense input from the auxiliary winding.



Electrical Characteristic

(TA = 25°C, if not otherwise noted)

Parameter	Symbol	Test Conditions	Min.	Typ.	Max.	Unit
Supply Voltage						
Start-up Current	I _{dd}	VDD=14V	6	17	25	μA
Operation Voltage	V _{ov}			18		V
Operation Current	I _{oc}			250		uA
Turn-on Threshold Voltage	V _{ON}		14.5	16.5	18.5	V
Turn-off Threshold Voltage	V _{OFF}		9.5	11	12.5	V
CC/CV Mode Change Voltage	V _{cccv}		19.5	20.5	21.5	V
Oscillator						
Duty Cycle	T _{ds} /T		40	41	42	%
Current Sensing						
Leading Edge Blanking	T _{LEB}		300	400	500	ns
Maximum Current Sense Detection Voltage	V _{ocp_max}		1.18	1.20	1.22	V
Gate Driver Output						
Output Delay Time	T _d			150		ns
Output Rising Time	T _r	VDD=18V,CL=1nF		200		ns
Output falling Time	T _f	VDD=18V,CL=1nF		50		ns

Absolute Maximum Ratings

Item	Symbol	Value	Unit
VDD pin input voltage	VDD	40	V
Lead temperature	T _L	260	°C
SENSE pin input voltage	V _{SENSE} I _{SENSE}	7	V
Power Dissipation	P _D	400	mW
Operating Junction Temperature	T _J	-40 to +125	°C
Storage Temperature Range	T _{STJ}	-55 to +150	°C

Attention: Stresses beyond those listed under "absolute maximum ratings" may cause permanent damage to the device.

Exposure to absolute-maximum-rated conditions for extended periods may affect device reliability.

Operation Description

The BF1005 has inbuilt 4 stages dimming function without extra components and control signal input. It uses PFM with a constant factor between the demagnetization time and the operate cycle time to regulate the output current. Particular inductance compensation mode without more external components can achieve a high tight output current regulation.

● Start-up Current and Constant Frequency Start

The BF1005 is designed to have a low start-up current so that VDD can be charged up above the UVLO threshold and starts up quickly. After start-up, BF1005 will operate in a constant frequency (Typ.25KHz) until the output Voltage up to a certain value, so that the output can set up quickly.

● CC/CV Operation Mode

The switching frequency of BF1005 is adaptively controlled according to the load conditions and the operation modes. For flyback operating in DCM, the maximum output power is given by:

$$P_{out} = 0.5 * L_p * F_{sw} * I_p * I_p \quad (1)$$

(L_p : the inductance of primary winding; I_p : the peak current of primary winding)

Refer to the equation 1, the change of the primary winding inductance results in the change of the maximum output power and the constant output current in CC mode. To compensate the change from variations or primary winding inductance, the switching frequency is controlled by an internal loop, the relation is given by:

$$F_{sw} = 1 / (2 * T_{ds}) \quad (2)$$

(T_{ds} : The demagnetization time of secondary winding)

Since T_{ds} is proportional to the inductance, as a result, the product L_p and F_{sw} is constant, thus the maximum output power and constant current in CC mode will not change as primary winding inductance changes. The output current can be calculated by the following expressions:

$$I_{out} = 0.5 * \frac{T_{ds}}{T} * \frac{N_p}{N_s} * I_p \quad (3)$$

(N_p : Primary winding turns of the transformer; N_s : Secondary winding turns of the transformer.)

As the voltage of the VDD pin approaches to V_{ccv} from the CC operation mode, the power supply smoothly switches to operate in CV portion. During CV operation, the IC adjusts the MOS switching frequency to provide a constant output voltage. The output voltage can be calculated by the following expressions:

$$V_{out} = [(20.5 + VD6) * \frac{N_s}{N_a}] - VD7 \quad (4)$$

(N_s : Secondary winding turns of the transformer; N_a : Auxiliary winding turns of the transformer.)

● Switching dimming operation

The BF1005 gives a very convenient switching dimming function for user without extra components and control signal input. The users could turn on and off the input power to control the light intensity, shown as the V_{in} in the Figure1:

When the first time power on, R2/R3 will charge current to C3. As the VDD voltage rise, the register reset and the logic out is initialized. Then the circuit goes into normally working with output current of 100%(stage_1).when the power is off, and the power off time is less than 0.8seconds.If the power is on again, the logic output will change to the second stage and the output current will be 55%of output current(stage_2). So if you want to choose the third stage or the fourth stage, you should re-power on during the holding time (0.8 seconds). Then the cycle will go on and on.

If the power off time is more than 5 seconds, the circuit will be reset, and then the stage will go to the first stage.

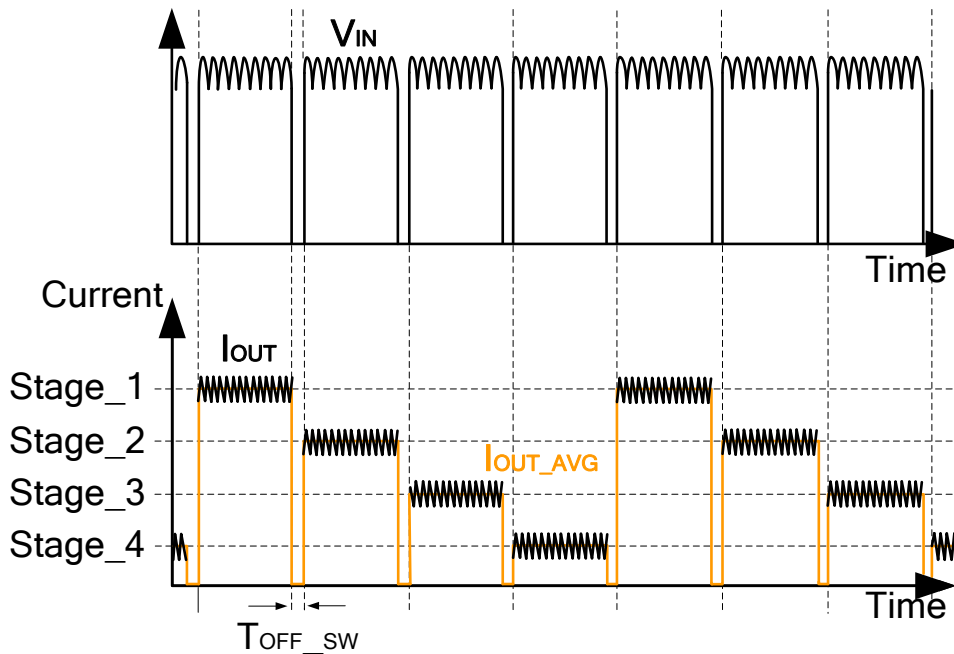

Figure1

- **Cycle-by-Cycle Current limit**

The current limit circuit senses the primary current from the voltage on the sensing resistor cycle by cycle. When the voltage exceeds the internal threshold, the power MOS will turn off immediately.

- **Voltage Protection Function**

The BF1005 includes such a function that protect against output over-voltage and under-voltage, which could be monitored by VDD pin. If the voltage at VDD pin exceeds the over-voltage threshold, the external power MOS will be turned off immediately and the controller will restart. Once VDD drops below the UVLO threshold, the controller will reset itself and go into a new start cycle. The controller will continue the start cycle until the error condition is removed.

Test Circuits

(1) Start-up current consumption (circuit 1)

Test Condition:

Connect Isense pin to ground, make the OUT pin floating and set $V2=0.8\pm0.03V$, $R1=10K\Omega$.

Test Method:

Set $V1=5\pm0.03V$ with 1ms delay time.

Keep $V1$ powered, increase $V1$ to $14\pm0.03V$, the current $A1$ flowing into VDD is the current consumption.

(2) Hysteresis start-up (circuit 1)

Test Condition:

Connect Isense pin to ground, make the OUT pin floating and set $V2=0.8\pm0.03V$, $R1=10K\Omega$.

Test Method:

Set $V1=5\pm0.03V$ with 1ms delay time.

When $V1$ increases over V_{X1} , the IC starts to work normally, and only when $V1$ decreases under V_{X2} , the IC stops working and moves into standby mode.

V_{X1} is the voltage $V1$ when the output (the OUT pin) frequency changes from $(0\pm0.2KHZ)$ to $(25\pm6KHZ)$.

V_{X2} is the voltage $V1$ when the output (the OUT pin) frequency changes from $(25\pm6KHZ)$ to $(0\pm0.2KHZ)$.

(3) Over current protection detection voltage (circuit 2)

Test Condition:

Make the OUT pin floating and set $V1=19\pm0.03V$, $V2=0.8\pm0.03V$, $R1=10K\Omega$.

Test Method:

Set $V3=0\pm0.03V$ with 1ms delay time.

The over current protection detection voltage is the voltage $V3$ when the output (the OUT pin) frequency changes from $(25\pm6KHZ)$ to $(0\pm0.2KHZ)$

(4) CC/CV mode transforming voltage (circuit 1)

Test Condition:

Connect Isense pin to ground, make the OUT pin floating and set $V2=0.8\pm0.03V$, $R1=10K\Omega$.

Test Method:

Set $V1=5\pm0.03V$ with 1ms delay time.

Keep $V1$ powered, increase $V1$ to $19\pm0.03V$, the IC starts to work normally, the output (the OUT pin) frequency changes from $(0\pm0.2KHZ)$ to $(25\pm6KHZ)$.

Then increase $V1$ to V_{CVX1} , the output (the OUT pin) frequency changes from $(25\pm6KHZ)$ to $(0\pm0.2KHZ)$.

V_{X1} is the CC/CV mode transforming voltage

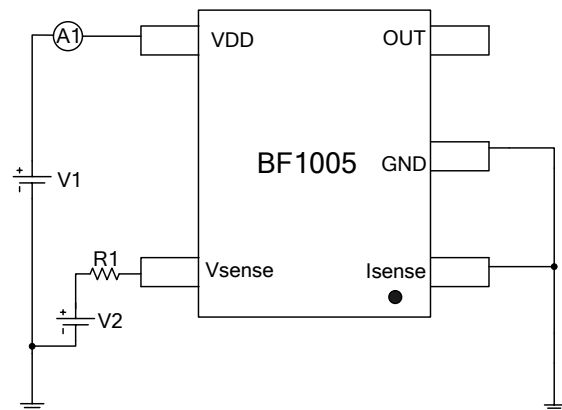

Circuit1: For testing current consumption, Hysteresis start-up

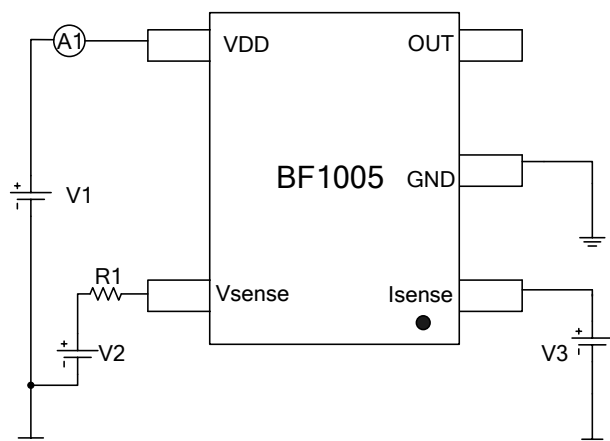

Circuit2: For over current protection detection

Package Outline

SOT23-5

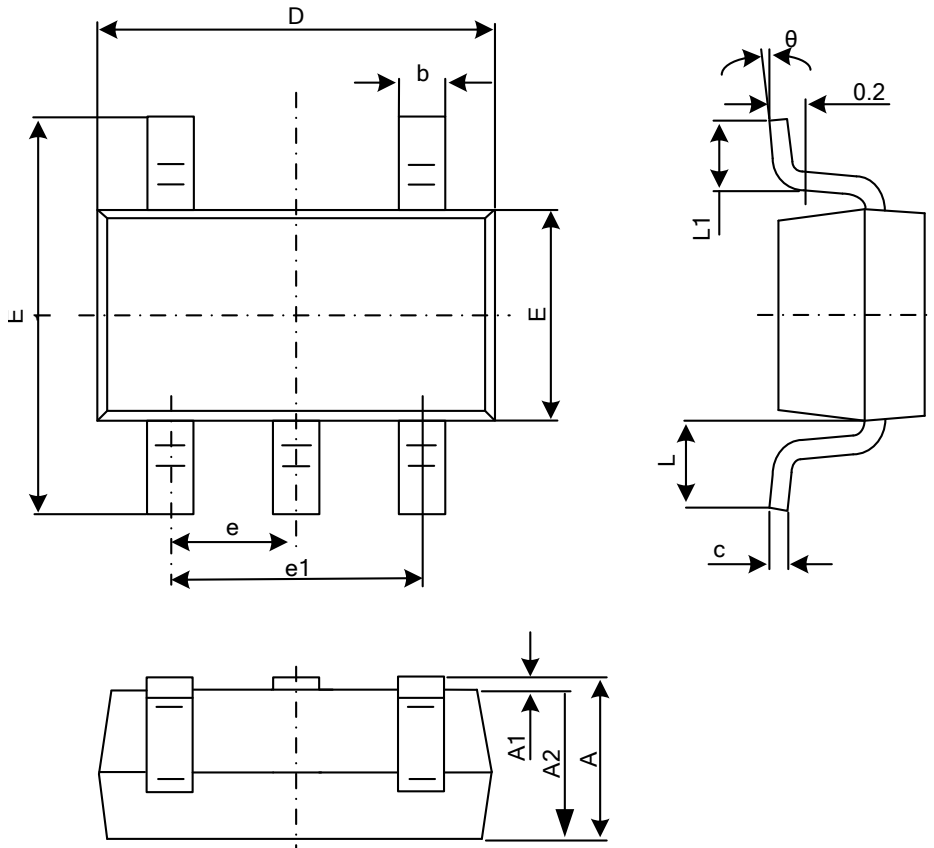

Symbol	Dimensions In Millimetres		Dimensions In Inches	
	Min	Max	Min	Max
A	1.050	1.250	0.041	0.049
A1	0.000	0.100	0.000	0.004
A2	1.050	1.150	0.041	0.045
b	0.300	0.400	0.012	0.016
c	0.100	0.200	0.004	0.008
D	2.820	3.020	0.111	0.119
E	1.500	1.700	0.059	0.067
E1	2.650	2.950	0.104	0.116
e	0.950TYP		0.037TYP	
e1	1.800	2.000	0.071	0.079
L	0.700REF		0.028REF	
L1	0.300	0.600	0.012	0.024
θ	0°	8°	0°	8°



RESTRICTIONS ON PRODUCT USE

- The information contained herein is subject to change without notice.
- BYD Microelectronics Co., Ltd. (short for BME) exerts the greatest possible effort to ensure high quality and reliability. Nevertheless, semiconductor devices in general can malfunction or fail due to their inherent electrical sensitivity and vulnerability to physical stress. It is the responsibility of the buyer, when utilizing BME products, to comply with the standards of safety in making a safe design for the entire system, including redundancy, fire-prevention measures, and malfunction prevention, to prevent any accidents, fires, or community damage that may ensue. In developing your designs, please ensure that BME products are used within specified operating ranges as set forth in the most recent BME products specifications.
- The BME products listed in this document are intended for usage in general electronics applications (computer, personal equipment, office equipment, measuring equipment, industrial robotics, domestic appliances, etc.). These BME products are neither intended nor warranted for usage in equipment that requires extraordinarily high quality and/or reliability or a malfunction or failure of which may cause loss of human life or bodily injury (“Unintended Usage”). Unintended Usage include atomic energy control instruments, airplane or spaceship instruments, transportation instruments, traffic signal instruments, combustion control instruments, medical instruments, all types of safety devices, etc.. Unintended Usage of BME products listed in this document shall be made at the customer’s own risk.