

# 500 万像素高拍仪模组

## 自动对焦规格书

### CAM Module Product Specifications

伟达科技有限公司 (Wedatech)——是一家港资高新技术企业，以摄像视讯应用为主业的方案设计公司，旗下有苏州研发中心与生产中心，深圳海瑞洋科技有限公司为其深圳子公司，伟达科技有十几年的摄像头应用技术经验，现自主研发高像素高清系列摄像头产品，物理像素从30万、100万、200万、500万、800万、900万等系列产品；高清产品主要有720P、1080P、高速720P、高速1080P、高清宽动态等系列产品；主要应用领域包含：高清视频会议专用摄像头系列产品、高拍仪摄像头方案系列产品、VTM/ATM 机专用摄像头系列产品、工业相机专用摄像头系列产品、笔记本电脑摄像头系列产品、3D 摄像头系列主板等高端方案产品。

高拍仪定焦产品系列为：

- USB2.0的200万像素定焦高拍仪模组 FF (SM-2M-0V01-FF)  
——固定焦距不用调节镜头；
- USB2.0的500万像素定焦高拍仪模组 FF (SM-5M-0V06-FF)  
——固定焦距不用调节镜头；
- USB3.0的800万像素定焦高拍仪模组 FF (SM-8M-0V01-FF)  
——固定焦距不用调节镜头；
- USB2.0的500万像素半自动对焦模组 MF (SM-5M-0V01-MF)  
——手动点击鼠标菜单进行对焦清晰；

高拍仪定焦产品系列为：

- USB2.0的500万像素自动对焦模组 AF (SM-5M-0V06-AF)  
(SM-5M-0V01-AF)  
——自动感应对焦最佳清晰度；
- USB3.0的800万像素自动对焦模组 AF (SM-8M-0V01-AF)  
——自动感应对焦最佳清晰度；

本规格书主要描述500万像素自动对焦高拍仪方案系列产品，



## **Contents:**

1. General Description
2. Feature
3. Pin Description
4. Outline Dimensions
5. Image Quality Specifications
6. Inspection Standard
7. Reliability Test
8. Application

## 1. General Description

### 1.1 Modules Described

This camera module is a USB2.0 Camera that designed for AF CAMERA. The backend IC and image sensor is adoption the M732 and T8EV5. It is fully compliant with the USB Video Class 1.1 standard. The dimension of the camera module is 58 ×29 ×6.0mm(L×W×H) (SM-5M-0V06-AF) , and 40 ×25×6.0mm(L×W×H) (SM-5M-0V01-AF) ;

## 2. Features

### 2.1 Sensor Specification

## key specifications

- active array size: 2592 x 1944
- power supply:
  - core: 1.5V ± 5% (with embedded 1.5V regulator)
  - analog: 2.6 ~ 3.0V (2.8V typical)
  - I/O: 1.8V / 2.8V
- power requirements:
  - active: TBD
  - standby: TBD
- temperature range:
  - operating: -30°C to 70°C (see table 8-1)
  - stable image: 0°C to 50°C (see table 8-1)
- output formats: 8-/10-bit RGB RAW output
- lens size: 1/4"
- lens chief ray angle: 24° (see figure 10-2)
- input clock frequency: 6~27 MHz
- S/N ratio: TBD
- dynamic range: TBD
- maximum image transfer rate:
  - QSXGA (2592x1944): 15 fps
  - 1080p: 30 fps
  - 1280x960: 45 fps
  - 720p: 60 fps
  - VGA (640x480): 90 fps
  - QVGA (320x240): 120 fps
- sensitivity: TBD
- shutter: rolling shutter / frame exposure
- maximum exposure interval: 1964 x t<sub>ROW</sub>
- pixel size: 1.4 μm x 1.4 μm
- well capacity: TBD
- dark current: TBD
- fixed pattern noise (FPN): TBD
- image area: 3673.6 μm x 2738.4 μm
- package dimensions: 5985 μm x 5835 μm

## 2.2 DSP Specification

The M732 is a USB 2.0 High-Speed (HS) compatible PC Camera controller. The superior image signal processing engine brings sight video experience. The high performance Motion-JPEG / compression engine makes variant compression ratio to satisfy bandwidth requirement. The compliant with USB Video Class . With the integrated sensor interface and color processing engine, it can support most available CMOS sensors that range from VGA to UXGA or HD..

M732 is controlled by the embedded micro-controller, and the statistics for 3A (AE / AWB / AF) are built-in. The flexible architecture consists of mask ROM, internal RAM and external serial-flash which can store the customized codes and parameters. With the highly-integrated firmware architecture and the developing kit provided ,it’ s easy for 3rd party to fulfill customized features..

Maximum Frame	XSGA	SXGA	VGA	CIF	QVGA	QCIF	QQVGA
Rate	2592x1944	1280x960	640x480	352x288	320x240	176x144	160x120
Non-compressed (YUY2)	2fps	25fps	30 fps	30 fps	60 fps	60 fps	60 fps
MJPEG	15fps	30fps	60fps	60fps	60fps	60fps	60fps

### 2.3.1 500万像素自动对焦高拍仪模组 AF ( SM-5M-OV06-AF )

#### 【产品描述】

- 1) 接口：USB2.0，兼容 USB1.1；
- 2) 像素：500 万
- 3) 感光尺寸：1/4”；
- 4) 板型：58 ×28 ×6.0mm(L×W×H).  
40×25 ×6.0mm(L×W×H).
- 5) 镜头参数：CONSTRUCTION: 5P 无畸变；  
For 1/4 Sensor;  
FOV 70°

- 6) 功能支持：线控、硬件拍照、录影等功能；
- 7) 捕获画面：2592x1944（拍照默认窗口）；
- 8) 输出格式：YUV2/RGB32 2fps/2592x1944；  
 MJPG 15fps/2592x1944；
- 9) 支持操作系统：Windows XP SP2、Vista、Windows7.0、Windows8.0、Windows8.1
- 10) 驱动方式：UVC 免驱；
- 11) 单帧捕获存储格式：BMP/JPG；
- 12) 动态捕获存储格式：AVI/WMV；
- 13) 适宜拍摄幅面：A4 纸张幅面、A3 纸张幅面；  
 （通过高拍仪外壳机构调节高度来实现）A4 纸张幅面；平行 A4 纸幅面到摄像头 PCB 的距离为：300mm; A3 幅面到摄像头感光芯片的镜头距离为：415mm;
- 14) 模组内容：含线控电路、拍照电路、晶振；
- 15) 高清晰度，全幅面覆盖，快速扫描拍照；
- 16) MIC：摄像头本身无麦克风功能,可以外加单独的模拟麦克风；
- 17) 工作温度：-30~75℃；
- 18) 功耗：<0.07W；

### 3. Pin Description

Number	Name	Pin Type	Description
Pin1	USB+5V	Power	Power Supply for module board
Pin2	USB D-	IO	USB differential signal
Pin3	USB D+	IO	USB differential signal
Pin4	USB GND	GND	Ground of module board

### 4.1 Outline Dimensions

Outline Dimension	58.0±0.2mm (W) x 24.0±0.2mm (L) x 6.0±0.2mm (H)
-------------------	---

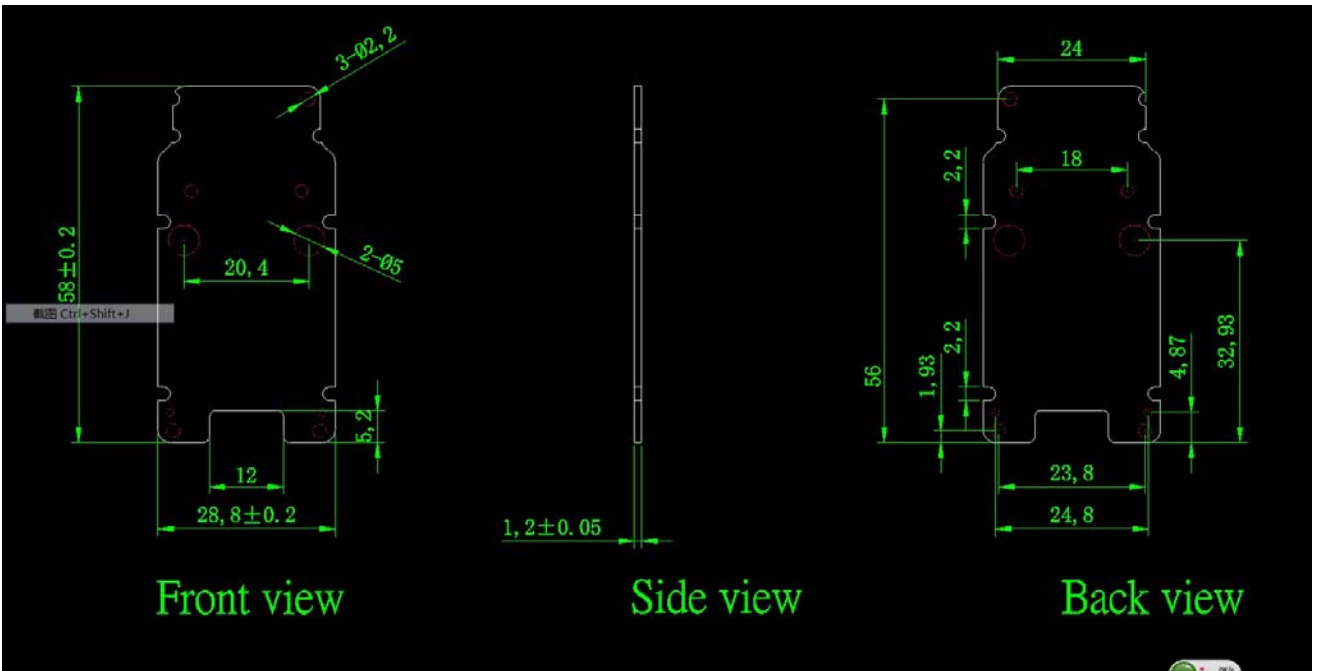
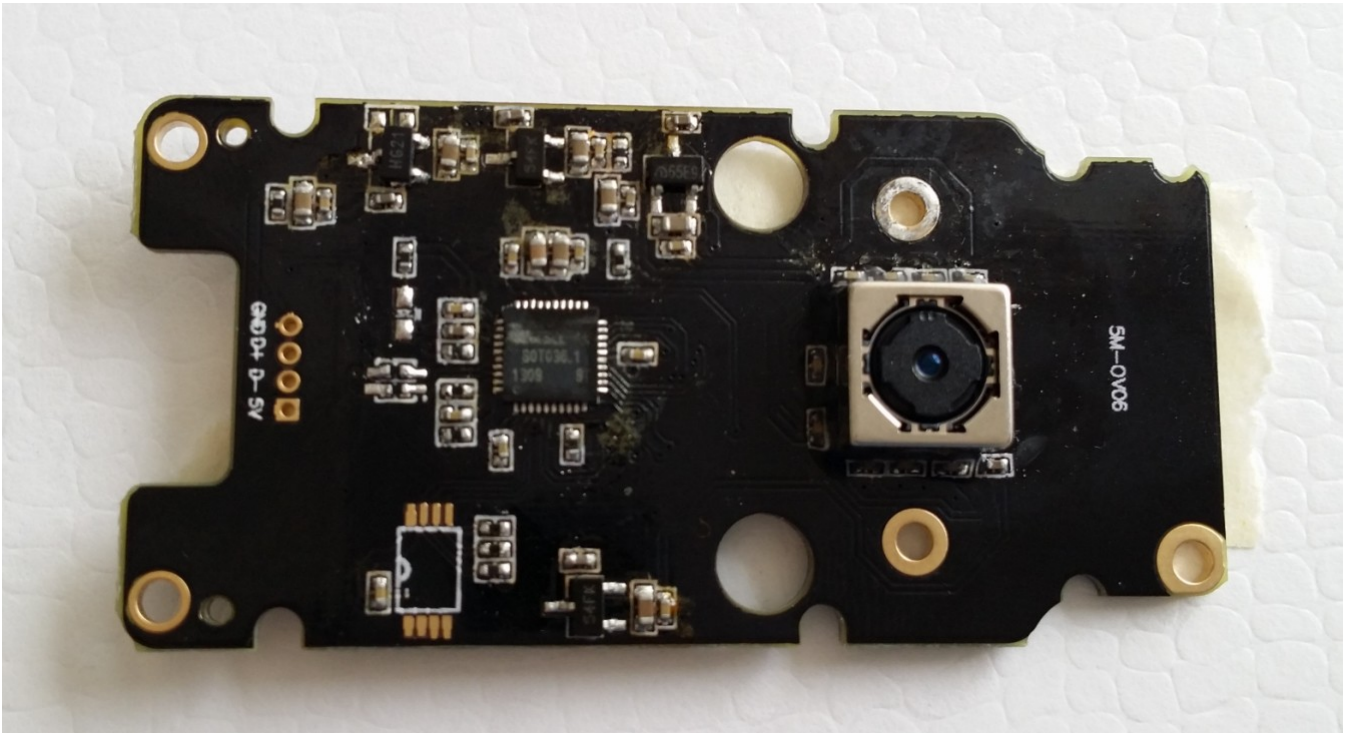

## 5. Image Quality Specifications

### 5.1 TEST Condition:

Environment luminance: Light Box, 500~800lux



Inspection distance: 45cm

Test chart: chart,500\*332,LP Width 1.05mm,Around 1.20mm

## 5.2 Image Quality Specifications

### 5.2.1 MTF

	Middle	UL	UR	BL	BR
Spec	450	400	400	400	400

### 5.2.2 Color/Gray/Noise

ColorAverageDeltaE	GrayLevel	NoiseBlock0_B	NoiseBlock0_G	NoiseBlock0_R
≤40	≥6	≤30	≤30	≤30

### 5.2.3 Blemish

There should be no blemish.

### 5.2.4 Wound Pixel

Dead and Wound Pixel criteria

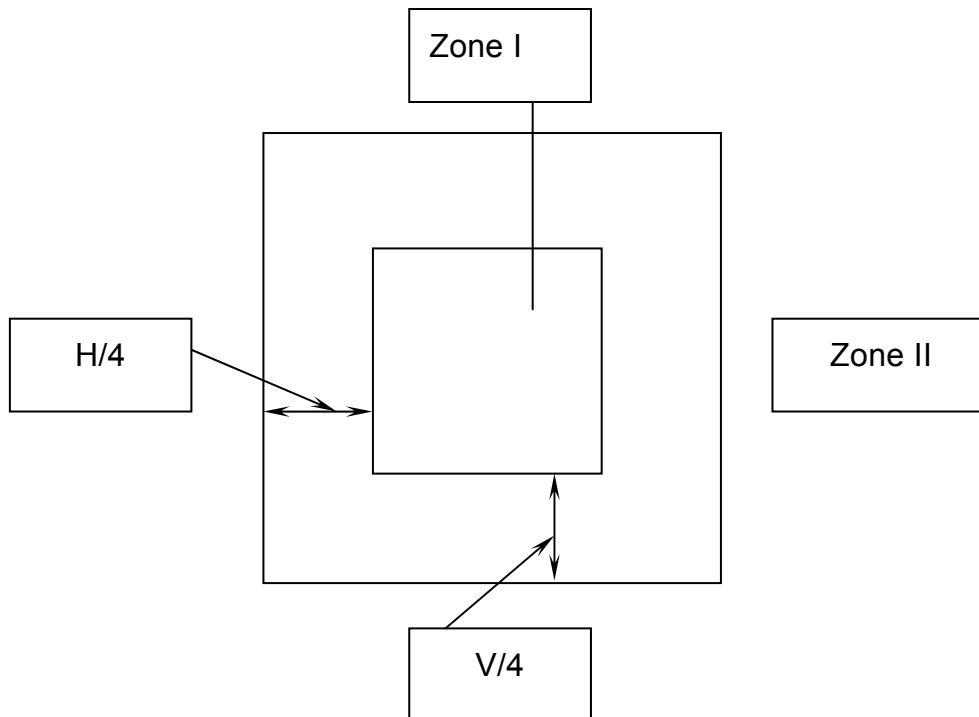

Zone definition: See diagram above

Table A1: Table of Grading(Under Bright Condition)

Grade	Dead Pixels		Wound pixels		Small Wound Clusters
	Zone I	Zone II	Zone I	Zone II	Zone I+ Zone II
A	2	8	4	32	≤8

Table A2: Table of Grading(Under Dark Field)

Grade	Dead Pixels		Wound pixels		Small Wound Clusters
	Zone I	Zone II	Zone I	Zone II	Zone I+ Zone II
A	2	8	4	32	<=8

**Dead pixels** include black pixel and bright pixel.

**Black Pixels** are more than 30% darker than the normal mean pixel are labeled as black pixels.

**Bright Pixels** are more than 30% brighter than the normal mean pixel are labeled as bright pixels.

**Wound Pixel** is between 14% and 30% darker or brighter than mean pixel.

**A small wound cluster** is defined as 1x1 to 2x2 wound pixel size in RGB raw data output and for YUV outputs are defined as 2x2 to 4x4 wound pixel size.

### 5.2.5 Shading

Each Corner compares with the Center  $\geq 50\%$

## 6. Inspection Standard

### 6.1 Sampling Plan

Follows up MIL-STD-105E LEVEL II single and Normal plan

**Major AQL=0.65 ; Minor AQL=1.5**

### 6.2 Inspection Items and Process

#### 6.2.1 Visual Inspection

Visual inspection need to be done under illuminant 500 ~ 600 lux, Puts the sample around 30 cm far from inspector, checks it from 0 ~ 60 degree to each side at least 5 second by following the sequence from UP to DOWN, then, LEFT to RIGHT by screening.

Dimensions measuring must use a Vernier and/or an Altimeter.

#### 6.2.2 Checking list

Inspection Items	Criteria	Defect	
		Maj.	Min.
Label or Mark	Model name, Part number and Quantity must be filled in correctly.	V	
Anti-Static packing	1. A desiccative must put into Bag. 2. Must be a vacuum-packed after		V

	Sealed bag off.		
PCB surface	Not allow to see serious scratched, excess glue or broken	V	
Lens surface	Must be fixed well by glue		V
Lens joint	Not allows to excess glue over the width of Lens Holder.		V
Total Height from Lens to PCB surface.	6±0.2 MM	V	
Connector	Not allow scratch and dirty	V	
Width of Module	14.0±0.2 MM	V	
Joint of Lens Holder and PCB	Must be firmed, not allows to see gap or warp.	V	
Image Function(Bad Pixel, Wound Pixel Dark, Shut-down, Resolution and Blemish)	Must be according to Image quality specification	V	

Remark:

1. Serious Scratch: Copper or metal should be covered by painting/ coating clear to see caused by Scratch.
2. Slight scratch: Copper or metal under coating / painting can not be seen.

## 7. Reliability Test

### 7.1 Test element

Each test should use a new module unless specified.

### 7.2 Test Schedule

Qualification: During the product development and before the mass production  
 Maintenance: when a design change can influence the function test and when the production place is changed.

### Vibration Test

Procedure	The Camera Module device is to be tested for all three axes, whereby a new device should be used for each axis. During the test no device part must loosen or disconnect.
-----------	---

Test parameters	Set on a dummy set(100g), then test according to the condition listed below test condition: Frequency range: 5 ~ 500 Hz G value: 3 G-rms Direction: X, Y and Z-axis Duration: 15 minutes for each axis
Procedure after test / Requirement:	Visual inspection: No loose parts, no evidence of any damage! Functionality test: Full functionality of the Camera Module must be verified.

### Drop Test

Purpose	Checks the robustness of the Camera Module against drop.
Scope of testing:	Set on a dummy set(100g) drop from 150 cm Each 6 planes for twice. Notice that the material of the dummy set is wood.
Product requirements:	The function of the device may not be affected or impaired in any way. There may be no loose parts inside/on the test device.

### Thermal Shock

Purpose:	Checks the resistance of the Camera Module against a change of the temperature. Mode of operation: Camera Module disconnected.
Test parameters:	Place test samples in Temperature Shock Chamber for 24 cycles (24 hours) at -40°C for 30min, then +85°C for 30min, each cycle test are 1 hour.
Procedure after test / Requirement:	•Visual inspection: No physical change. Slight dew formation is permissible. •Functionality test after the camera has returned to ambient temperature for 24hr. Full functionality of the camera must be verified.

### High Temperature and Humidity Storage

Purpose:	Checks the resistance of the Camera Module in a high temperature and high humidity environment. Mode of operation: Camera Module disconnected.
Test parameters:	Place test samples in Thermal/Humidity Chamber set at 65°C/90%RH, 48hrs.
Procedure after test / Requirement:	• Visual inspection: No physical change. • Functionality test after the camera has returned to ambient temperature: Full functionality of the camera must be verified.

### Low Temperature Storage

Purpose:	Checks the resistance of the Camera Module in a low temperature environment. Mode of operation: Camera Module disconnected.
Test parameters:	Place test samples in Thermal Chamber set at -30°C, 48hrs.
Procedure after test / Requirement:	<ul style="list-style-type: none"> <li>• Visual inspection: No physical change.</li> <li>• Functionality test after the camera has returned to ambient temperature: Full functionality of the camera must be verified.</li> </ul>

### Connector Mating

Purpose:	Check the robustness of the Connector.
Test parameters:	<ul style="list-style-type: none"> <li>(1). Mating/Un-mating male &amp; female connector</li> <li>(2). Duration : 25 cycles</li> <li>(3). Function test every 5cycles</li> </ul>
Procedure after test / Requirement:	<ul style="list-style-type: none"> <li>•The function of the device may not be affected or impaired in anyway.</li> <li>•Visual inspection: No loose parts, no evidence of any damage.</li> </ul>

### 8、应用领域：

此产品为高拍仪主板，主要匹配给生产高拍仪产品工厂，

高拍仪应用领域：工厂企业、银行、金融系统、保险公司、社保局、档案局、医院、学校等；