

ALS30 Series 85°C

RoHS
Compliant

- Compact size
- Long life, 20000 hours at 85°C (U_r, I_r applied)
- High ripple current
- Excellent surge voltage capability
- Optimized designs available on request

APPLICATION

Smoothing, energy storage, or pulse operation in telecommunication demanding power supplies, process control, AC-motor control, traction, welding and measuring.

BASIC DESIGN

The ALS30/31 series of screw terminal capacitors cover a wide range of case sizes and voltage ratings featuring high ripple currents and long life performance. They are ideally suited for industrial and

commercial applications demanding high reliability and long life expectancy such as frequency converters, UPS systems and switch mode power supplies.

SPECIFICATION

Standards	IEC 60384-4 Long Life Grade 40/85/56,																	
Capacitance range	100 – 680000 µF																	
Capacitance tolerance	-20 to +20%																	
Rated voltage U_R	25–500 VDC																	
Surge voltage U_S	1.15 x U _R (for U _R ≤ 250 VDC) 1.10 x U _R (for U _R ≥ 350 VDC)	Test Condition: ≤ 30s surge, 1000 cycles @ 85°C																
Surge voltage U_{SS} (Short duration)	<table border="1"> <tr> <th>U_R</th> <th>U_{SS}</th> </tr> <tr> <td>200</td> <td>350</td> </tr> <tr> <td>250</td> <td>400</td> </tr> <tr> <td>350</td> <td>500</td> </tr> <tr> <td>400</td> <td>520</td> </tr> <tr> <td>415</td> <td>530</td> </tr> <tr> <td>450</td> <td>550</td> </tr> <tr> <td>500</td> <td>600</td> </tr> </table>	U _R	U _{SS}	200	350	250	400	350	500	400	520	415	530	450	550	500	600	Test Condition: ≤ 500ms surge, 100 cycles @ 20°C
U _R	U _{SS}																	
200	350																	
250	400																	
350	500																	
400	520																	
415	530																	
450	550																	
500	600																	
Leakage current I_L	= 0.006 x C _R x U _R (µA) or 6mA whichever is the smaller. Note, C _R is in µF.	Test Condition: U _R , 5mins., 20°C																
Operational life time +85°C, U_R, I_R	<table border="1"> <tr> <th>Can Diameter</th> <th>Life (hrs)</th> </tr> <tr> <td>36</td> <td>11000</td> </tr> <tr> <td>51</td> <td>18000</td> </tr> <tr> <td>66</td> <td>19000</td> </tr> <tr> <td>77, 90</td> <td>20000</td> </tr> </table>	Can Diameter	Life (hrs)	36	11000	51	18000	66	19000	77, 90	20000	End of Life requirement: $\Delta C/C \leq \pm 10\%$ $ESR \leq 2 \times \text{initial ESR value}$ $I_L \leq \text{initial specified limit}$						
Can Diameter	Life (hrs)																	
36	11000																	
51	18000																	
66	19000																	
77, 90	20000																	
+85°C, U_R	<table border="1"> <tr> <th>Can Diameter</th> <th>Life (hrs)</th> </tr> <tr> <td>36</td> <td>22000</td> </tr> <tr> <td>51</td> <td>36000</td> </tr> <tr> <td>66</td> <td>38000</td> </tr> <tr> <td>77, 90</td> <td>40000</td> </tr> </table>	Can Diameter	Life (hrs)	36	22000	51	36000	66	38000	77, 90	40000							
Can Diameter	Life (hrs)																	
36	22000																	
51	36000																	
66	38000																	
77, 90	40000																	
Shelf Life	2000 hrs at 0V +85°C, or 30000 hrs at 0V +40°C																	
Temperature range	-40 to +85°C (Operating) -55°C to +85°C (Storage)																	

SPECIFICATION

Terminal styles A, R

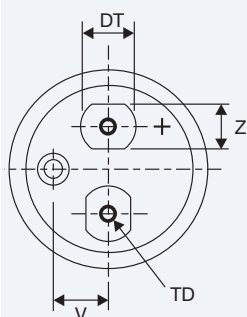

Fig. 1

Terminal styles A (ø36mm only), C, G, J, M

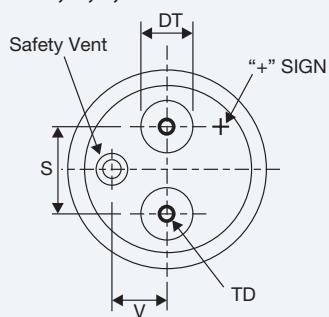
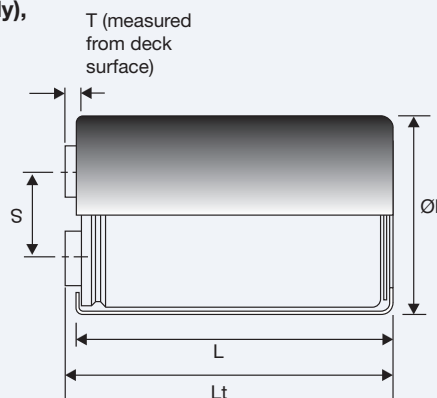
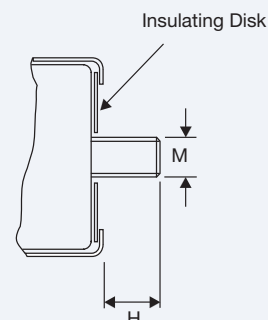

Fig. 2



**ALS30
Clamp Mounting**



**ALS31
Stud Mounting**

Case Polarity

Due to the presence of electrolyte in the capacitor the aluminium can and stud mounting will essentially be at the same polarity as the negative terminal. We recommend that the stud and can are insulated (see accessories for insulating nuts).

Terminals options

* preferred options in bold

Term. Style	Thread	Height T - mm ±0.5	Dia. - DT mm ±0.5	Thread depth TD - mm minimum	Drawing
A*	M5	5.5	13	10	Fig.1 Z=10mm
A*	M5	7.14	8	10	Fig.2 ø36mm only
C	M6	5.5	13	10	Fig.2
G	M6	6.35	17	11.8	Fig.2
J	M6	3.17	17	8.8	Fig.2
M	M5	7.14	8	10	Fig.2
R	M5	5.5	15	10	Fig.1 Z=13mm

Terminations

Aluminium inserts with M5 threads as standard, max. torque 2NM. Optional M6 threaded inserts have a max. torque 4NM. Max. torque for stud mounting M8:4NM and M12:8NM.

Dimensions table ALS30 (sleeved) mm

Case Code	D ±1	L ±2	Lt* ±1	S ±0.5	T ±0.5	V mm	M THREAD	H ±1	MOUNTING CLIP	WEIGHT grams nom.	Terminal Style
											A C G J M R
DA	36	52	58.5	12.8	7.14	8	M8	12	V3/H2/UTE2736	75	•
DB	36	62	67.5	12.8	7.14	8	M8	12	V3/H2/UTE2736	90	•
DE	36	82	87.5	12.8	7.14	8	M8	12	V3/H2/UTE2736	115	•
DF	36	105	111.5	12.8	7.14	8	M8	12	V3/H2/UTE2736	140	•
KE	51	82	86.5	22.2	5.5	13.7	M12	16	V4/UTE2737	220	•
KF	51	105	110.5	22.2	5.5	13.7	M12	16	V4/UTE2737	300	•
MF	66	105	110.5	28.5	5.5	15.8	M12	16	V10/UTE2738	505	• •
ND	77	75	79.5	31.8	5.5	19	M12	16	V11	495	• • • • • •
NF	77	105	110.5	31.8	5.5	19	M12	16	V11	690	• • • • • •
NP	77	146	150.5	31.8	5.5	19	M12	16	V11	960	• • • • • •
NT	77	220	224.5	31.8	5.5	19	M12	16	V11	1450	• • • • • •
QC	90	67	71.5	31.8	5.5	25	M12	16	V90	615	• • •
QD	90	75	79.5	31.8	5.5	25	M12	16	V90	690	• • •
QH	90	98	103.5	31.8	5.5	25	M12	16	V90	900	• • •
QP	90	146	149.5	31.8	5.5	25	M12	16	V90	1345	• • •
QT	90	220	223.5	31.8	5.5	25	M12	16	V90	2000	• • •

* Dimensions Lt will change dependant on terminal style.

ARTICLE TABLE ALS30 (85°C)

Cap (μ F)	Case Size (mm)	ESR (m Ω) at 20°C 100Hz (max)	Impedance (m Ω) at 20°C 10 KHz (max)	Ripple current(A) at 85°C		Type number
				100 Hz	10 KHz	
25 VDC (U_R)						
15000	36x52	24	20	8.2	8.7	ALS3 -- 153DA025
22000	36x62	17	15	9.9	10.4	ALS3 -- 223DB025
33000	36x82	11	10	13.2	13.9	ALS3 -- 333DE025
47000	36x105	9	7	16.6	17.4	ALS3 -- 473DF025
68000	51x82	11	10	15.6	16.9	ALS3 -- 683KE025
100000	51x105	9	8	19.6	20.6	ALS3 -- 104KF025
150000	77x75	11	11	17.9	18.1	ALS3 -- 154ND025
150000	66x105	6	6	28.4	28.9	ALS3 -- 154MF025
220000	90x67	9	8	21.9	22.6	ALS3 -- 224QC025
220000	90x75	12	12	18.7	18.8	ALS3 -- 224QD025
220000	77x105	6	6	28.1	30.8	ALS3 -- 224NF025
330000	90x98	8	8	26.4	26.5	ALS3 -- 334QH025
330000	77x146	5	5	37.3	39.6	ALS3 -- 334NP025
470000	90x146	4	4	43.6	43.9	ALS3 -- 474QP025
470000	77x220	4	4	45.8	47.0	ALS3 -- 474NT025
680000	90x220	4	4	55.4	56.7	ALS3 -- 684QT025
40 VDC (U_R)						
10000	36x52	23	20	7.9	8.4	ALS3 -- 103DA040
15000	36x62	17	14	9.5	10.0	ALS3 -- 153DB040
22000	36x82	11	10	12.7	13.3	ALS3 -- 223DE040
33000	51x82	12	11	14.2	16.7	ALS3 -- 333KE040
47000	51x82	12	11	14.2	16.7	ALS3 -- 473KE040
68000	51x105	10	9	18.0	20.6	ALS3 -- 683KF040
100000	77x75	13	12	16.4	16.5	ALS3 -- 104ND040
100000	66x105	7	6	26.3	26.6	ALS3 -- 104MF040
100000	90x67	8	7	23.0	24.8	ALS3 -- 104QC040
100000	90x75	10	10	20.3	20.4	ALS3 -- 104QD040
150000	77x105	8	8	26.8	30.2	ALS3 -- 154NF040
150000	90x98	7	7	28.6	28.9	ALS3 -- 154QH040
220000	77x146	6	5	35.4	39.6	ALS3 -- 224NP040
220000	90x146	4	4	46.5	47.0	ALS3 -- 224QP040
330000	77x220	4	4	45.0	46.5	ALS3 -- 334NT040
470000	90x220	4	4	52.3	53.4	ALS3 -- 474QT040
63 VDC (U_R)						
4700	36x52	36	28	6.7	7.4	ALS3 -- 472DA063
6800	36x62	26	20	8.2	9.0	ALS3 -- 682DB063
10000	36x82	17	14	10.8	11.9	ALS3 -- 103DE063
15000	36x105	15	8	10.9	14.4	ALS3 -- 153DF063
15000	51x82	12	11	13.9	14.4	ALS3 -- 153KE063
22000	51x82	12	11	13.9	14.4	ALS3 -- 223KE063
33000	51x105	10	9	17.4	18.0	ALS3 -- 333KF063
47000	77x75	13	13	16.6	16.8	ALS3 -- 473ND063
47000	66x105	8	7	26.7	26.5	ALS3 -- 473MF063
47000	90x75	11	10	20.3	20.7	ALS3 -- 473QD063
68000	90x67	10	9	20.9	22.4	ALS3 -- 683QC063
68000	77x105	8	8	24.7	26.4	ALS3 -- 683NF063
68000	90x98	8	7	28.9	29.6	ALS3 -- 683QH063
100000	77x146	6	6	34.8	35.4	ALS3 -- 104NP063
150000	90x146	5	5	40.2	40.7	ALS3 -- 154QP063
150000	77x220	4	4	43.3	45.1	ALS3 -- 154NT063
220000	90x220	4	4	52.4	54.3	ALS3 -- 224QT063

Mounting Style 0=plain or 1=stud 
Termination Style A,C,G,J,M or R 

ARTICLE TABLE ALS30 (85°C)

Cap (μ F)	Case Size (mm)	ESR ($m\Omega$) at 20°C 100Hz (max)	Impedance ($m\Omega$) at 20°C 10 KHz (max)	Ripple current(A) at 85°C		Type number
				100 Hz	10 KHz	
100 VDC (U_R)						
2200	36x52	69	55	4.9	5.4	ALS3 -- 222DA100
3300	36x62	49	39	6.0	6.6	ALS3 -- 332DB100
4700	36x82	33	27	7.9	8.8	ALS3 -- 472DE100
6800	36x105	23	19	10.0	11.1	ALS3 -- 682DF100
10000	51x82	28	24	10.1	10.5	ALS3 -- 103KE100
15000	51x105	20	18	12.6	13.1	ALS3 -- 153KF100
22000	77x75	25	24	12.0	12.2	ALS3 -- 223ND100
22000	66x105	13	12	18.4	19.1	ALS3 -- 223MF100
22000	90x67	15	13	18.9	20.9	ALS3 -- 223QC100
22000	90x75	21	20	14.7	15.0	ALS3 -- 223QD100
33000	77x105	15	14	17.6	19.0	ALS3 -- 333NF100
33000	90x98	13	12	20.8	21.2	ALS3 -- 333QH100
47000	77x146	10	9	25.2	25.7	ALS3 -- 473NP100
68000	90x146	9	8	29.4	29.8	ALS3 -- 683QP100
68000	77x220	7	6	40.6	41.5	ALS3 -- 683NT100
100000	90x220	6	5	30.8	33.3	ALS3 -- 104QT100
200 VDC (U_R)						
470	36x52	286	227	2.6	4.3	ALS3 -- 471DA200
680	36x62	199	158	3.9	5.4	ALS3 -- 681DB200
1000	36x82	135	107	5.1	7.1	ALS3 -- 102DE200
1500	36x105	90	72	5.6	9.1	ALS3 -- 152DF200
2200	51x82	73	60	8.2	9.7	ALS3 -- 222KE200
3300	51x105	48	40	9.2	13.1	ALS3 -- 332KF200
4700	77x75	48	42	10.6	11.5	ALS3 -- 472ND200
4700	66x105	33	27	13.0	19.1	ALS3 -- 472MF200
6800	66x105	27	23	15.7	17.7	ALS3 -- 682MF200
6800	90x67	38	29	13.7	18.5	ALS3 -- 682QC200
6800	90x75	35	31	13.3	14.3	ALS3 -- 682QD200
10000	77x105	28	25	14.9	15.9	ALS3 -- 103NF200
10000	90x98	23	20	18.8	20.3	ALS3 -- 103QH200
15000	77x146	18	16	21.4	22.7	ALS3 -- 153NP200
22000	90x146	13	12	26.7	28.0	ALS3 -- 223QP200
22000	77x220	11	9	36.1	38.7	ALS3 -- 223NT200
33000	90x220	10	9	42.2	44.8	ALS3 -- 333QT200
250 VDC (U_R)						
470	36x52	247	187	3.0	4.5	ALS3 -- 471DA250
680	36x62	172	131	3.8	5.6	ALS3 -- 681DB250
1000	36x82	117	89	5.0	7.4	ALS3 -- 102DE250
1500	51x82	86	67	6.2	9.8	ALS3 -- 152KE250
2200	51x82	69	55	7.7	9.1	ALS3 -- 222KE250
3300	51x105	45	36	10.4	12.4	ALS3 -- 332KF250
3300	77x75	52	43	10.4	11.9	ALS3 -- 332ND250
4700	66x105	31	24	15.0	18.2	ALS3 -- 472MF250
4700	90x75	38	32	13.2	14.9	ALS3 -- 472QD250
6800	90x67	35	27	13.5	17.7	ALS3 -- 682QC250
6800	77x105	29	25	15.0	16.5	ALS3 -- 682NF250
10000	90x98	24	21	17.1	18.4	ALS3 -- 103QH250
10000	77x146	19	16	21.6	24.0	ALS3 -- 103NP250
15000	90x146	14	12	27.0	29.5	ALS3 -- 153QP250
15000	77x220	12	10	32.4	36.5	ALS3 -- 153NT250
22000	77x220	9	7	36.3	45.8	ALS3 -- 223NT250
22000	90x220	12	10	42.3	47.4	ALS3 -- 223QT250

Mounting Style 0=plain or 1=stud 
Termination Style A,C,G,J,M or R 

ARTICLE TABLE ALS30 (85°C)

Cap (μ F)	Case Size (mm)	ESR ($m\Omega$) at 20°C 100Hz (max)	Impedance ($m\Omega$) at 20°C 10 KHz (max)	Ripple current(A) at 85°C		Type number
				100 Hz	10 KHz	
350 VDC (U_R)						
330	36x52	325	226	2.4	5.0	ALS3 -- 331DA350
470	36x82	223	154	3.4	7.2	ALS3 -- 471DE350
680	36x105	154	107	4.4	9.0	ALS3 -- 681DF350
1000	51x82	116	82	6.1	10.6	ALS3 -- 102KE350
1500	51x105	77	55	8.2	13.5	ALS3 -- 152KF350
2200	51x105	66	48	8.7	14.1	ALS3 -- 222KF350
2200	77x75	66	50	9.1	15.6	ALS3 -- 222ND350
2200	66x105	52	37	11.9	19.3	ALS3 -- 222MF350
3300	66x105	39	29	12.8	20.3	ALS3 -- 332MF350
3300	90x67	49	34	11.8	18.0	ALS3 -- 332QC350
3300	90x75	47	36	12.5	19.8	ALS3 -- 332QD350
4700	77x105	35	27	14.7	21.7	ALS3 -- 472NF350
4700	90x98	31	24	16.3	26.6	ALS3 -- 472QH350
6800	77x146	23	18	19.3	26.0	ALS3 -- 682NP350
6800	90x146	20	15	24.9	34.4	ALS3 -- 682QP350
10000	77x220	15	11	31.7	39.3	ALS3 -- 103NT350
15000	90x220	15	12	38.2	46.4	ALS3 -- 153QT350
400 VDC (U_R)						
220	36x52	570	387	2.1	4.4	ALS3 -- 221DA400
330	36x62	382	260	2.7	5.5	ALS3 -- 331DB400
470	36x82	267	182	3.5	7.1	ALS3 -- 471DE400
680	36x105	185	126	4.4	8.8	ALS3 -- 681DF400
1000	51x82	139	98	5.8	10.3	ALS3 -- 102KE400
1500	51x105	92	65	7.8	13.1	ALS3 -- 152KF400
1500	77x75	97	70	8.3	14.7	ALS3 -- 152ND400
2200	51x105	78	56	8.4	13.5	ALS3 -- 222KF400
2200	66x105	62	44	11.2	18.8	ALS3 -- 222MF400
2200	90x75	69	50	10.7	18.9	ALS3 -- 222QD400
3300	90x67	53	38	11.7	17.1	ALS3 -- 332QC400
3300	77x105	49	36	13.4	21.3	ALS3 -- 332NF400
3300	90x98	45	32	14.9	25.3	ALS3 -- 332QH400
4700	77x105	38	26	14.6	20.9	ALS3 -- 472NF400
4700	90x98	36	26	17.1	25.4	ALS3 -- 472QH400
4700	77x146	33	24	18.0	26.0	ALS3 -- 472NP400
6800	77x146	27	20	19.5	26.9	ALS3 -- 682NP400
6800	90x146	24	17	23.2	32.9	ALS3 -- 682QP400
6800	77x220	22	15	29.0	40.7	ALS3 -- 682NT400
10000	90x220	17	12	35.7	49.4	ALS3 -- 103QT400
415 VDC (U_R)						
220	36x52	555	368	2.1	4.4	ALS3 -- 221DA415
330	36x62	372	247	2.7	5.6	ALS3 -- 331DB415
470	36x82	261	173	3.5	7.2	ALS3 -- 471DE415
680	36x105	180	120	4.5	9.0	ALS3 -- 681DF415
1000	51x82	136	94	5.7	10.4	ALS3 -- 102KE415
1500	51x105	90	62	7.6	13.1	ALS3 -- 152KF415
1500	77x75	96	68	8.1	14.7	ALS3 -- 152ND415
2200	66x105	61	42	11.0	18.9	ALS3 -- 222MF415
2200	90x67	71	49	10.5	17.5	ALS3 -- 222QC415
2200	90x75	68	49	11.1	18.9	ALS3 -- 222QD415
3300	77x105	48	36	13.4	21.3	ALS3 -- 332NF415
3300	90x98	45	32	14.6	25.3	ALS3 -- 332QH415
4700	77x146	33	24	17.6	25.9	ALS3 -- 472NP415
6800	90x146	23	17	22.7	32.8	ALS3 -- 682QP415
6800	77x220	21	15	28.5	40.1	ALS3 -- 682NT415
10000	90x220	17	12	35.2	48.7	ALS3 -- 103QT415

Mounting Style 0=plain or 1=stud 
Termination Style A,C,G,J,M or R 

ARTICLE TABLE ALS30 (85°C)

Cap (µF)	Case Size (mm)	ESR (mΩ) at 20°C 100Hz (max)	Impedance (mΩ) at 20°C 10 KHz (max)	Ripple current(A) at 85°C		Type number
				100 Hz	10 KHz	
450 VDC (U_R)						
150	36x52	735	485	1.8	4.1	ALS3 -- 151DA450
220	36x62	502	332	2.4	5.1	ALS3 -- 221DB450
330	36x82	335	221	3.1	6.7	ALS3 -- 331DE450
470	36x105	235	155	4.0	8.4	ALS3 -- 471DF450
680	51x82	175	117	4.9	9.9	ALS3 -- 681KE450
1000	51x105	118	79	6.5	12.6	ALS3 -- 102KF450
1500	77x75	95	65	8.7	14.9	ALS3 -- 152ND450
1500	66x105	81	52	9.5	17.4	ALS3 -- 152MF450
2200	90x67	74	46	9.6	15.4	ALS3 -- 222QC450
2200	90x75	67	47	11.5	19.0	ALS3 -- 222QD450
2200	66x105	67	47	11.1	19.3	ALS3 -- 222MF450
2200	77x105	59	41	12.2	21.1	ALS3 -- 222NF450
3300	90x75	53	33	12.6	17.9	ALS3 -- 332QD450
3300	77x105	40	30	13.8	21.2	ALS3 -- 332NF450
3300	90x98	44	30	15.6	25.5	ALS3 -- 332QH450
3300	77x146	39	27	16.1	25.1	ALS3 -- 332NP450
4700	77x146	36	26	17.1	25.2	ALS3 -- 472NP450
4700	90x146	29	19	21.0	31.8	ALS3 -- 472QP450
6800	77x220	21	14	27.4	38.8	ALS3 -- 682NT450
10000	90x220	18	13	33.4	46.5	ALS3 -- 103QT450
500 VDC (U_R)						
100	36x52	1231	847	1.6	2.9	ALS3 -- 101DA500
150	36x62	823	566	2.0	3.7	ALS3 -- 151DB500
220	36x82	560	386	2.7	4.8	ALS3 -- 221DE500
330	36x82	450	350	3.2	5.7	ALS3 -- 331DE500
330	36x105	374	258	3.5	6.2	ALS3 -- 331DF500
470	51x82	276	194	4.4	7.5	ALS3 -- 471KE500
680	51x105	190	133	5.7	9.6	ALS3 -- 681KF500
1000	77x75	173	109	7.6	12.2	ALS3 -- 102ND500
1000	66x105	137	96	8.1	13.8	ALS3 -- 102MF500
1500	77x105	91	65	10.6	17.0	ALS3 -- 152NF500
1500	90x67	110	87	9.5	14.3	ALS3 -- 152QC500
1500	90x75	119	76	10.1	15.9	ALS3 -- 152QD500
2200	90x98	80	50	13.7	21.1	ALS3 -- 222QH500
2200	77x146	62	44	14.3	21.8	ALS3 -- 222NP500
3300	77x146	54	39	15.3	22.6	ALS3 -- 332NP500
3300	90x146	51	32	19.0	28.3	ALS3 -- 332QP500
4700	77x220	37	24	24.3	33.3	ALS3 -- 472NT500
6800	90x220	27	22	26.5	41.3	ALS3 -- 682QT500

Mounting Style 0=plain or 1=stud 
 Termination Style A,C,G,J,M or R 

OPERATIONAL DATA

Operational Lifetime

Please see separate BHC application notes TD003 for calculating operational life expectancy under customer specific conditions.

RELIABILITY

The failure rate is derived from our periodic test results. The failure rate (λ_p) is therefore only given at test temperature for life tests. An estimation is also given at 40°C. The expected failure rate for this capacitor range is based on our periodic test results for capacitors with structural similarity. Failure rate is frequently quoted in FIT (Failures In Time) where 1 FIT = 1×10^{-9} failures per hour. Failure rates include both catastrophic and parametric failures

T_a	Failure rate per hour
85°C	250 FIT
40°C	12 FIT

MECHANICAL DATA

Mounting position

The capacitor can be mounted in any position so long as the safety vent can operate. It is possible for some electrolyte to be expelled. As this is a conducting liquid, suitable precautions should be instigated by the system designer to avoid secondary short circuits.

The capacitors are designed to be mounted in free air and are not suitable for submersion in liquid.

Vibration

10Hz to 55Hz at 0.75mm or 10g for 3x2hrs duration. Except 220mm long cans 10Hz to 55Hz at 0.35mm or 5g for 3x0.5hrs duration.

Insulating resistance

≥ 100 Mohms at 100V d.c., across insulating sleeve.

Voltage Proof

≥ 2500 V d.c., across insulating sleeve.

Safety vent

A safety vent for over pressure is featured on terminal deck. This is in the form of a rubber plug designed to relieve build up of internal pressure due to over stress or catastrophic failure.