

Drivetrain Prognostics Simulator

DPS

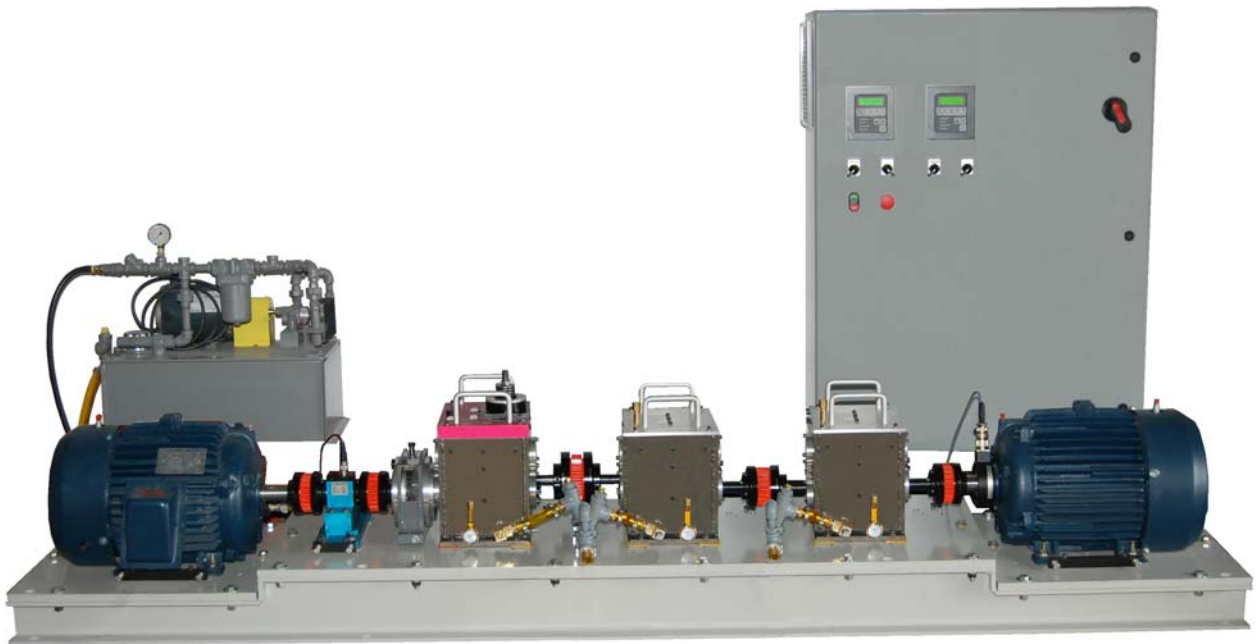

Our Best Tool for Drivetrain Prognostics Research

www.haopute.com
email:info@haopute.com
phone:02884625157
mobile:18982185717

Drivetrain Prognostics Simulator (DPS)

Our Best Tool for Drivetrain Prognostics Research

SpectraQuest's Drivetrain Prognostics Simulator (DPS) has been specifically designed to simulate industrial drivetrains for diagnostics and prognostics research. The DPS drivetrain consists of a two-stage planetary test gearbox and a two-stage parallel shaft test gearbox with rolling or sleeve bearings. These two test gearboxes can be arranged to apply the highest torque to either, a torque which is large enough to induce wear and damage in the gears. The two-stage parallel shaft gearbox can be configured with a gear ratio from 1 to 6. All elements of the DPS have been designed to maximize the number of drivetrain configurations to investigate gearbox dynamics and acoustic behavior, health monitoring, and vibration based diagnostic and prognostics techniques. It is robust enough to handle heavy loads and spacious enough for easy gear placement, setup, and installation of monitoring devices. The two test gearboxes are attached to two parallel shaft load gearboxes and drive.

Gear and Bearing Fault Diagnostics and Prognostics

The effect faults like surface wear, crack tooth, chipped tooth and missing tooth can be demonstrated and induced on either spur gears or helical gears. Rolling element bearing faults like inner race, outer race, and ball damage can also be incorporated. Adjustable clearance to study backlash is possible: increasing the amount of backlash is without major consequence, and reducing backlash can result in binding and/or excessive operating temperatures. Drivetrain misalignment can also be introduced intentionally in the DPS. Any of these faults can be added to the drivetrain one at a time, or simultaneously to study fault interactions. Both torsional and radial loadings can be applied to study damage signature or propagation in gears and/or bearings: the torsional load is applied via a 10 HP variable frequency AC drive with a programmable, user-defined speed profiles; and the radial load is applied to a shaft in the parallel gearbox. With the programmable load drive, load fluctuations can be applied to simulate real life loading conditions.

Features:

- ❖ One 2-stage planetary test gearbox 27:1 ratio.
- ❖ One 2-stage oil-lubricated parallel shaft test gearbox up to 6.25 ratio.
- ❖ Planetary and parallel shaft gearboxes re-locatable to induce damage in either test gearboxes.
- ❖ Torsional and radial variable speed loading.
- ❖ Gears can slide along the parallel shafts to alter system stiffness and make room for additional devices.
- ❖ Parallel shaft gearbox adaptable to spur or helical gears and to rolling element bearings or sleeve bearings.
- ❖ Intentionally damaged or worn gearing can be fitted to study the effects on vibration signature.
- ❖ Alterable backlash by replacing bearing mounting hubs to provide the desired clearance.
- ❖ Modular design makes the introduction of faulted bearing and/or faulted gears an easy task.
- ❖ Load drivetrain consist of one 3-stage and one 2-stage oil-lubricated parallel shaft gearboxes providing up 98:1 ratio.
- ❖ Multiple mounting locations provided for installation of various transducers.
- ❖ Develop diagnosis and prognosis techniques and advanced signal processing methods.

Drivetrain Prognostics Simulator (DPS)

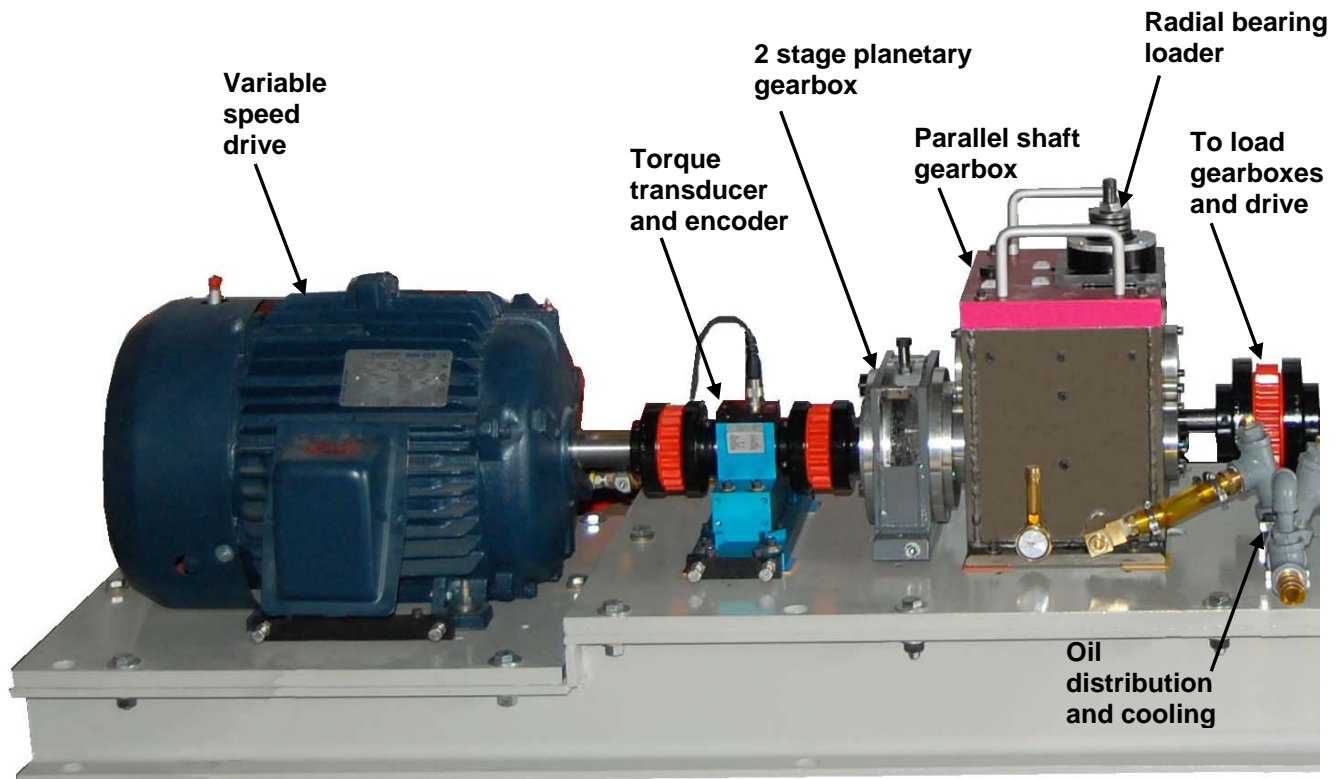

The DPS is Heavy-Duty and Easily Configurable

The DPS design enables changing gearbox and bearing components quickly and easily. The parallel gearbox is adaptable to install either rolling element bearings or oil-impregnated sleeve bearings with either spur or helical gears. The modular design makes the introduction of faulted bearing and/or faulted gears an easy task.

Transducers and DAQ

The drivetrain is designed to accommodate different types of sensors easily. Accelerometers can be installed on the gearboxes and on the bearing housing to measure the vibrations in all three directions. A torque meter enables precise load measurement. The input and output shafts can be fitted with encoder or tachometer to measure the transmission error or for time synchronize averaging. Other transducers can also be installed per customers' request. Data acquisition hardware and software are also available from Spectra Quest and ready to do time domain and frequency domain signal analysis.

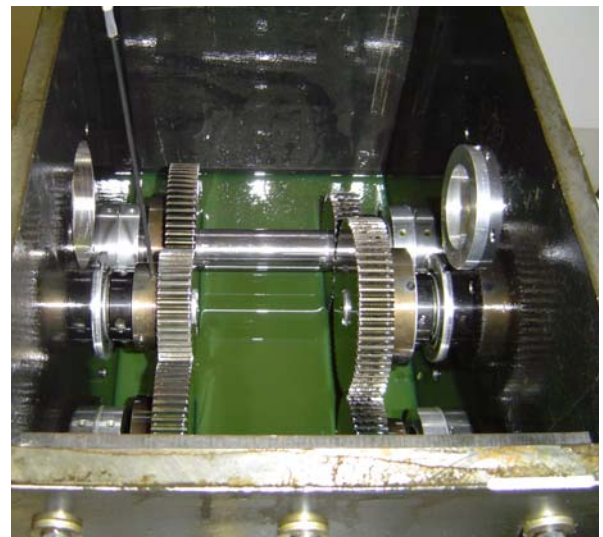

Drivetrain Prognostics Simulator (DPS)

Option Kits

The DPS provides a basic setup for performing drivetrain diagnosis and prognosis experiments. SpectraQuest also offers pre-damaged gears for in-depth study and parallel gearbox conversion kits to helical gear and sleeve bearings.

Option Kits

- ❖ Parallel gearbox bearing fault kit
- ❖ Planetary gearbox bearing fault kit
- ❖ Defective spur gears
- ❖ Helical gears set
- ❖ Defective helical gears
- ❖ Eccentric spur gear
- ❖ Parallel gearbox oil-impregnated sleeve bearing
- ❖ PC motor and load control kit

Specifications

Electrical	
Motor	3 Phase, 20 HP motor
Load	3 Phase, 20 HP motor
Drive	20 HP variable frequency, common bus AC drive system with multi-featured front panel programmable controller
RPM range	0 to 3600 rpm variable speed
Voltage	460 VAC 3 Phase power supply
Mechanical	
Shaft Diameter	1" diameter; Turned, Ground, & Polished (TGP) steel
Test Planetary Gearbox	2-stage, 27:1 gear ratio planetary gear with 4 planet stage1 and 3 planet stage 2
Test Parallel Shaft Gearbox	2-stage, 2.5 maximum ratio per stage (6.25 max), spur or helical gears
Test Parallel Shaft Gearbox Bearing	Deep groove ball bearing or oil-impregnated bronze sleeve bearing
Test Bearing Loader	3000lb capacity with force transducer
Load Gearboxes	98:1 total maximum ratio One 2-stage, 2.5 maximum ratio per stage (6.25 max), spur gears One 3-stage, 2.5 maximum ratio per stage (15.6 max), spur gears Deep groove ball bearing
Torque meter	Up to 100N.m with built-in 360 pulse encoder
Output shaft encoder	360 pulse per turn encoder
Alignment	Jack bolts on gearboxes and motors for horizontal alignment and standard shims for vertical alignment
Oil Distribution	0.9gpm capacity distribution and cooling oil system driven by 1/3HP motor
Fundation	5/8" steel plates on 4"x6" steel beams
Physical	
Weight	Approximately 2200lb (1000kg)
Dimensions	L=112" (285cm), W=22" (56cm), H=22" (56cm) test rig L=30" (76cm), W=16" (41cm), H=26" (66cm) oil distribution D=17" (43cm), W=36" (91cm), H=60" (152cm) motor drive