

1 適用範圍:

本承認書適用於本公司的無鉛、無鹵素之金屬板微電阻含概下列LR系列:

- LR1206 series
- LR2010 series
- LR2512 series
- LR2725 series
- LR2728 series
- LR4527 series

2 料號:

(例)

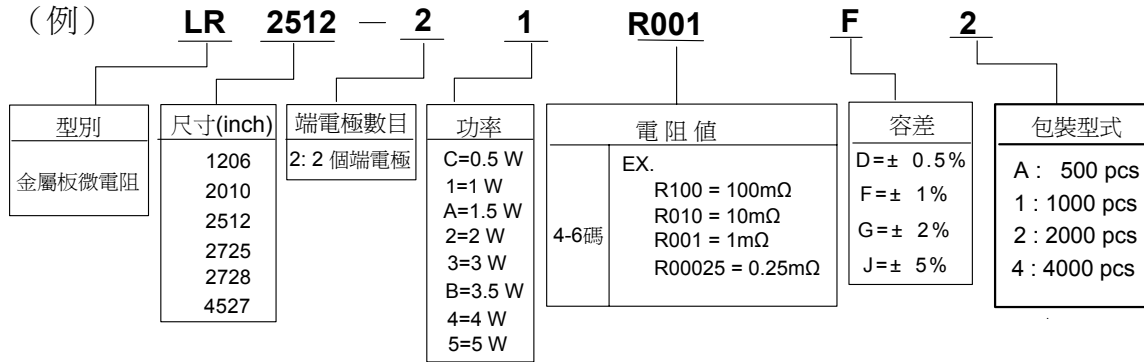

核准

劉和誠

審查

李法也

制定

李法也

註

非發行管制文件
自行注意版本更新

發行管制章 DATA Center.

非經允許，禁止自行影印文件。

序號：**60**

3 規格表:

Type	Number of Terminals	Rated Power at 70°C	Max. Rated Current	Max. Overload Current	T.C.R (ppm / °C)	Resistance Range		Operating Temperature Range
						D(± 0.5%)	F(± 1%)、G(± 2%) J(± 5%)	
LR1206	2	0.5 W	22.36 A	44.72 A	1 ~ 4 mΩ ≤± 50 4.1 ~ 15 mΩ ≤± 25 15.1 ~ 50 mΩ ≤± 15	7 ~ 50 mΩ	1 ~ 50 mΩ	-55°C ~ +170°C
		1 W	31.62 A	63.25 A	1 ~ 4 mΩ ≤± 50 4.1 ~ 15 mΩ ≤± 25 15.1 ~ 50 mΩ ≤± 15	7 ~ 50 mΩ	1 ~ 50 mΩ	
LR2010	2	1 W	31.62 A	63.25 A	1 ~ 3 mΩ ≤± 50 3.1 ~ 6.9 mΩ ≤± 25 7 ~ 100 mΩ ≤± 15	7 ~ 100 mΩ	1 ~ 100 mΩ	
LR2512	2	1 W	44.72 A	100.00 A	0.5 ~ 3 mΩ ≤± 50 3.1 ~ 6.9 mΩ ≤± 25 7 ~ 100 mΩ ≤± 15	7 ~ 100 mΩ	0.5 ~ 100 mΩ	
		1.5 W	54.77 A	122.48 A	0.5 ~ 3 mΩ ≤± 50 3.1 ~ 6.9 mΩ ≤± 25 7 ~ 100 mΩ ≤± 15	7 ~ 75 mΩ	0.5 ~ 75 mΩ	
		2 W	63.25 A	141.42 A	0.5 ~ 3 mΩ ≤± 50 3.1 ~ 6.9 mΩ ≤± 25 7 ~ 75 mΩ ≤± 15	7 ~ 10 mΩ	0.5 ~ 10 mΩ	
		3 W	77.46 A	134.16 A	0.5 ~ 2.5 mΩ ≤± 50 2.6 ~ 10 mΩ ≤± 25	--	0.25 ~ 3 mΩ	
LR2725	2	4 W	126.49 A	252.95 A	≤± 50	--	0.25 ~ 3 mΩ	
LR2728	2	3 W	27.39 A	47.43 A	4 ~ 7 mΩ ≤± 25 7.1 ~ 100 mΩ ≤± 15	4 ~ 100 mΩ		
		3.5 W	29.58 A	51.23 A	4 ~ 7 mΩ ≤± 25 7.1 ~ 50 mΩ ≤± 15	4 ~ 50 mΩ		
		4 W	31.62 A	63.25 A	4 ~ 7 mΩ ≤± 25 7.1 ~ 50 mΩ ≤± 15	4 ~ 50 mΩ		
LR4527	2	3 W	77.5A	134A	≤± 50	7 ~ 120 mΩ	0.5 ~ 120 mΩ	
		5 W	100A	173A				

備註

非發行管制文件
自行注意版本更新

發行管制章 DATA Center.

非經允許，禁止自行影印文件。

序號：60

3.1 功率衰減曲線:

使用溫度範圍：- 55 ~ +170 °C

當電阻工作在溫度超過70°C時，額定功率必須減額,減額曲線依據下圖：

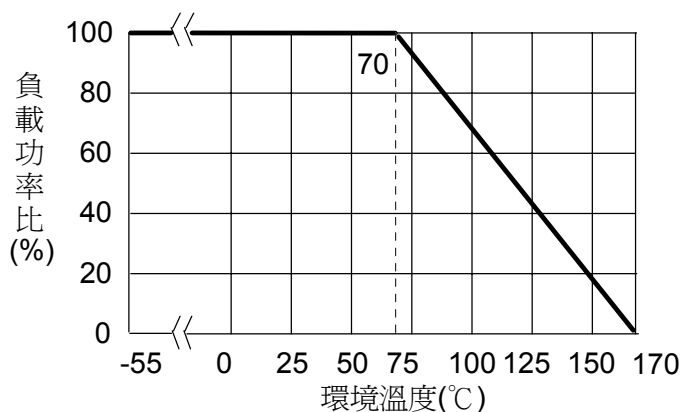

3.2 額定電流:

額定電流:對於額定功率之直流或交流(商用週率有效值RMS(Root Mean Square,均方根值)電流。

可用下列公式求得，但求得之值若超過規格表內之最高電流時，則以最高額定電流為其額定電流。

$$I = \sqrt{P/R}$$

I = 額定電流(A)
P=額定功率(W)
R=阻值(Ω)

4 尺寸:

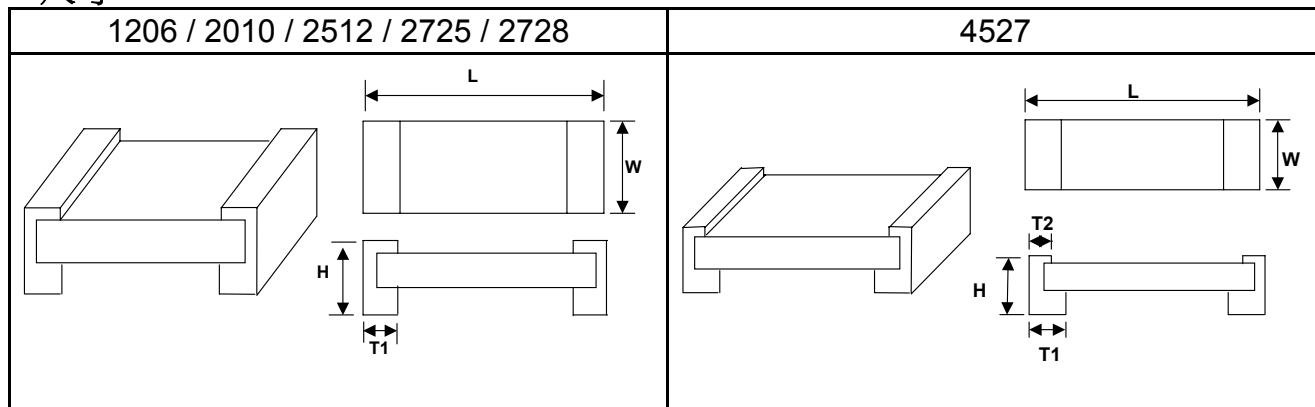

TYPE	Power Rating (W)	Resistance Range (mΩ)	Dimensions (mm)				
			L	W	H	T1	T2
LR1206	0.5 1	1~50	3.200± 0.254	1.600± 0.254	0.645± 0.254	0.508± 0.254	
LR2010	1	1.0~3	5.080± 0.254	2.540± 0.254	0.787± 0.254	1.295± 0.254	
		3.1~100			0.645± 0.254	0.787± 0.254	
LR2512	1 1.5	0.5~4	6.248± 0.254	3.302± 0.254	0.787± 0.254	1.880± 0.254	
		4.1~75			0.645± 0.254	1.118± 0.254	
		75.1~100			0.645± 0.254	0.868± 0.254	
	2	0.5~4			0.787± 0.254	1.880± 0.254	
		4.1~75			0.645± 0.254	1.118± 0.254	
	3	0.5			1.880± 0.254		
		0.6~2.9 4.1~10			0.787± 0.254	1.118± 0.254	
		3~4			1.676± 0.254		
LR2725	4	0.25、0.5	6.807± 0.254	6.452± 0.254	0.991± 0.254	2.159± 0.254	
		1			1.092± 0.254		
		1.5			0.991± 0.254		
		2			0.889± 0.254	1.803± 0.254	
		2.5			1.651± 0.254		
		3			1.295± 0.254		
LR2728	3 3.5 4	4~100	6.706± 0.254	7.188± 0.254	0.991± 0.254	1.143± 0.254	
LR4527	3 5	0.5	11.430± 0.254	6.850± 0.254	1.500± 0.254	3.215±0.254	3.215±0.254
		0.6~5.0				1.815±0.254	0.965±0.254
		5.1~120					

備註

非發行管制文件
自行注意版本更新

發行管制章 DATA Center.

非經允許，禁止自行影印文件。

序號：60

5 信賴性試驗項目:

5.1 電性功能試驗(Electrical Performance Test)

Item 項目	Conditions 條件	Specifications 規格																												
Temperature Coefficient of Resistance 溫度係數	$TCR \text{ (ppm/}^\circ\text{C)} = \frac{(R2 - R1)}{R1 (T2 - T1)} \times 10^6$ R1:室溫下量測之阻值(Ω) R2:+150°C下量測之阻值(Ω) T1:室溫之溫度(°C) T2:+150°C之溫度(°C)。 依據 JIS-C5201-1 4.8	參考段落3.規格表																												
Short Time Overload 短時間過負荷	施加過負荷5秒，靜置30分鐘以上再量測阻值變化率。 (過負荷條件參照下表)	$\leq \pm 0.5\%$ $\leq \pm 2.0\%$ (4527-3W & 4527-5W) 外觀無損傷，無短路或燒毀現象。																												
	<table border="1"> <thead> <tr> <th>型別</th> <th>過負荷</th> </tr> </thead> <tbody> <tr> <td>LR1206-0.5W</td> <td>4 times of rated power</td> </tr> <tr> <td>LR1206-1W</td> <td>4 times of rated power</td> </tr> <tr> <td>LR2010-1W</td> <td>4 times of rated power</td> </tr> <tr> <td>LR2512-1W</td> <td>5 times of rated power</td> </tr> <tr> <td>LR2512-1.5W</td> <td>5 times of rated power</td> </tr> <tr> <td>LR2512-2W</td> <td>5 times of rated power</td> </tr> <tr> <td>LR2512-3W</td> <td>3 times of rated power</td> </tr> <tr> <td>LR2725-4W</td> <td>4 times of rated power</td> </tr> <tr> <td>LR2728-3W</td> <td>3 times of rated power</td> </tr> <tr> <td>LR2728-3.5W</td> <td>3 times of rated power</td> </tr> <tr> <td>LR2728-4W</td> <td>4 times of rated power</td> </tr> <tr> <td>LR4527-3W</td> <td>3 times of rated power</td> </tr> <tr> <td>LR4527-5W</td> <td>3 times of rated power</td> </tr> </tbody> </table>	型別	過負荷	LR1206-0.5W	4 times of rated power	LR1206-1W	4 times of rated power	LR2010-1W	4 times of rated power	LR2512-1W	5 times of rated power	LR2512-1.5W	5 times of rated power	LR2512-2W	5 times of rated power	LR2512-3W	3 times of rated power	LR2725-4W	4 times of rated power	LR2728-3W	3 times of rated power	LR2728-3.5W	3 times of rated power	LR2728-4W	4 times of rated power	LR4527-3W	3 times of rated power	LR4527-5W	3 times of rated power	
	型別	過負荷																												
	LR1206-0.5W	4 times of rated power																												
	LR1206-1W	4 times of rated power																												
	LR2010-1W	4 times of rated power																												
	LR2512-1W	5 times of rated power																												
	LR2512-1.5W	5 times of rated power																												
	LR2512-2W	5 times of rated power																												
	LR2512-3W	3 times of rated power																												
	LR2725-4W	4 times of rated power																												
	LR2728-3W	3 times of rated power																												
	LR2728-3.5W	3 times of rated power																												
LR2728-4W	4 times of rated power																													
LR4527-3W	3 times of rated power																													
LR4527-5W	3 times of rated power																													
(最高過負荷電流值請參考 3.規格表) 依據 JIS-C5201-1 4.13																														
Insulation Resistance 絕緣電阻試驗	將金屬板微電阻置於治具上，在正負極施加100 VDC一分鐘後，測量電極與保護層及電極與基板(底材)間之絕緣電阻值。 依據 JIS-C5201-1 4.6	$\geq 10^9 \Omega$																												
Dielectric Withstand Voltage	將金屬板微電阻置於治具上，在正、負極施加500 VAC。 限制突波電流：50mA(max.) 依據 JIS-C5201-1 4.7	無短路或燒毀現象。																												

備註

非發行管制文件
自行注意版本更新

發行管制章 DATA Center.

非經允許，禁止自行影印文件。

序號：60

5.2 機械性功能試驗(Mechanical Performance Test)

Item 項目	Conditions 條件	Specifications 規格
Solderability 焊錫性	將金屬板微電阻浸漬於245± 5°C之爐中3± 1秒後取出置於顯微鏡下觀察焊錫面積。 依據 JIS-C5201-1 4.17	導體吃錫面積應大於95%。
Resistance to Solvent 耐溶劑性試驗	將金屬板微電阻浸漬於20~25°C異丙醇溶劑中60± 5秒後，取出靜置48小時以上，再量測阻值變化率。 依據 JIS-C5201-1 4.29	≤± 0.5% 外觀無損傷
Resistance to soldering heat 抗焊錫熱	將金屬板微電阻浸漬於260± 5°C之錫爐中10± 1秒，取出靜置60分鐘以上，再量測阻值變化率。 依據 JIS-C5201-1 4.18	≤± 0.5% 外觀無損傷
Vibration 耐振性試驗	震動頻率:10 Hz ~ 55 Hz ~ 10 Hz/分 振幅:1.5 mm 測試時間:12小時(X.Y.Z 3個方向各4小時) 依據 JIS-C5201-1 4.22	≤± 0.5% 外觀無損傷

5.3 環境試驗(Environmental Test)

Item 項目	Conditions 條件	Specifications 規格								
High Temperature Exposure 高溫放置	將金屬板微電阻置於170± 5°C之烤箱中1000小時，取出靜置1小時以上再量測阻值變化率。 依據 JIS-C5201-1 4.23.2	≤± 1.0% 外觀無損傷。								
Low Temperature Exposure 低溫放置	將金屬板微電阻放置-55± 2°C恆溫箱中1000小時，取出後靜置60分鐘以上後再量測阻值變化率。 依據 JIS-C5201-1 4.23.4	≤± 0.5% 外觀無損傷。								
Temperature cycling (Rapid Temperature Change) 溫度循環	將金屬板微電阻置入冷熱循環機中，溫度為-55°C/15分鐘，+150°C/15分鐘，共計循環1000次後取出，靜置60分鐘以上再量測阻值變化率。 <table border="1" style="margin-left: 20px;"> <thead> <tr> <th colspan="2">測試條件</th> </tr> </thead> <tbody> <tr> <td>最低溫度</td> <td>-55 +0/-10°C</td> </tr> <tr> <td>最高溫度</td> <td>150 +10/-0°C</td> </tr> <tr> <td>溫度保留時間</td> <td>15 分鐘</td> </tr> </tbody> </table> 依據 JIS-C5201-1 4.19	測試條件		最低溫度	-55 +0/-10°C	最高溫度	150 +10/-0°C	溫度保留時間	15 分鐘	≤± 0.5% 外觀無損傷。
測試條件										
最低溫度	-55 +0/-10°C									
最高溫度	150 +10/-0°C									
溫度保留時間	15 分鐘									
Moisture Resistance 耐濕試驗	將金屬板微電阻置於恆溫恆濕循環機中，並依步驟1至步驟7(參考圖一)施加10濕熱循環，取出靜置24小時以上再量測阻值變化率。 依據 MIL-STD 202 Method 106	≤± 0.5% 外觀無損傷。								
Moisture Life 高溫高濕	將金屬板微電阻置於85°C± 5°C/ 85 ± 5%RH之恆濕恆溫循環機中施加額定電流，90分鐘ON，30分鐘OFF，共1,000小時取出靜置60分鐘以上再量測阻值變化率。 依據 JIS-C5201-1 4.24	≤± 0.5% 外觀無損傷。								
Load Life 負荷壽命	將金屬板微電阻置於70± 2°C之烤箱中施加額定電流，90分鐘ON，30分鐘OFF，共1,000小時取出靜置60分鐘以上再量測阻值變化率。 依據 JIS-C5201-1 4.25	≤± 1.0% ≤± 2.0% (4527-3W & 4527-5W) 外觀無損傷。								

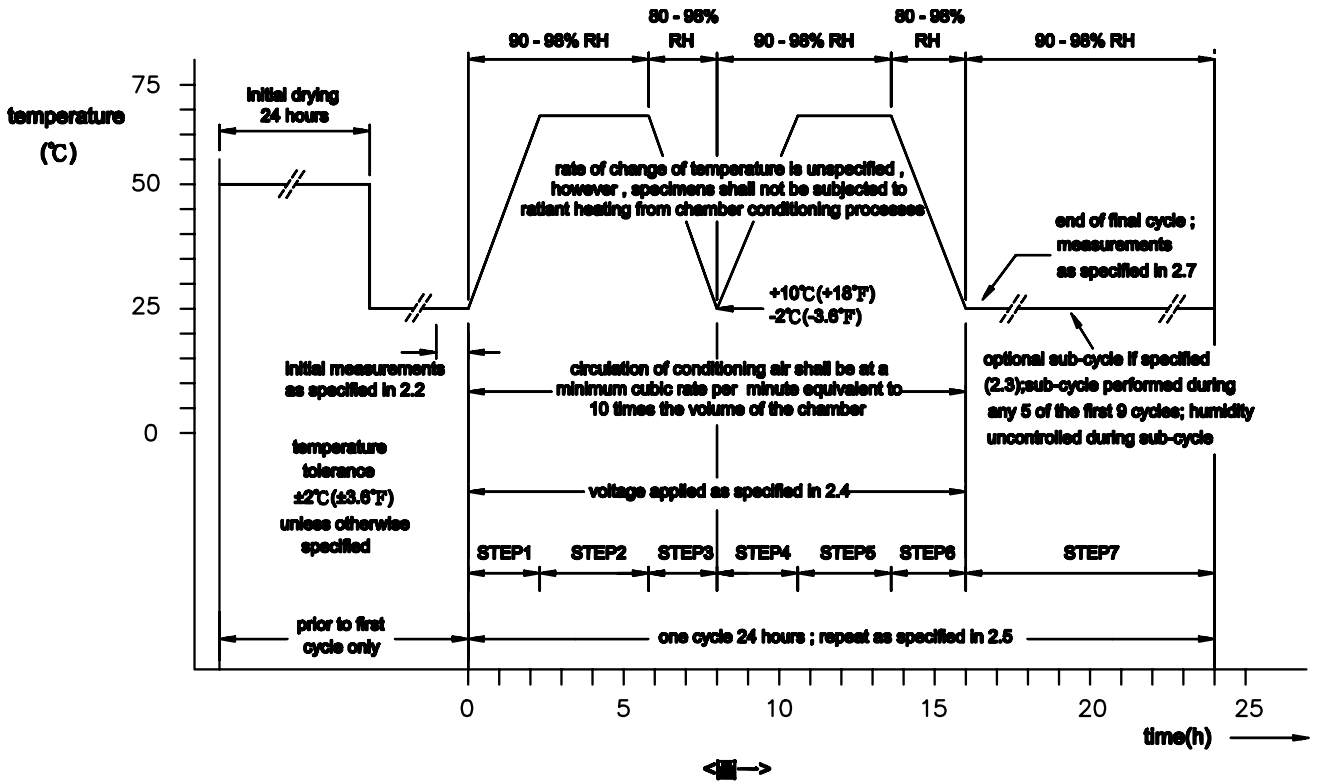

6 建議焊錫條件:

6.1 IR Reflow Soldering Profile

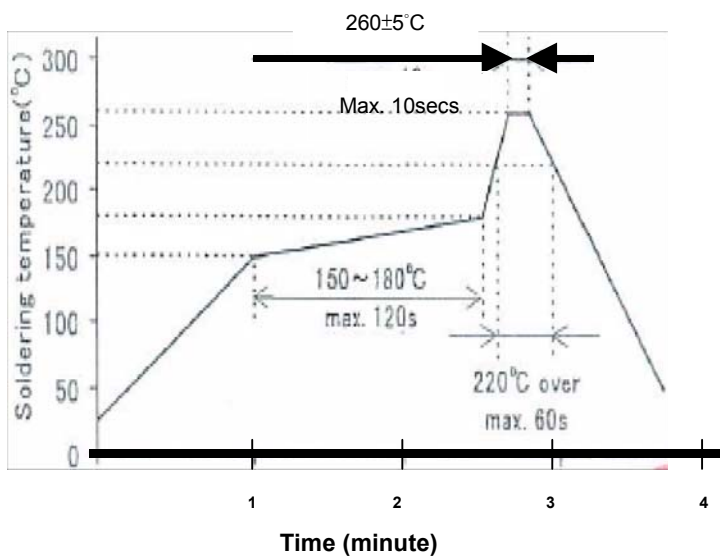

備註

非發行管制文件
自行注意版本更新

發行管制章 DATA Center.

非經允許，禁止自行影印文件。

序號：60

6.2 Wave Soldering Profile

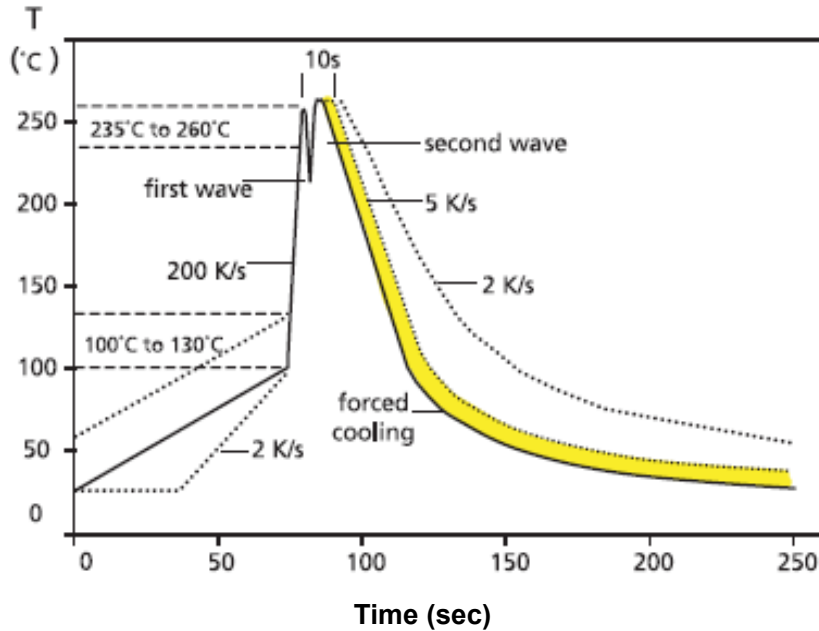

7 建議 Land Pattern :

Unit : mm

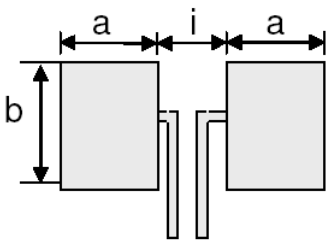

TYPE	Maximum Power Rating (Watts)	Land Pattern Dimensions			
		Resistance Range (mΩ)	a	b	i
LR1206	0.5 & 1.0	1.0~50.0	1.60	2.18	1.00
LR2010	1.0	1.0~3.0	2.89	2.92	1.22
		3.1~100.0	2.29	2.92	2.41
LR2512	1.0 & 1.5	0.5~4.0	3.05	3.68	1.27
		4.1~100.0	2.11	3.68	3.18
LR2512	2.0	0.5~4.0	3.05	3.68	1.27
		4.1~75.0	2.11	3.68	3.18
LR2512	3.0	0.50	3.05	3.68	1.27
		0.6~2.9 & 4.1~10.0	2.19	3.68	3.00
		3.0 ~ 4.0	2.79	3.68	1.80
LR2725	4.0	0.25~3.0	3.18	6.86	1.32
LR2728	3.0、3.5 & 4.0	4.0~100.0	2.75	7.82	3.51
LR4527	3.0 & 5.0	0.5~5.0	4.80	8.74	5.51
		5.1~120	3.40	8.74	8.31

Unit :mm

備註

非發行管制文件
自行注意版本更新

發行管制章 DATA Center.

非經允許，禁止自行影印文件。

序號：60

8 字碼表示法(所有產品蓋印皆為4字碼):

8.1 LR1206 :

《EX》 Marking → R010 = 10 mΩ (for all LR06 products)



8.2 LR2010

《EX》 Marking → R002 = 2 mΩ (below or equal than 3 mΩ)



《EX》 Marking → R005 = 5 mΩ (greater than 3 mΩ)



8.3 LR2512

《EX》 Marking → 0m50 = 0.5 mΩ (below than 1 mΩ)



《EX》 Marking → R003 = 3 mΩ (below or equal than 4 mΩ)



《EX》 Marking → R005 = 5 mΩ (greater than 4 mΩ)



《EX》 Marking → 5m25 = 5.25 mΩ (greater than 4 mΩ)

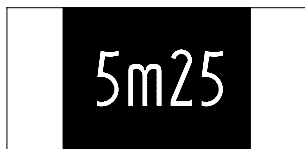

《EX》 Marking → 25m5 = 25.5 mΩ (greater than 4 mΩ)



8.4 LR2725

《EX》 Marking → 0m25 = 0.25 mΩ (for 0.25 mΩ only)

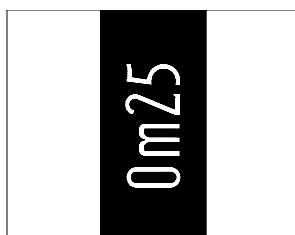

《EX》 Marking → 2m50 = 2.5 mΩ (for 2.5 mΩ only)

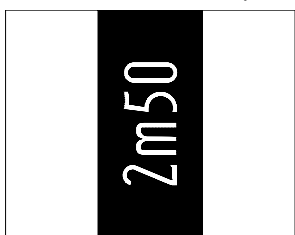

《EX》 Marking → R003 = 3 mΩ (for 1 mΩ, 2 mΩ and 3 mΩ only)

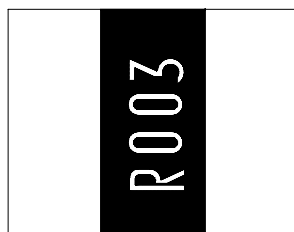

8.5 LR2728

《EX》 Marking→R005=5 mΩ (for all LR28 products)

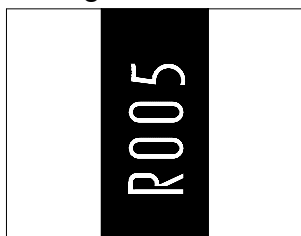

8.6 LR4527

《EX》 Marking→0m50=0.5 mΩ (for 0.50 mΩ only)

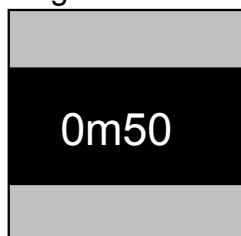

《EX》 Marking→R010=10 mΩ



《EX》 Marking→15m5=15.5 mΩ



9 包裝:

9.1 紙帶尺寸(Tape Dimensions):

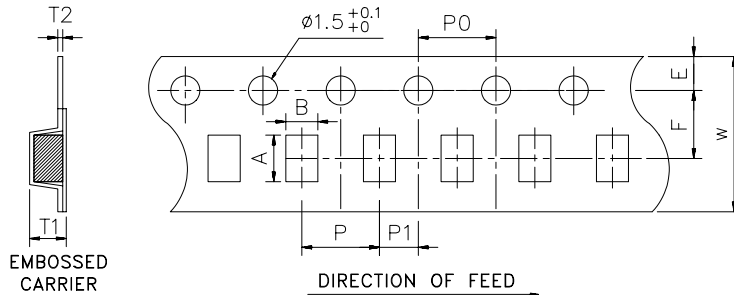

DIM TYPE	A	B	W	E	F	T1	T2	P	P0	10x P0	P1
LR1206	3.48± 0.10	1.83± 0.10	8.0± 0.15	1.75± 0.10	3.5± 0.10	0.90± 0.10	0.20± 0.05	4.0± 0.10	4.0± 0.10	40.0± 0.20	2.0± 0.10
LR2010	5.45± 0.10	2.90± 0.10	12.0± 0.15	1.75± 0.10	5.5± 0.10	1.10± 0.10	0.23± 0.05	4.0± 0.10	4.0± 0.10	40.0± 0.20	2.0± 0.10
LR2512	6.74± 0.10	3.90± 0.10	12.0± 0.15	1.75± 0.10	5.5± 0.10	1.08± 0.10	0.24± 0.05	8.0± 0.10	4.0± 0.10	40.0± 0.20	2.0± 0.10
LR2725	7.15± 0.10	6.75± 0.10	12.0± 0.15	1.75± 0.10	5.5± 0.10	1.70± 0.10	0.25± 0.05	8.0± 0.10	4.0± 0.10	40.0± 0.20	2.0± 0.10
LR2728	7.15± 0.10	7.70± 0.10	12.0± 0.15	1.75± 0.10	5.5± 0.10	1.20± 0.10	0.25± 0.05	12.0± 0.10	4.0± 0.10	40.0± 0.20	2.0± 0.10
LR4527	11.80± 0.10	7.20± 0.10	24.0± 0.15	1.75± 0.10	11.5± 0.10	1.70± 0.10	0.30± 0.10	12.0± 0.10	4.0± 0.10	40.0± 0.20	2.0± 0.10

9.2 包裝數量:

Type	Tape Width	Packaging Quantity (pcs/reel)		
		Emboss Plastic Type		
		4 mm Pitch	8 mm Pitch	12 mm Pitch
LR1206	8 mm	4000 pcs		
LR2010	12 mm	2000 pcs		
LR2512	12 mm		2000 pcs	
LR2725	12 mm		1000 pcs	
LR2728	12 mm			1000 pcs
LR4527	24 mm			500 pcs

9.3 塑膠圓盤尺寸(Reel Dimensions):

Unit : mm

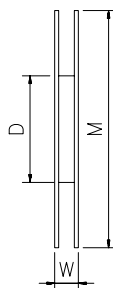
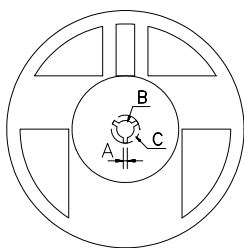

Reel Type/ Tape	W	M	A	B	C	D
7" reel for 8 mm tape	12.0 ± 0.5	178 ± 1.0	2.0 ± 0.5	13.2 ± 0.5	17.7 ± 0.5	60.0 ± 0.5
7" reel for 12 mm tape	16.2 ± 0.5		2.5 ± 0.5	13.5 ± 0.5		60.0 ± 0.5
7" reel for 24 mm tape	24.4 +2/-0		2.0 ± 0.5	13.2 ± 0.5		60.0 ± 0.5

10 附件

10.1 文件修訂記錄表 (QA-QR-027)

備註	非發行管制文件 自行注意版本更新	發行管制章 DATA Center.
	非經允許，禁止自行影印文件。	