

## DATA SHEET

### TRANSIENT VOLTAGE SUPPRESSORS – HF-L SERIES

#### FEATURES

- ✧ Axial lead terminals
- ✧ High current transient suppressor
- ✧ Excellent clamping capability.
- ✧ Glass passivated junction.
- ✧ Bi-directional.
- ✧ Low slope resistance.
- ✧ Repetition Rate (duty cycle):0.01%.
- ✧ Hazardous substances free.
- ✧ RoHS compliant
- ✧ High Temperature soldering: 260°C/10 seconds at terminals.
- ✧ Epoxy encapsulated.
- ✧ Meets MSL level 1, per J-STD-020



#### MAXIMUM RATINGS AND THERMAL CHARACTERISTICS

Rating	Symbol	Value		Units
Current Rating	$I_{PP}$	HFA-L	3	KAmps
		HFB-L	6	
		HFC-L	10	
		HFD-L	16	
Operating junction and Storage Temperature Range.	$T_J, T_{STG}$	-55 to +150		°C

**DIMENSIONS**

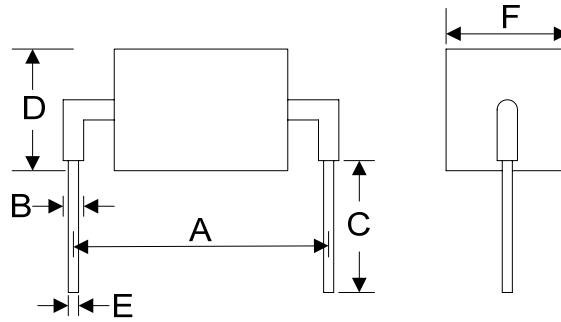

HFA / HFB / HFC(012-190)-L Series			HFC(012/015/200/240)-L / HFD-L Series		
Symbol	Inches	Millimeters	Symbol	Inches	Millimeters
A	0.951±0.047	24.15±1.20	A	0.951±0.047	24.15±1.20
B	0.055min	1.40min	B	0.055min	1.40min
C	0.236±0.047	6.0±1.20	C	0.236±0.047	6.0±1.20
D	0.512max	13.0max	D	0.630max	16.0max
E	0.050±0.004	1.28±0.10	E	0.050±0.004	1.28±0.10
F	0.512max	13.0max	F	0.630max	16.0max

HFB-430L			HFC-430L		
Symbol	Inches	Millimeters	Symbol	Inches	Millimeters
A	1.063±0.047	27.00±1.20	A	1.024±0.047	26.00±1.20
B	0.055min	1.40min	B	0.055min	1.40min
C	0.079min	2.00min	C	0.079min	2.00min
D	0.512max	13.0max	D	0.630max	16.0max
E	0.050±0.004	1.28±0.10	E	0.050±0.004	1.28±0.10
F	0.512max	13.0max	F	0.630max	16.0max

**ELECTRICAL CHARACTERISTICS**

Part Number	Reverse Stand-Off Voltage		Breakdown Voltage	Test Current	Current Rating	Maximum Energy	Maximum Clamping Voltage	Reverse Leakage
	V <sub>AC</sub> (V)	V <sub>DC</sub> (V)	V <sub>BR</sub> (V) MIN.@I <sub>T</sub>	I <sub>T</sub> (mA)	Rated I <sub>PP</sub> measured with 8/20μs pulse	10/1000μs	V <sub>C</sub> (V) @I <sub>PP</sub>	I <sub>R</sub> (μA) @V <sub>DC</sub>
HFA-012L	8.5	12.8	14	1	3KA	500	80	20
HFA-015L	11	15	17	1	3KA	650	85	20
HFA-020L	14	20	22	1	3KA	800	90	20
HFA-025L	17	25	28	1	3KA	950	95	20
HFA-030L	21	30	33	1	3KA	1200	100	20
HFA-042L	30	42	47	1	3KA	1700	105	20
HFA-058L	40	58	64	1	3KA	2450	110	20
HFA-066L	45	66	70	1	3KA	2600	120	20
HFA-076L	54	76	85	1	3KA	2800	140	20
HFA-100L	72	100	110	1	3KA	4250	165	20
HFA-133L	100	133	147	1	3KA	5300	220	20
HFA-170L	130	170	180	1	3KA	7000	260	20
HFA-190L	145	190	200	1	3KA	8400	290	20
HFA-200L	150	200	222	1	3KA	8600	330	20
HFA-240L	180	240	250	1	3KA	9100	340	20
HFA-275L	210	275	300	1	3KA	9500	435	20
HFA-300L	230	300	330	1	3KA	12750	470	20
HFA-380L	275	380	401	1	3KA	15000	520	20
HFA-430L	310	430	440	1	3KA	18000	625	20
HFA-460L	330	460	500	1	3KA	18500	770	20
HFA-500L	385	500	558	1	3KA	19500	868	20
HFB-012L	8.5	12.8	14	1	6KA	1000	80	20
HFB-015L	11	15	17	1	6KA	1300	85	20
HFB-020L	14	20	22	1	6KA	1600	90	20
HFB-025L	17	25	28	1	6KA	1900	95	20
HFB-030L	21	30	33	1	6KA	2400	100	20
HFB-042L	30	42	47	1	6KA	3400	105	20
HFB-058L	40	58	64	1	6KA	4900	110	20
HFB-066L	45	66	70	1	6KA	5200	120	20
HFB-076L	54	76	85	1	6KA	5600	140	20
HFB-100L	72	100	110	1	6KA	8500	165	20
HFB-133L	100	133	147	1	6KA	10600	220	20
HFB-170L	130	170	180	1	6KA	14000	260	20
HFB-190L	145	190	200	1	6KA	16800	290	20
HFB-200L	150	200	222	1	6KA	17200	330	20

Notes: 1. T<sub>A</sub>=25°C unless otherwise specified

2. Using 8/20μs wave shape pulses as defined in IEC61000-4-5

**ELECTRICAL CHARACTERISTICS**

Part Number	Reverse Stand-Off Voltage		Breakdown Voltage	Test Current	Current Rating	Maximum Energy	Maximum Clamping Voltage	Reverse Leakage
	V <sub>AC</sub> (V)	V <sub>DC</sub> (V)	V <sub>BR</sub> (V) MIN.@I <sub>T</sub>	I <sub>T</sub> (mA)	Rated I <sub>PP</sub> measured with 8/20μs pulse	10/1000μs	V <sub>C</sub> (V) @I <sub>PP</sub>	I <sub>R</sub> (μA) @V <sub>DC</sub>
HFB-240L	180	240	250	1	6KA	18000	340	20
HFB-275L	210	275	300	1	6KA	19000	435	20
HFB-300L	230	300	330	1	6KA	25500	470	20
HFB-380L	275	380	401	1	6KA	30000	520	20
HFB-430L	310	430	440	1	6KA	30000	625	20
HFC-012L	8.5	12.8	14	1	10KA	1665	80	20
HFC-015L	11	15	17	1	10KA	2164.5	85	20
HFC-020L	14	20	22	1	10KA	2664	90	20
HFC-025L	17	25	28	1	10KA	3163.5	95	20
HFC-030L	21	30	33	1	10KA	3996	100	20
HFC-042L	30	42	47	1	10KA	5661	105	20
HFC-058L	40	58	64	1	10KA	8158.5	110	20
HFC-066L	45	66	70	1	10KA	8658	120	20
HFC-076L	54	76	85	1	10KA	9324	140	20
HFC-100L	72	100	110	1	10KA	14152.5	165	20
HFC-133L	100	133	147	1	10KA	17649	220	20
HFC-170L	130	170	180	1	10KA	23310	260	20
HFC-190L	145	190	200	1	10KA	27972	290	20
HFC-200L	150	200	222	1	10KA	28638	330	20
HFC-240L	169	240	250	1	10KA	29970	400	20
HFC-430L	310	430	440	1	10KA	49950	625	20
HFD-012L	8.5	12.8	14	1	16KA	2665	80	20
HFD-015L	11	15	17	1	16KA	3464.5	85	20
HFD-020L	14	20	22	1	16KA	4264	90	20
HFD-025L	17	25	28	1	16KA	5063.5	95	20
HFD-030L	21	30	33	1	16KA	6396	100	20
HFD-042L	30	42	47	1	16KA	9061	105	20
HFD-058L	40	58	64	1	16KA	13058.5	110	20
HFD-066L	45	66	70	1	16KA	13858	120	20
HFD-076L	54	76	85	1	16KA	14924	140	20
HFD-100L	72	100	110	1	16KA	22652.5	165	20
HFD-133L	100	133	147	1	16KA	28249	220	20
HFD-170L	130	170	180	1	16KA	37310	260	20
HFD-190L	145	190	200	1	16KA	44772	290	20
HFD-200L	150	200	222	1	16KA	45838	330	20

Notes: 1. T<sub>A</sub>=25°C unless otherwise specified

2. Using 8/20μs wave shape pulses as defined in IEC61000-4-5

**RATINGS AND CHARACTERISTIC CURVES** (TA=25°C unless otherwise noted)

**Figure 1. Power Derating Curve**

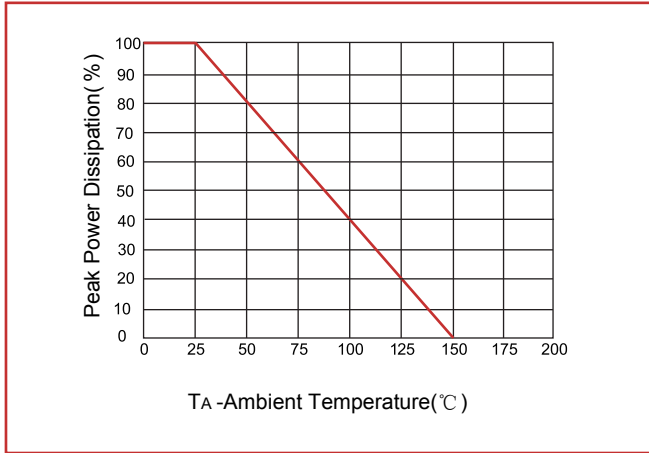

**Figure 2. Pulse Waveforms**

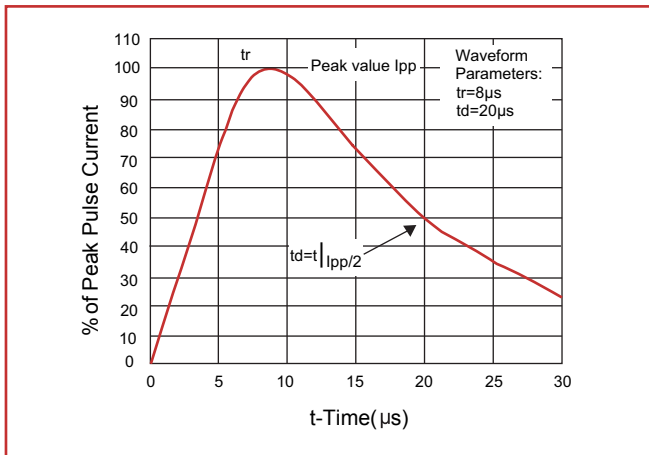

**Figure 3. Flow / wave Soldering**

