

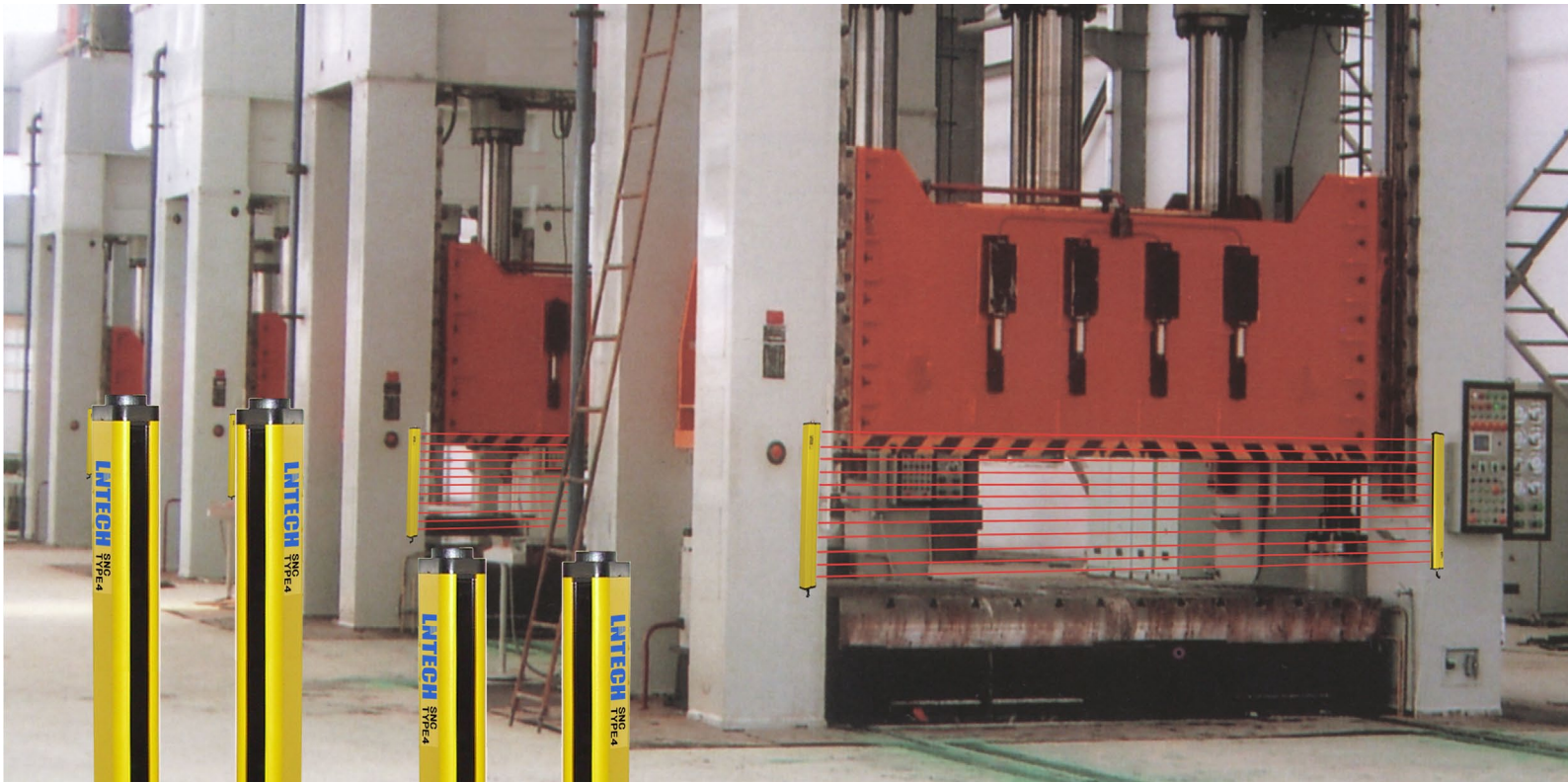

SND (E) 系列光电保护装置 SND(E) Series Safety Light Curtain

光电保护装置专业制造商 光电安全技术专家

Safety light curtain specialized manufacturer, optic-electronic safety technology expert



符合国际安全标准4级

Conforms To The International
Safety Standards Type 4



山东莱恩光电科技有限公司

SHANDONG LAIEN OPTIC-ELECTRONIC TECHNOLOGY CO., LTD.

我们致力于营造一个安全的作业环境！
We work hard to help you make a safer workplace.



山东莱恩光电科技有限公司是一家高起点、高标准的国家高新技术企业，是锻压机械标准化委员会成员单位。主要从事光电安全产品的研发、制造和销售，为机械加工、机械制造企业提供安全保护产品和技术解决方案。

专业的技术、先进的设备、成熟的工艺、完善的质量保证体系和丰富的安全保护从业经验，是我们为您提供优质产品和服务的保证。

主导产品光电保护装置，又称光电保护器、安全光幕、安全光栅，主要与具有潜在危险的机械设备配套，如冲压机械、剪切设备、金属切削设备、自动化装配线、自动化焊接线、机械传送搬运设备、危险区域，保护作业人员的人身安全。

Shandong Laien optic-electronic technology Co., Ltd. is the high beginning, high standard technology corporation, is a member unit of the forging and stamping machinery standardization commission. It is mainly engaged in research, development, manufacture and sale of the photoelectric product. It is professional manufacturer, and mainly provides the safekeeping products and the safety work solution for the machine-finishing, manufacture factories.

Leading product is photoelectric protector, also named protector, safety light curtain, and safety grating. It is equipped for mechanical equipment with potential hazard, such as press machinery, shearing equipment, metal cutting equipment, automated assembly line, automated solder line, machinery transmission equipment, dangerous region, to protect operator's personal safety.



应用领域 Application Area

主要用于机械制造、机械加工行业，与具有潜在危险的机械设备配套，保护操作人员的人身安全。

冲压机械，剪切机械，折弯机械，自动化装配线，自动化焊接线，机械传送、搬运设备，立体车库，橡塑机械，制模机，压滤机，木工机械，自动化涂装设备，切纸机，自动仓储设备，其它危险区域。

Mainly be used in the machine-finishing profession, equipped for mechanical equipment with potential hazard to protect operator's personal safety. Presswork machinery, Shearing equipment, Metal cutting equipment, Automated assembly line, Automated solder line, Machinery transmission equipment, Three-dimensional garage, Rubber, Plastic processing machinery, Machinery carrying equipment, and other dangerous regions.

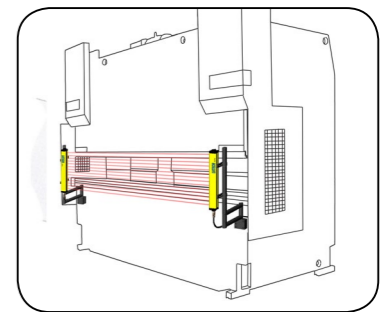
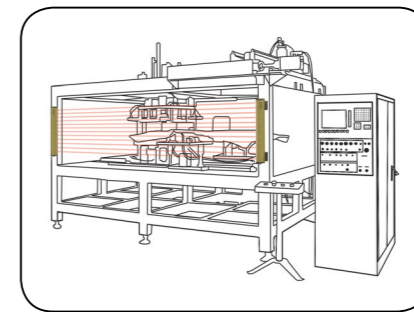
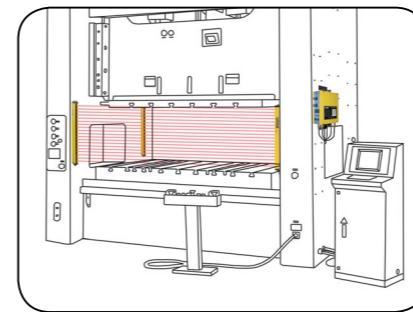
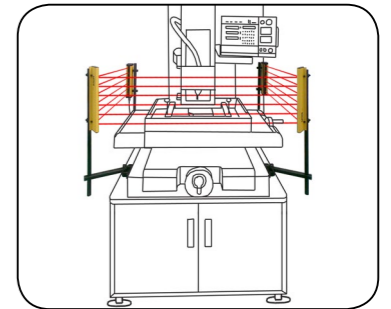
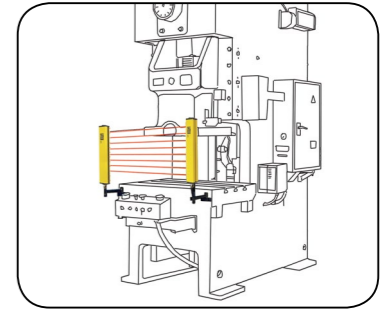

光轴间距与检测精度的关系

The relation between light axis pitch and detection capability

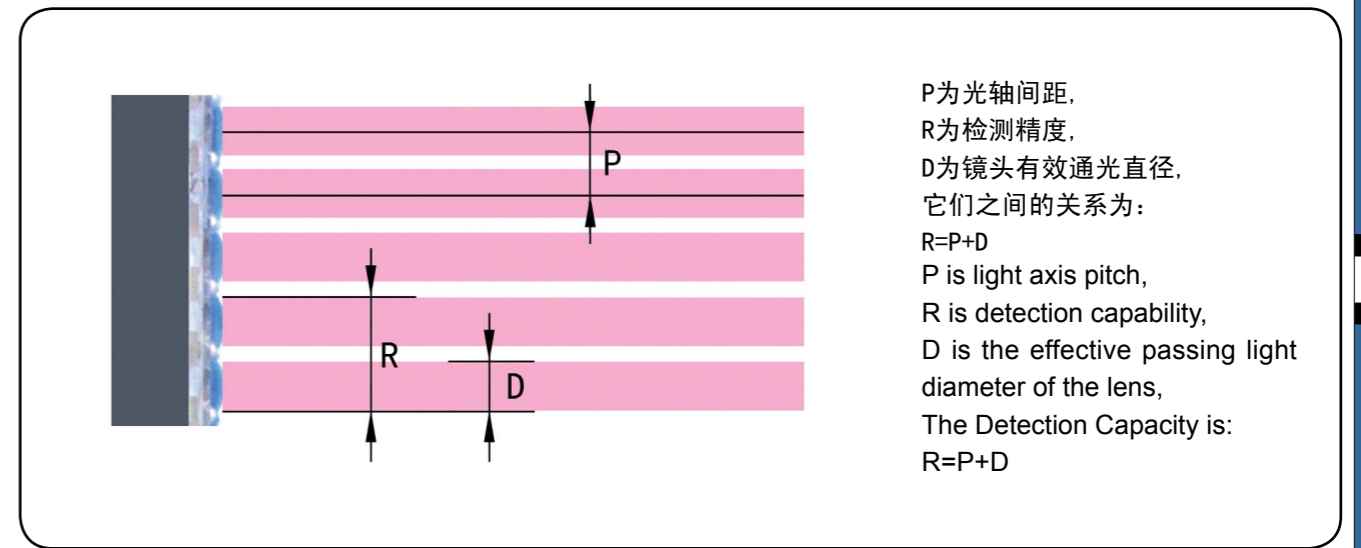

规格说明 Specification express

光电保护装置的规格由三部分组成，以“-”分开，第一部分表示光幕装置，如果没有副光幕，括号和括号内的内容省略；第二部分表示控制器，如果是PNP输出，则没有控制器；第三部分表示附加信息，所列条目可组合罗列，T为特殊要求，需另外注明。

例如：

SND (E) 2620-PNP-SH

SND (E) 系列，26光束，光轴间距20mm，PNP输出，使用双旋臂分体钢管支架，加装防护罩；

如果光束数、光轴间距为三位数，则前两位数字用字母代替，“10”-A，“11”-B，“12”-C，“13”-D，“14”-E，依此类推。

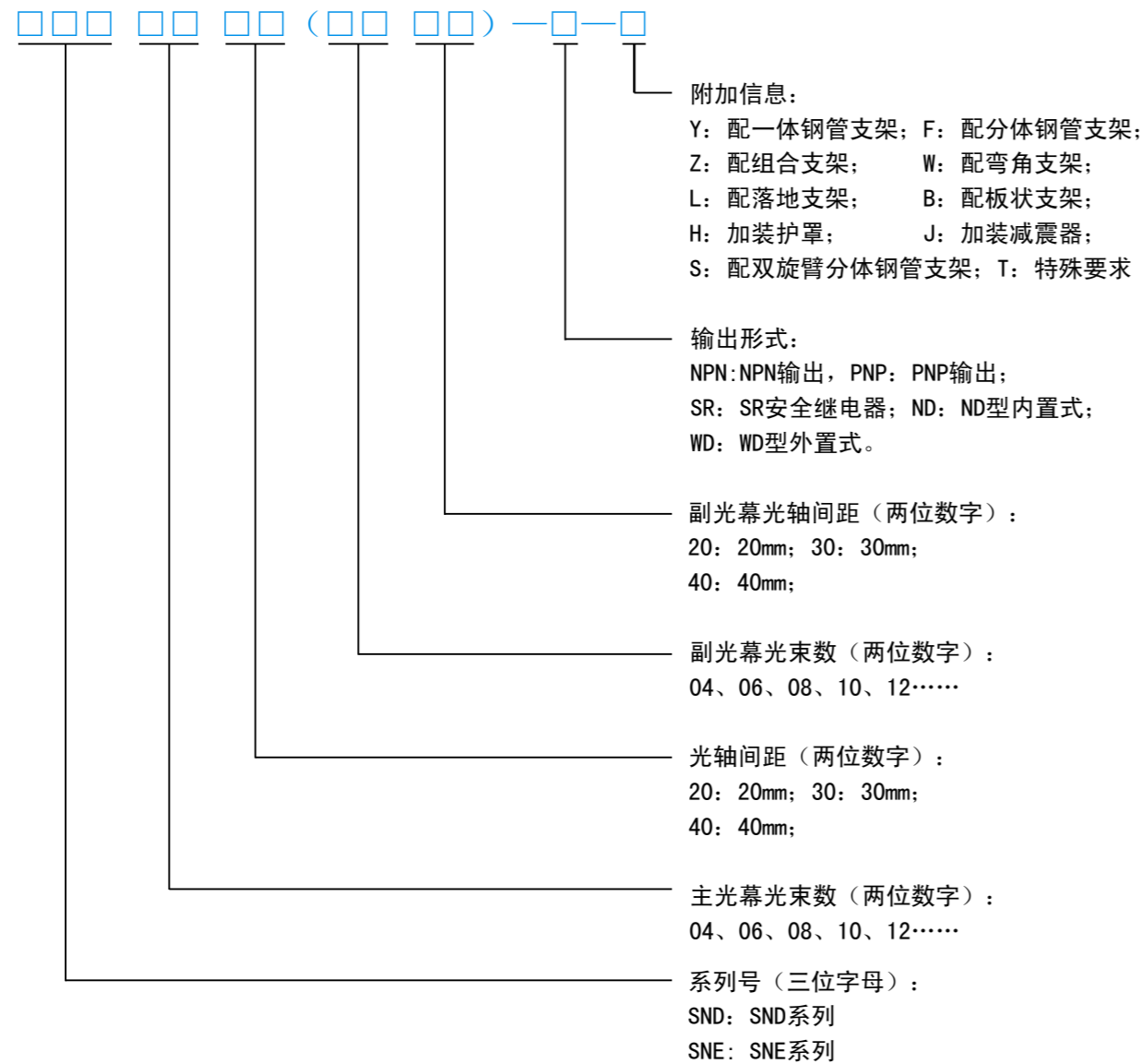

The specifications of the protector contains three parts spaced by “-”; the first part denotes the light curtain, if no subsidiary light curtain, omit the brackets and the contents of the brackets; the second part denotes controller, if it is PNP output, there is no controller; the third part denotes additive information, entries listed can combine and list, T is the special request, and need specify aside.

For example:

SND(E)2620-PNP-SH

The SND(E) series, 26 light beams, light axis pitch is 20mm, PNP output, mounting double rotatable arms steel pipe brackets, addition guard shields;

Note:

If the beam number, the light axis pitch are three digits, then the first two digits are replaced by a letter: A-10,B-11,C-12,D-13,E-14 and so on.

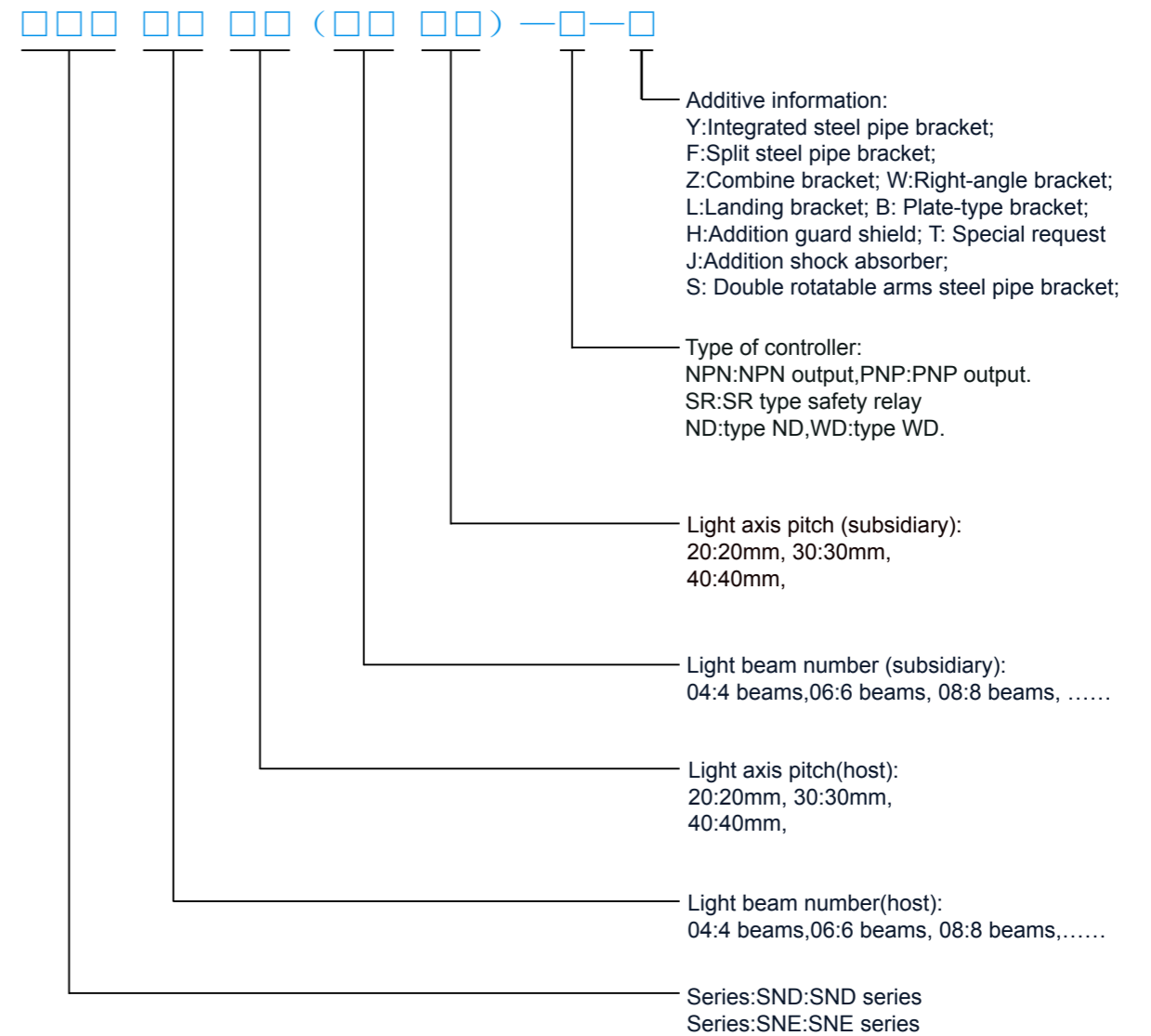

产品特点 Charateristics

- 规格品种多, 适用范围广。
常规产品保护高度有 100mm 到 1560mm 多种规格。
- 自检功能完善
电路设计采用冗余和自检设计, 确保当光电保护装置自身出现故障时, 不向所控制的电路发送错误信号。
- 再启动连锁功能
遮断光幕, 压力机滑块立即停止, 当光幕再次通光时, 压力机滑块不能自动恢复运行, 必须按动复位按钮后, 冲床、压力机滑块才能再次运行。
- 抗干扰能力强
系统对电磁信号、频闪灯光、焊接弧光及周围光源等具有良好的抗干扰能力。
- 使用寿命长, 可靠性高。
- 抗振性能好。
- 具备 EDM 功能
- 具有辅助对光功能
- 具有接线指示功能
- 具有故障指示功能

- Specifications Varieties, Application Wide**
The protective height of conventional products is from 100mm to 1560mm;
- Peffect self-checking function**
Ensure that the photoelectric protector don't send the mistaken signal to the controlled electrical equipment when it has faults.
- The Self-locking Function**
If preset the self-locking function, the press slide stops moving after interception of light curtain. But the press can not be restart, when the light curtain is recovered to passing through state. It shall be restart by pressing the reset button.
- Immunity**
For the electromagnetism signal,the intense lamplight,the welding and surrounding light source has better immunity.
- Durable life and High reliability**
- Good Anti-vibration**
- EDM Function**
- Auxiliary Focusing Function**
- Wiring Indicating Function**
- Troubles Indicating Function**

技术参数 Technical parameters

工作电源	DC24V±15%	Operating power	DC24V±15%
发射光源	红外, 940nm	Emission light	Infrared light, 940nm
输出类型	PNP*2 (NPN*2 可选)	Output type	PNP*2 (or NPN*2)
功耗	<15W	Power consumption	<15W
适用温度	-10℃~55℃	Ambient temperature	-10℃~55℃
环境湿度	20℃, RH≤85%	Humidity	20℃, RH≤85%
响应时间	5~20ms (随光路数目的增加而增加)	Response time	5~20ms
绝缘电阻	>100MΩ	Insulating resistance	>100MΩ
介电强度	AC1500V, 60s. 无闪络或击穿现象	Dielectric strength	AC1500V, one minute, no sparkle appears
抗光干扰	10000Lux (入射角≥5°)	Resistance to light interference	10000Lux (angle of incidence ≥5°)
检测精度	D/E 系列光轴间距+10mm/20mm SND 系列: 30mm, 40mm, 50mm SNE 系列: 40mm, 50mm, 60mm	Detection Capability	D/E series Light axis pitch+10mm/20mm SND series: 30mm, 40mm, 50mm SNE series: 40mm, 50mm, 60mm
外壳材料	发光器、受光器外壳: 铝合金;	Shell material	Sensor: Aluminium alloy;
密封	传感器: IP65;	Sealing	Sensor: IP65
保护长度	SND 系列: 0~8000mm; SNE 系列: 0~20000mm	Protective range	SND series: 0~8000mm SNE series: 0~20000mm
保护高度	H=(光束数-1)×光轴间距	Protective height	H=(beams-1)×light axis pitch

SND(E)系列光电保护装置 SND(E) series safety light curtain

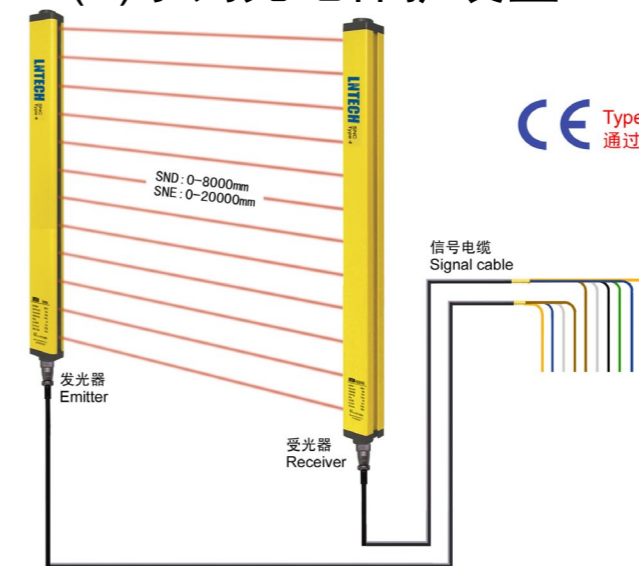

- ◆ 特点:
安装调试方便, 配线简单, 结构小巧, 外形美观
- ◆ 光幕形式: 对射式
- ◆ 检测精度: D 系列 30mm, 40mm, 50mm,
E 系列 40mm, 50mm, 60mm
- ◆ 保护长度: SND: 0~8000mm; SNE: 0~20000mm
- ◆ 保护高度: 100~1560mm 为常规产品
标准配置: 发光器/1支, 受光器/1支, 信号电缆/3m、8m 各1根, 安装附件/1套;
型号表述: SND (E) □□□□-□-□
如果需要两面保护, 需另配1套反射镜,
型号表述: SND (E) □□□□-□-2□
如果需要三面保护, 需另配2套反射镜,
型号表述: SND (E) □□□□-□-3□
如果需要级联光幕, 需另配1套副光幕,
◆ 型号表述: SND (E) □□□□ (□□□□) -□-□
◆ 安装方式: 参见第9、10页
特别提示: 可选配控制器
如果需要使用DC24V作为工作电源, 订货时需特别说明: 如果信号电缆、控制电缆需加长, 订货时需特别说明

- ◆ Characteristic:
The installation and adjustment are convenient,the wiring is simple, structure compact, the contour is artistic.
- ◆ Light curtain form: Direct transmission type
- ◆ Detection capability: D series: 30mm, 40mm, 50mm
E series: 40mm, 50mm, 60mm
- ◆ Protective range: SND: 0~8000mm ; SNE: 0~20000mm
- ◆ Protective height: 100~1560mm is the conventional product.
Standard configuration:
Emitter/1, Receiver/1, Signal cable 3m/1 root, 8m/1 root , Installation fittings/1 set;
Model indication: SND(E) □□□□-□-□
If it is 2 sides protection, it also needs 1 set mirror,
Model indication: SND(E) □□□□-□-2□
If it is 3 sides protection, it also needs 2 set mirror,
Model indication: SND(E) □□□□-□-3□
If it is cascade light curtain, it also needs 1 set subsidiary light curtain,
◆ Model indication: SND(E) □□□□ (□□□□) -□-□
◆ Installation way: See also 9th, 10th page.
Prompts specially:
If the power source need to be DC24V, the special explanation should be made on order.
If the length of signal and controller cables need to lengthen, the special explanation should be made on order.



NPN/PNP输出型光幕接线图

NPN/PNP output wiring

- ◆ 有些设备可以识别光幕传感器输出的NPN/PNP接点信号,并且工作电源为DC24V或DC12V,在客户有明确要求的情况下,可提供NPN和PNP输出方式,此时应保证后续的控制电路符合安全标准的要求。
- ◆ NPN/PNP输出接点技术参数:
工作电流: <200mA
响应时间: 5~20ms
负载电流: <100mA
- ◆ There are some equipments can monitor NPN/PNP contact signal output by light curtain sensor ,and working power source is DC24 or DC12V;In the case of a clear requirements of customers, it can provide NPN/PNP output way,at this time ,we should guarantee the follow-up control circuit correspond the requirements of safety standards.
- ◆ Technical parameters of NPN/PNP output contacts
Working current:<200mA Response time:5~20ms
Load current:<100mA

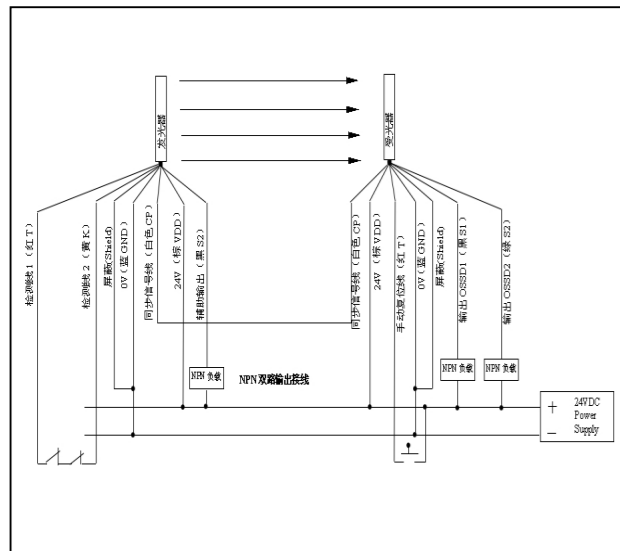

NPN输出接线图
The wiring diagram of NPN output

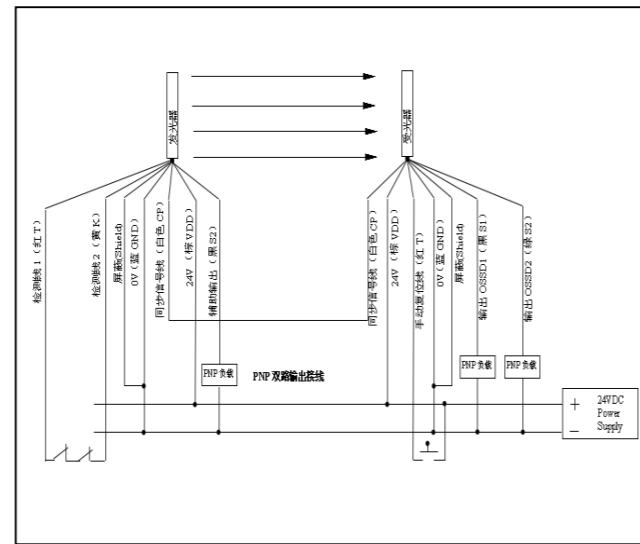

PNP输出接线图
The wiring diagram of PNP output

级联光幕 Cascade light curtain

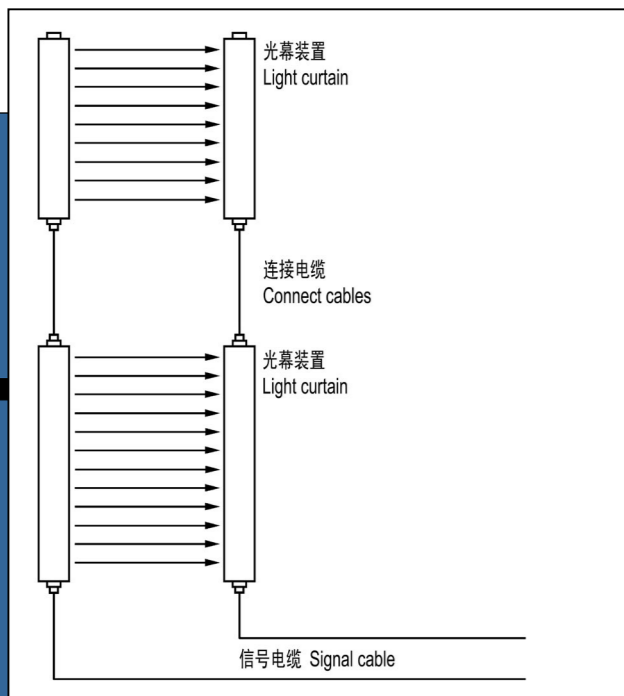

- ◆ 有些设备需要在不同平面上安装光电保护装置,可将两套光幕装置的发光器与发光器串联起来,受光器与受光器串联起来,最多可以串联3级。
- ◆ Some equipments need to install the protector in different plane,in this case,two sets of light curtain may be connected in series,3 series at most .

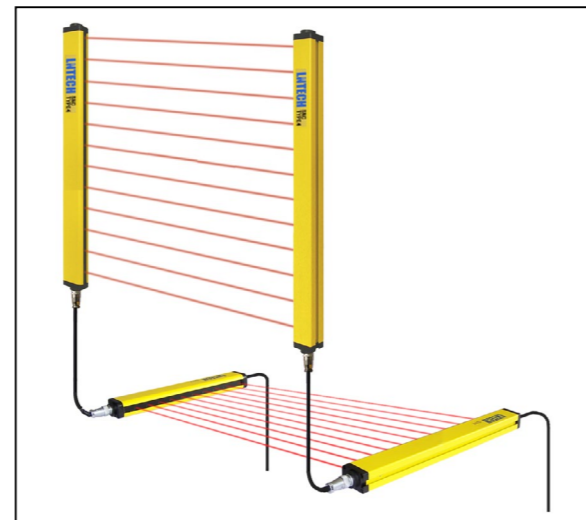

SND (E) 型光电保护装置的安装方式

SND(E) series safety light curtain installation ways

主要安装方式 Main Installations

The ways of installation showed in this page,integrated steel pipe brackets/split steel pipe brackets and combined brackets are three kind of main installation ways which almost can satisfy the protector's mounting. Combined bracket is composed of two parts,their combination angle can be changed by changing the installation position. Other methods showed in next page are used to solve some special problems,they are provided for special request. The double rotary arms steel pipe bracket is to solve the question that the light curtain is supported unreliable when the steel pipe surpassed 1000mm. The shield is to solve the question that the sensor is collided to damage frequently. The right-angle bracket is simple and practical for fixing,it is fixed through two right-angle brackets with the sensor on mechanical device column,its shortcoming is that the angle is not easy to adjust,it is suitable for the fitting surface which is smooth situation. The landing bracket is used in the area protection generally,its merit is may reduce the vibration to be smallest. The combined bracket adds shock absorbers,installs 4 $\Phi 20 \times 20$ shock aborbers between two right-angle brackets,it can reduce the vibration effectively, mainly uses in where vibration is large.

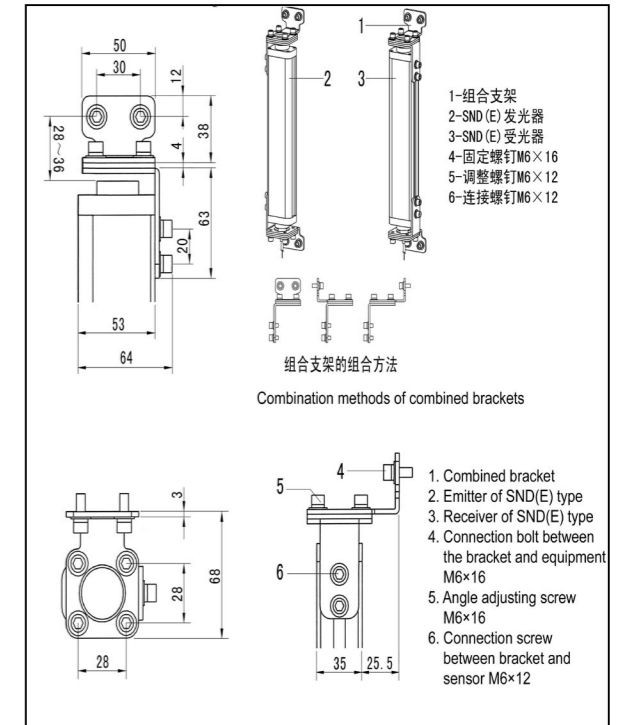

组合支架安装方式
Installation of combined brackets

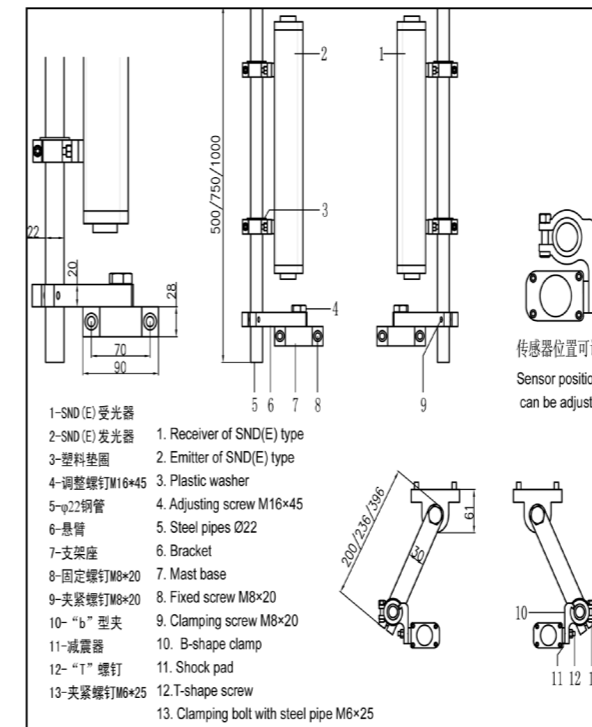

分体钢管支架安装方式
Installation of split steel pipe brackets

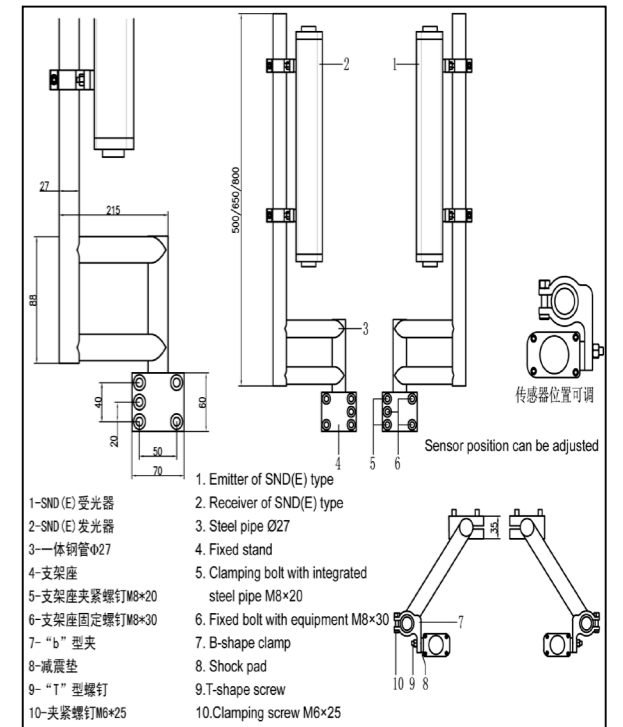

一体钢管支架安装方式
Installation of integrated steel pipe brackets

其它安装方式 Other Installations

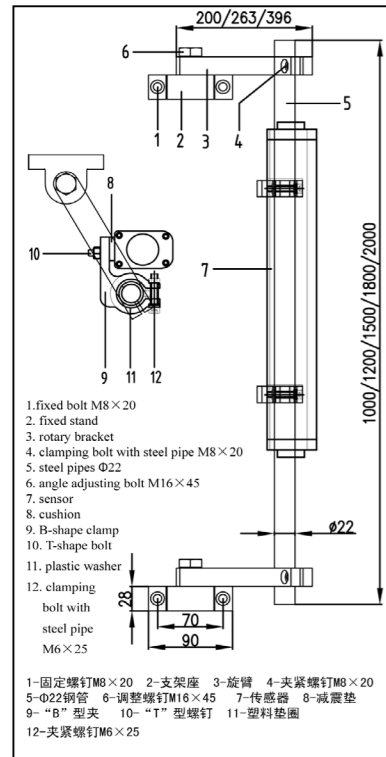

双旋臂钢管支架安装方式
Double rotary arms steel pipe bracket

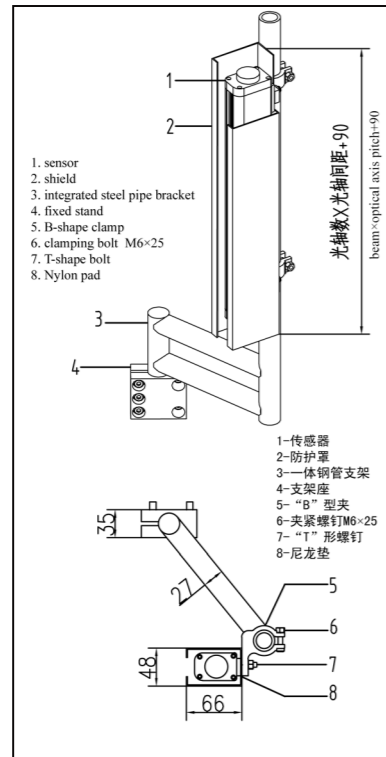

加装防护罩
Mounting the sensor with shield

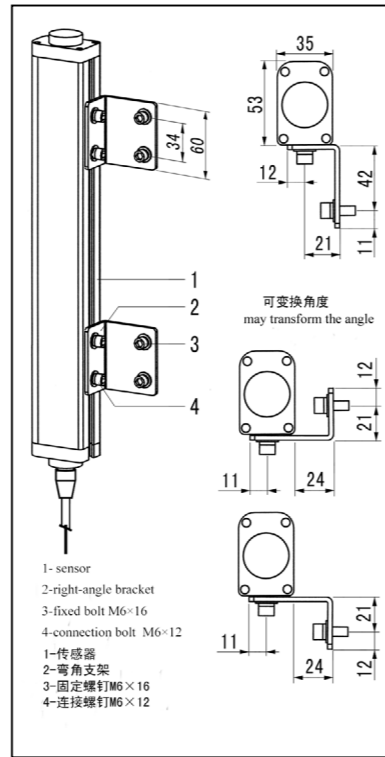

弯角支架安装方式
Right-angle brackets

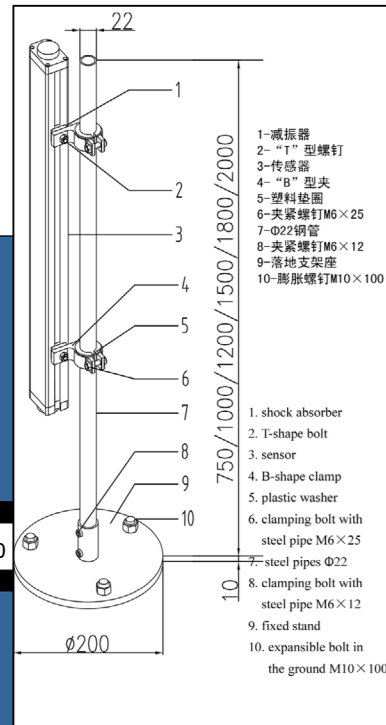

落地支架安装方式
Landing steel pipe bracket

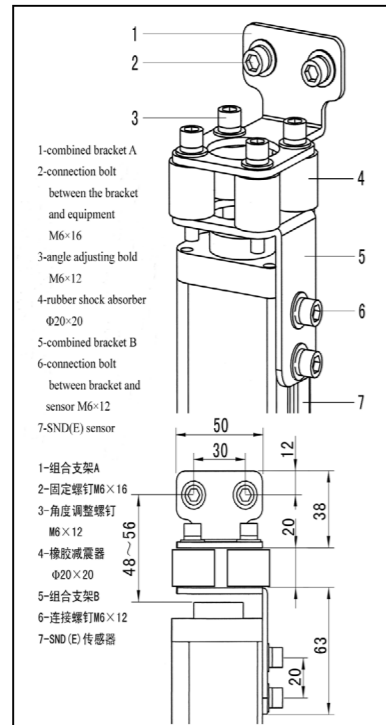

组合支架加装减震器
Combined brackets,fitting rubber shock absorbers

- ◆ 一体钢管支架、分体钢管支架、组合支架为三种主要的安装方式，基本可以满足光电保护装置安装的需要
- ◆ 组合支架是由两部分组合而成，可通过组合的角度，改变安装的角度
- ◆ 其他安装方式是为了解决一些特殊的问题，用户特别要求时提供
- ◆ 双旋臂钢管支架是为了解决钢管超过1000mm时，支架不牢固的问题
- ◆ 防护罩是为了解决传感器经常被碰撞而损坏的问题
- ◆ 弯角支架安装方式简单实用，通过两个直角弯板将传感器固定在机械设备的立柱上，其缺点是角度不易调整，适用于安装面较平整的场合
- ◆ 落地支架一般用于区域保护，其优点是可将振动减到最小
- ◆ 组合支架加装减震器，是在组合支架的上下部分中间，加装4只Φ20×20减震器，可有效减小振动，主要用于振动较大的场合

SR型安全继电器 SR type safety relay



- ◆ Installation position: Inside installation, it can use DIN rail to be installed in electrical cabinet of mechanical equipment ◆ Box material: PPO
- ◆ External dimension: height×broad×deep=96×22.5×116mm
- ◆ Control cable port: 4P plug terminals ◆ Signal cable port: 4P plug terminals
- ◆ Control light curtain number: 1 set ◆ Input signal form: Double road NPN/PNP signal
- ◆ Output signal form: Safety relay contact signals, 2N/O 3N outputs
- ◆ Output contact capacity: AC-15, 5A/250V; DC-13, 6A/24V, contact fuse protection is 4A T or 6A F ◆ Operating power: DC24V±15% ◆ Power consumption: <15W
- ◆ Self-checking function: For the signal processing electric circuit and the output contact carry on monitoring, if the exceptional instance is detected, the output state locks in "fault" immediately, until trouble remove.
- ◆ Self-locking function: The self-locking function is set, the interface S33/S34 can be set as single reset or manually reset (need to reserve)
- ◆ Working indication: Power supply/the channel 1 (CH1)/the channel 2 (CH2) work indicator LED.

◆安放位置：内置式，可利用DIN轨道安装在机械设备的电气柜内 ◆材料：PPO ◆外形：高×宽×深=96×22.5×116mm ◆控制电缆接口：4P插接端子 ◆信号电缆接口：4P插接端子 ◆控制光幕数量：1套 ◆输入信号形式：双路NPN、PNP信号 ◆输出形式：安全继电器，2常开1常闭或3常开 ◆输出触点容量：AC-15, 5A/250V; DC-13, 6A/24V, 触点熔丝保护4A慢或6A快 ◆工作电源：DC24V±15% ◆功耗：<15W ◆自检功能：对信号处理电路、继电器触点进行监控，如发现异常，将输出状态锁定在“故障状态”，直到故障排除 ◆自锁功能：设置了自锁功能，接口S33、S34可设置为单次复位或手动复位（需预定） ◆工作状态指示：电源、通道1（CH1）、通道2（CH2）工作指示灯

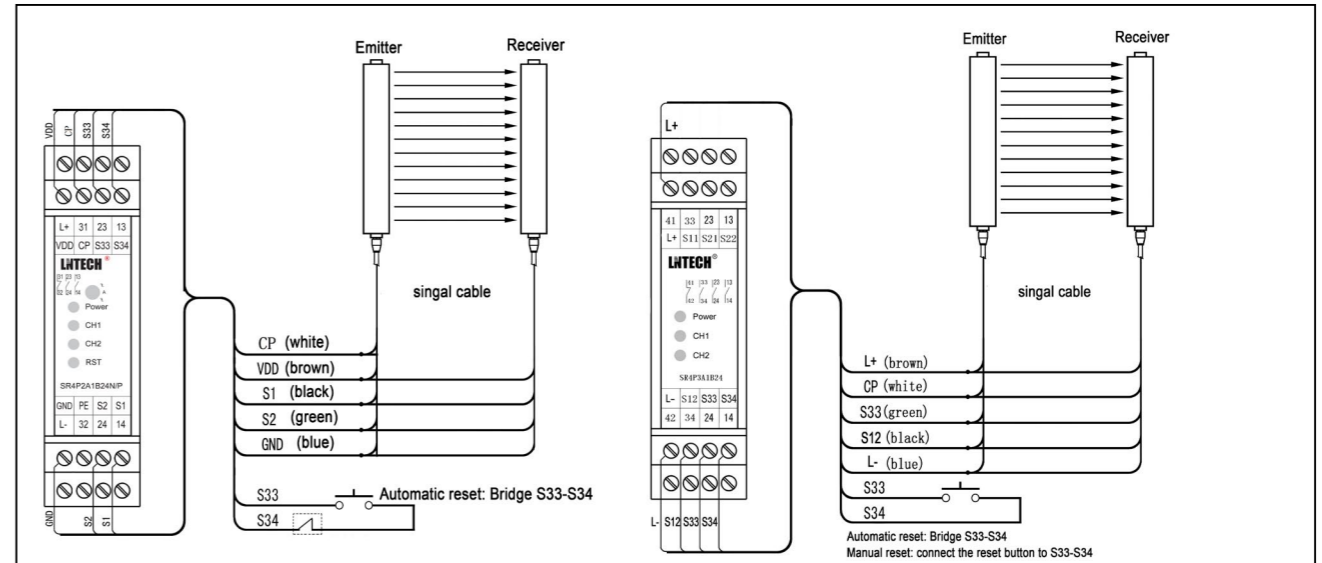

ND型控制器 ND type controller

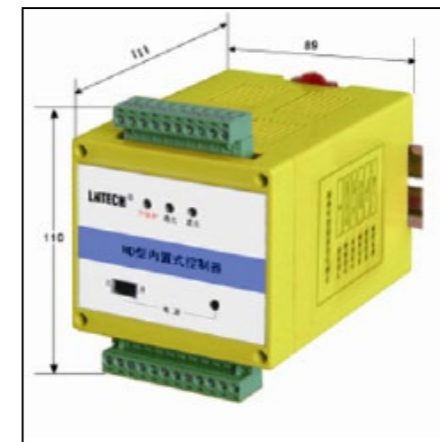

- ◆ Installation position: Inside installation, it can use DIN rail to be installed in electrical cabinet of mechanical equipment ◆ Box material: Plastic.
- ◆ External dimension: height×broad×deep=110×89×111
- ◆ Control cable port: 10P plug terminals ◆ Signal cable port: 12P plug terminals
- ◆ Control light curtain number: 1 set ◆ Input signal form: Double road NPN signal
- ◆ Output signal form: Double relays security signal output, 2 open
- ◆ Output contact capacity: AC250V/DC30V, 5A (cosΦ=0.3)
- ◆ Operating power: AC220V/110V±15% 50/60Hz or DC24V
- ◆ Power consumption: <15W
- ◆ Self-checking function: For the signal processing electric circuit and the output contact carry on monitoring, if the exceptional instance is detected, the output state locks in "fault" immediately, until trouble remove.
- ◆ Self-locking function: The self-locking function is set, the reset switch posts are reserved.
- ◆ Restrain function: If you don't use the optic-electronic protection device, you can short sub B1, B2 terminals in the condition of supplying power; Please use carefully.

- ◆ 安放位置: 内置式, 可利用DIN轨道安装在机械设备的电气柜内
- ◆ 材料: 塑料
- ◆ 外形: 高×宽×深 = 110×89×111
- ◆ 控制电缆接口: 10P插接端子
- ◆ 信号电缆接口: 12P插接端子
- ◆ 控制光幕数量: 1套
- ◆ 输入信号形式: 双路NPN信号
- ◆ 输出形式: 双继电器安全信号输出, 两常开
- ◆ 输出触点容量: AC250V/DC30V, 5A (cosφ=0.3)
- ◆ 工作电源: AC220V/110V±15% 50/60Hz或DC24V
- ◆ 功耗: <15W
- ◆ 自检功能: 对信号处理电路、继电器触点进行监控, 如发现异常, 将输出状态锁定在“故障状态”, 直至故障排除
- ◆ 自锁功能: 可设置自锁功能, 预留复位开关接点
- ◆ 抑制功能: 如不使用光电保护装置, 可在通电状态下短接B1、B2端子, 请谨慎使用

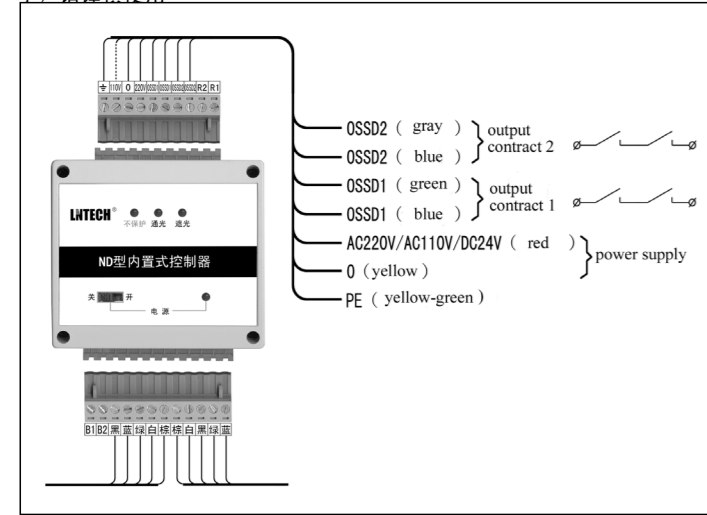

- ◆ For ND controller, there are 3 terminals to be used, they are "220V"/"0"/"110V" respectively, and according to the actual input voltage, connect corresponding terminals.
- ◆ AC220V/110V (red line) and 0 (yellow line) are the AC power supply wires; If the power source need to be DC24V, the special explanation should be made on order.
- ◆ PE (yellow-green) is ground wire
- ◆ OSSD1 (green line and the blue line), OSSD2 (gray line and white line) is output contacts attachment wires. When the light passing, OSSD1/OSSD2 are closed; When the light interrupting, OSSD1/OSSD2 are opened;
- ◆ Retaining R1, R2 two terminals, in order to set up the "self-locking function"; In the factory settings, R1/R2 already short sub; If you need to set up this function, the special explanation should be made on order;
- ◆ If you need other forms of output, for example the output of normal close, special explanation should be made on order.

- ◆ ND型控制器供电输入设置“220V”、“0”、“110V”三个端子, 根据实际输入电压, 接相应端子
- ◆ AC220V/110V (红色线) 和0 (黄色线) 为交流电源输入引线; 如需DC24V电源输入, 请在订货时特别说明
- ◆ PE (黄绿色线) 为接地线
- ◆ OSSD1 (绿色线和蓝色线)、OSSD2 (灰色线和白色线) 为输出接点连线, 光幕透光时, OSSD1、OSSD2接通, 光幕遮光时, OSSD1、OSSD2断开
- ◆ 预留了R1、R2两个端子, 便于设置“自锁功能”; 出厂时, R1、R2已短接; 如需设置该功能, 请订货时特别说明
- ◆ 如需其它输出形式, 比如常闭输出时, 请订货时特别说明

WD型控制 WD controller



- ◆ Installation position: Outside installation, match with fixed bracket, installed directly to the main body of mechanical equipment.
- ◆ Box material: Steel plate, spraying paint on the surface.
- ◆ External dimension: height×broad×deep=241×80×205
- ◆ Control cable: 2.5m, 7×0.5RVV
- ◆ Signal cable port: Aviation plugin (reflection-type with 1, direct transmission type with 2)
- ◆ Control light curtain number: 1 set
- ◆ Input signal form: Double NPN Signal
- ◆ Output signal form: Double relays security signal output, 2 open
- ◆ Output contact capacity: AC250V/DC30V, 5A (cosφ=0.3)
- ◆ Operating power: AC220V/110V±15% 50/60Hz or DC24V
- ◆ Power consumption: <15W
- ◆ Self-checking function: For the signal processing electric circuit and the output contract carry on monitoring, if the exceptional instance is detected, the output state locks in "fault" immediately, until trouble remove. The self-checking switch is established, it may be used manual self-checking.
- ◆ Self-locking function: The self-locking function is set, the reset switch posts are reserved.
- ◆ Return no protection function: If security allow, it can match with electric equipment of machine tool, to realize the return no protection function.

- ◆ 安放位置: 外置式, 配固定支架, 直接安装在机械设备主体上
- ◆ 材料: 钢板, 表面喷塑
- ◆ 外形: 高×宽×深 = 241×80×205
- ◆ 控制电缆: 2.5m, 7×0.5RVV
- ◆ 信号电缆接口: 航空插件 (反射式配1个, 对射式配2个)
- ◆ 控制光幕数量: 1套
- ◆ 输入信号形式: 双路NPN信号
- ◆ 输出形式: 双继电器安全信号输出, 两常开
- ◆ 输出触点容量: AC250V/DC30V, 5A (cosφ=0.3)
- ◆ 工作电源: AC220V/110V±15% 50/60Hz 或 DC24V
- ◆ 功耗: <15W
- ◆ 自检功能: 对信号处理电路、继电器触点进行监控, 如发现异常, 将输出状态锁定在“故障状态”, 直到故障排除; 增设了自检开关, 可手动自检
- ◆ 自锁功能: 可根据要求设置自锁功能, 预留复位开关接点
- ◆ 回程不保护功能: 如安全允许, 可与机床电器配合, 实现回程不保护功能

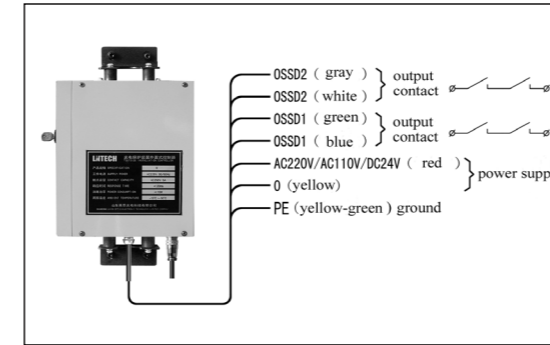

- ◆ In the factory settings, WD type controller's power source is setted for AC220V; if the power supply is AC110V, you should turn on the controller lid, and find the chang-over switch on the electric circuit, and then dial to "110V" position.
- ◆ AC220V/110V (red line) and 0 (yellow line) are the AC power supply wires; If the power source need to be DC24V, the special explanation should be made on order.
- ◆ PE (yellow-green) is ground wire
- ◆ OSSD1 (green line and the blue line), OSSD2 (gray line and white line) is output contacts attachment wires. When the light passing, OSSD1/OSSD2 are closed; When the light interrupting, OSSD1/OSSD2 are opened;
- ◆ If the self-locking function is need to be setted, the special explanation should be made on order, in order to set this function before leaving factory

- ◆ 出厂时, WD型控制器供电电源设置为AC220V, 如供电电源为AC110V, 只需打开控制器盖, 在电路板上找到转换开关拨至“110V”位置即可
- ◆ AC220V/110V (红色线) 和0 (黄色线) 为交流电源输入引线; 如需DC24V输入, 请在订货时特别说明
- ◆ PE (黄绿色线) 为接地线
- ◆ OSSD1 (绿色线和蓝色线)、OSSD2 (灰色线和白色线) 为输出接点连线, 光幕透光时, OSSD1、OSSD2接通, 光幕遮光时, OSSD1、OSSD2断开
- ◆ 如需设置“自锁功能”, 订货时请特别说明, 以便出厂前设置此功能, 并预留复位开关接点

装置规格一览表和外形尺寸 Specification

Light axis pitch 40mm				Light axis pitch 30mm				Light axis pitch 20mm			
Beams	Specification	A	H	Beams	Specification	A	H	Beams	Specification	A	H
04	SND (E) 0440	225	120	06	SND (E) 0630	245	150	06	SND (E) 0620	185	100
06	SND (E) 0640	305	200	08	SND (E) 0830	305	210	08	SND (E) 0820	225	140
08	SND (E) 0840	385	280	10	SND (E) 1030	365	270	10	SND (E) 1020	265	180
10	SND (E) 1040	465	360	12	SND (E) 1230	425	330	12	SND (E) 1220	305	220
12	SND (E) 1240	545	440	14	SND (E) 1430	485	390	14	SND (E) 1420	345	260
14	SND (E) 1440	625	520	16	SND (E) 1630	545	450	16	SND (E) 1620	385	300
16	SND (E) 1640	705	600	18	SND (E) 1830	605	510	18	SND (E) 1820	425	340
18	SND (E) 1840	785	680	20	SND (E) 2030	665	570	20	SND (E) 2020	465	380
20	SND (E) 2040	865	760	22	SND (E) 2230	725	630	22	SND (E) 2220	505	420
22	SND (E) 2240	945	840	24	SND (E) 2430	785	690	24	SND (E) 2420	545	460
24	SND (E) 2440	1025	920	26	SND (E) 2630	845	750	26	SND (E) 2620	585	500
26	SND (E) 2640	1105	1000	28	SND (E) 2830	905	810	28	SND (E) 2820	625	540
28	SND (E) 2840	1185	1080	30	SND (E) 3030	965	870	30	SND (E) 3020	665	580
30	SND (E) 3040	1265	1160	32	SND (E) 3230	1025	930	32	SND (E) 3220	705	620
32	SND (E) 3240	1345	1240	34	SND (E) 3430	1085	990	34	SND (E) 3420	745	660
34	SND (E) 3440	1425	1320	36	SND (E) 3630	1145	1050	36	SND (E) 3620	785	700
36	SND (E) 3640	1505	1400	40	SND (E) 4030	1265	1170	40	SND (E) 4020	865	780
40	SND (E) 4040	1665	1560	44	SND (E) 4430	1385	1290	44	SND (E) 4420	945	860
44	SND (E) 4440	1825	1720	48	SND (E) 4830	1505	1410	48	SND (E) 4820	1025	940
48	SND (E) 4840	1985	1880	52	SND (E) 5230	1625	1530	52	SND (E) 5220	1105	1020
52	SND (E) 5240	2145	2040	56	SND (E) 5630	1745	1650	56	SND (E) 5620	1185	1100
56	SND (E) 5640	2305	2200	60	SND (E) 6030	1865	1770	60	SND (E) 6020	1265	1180
60	SND (E) 6040	2465	2360	64	SND (E) 6430	1985	1890	64	SND (E) 6420	1345	1260
64	SND (E) 6440	2625	2520	68	SND (E) 6830	2105	2010	68	SND (E) 6820	1425	1340
68	SND (E) 6840	2785	2680	72	SND (E) 7230	2225	2130	72	SND (E) 7220	1505	1420
72	SND (E) 7240	2945	2840								

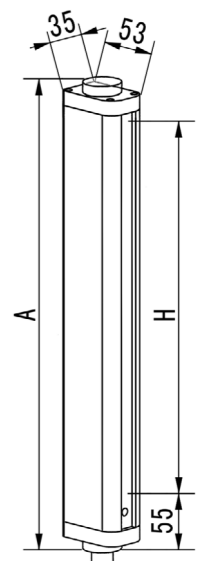

发、受光器
Emitter/receiver

相关的安全标准及指令 Related safety standards and directives

SND (E) 系列光电保护装置符合下列标准和指令：

SND(E) series light curtain complies with the following standards and directives:

Directives 指令	No.	编号
EN ISO 13849-1	Safety of machinery -- Safety-related parts of control systems -- Part 1: General principles for design	机械安全控制系统有关安全部件第1部分：设计通则
EN 61496-1	Machinery safety-Electro-sensitive protective equipment-Part 1:General requirements and tests	机器安全性-电敏防护设备-第1部分：一般要求和试验
IEC/pr EN 61496-2	Machinery safety-Electro-sensitive protective equipment-Part 2: Active opto-electronic protective devices	机器安全性-电敏防护设备-第2部分：主动光电防护设备
EN 60204-1	Machinery safety - Machinery electrical equipment	机器安全性-机械的电气设备
EN ISO 12100-1	Safety of machinery - Basic concepts, general principles for design - Part 1: Basic terminology, methodology	机器安全性-基本概念、设计通则-第一部分：基本术语、方法学
EN ISO 12100-2	Safety of machinery - Basic concepts, general principles for design - Part 2: Technical principles	机器安全性-基本概念、设计通则-第二部分：技术原则与规范
EN ISO 14121-1	Safety of machinery - Risk assessment - Part 1: Principles	机器安全性-风险评估-第一部分：原则
IEC 61508-1...-7	Functional safety of electrical/electronic/programmable electronic safety-related systems	电气 电子 可编程电子安全相关系统的功能安全
EN 62061	IEC 62061: Safety of machinery - Functional safety of electrical, electronic and programmable control systems	机械安全. 与安全有关的电气、电子和可编程序电子控制系统的功能安全
EN 292	Safety of machinery; basic concepts, general principles for design	机器安全性-基本概念、一般设计原则
EN 999	Safety of machinery - The positioning of protective equipment in respect of approach speeds of parts of the human body	机器安全性-人体各部接近速度有关的防护设备的定位
EN 13857	Safety of machinery -- Safety distances to prevent hazard zones being reached by upper and lower limbs	机器安全性-防止上下肢触及危险区的安全距离
EN 692	Machine Security - Mechanical Press	《机床安全性-机械压力机》
EN 693	Machine Security - Hydraulic Press	《机床安全性-液压机》
EN 201	Injection Molding Machine	《注塑机》

安全等级分类

等级	要求摘要	风险评估	安全原则
B	控制电路设计、选择和安装必须使用符合基本安全准则和相关标准的安全开关电器，并且可以承受预期的运行强度，能够承受运行过程中工作介质的影响和相关外部环境的影响	a. 单个故障会导致安全功能的丧失 b. 故障不会被检测出来	通过采用适当元器件来实现
1	在等级B的基础上，必须使用技术成熟的、具有安全功能保证的元器件和原理	同等级B，但由于使用了技术成熟元器件，其对故障的承受能力比等级B更强一些	
2	符合等级B和1的要求，同时必须能够在适当的时间（如启动时，危险状态出现前或运行中），在机器控制系统中对安全控制系统进行测试	a. 一个故障会导致安全功能的丧失 b. 故障可以通过监测被检查出来	通过电路结构设计来实现
3	符合等级B和1的要求，控制系统必须按照以下步骤设计： a. 控制系统中单一的故障不会导致安全功能的丧失 b. 在下次安全功能起作用前或起作用时，必须能够检测到已经存在的故障	a. 一个故障不会导致安全功能的丧失 b. 一些但不是所有的故障都可以被监测出来 c. 一个累积的监测不出的故障能够导致安全功能的丧失	
4	符合等级B和1的要求，控制系统必须按照以下步骤设计： a. 控制系统中单一元器件故障不会导致安全功能的丧失 b. 如果可能，在下一个安全功能实施前，单一故障可以被检测出来 c. 如果b不可能实现，要求故障的累积不会导致安全功能的失效	a. 在故障出现的时候，安全功能总是保持 b. 故障会被及时检测出来，以防止安全功能的丢失	

Specification of safety categories

Category	Requirements (in brief)	System Behaviour	Principle
B	Safety-related parts of control systems and/or their safety devices and their components must be designed, constructed, selected, assembled and combined in accordance with the relevant standards such that they can withstand the expected influence.	The occurrence of a fault can lead to the loss of the safety function.	Mainly Characterized by the selection of components.
1	The requirements of B shall apply. Well-tried components and well-tried safety principles shall be used.	The occurrence of a fault can lead to the loss of the safety function, but the probability of occurrence is lower than in category B.	
2	The requirements of B and the use of well-tried safety principles shall apply. The safety function shall be checked at suitable intervals by the machinery control system.	The occurrence of a fault can lead to the loss of the safety function between the checks. The loss of the safety function is detected by the check.	Mainly characterized by the structure.
3	The requirements of B and the use of well-tried safety principles shall apply. Safety-related parts shall be designed such that: 1. a single fault in any of these parts does not lead to the loss of the safety function, and 2. the single fault is detected whenever reasonably practicable.	If the single fault occurs, the safety function is still maintained. Some, but not all faults are detected. Accumulation of undetected faults can lead to the loss of the safety function.	
4	The requirements of B and the use of well-tried safety principles shall apply. Safety-related parts shall be designed such that: 1. a single fault in any of these parts does not lead to the loss of the safety function, and 2. the single fault is detected during or prior to the next demand on the safety function, or, if this is not possible, an accumulation of faults should not as a result lead to the loss of the safety function.	If faults occur, the safety function is still maintained. Faults are detected in good time to prevent the loss of the safety function.	



山东莱恩光电科技有限公司
Shandong Laien Optic-electronic Technology CO.,LTD.

电话 Tel : 0537-3169808, 3169707

传真 Fax: 0537-3166661

总部服务热线 Headquarters service hotline: 400-6183915

地址 : 山东济宁高新区济邹科技园山博路西首

Address: West ShanBo Road, Jizhou Science&Tech Park, New&High-tech Zone, Jining, ShanDong

网址 Http: www.laien.cn E-mail: ln100@laien.cn

佛山(Foshan)	0757-26394257	13827754616	FAX: 26607129
深圳(Shenzhen)	0755-21312516	13603098134	FAX: 28091503
宁波(Ningbo)	0574-87283600	15888515816	FAX: 87147900
苏州(Suzhou)	0512-65808355	18605126723	FAX: 67519537
沈阳(Shenyang)	024-25610161	13889876831	FAX: 25610161
扬州(Yangzhou)	0514-89787637	18605379628	FAX: 89787637
上海(Shanghai)	021-67613053	13761559985	FAX: 67613053
天津(Tianjin)	022-86676076	15822999788	FAX: 86676076
武汉(Wuhan)	027-84288298	13971629756	FAX: 84288298
重庆(Chongqing)	023-68066760	15123959592	FAX: 68066760
青岛(Qingdao)	0532-87767585	18653290543	FAX: 87767585
合肥(Hefei)	0551-6700103	13665602610	FAX: 6700103
长沙(Changsha)	0772-2605391	18648888286	FAX: 2605391
温州(Wenzhou)	0577-65646558	13685875798	FAX: 65646558
厦门(Xiamen)	0592-6314963	18759287521	FAX: 6314963

为安全生产服务

Server safety in production

因为专业，所以可靠！因为可靠，所以我们承诺：LNTECH产品三包期为18个月

Because specialty, so reliable! Because reliable, so we promise: LNTECH product guarantee period are 18 months