



# 产 品 规 格 书

## SPECIFICATION

产 品 名 称	石英晶体谐振器 QUARTZ CRYSTAL UNITS
型 号	YSX531SL
料 号	X503212MSD4SC
标 称 频 率	12.000MHZ-20PF
页 次	共 6 页

### 深圳扬兴科技有限公司

YangXing Technology Co.,Ltd.of Shenzhen

地址: 广东省深圳市福田区中航路鼎诚国际大厦2013-2014室  
ADDRESS: Futian District, Shenzhen, Guangdong Province, route Ding Cheng  
International Building Room 2013-2014

TEL: 0755-28444777

POSTCODE: 518031

FAX: 0755-28444777-812

E-MAIL: sales@yangxing.hk

\*\*\*\*\*

批 准	审 核	拟 制
Kevin	Sandy	HQY

## 确 认 签 章

### APPROVAL SIGNATURE

客 户		
客户物料号		
机种 / 型号		
批 准	审 核	检 验

# 深圳扬兴科技有限公司

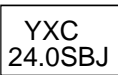
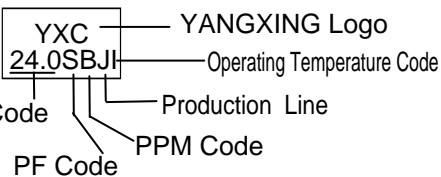
产品规格书/ SPECIFICATION	型号	YSX531SL
<b>I 晶振电性能 Electrical Characteristics</b>		
1. 标称频率 Nominal Frequency	12.000	MHZ
2. 振动模式 Mode of vibration	基频 / AT 切	
3. 工作温度范围 Operating Temperature Range	- 20 °C ~ + 70 °C	
4. 保存温度范围 Storage Temperature Range	-40°C ~ +85°C	
5. 频率偏差 Adjustment Tolerance	± 20 ppm Max	
6. 温度偏差 Tolerance over the Temperature Range	± 20 ppm Max	
7. 等效电阻 Equivalent Series Resistance	80 Ω Max. at 25°C	
8. 静电容 Shunt Capacitance	7.0 pF Max	
9. 气密性测试 Leakage	Gross Leak:	1.3*10 <sup>-5</sup> Pa.m <sup>3</sup> /s Max
	Fine Leak:	2.1*10 <sup>-9</sup> Pa.m <sup>3</sup> /s Max
10. 老化率 Aging	± 3ppm Max/Y	
11. 标字 Marking	<div style="display: flex; align-items: center; justify-content: space-around;"> <div style="text-align: center;"> <p>1. </p> </div> <div style="text-align: center;"> <p>2. </p> </div> </div>	
12. 外形尺寸 Dimensions	5.0*3.2*0.90mm	
<b>II. 测试条件 Test Condition</b>		
1. 负载电容 Load Capacitance	20 pF	
2. 激励功率 Level of Drive	100 μ W	
3. 测试仪表 Equipment	250B Crystal Impedance Meter	
<b>RK-0869</b>	YangXing Technology Co.,Ltd.of Shenzhen	

# 深圳扬兴科技有限公司

产品规格书/ SPECIFICATION	型号	YSX531SL
<p>III. 包装 PACKING 包装方式应符合运输和装卸要求，特殊包装须经双方认可。 Packing must prevent damage during transportation and handing. Specific method will be settled by mutual agreement.</p> <p>IV.对环境影响 INFLUENCE TO ENVIRONMENT 本产品在生产过程中不使用 ODS I，对臭氧层无破坏。 This product doesn't use the class I ODS at any of production process .</p> <p>V. 生产厂家 MANUFACTURE 公司名称：<b>深圳扬兴科技有限公司</b> YangXing Technology Co.,Ltd.of Shenzhen 地址：广东省深圳市福田区中航路鼎诚国际大厦2013-2014 室 ADDRESS: Futian District,Shenzhen,Guangdong Proince,route Ding Cheng International Building Room 2013-2014 TEL: 0755-28444777 POSTCODE: 518031 FAX: 0755-28444777-812 E-MAIL: sales@yangxing.hk</p> <p>VI.其它 OTHERS</p> <p>1. 如果您对本公司产品规格书有疑问或书中未列出，请与我方联系，协商解决及改进。 If you have some doubt or unknowing about this specification, Please contact us for settlement or development.</p> <p>2.我们按照产品规格书要求保证晶体品质，若客户要求具体数据，我们可提供。 We guarantee that quartz crystal unit satisfies this specification, If you need the data, we will provide it.</p> <p>3.变更与联络 (MODIFY AND CONTACT) 本产品在设计、工艺、材料、生产场所、关键设备、操作人员等影响产品质量的因素有变更时，应事先提供更改后的产品并经过质量认可后，方可大批量供货。 When the quality is changed due to the changes of the design, technology, material, manufacture place, main equipment and workers, we will first supply the modified products and obtain approval from you, then start to supply mass production.</p> <p>4.售后服务 (AFTER SALE SERVICE) 若在生产过程中遇到不良品，本公司负责调换，并及时提交不良品的分析及改进措施报告经认可。 If the defection product was found in the production process, we will exchange and provide the improving measures in time.</p>		
<b>RK-0869</b>	YangXing Technology Co.,Ltd.of Shenzhen	

# 深圳扬兴科技有限公司

产品规格书/ SPECIFICATION

型号

YSX531SL

VII. SMD5032 晶体外型/编带尺寸 Dimensions UNIT: mm

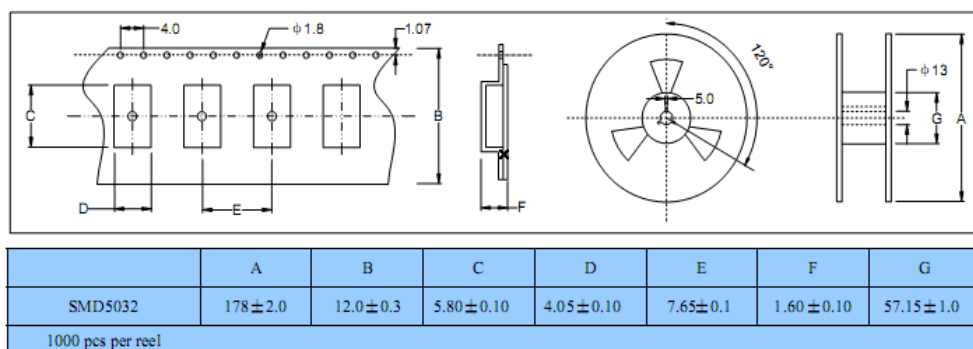
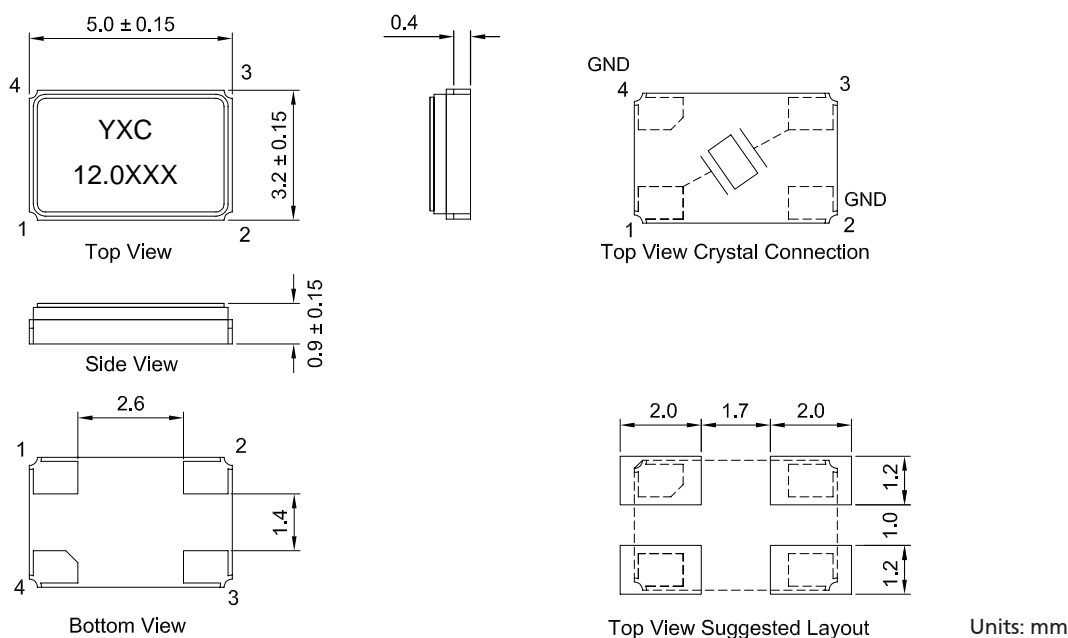

SMD5032 编带尺寸图 (mm)

## 包装 PACKING

每 1000 只晶体进行编带包装，每 1 万只晶体放入一包装盒内。同时，包装形式也依赖于具体数量而更改。

Deposit 1000 pieces of the quartz crystal units in tape model, and pack enough bags in a packing case to make a 10,000 pieces package. The packing format may be subject to change by quantity.

RK-0869

YangXing Technology Co.,Ltd.of Shenzhen

# 深圳扬兴科技有限公司

<b>产品规格书/ SPECIFICATION</b>	<b>型号</b>	YSX531SL
-----------------------------	-----------	----------

## VIII. 可靠性试验项目 Reliability Test Items

### 1. 机械性能试验 Mechanical Performance Tests

试验项目 Test Item	试验方法 Test Method	规格 No. Spec. No
1-1 耐冲击 shock	从 75 厘米高, 3 次, 自由落在 3 厘米的硬木板上 Orient the sample in any attitude and drop it three times from a height of 75 cm onto a hardwood board with a thickness of 3 cm	A
1-2 耐振性 Vibration	振动频率 10~55Hz, 振幅 1.5mm 时间 1.5 分钟循环, 在 X、Y、Z 轴方向各 2 小时, 总计 6 小时。 Subject the sample to 1.5-minute cycles of frequencies of 10 to 55 Hz and amplitudes of 1.5mm for two hours in each of the X,Y, and Z directions, or 6 hours in total.	A
1-3 气密性 Leaking Test	用氦质谱仪测试或加压测绝缘电阻 Take measurements with a helium leakage detector, or measure insulation resistance under pressure.	E

### 2. 回流焊曲线图

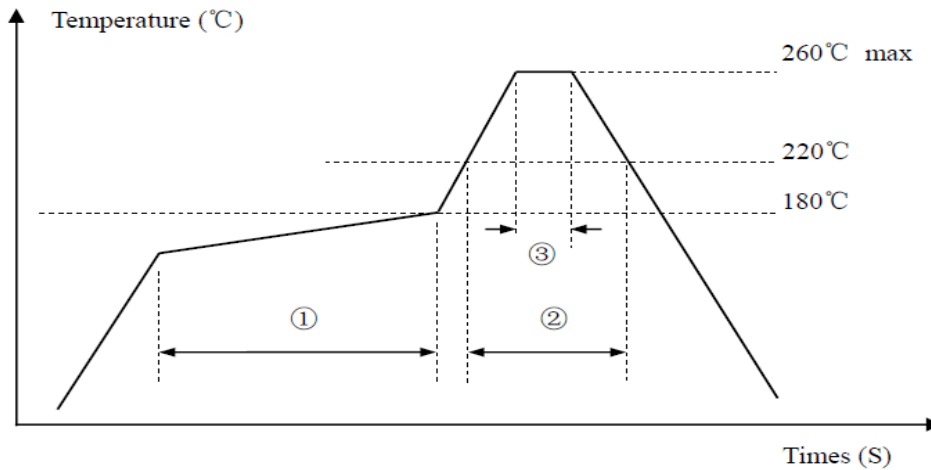

Pb free reflow A	①	Preheat	160~180°C	120sec. max
	②	Primary heat	220°C	60sec. max
	③	Peak	260°C	10sec. max.

**RK-0869**

YangXing Technology Co.,Ltd.of Shenzhen

# 深圳扬兴科技有限公司

<b>产品规格书/ SPECIFICATION</b>	<b>型号</b>	YSX531SL										
<p>VIII. 可靠性试项目      Reliability Test Items</p> <p>3. 环境测试      Environmental Tests</p>												
试验项目 Test Item	试验方法 Test Method	规格 No. Spec. No.										
2-1	耐寒性 Cold 在-30℃环境中非工作状态放置 500 小时 Expose the sample in an inoperative mode to 500 hours in a -30℃	A										
2-2	耐热性 Dry heat 在+85℃环境中非工作状态放置 500 小时 Expose the sample in an inoperative mode to 500 hours in a 85℃	B										
2-3	耐湿性 Damp heat 在温度+65℃，湿度 95%环境中非工作状态放置 500 小时 Expose the sample in an inoperative mode to 500 hours in a 65℃, and 95%RH	B										
2-4	热冲击 Thermal shock 在-30℃保持 30 分钟，100℃保持 30 分钟，循环 5 次。 Subject the sample to 5 temperature variation cycles at -30℃ for 30 minutes and +100℃ for the next 30 minutes in each cycles.	A										
<p><b>SPECIFICATIONS 规格</b></p> <table border="1" style="width: 100%; border-collapse: collapse;"> <thead> <tr> <th style="width: 15%; text-align: center;">规格 No. Spec No.</th> <th style="width: 85%; text-align: center;">规 格 Specification</th> </tr> </thead> <tbody> <tr> <td style="text-align: center;">A</td> <td>试验前后,频率变化在±5ppm 以内,等效电阻变化在要求范围内。 Any variation between the pre- and post-test frequencies shall remain within ±5ppm. The post-test equivalent series resistance shall remain within its specified tolerance range.</td> </tr> <tr> <td style="text-align: center;">B</td> <td>试验前后,频率变化在±10ppm 以内,等效电阻变化在要求范围内。 Any variation between the pre- and post-test frequencies shall remain within ±10ppm. The post-test equivalent series resistance shall remain within its specified tolerance range.</td> </tr> <tr> <td style="text-align: center;">C</td> <td>试验前后,外观未见明显损伤,气密性未破坏。 After each test, no visible damage shall be manifested, nor shall the hermetic seal break down.</td> </tr> <tr> <td style="text-align: center;">D</td> <td><math>1 \times 10^{-2} \mu\text{Pa} \cdot \text{m}^3/\text{s}</math> Max or <math>IR \geq 500\text{M}\Omega</math></td> </tr> </tbody> </table> <p>※测试在室温 <math>25 \pm 2^\circ\text{C}</math> 环境中进行,每次试验后,样品必须在 <math>25 \pm 2^\circ\text{C}</math> 环境中恢复 2 小时以上。</p> <p>※ Measurements shall be taken at <math>25 \pm 2^\circ\text{C}</math>, and after each test, the sample be exposed to two hours at <math>25 \pm 2^\circ\text{C}</math></p>			规格 No. Spec No.	规 格 Specification	A	试验前后,频率变化在±5ppm 以内,等效电阻变化在要求范围内。 Any variation between the pre- and post-test frequencies shall remain within ±5ppm. The post-test equivalent series resistance shall remain within its specified tolerance range.	B	试验前后,频率变化在±10ppm 以内,等效电阻变化在要求范围内。 Any variation between the pre- and post-test frequencies shall remain within ±10ppm. The post-test equivalent series resistance shall remain within its specified tolerance range.	C	试验前后,外观未见明显损伤,气密性未破坏。 After each test, no visible damage shall be manifested, nor shall the hermetic seal break down.	D	$1 \times 10^{-2} \mu\text{Pa} \cdot \text{m}^3/\text{s}$ Max or $IR \geq 500\text{M}\Omega$
规格 No. Spec No.	规 格 Specification											
A	试验前后,频率变化在±5ppm 以内,等效电阻变化在要求范围内。 Any variation between the pre- and post-test frequencies shall remain within ±5ppm. The post-test equivalent series resistance shall remain within its specified tolerance range.											
B	试验前后,频率变化在±10ppm 以内,等效电阻变化在要求范围内。 Any variation between the pre- and post-test frequencies shall remain within ±10ppm. The post-test equivalent series resistance shall remain within its specified tolerance range.											
C	试验前后,外观未见明显损伤,气密性未破坏。 After each test, no visible damage shall be manifested, nor shall the hermetic seal break down.											
D	$1 \times 10^{-2} \mu\text{Pa} \cdot \text{m}^3/\text{s}$ Max or $IR \geq 500\text{M}\Omega$											
<b>RK-0869</b>	YangXing Technology Co.,Ltd.of Shenzhen											