

PREPARED BY: DATE	<h1 style="text-align: center;">SHARP®</h1> <p style="text-align: center;">LIQUID CRYSTAL DISPLAY GROUP SHARP CORPORATION</p>	SPEC No. LCY-W-14Z03
APPROVED BY: DATE		FILE No.
		ISSUE DEC.8th.2014
		PAGE Pages 30
		APPLICABLE DIVISION  DEVELOPMENT DEPT. II DESIGN CENTER II LCD DESIGN DEVELOPMENT DISPLAY DEVICE BUSINESS GROUP SHARP (CHINA) INVESTMENT CO.,LTD.
<b>SPECIFICATION</b>		

DEVICE SPECIFICATION for  
TFT LCD Module  
(1080× RGB × 1920 dots)

Model No.  
**LQ055T3SX02(G)**



CUSTOMER'S APPROVAL

DATE \_\_\_\_\_

BY \_\_\_\_\_

PRESENTED  
BY T. Yamamoto  
TAKAHIRO YAMAMOTO  
DEPARTMENT GENERAL MANAGER  
DEVELOPMENT DEPT. II DESIGN CENTER II  
LCD DESIGN DEVELOPMENT  
DISPLAY DEVICE BUSINESS GROUP  
SHARP (CHINA) INVESTMENT CO.,LTD.



## NOTICE

- These specification sheets are the proprietary product of SHARP CORPORATION (SHARP) and include materials protected under copyright of SHARP. Do not reproduce or cause any third party to reproduce them in any form or by any means, electronic or mechanical, for any purpose, in whole or in part, without the express written permission of SHARP.
- The application examples in these specification sheets are provided to explain the representative applications of the device and are not intended to guarantee any industrial property right or other rights or license you to use them. 1 from the use of the device.
- The device listed in these specification sheets was designed and manufactured for use in Telecommunication equipment (terminals)
- In case of using the device for applications such as control and safety equipment for transportation (aircraft, trains, automobiles, etc. ), rescue and security equipment and various safety related equipment which require higher reliability and safety, take into consideration that appropriate measures such as fail-safe functions and redundant system design should be taken.
- Do not use the device for equipment that requires an extreme level of reliability, such as aerospace applications, telecommunication equipment (trunk lines), nuclear power control equipment and medical or other equipment for life support.
- SHARP assumes no responsibility for any damage resulting from the use of the device which does not comply with the instructions and the precautions specified in these specification sheets.
- Contact and consult with a SHARP sales representative for any questions about this device.

### [For handling and system design]

- (1) Do not scratch the surface of the polarizer film as it is easily damaged.
- (2) If the cleaning of the surface of the LCD panel is necessary, wipe it swiftly with cotton or other soft cloth. Do not use organic solvent as it damages polarizer.
- (3) Water droplets on polarizer must be wiped off immediately as they may cause color changes, or other defects if remained for a long time.
- (4) Since this LCD panel is made of glass, dropping the module or banging it against hard objects may cause cracks or fragmentation.
- (5) Certain materials such as epoxy resin (amine's hardener) or silicone adhesive agent (de-alcohol or de-oxym) emits gas to which polarizer reacts (color change). Check carefully that gas from materials used in system housing or packaging do not hurt polarizer.
- (6) Liquid crystal material will freeze below specified storage temperature range and it will not get back to normal quality even after temperature comes back within specified temperature range. Liquid crystal material will become isotropic above specified temperature range and may not get back to normal quality. Keep the LCD module always within specified temperature range.
- (7) Do not expose LCD module to the direct sunlight or to strong ultraviolet light for long time.
- (8) If the LCD driver IC (COG) is exposed to light, normal operation may be impeded. It is necessary to design so that the light is shut off when the LCD module is mounted.
- (9) Do not disassemble the LCD module as it may cause permanent damage.

(10) As this LCD module contains components sensitive to electrostatic discharge, be sure to follow the instructions in below.

① Operators

Operators must wear anti-static wears to prevent electrostatic charge up to and discharge from human body.

② Equipment and containers

Process equipment such as conveyer, soldering iron, working bench and containers may possibly generate electrostatic charge up and discharge. Equipment must be grounded through 100Mohms resistance. Use ion blower.

③ Floor

Floor is an important part to leak static electricity which is generated from human body or equipment.

There is a possibility that the static electricity is charged to them without leakage in case of insulating floor, so the countermeasure(electrostatic earth: $1 \times 10^8 \Omega$ ) should be made.

④ Humidity

Proper humidity of working room may reduce the risk of electrostatic charge up and discharge. Humidity should be kept over 50% all the time.

⑤ Transportation/storage

Storage materials must be anti-static to prevent causing electrostatic discharge.

⑥ Others

Protective film is attached on the surface of LCD panel to prevent scratches or other damages. When removing this protective film, remove it slowly under proper anti-ESD control such as ion blower.

(11) Hold LCD very carefully when placing LCD module into the system housing. Do not apply excessive stress or pressure to LCD module. Do not to use chloroprene rubber as it may affect on the reliability of the electrical interconnection.

(12) Do not hold or touch LCD panel to flex interconnection area as it may be damaged.

(13) As the binding material between LCD panel and flex connector mentioned in 12) contains an organic material, any type of organic solvents are not allowed to be used. Direct contact by fingers is also prohibited.

(14) When carrying the LCD module, place it on the tray to protect from mechanical damage. It is recommended to use the conductive trays to protect the CMOS components from electrostatic discharge. When holding the module, hold the Plastic Frame of LCD module so that the panel, COG and other electric parts are not damaged.

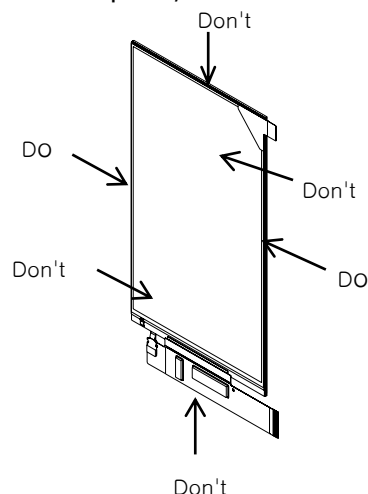

(15) Do not touch the COG's patterning area. Otherwise the circuit may be damaged.

(16) Do not touch LSI chips as it may cause a trouble in the inner lead connection.

(17) Place a protective cover on the LCD module to protect the glass panel from mechanical damages.

(18) LCD panel is susceptible to mechanical stress and even the slightest stress will cause a color change in background. So make sure the LCD panel is placed on flat plane without any continuous twisting, bending or pushing stress.

(19) Protective film is placed onto the surface of LCD panel when it is shipped from factory. Make sure to peel it off before assembling the LCD module into the system. Be very careful not to damage LCD module by electrostatic discharge when peeling off this protective film. Ion blower and ground strap are recommended.

(20) Make sure the mechanical design of the system in which the LCD module will be assembled matches specified viewing angle of this LCD module.

(21) This LCD module does not contain nor use any ODS (1,1,1-Trichloroethane, CCL4) in all materials used, in all production processes.

### [For operating LCD module]

- (1) Do not operate or store the LCD module under outside of specified environmental conditions.
- (2) At the shipment, adjust the contrast of each LCD module with electric volume. LCD contrast may vary from panel to panel depending on variation of LCD power voltage from system.
- (3) As opt-electrical characteristics of LCD will be changed, dependent on the temperature, the confirmation of display quality and characteristics has to be done after temperature is set at 25 °C and it becomes stable.

### [Precautions for Storage]

- (1) Do not expose the LCD module to direct sunlight or strong ultraviolet light for long periods. Store in a dark place.
- (2) The liquid crystal material will solidify if stored below the rated storage temperature and will become an isotropic liquid if stored above the rated storage temperature, and may not retain its original properties. Only store the module at normal temperature and humidity (25±5°C, 60±10%RH) in order to avoid exposing the front polarizer to chronic humidity.
- (3) Keeping Method
  - a. Don't keeping under the direct sunlight.
  - b. Keeping in the tray under the dark place.

## DON'T

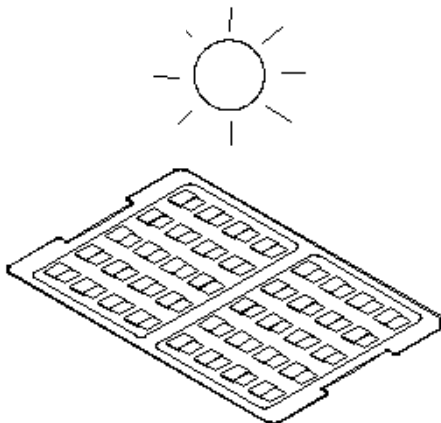

## DO

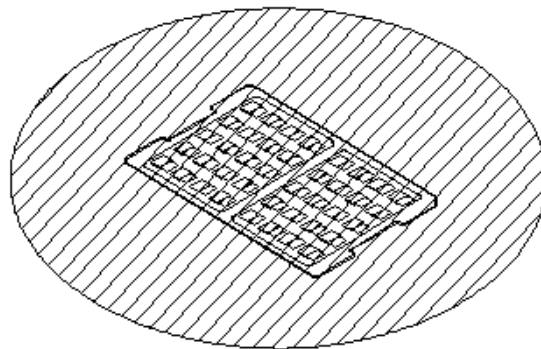

- (4) Do not operate or store the LCD module under outside of specified environmental conditions.
- (5) Be sure to prevent light striking the chip surface.

### [Other Notice]

- (1) Do not operate or store the LCD module under outside of specified environmental conditions.
- (2) As electrical impedance of power supply lines (VDDI/VSP/VSN) are low when LCD module is working, place the de-coupling capacitor nearby LCD module as close as possible.
- (3) Reset signal must be sent after power on to initialize LSI. LSI does not function properly until initialize it by reset signal.
- (4) Generally, at power on, in order not to apply DC charge directly to LCD panel, supply logic voltage first and initialize LSI logic function including polarity alternation. Then supply voltage for LCD bias. At power off, in order not to apply DC charge directly to LCD panel, execute Power OFF sequence and Discharge command.
- (5) Don't touch to FPC surface, exposed IC chip, electric parts and other parts, to any electric, metallic materials.
- (6) No bromide specific fire-retardant material is used in this module.
- (7) Do not display still picture on the display over 2 hours as this will damage the liquid crystal.
- (8) The connector used in this LCD module is the one Sharp have not ever used. Therefore, please note that the quality of this connector concerned is out of Sharp's guarantee.
- (9) Be sure to use a power supply with the safety protection circuit such as the fuse for excess voltage, excess current, electric discharge waveform and Latch-up occurring.
- (10) Epoxy resin (amine series curing agent), silicone adhesive material (dealcoholization series and oxime series), tray forming agent (azo compound) etc, in the cabinet or the packing materials may induce abnormal display with polarizer film deterioration regardless of contact or noncontact to polarizer film.  
Be sure to confirm the component of them.
- (11) This module is designed for OCA TP bonding. If you are changing TP system, please contact us.

### [Precautions for Discarding Liquid Crystal Modules]

COG: After removing the LSI from the liquid crystal panel, dispose of it in a similar way to circuit boards from electronic devices.

LCD panel: Dispose of as glass waste. This LCD module contains no harmful substances. The liquid crystal panel contains no dangerous or harmful substances. The liquid crystal panel only contains an extremely small amount of liquid crystal (approx.100mg) and therefore it will not leak even if the panel should break.

Its median lethal dose (LD50) is greater than 2,000 mg/kg and a mutagenetic (Aims test: negative) material is employed.

FPC: Dispose of as similar way to circuit board from electric device.

## **1. Application**

This data sheet is to introduce the specification of LQ055T3SX02(G) active matrix 16,777,216color LCD module. Main color LCD module is controlled by Driver IC(NT35532).

If any problem occurs concerning the items not stated in this specification, it must be solved sincerely by both parties after deliberation.

As to basic specification of driver IC refer to the IC specification and handbook.

## **2. Construction and Outline**

Construction: LCD panel, Driver (COG), FPC with electric components, 12 White LED lump, prism sheet, diffuser, light guide and reflector, plastic frame to fix them mechanically.

Outline: See page 28

Connection: ZIF connector (HIROSE,FH26-39S-03SHW)

There shall be no scratches, stains, chips, distortions and other external drawbacks that may affect the display function.

In order to realize thin module structure, double-sided adhesive tapes are used to fix LCD panels. As these tapes do not guarantee to permanently fix the panels, LCD panel may rise from the module when shipped from factory. So please make sure to design the system to hold the edges of LCD panel by the soft material such as sponge when LCD module is assembled into the cabinet.

## **3. Mechanical Specification**

Table 1

Parameter		Specifications	Unit
Outline dimensions (typ)		70.84 (W)×128.56 (H)×1.5(D) *2	mm
Main LCD Panel	Active area	68.04(W)×120.96(H)	mm
	Display format	1080(W) × RGB × 1920(H)	-
	Dot pitch	0.021(W)×0.063 (H)	mm
	Base color *1	Normally Black	-
	Illumination mode	Transmissive	
Mass		About:23	g

\*1 Due to the characteristics of the LC material, the colors vary with environmental temperature.

\*2 The above-mentioned table indicates module sizes without some projections and FPC.

## 4. Electrical Absolute Maximum Ratings

Table 2

Ta=25 °C

Parameter	Symbol	Conditions	Rated value	Unit	Remarks
Driver IC (Positive Analog) Power Supply Voltage	VSP – AGND	Ta=+25°C	-0.3 ~ +6.5	V	【Note4-1】
Driver IC (Negative Analog) Power Supply Voltage	AGND – VSN	Ta=+25°C	-6.5 ~ 0.3	V	【Note4-1】
Driver IC (Digital) Power Supply Voltage	VDDI – GND	Ta=+25°C	-0.3 ~ +4.6	V	【Note4-1】
LED Forward Current	I <sub>F</sub>	Ta=+25°C	30	mA	
LED Peak Pulsed Forward Current	I <sub>FM</sub>	Ta=+25°C	60	mA	【Note4-2】
LED Reverse Voltage	V <sub>R</sub>	Ta=+25°C	5	V	
LED Operating Temperature	T <sub>opr</sub>	-	-30 to +85	°C	
LED Storage Temperature	T <sub>stg</sub>	-	-40 to +90	°C	
LED Soldering Temperature	T <sub>sol</sub>	-	260	°C	

【Note4-1】Voltage applied to GND pins. GND pin conditions are based on all the same voltage (0V).

Always connect all GND externally and use at the same voltage.

【Note4-2】Duty ratio = 1/10, Pulse width = 0.1msec

## 5. Environment Conditions

Table 3

Item	Top		Tstg		Remark
	MIN.	MAX.	MIN.	MAX.	
Ambient temperature	-20 °C	+60°C	-30 °C	+70°C	【Note5-1】
Humidity	【Note5-1】		【Note5-1】		No condensation

【Note5-1】Humidity:95%RHMax.(at Ta≤40°C). Maximum wet-bulb temperature is less than 39°C (at Ta>40°C).

Condensation of dew must be avoided.

As opt-electrical characteristics of LCD will be changed, dependent on the temperature, the confirmation of display quality and characteristics has to be done after temperature is set at 25 °C and it becomes stable.

Be sure not to exceed the rated voltage, otherwise a malfunction may occur.



## 6. Electrical Specifications

### (6-1) Power Supply Voltage Range

Table 4

Parameter	Symbol	Min.	Typ.	Max.	Unit	Remarks
Driver IC(Analog) Power Supply Voltage	VSP	5.65V	5.8V	5.95V	V	【Note6-1】
Driver IC(Analog) Power Supply Voltage	VSN	-5.75V	-5.6V	-5.45V	V	【Note6-1】
Driver IC(Digital) Power Supply Voltage	VDDI	1.7V	1.8V	1.9V	V	【Note6-1】

### (6-2) DC characteristics

Table 5

Parameter	Symbol	Min.	Typ.	Max.	Unit	Remarks
Logic High level input voltage	VIH	0.7 VDDI	-	VDDI	V	【Note6-1,2】
Logic Low level input voltage	VIL	VSS	-	0.3VDDI	V	【Note6-1,2】
Logic High level output voltage	VOH	0.8 VDDI		VDDI	V	【Note6-1,2,3】
Logic Low level output voltage	VOL	VSS		0.2 VDDI	V	【Note6-1,2,3】
Logic High level leakage MIPI	ILIH			10	μA	Vin = 0 to 1.3 V
Logic Low level leakage MIPI	ILIL	-10			μA	Vin = 0 to 1.3 V
Current consumption	I <sub>VSP</sub>	-	9.3	14.0	mA	【Note6-4】
	I <sub>VSN</sub>		9.9	14.8	mA	【Note6-4】
	I <sub>IOVCC</sub>	-	21.8	32.7	mA	【Note6-4】

【Note6-1】 The DC/AC electrical characteristics of Module are guaranteed at -20° C ~ +60° C.

【Note6-2】 When the measurements are performed with LCD module, Measurement Points are like below.  
RES,TE and LEDPWM.

【Note6-3】 IOH = -0.1mA IOL = +0.1mA

【Note6-4】 Measurement Conditions : Full screen white pattern, VSP=5.8V, VSN=-5.6V ,VDDI=1.8V, 60Hz Refresh

(6-3) MIPI DSI characteristics

<DC characteristics>

Table6

Ta=+25°C, GND=0V

Symbol	Parameter	Min	Typ	Max	Unit
Power and Operation Voltage for MIPI Receiver					
VDDI	Power supply voltage for MIPI RX	1.7	1.8	1.9	V
VP_HSSI	High speed / Low power mode operating voltage		1.62		V
MIPI Characteristics for High Speed Receiver					
VILHS	Single-ended input low voltage	-40			mV
VIHHS	Single-ended input high voltage			460	mV
VCMRXDC	Common-mode voltage	70		330	mV
ZID	Differential input impedance	80	100	125	ohm
VOD	HS transmit differential voltage (VOD=VDP-VDN)	140	200	250	mV
V <sub>IDTH</sub>	Different input high threshold			70	mV
V <sub>IDTL</sub>	Different input low threshold	-70			mV
V <sub>TERM-EN</sub>	Single-ended threshold for HS termination enable			450	mV
MIPI Characteristics for Low Power Mode					
VI	Pad signal voltage range	-50		1350	mV
VGNDSH	Ground shift	-50		50	mV
VIL	Logic 0 input threshold	0.0		550	mV
VIH	Logic 1 input threshold	880		VDDAM	mV
VHYST	Input hysteresis	25			mV
VOL	Output low level	-50		50	mV
VOH	Output high level	1.1	1.2	1.3	V
ZOLP	Output impedance of Low Power Transmitter	80	100	125	ohm
VIHCD,MAX	Logic 0 contention threshold	0.0		200	mV
VILCD,MIN	Logic 1 contention threshold	450		VDDAM	mV

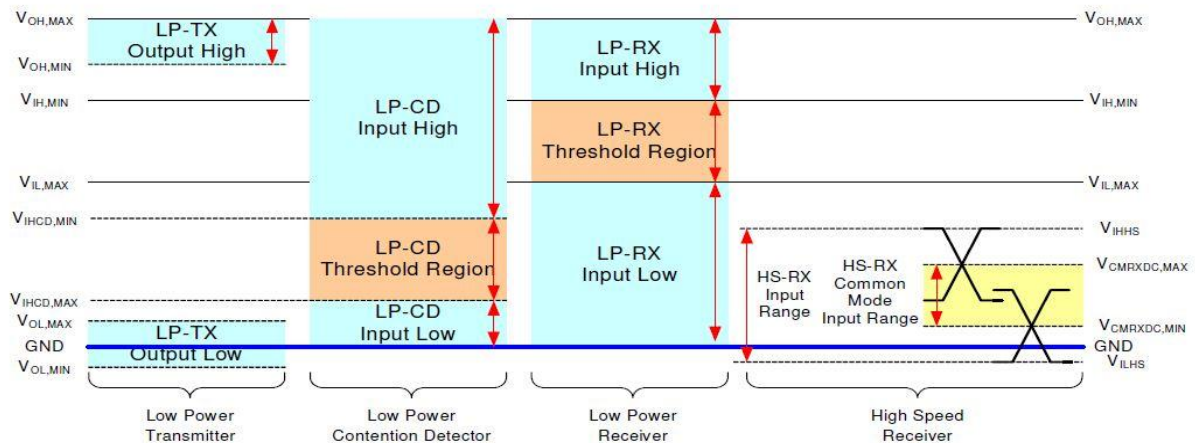

Fig.1

<AC Characteristics>  
MIPI Interface Characteristics  
High Speed Data Transmission: Data-Clock Timing

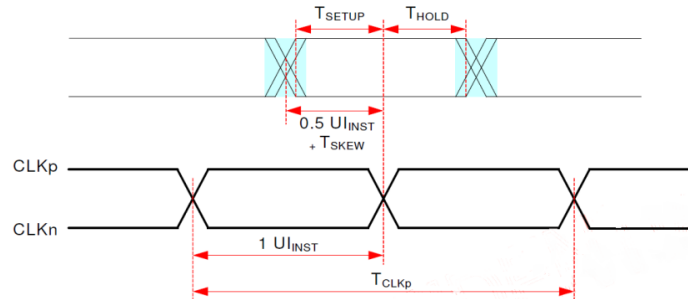

Fig.2

Table 7

Ta=+25°C, GND=0V

Parameter	Symbol	Min	Typ	Max	Units	Notes
UI instantaneous	UI <sub>INST</sub>	1		12.5	ns	1,2,10
Data to Clock Skew [measured at transmitter]	T <sub>SKEW</sub> [TX]	-0.15		0.15	UI <sub>INST</sub>	3
		-0.2		0.2	UI <sub>INST</sub>	4
Data to Clock Setup Time [measured at receiver]	T <sub>SETUP</sub> [RX]	-0.15		0.15	UI <sub>INST</sub>	5
		-0.2		0.2	UI <sub>INST</sub>	6
Data to Clock Hold Time [measured at receiver]	T <sub>HOLD</sub> [RX]	-0.15		0.15	UI <sub>INST</sub>	5
		-0.2		0.2	UI <sub>INST</sub>	6
20% -80% rise time and fall time	t <sub>R</sub> / t <sub>F</sub>	100			ps	9
				0.3	UI <sub>INST</sub>	7
				0.35	UI <sub>INST</sub>	8

Note:

1. This value corresponds to a minimum 80 MHz data rate.
2. The minimum UI shall not be violated for any single bit period, i.e., any DDR half cycle within a data burst.
3. Total silicon and package delay budget of 0.3\* UI<sub>INST</sub> when D-PHY is supporting maximum data rate = 1Gbps.
4. Total silicon and package delay budget of 0.4\* UI<sub>INST</sub> when D-PHY is supporting maximum data rate > 1Gbps.
5. Total setup and hold window for receiver of 0.3\* UI<sub>INST</sub> when D-PHY is supporting maximum data rate = 1Gbps.
6. Total setup and hold window for receiver of 0.4\* UI<sub>INST</sub> when D-PHY is supporting maximum data rate > 1Gbps.
7. Applicable when operating at HS bit rates ≤ 1 Gbps (UI ≥ 1 ns).
8. Applicable when operating at HS bit rates > 1 Gbps (UI < 1 ns).
9. Applicable for all HS bit rates. However, to avoid excessive radiation, bit rates ≤ 1 Gbps (UI ≥ 1 ns), should not use values below 150 ps.
10. For MIPI speed limitation:
  - [1] Per lane bandwidth is 1Gbps,
  - [2] Total Bit Rate: 4Gbps for 8-8-8; 3Gbps for 6-6-6; and 2.67Gbps for 5-6-5.

< HS Data Transmission >

High-Speed Data Transmission in Bursts

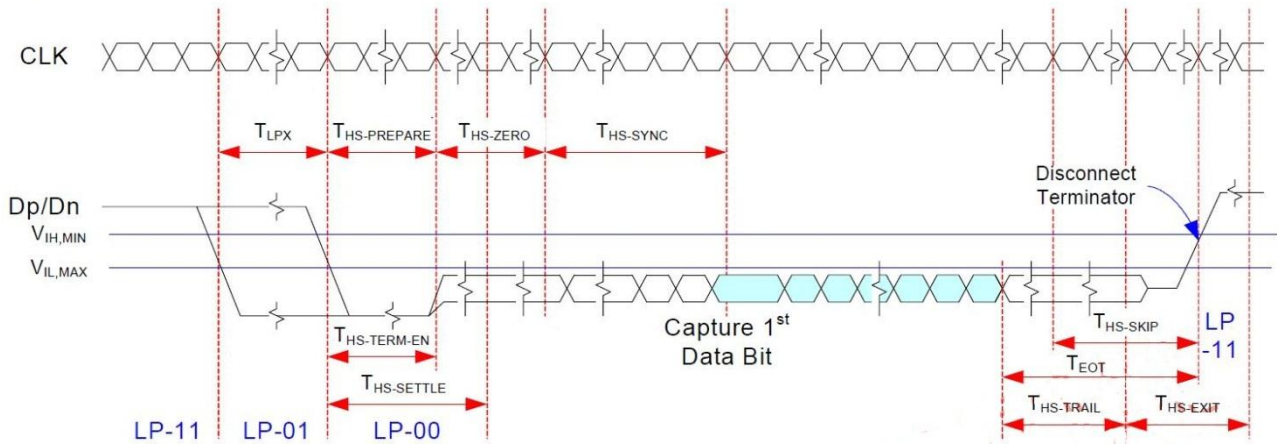

Fig.3

Table 8

Parameter	Symbol	Min	Typ	Max	Units
Time to drive LP-00 to prepare for HS transmission	$T_{HS-PREPARE}$	40+4UI		85+6UI	ns
Time from start of $T_{HS-TRAIL}$ or $T_{clk-TRAIL}$ period to start of LP-11 state	$T_{EOT}$			105+12UI	ns
Time to enable Data Lane receiver line termination measured from when Dn cross $V_{IL,MAX}$	$T_{HS-TERM-EN}$			35+4UI	ns
Time to drive flipped differential state after last payload data bit of a HS transmission burst	$T_{HS-TRAIL}$	60+4UI			ns
Time-out at RX to ignore transition period of EoT	$T_{HS-SKIP}$	40		55+4UI	ns
Time to drive LP-11 after HS burst	$T_{HS-EXIT}$	100			ns
Length of any Low-Power state period	$T_{LPX}$	50			ns
Sync sequence period	$T_{HS-SYNC}$		8UI		ns
Minimum lead HS-0 drive period before the Sync sequence	$T_{HS-ZERO}$	105+6UI			ns

Note:

- 1: The minimum value depends on the bit rate. Implementations should ensure proper operation for all the supported bit rates.
- 2: UI means Unit Interval, equal to one half HS the clock period on the Clock Lane.
- 3:  $T_{LPX}$  is an internal state machine timing reference. Externally measured values may differ slightly from the specified values due to asymmetrical rise and fall times.

### < Turnaround Procedure >

Turnaround Procedure

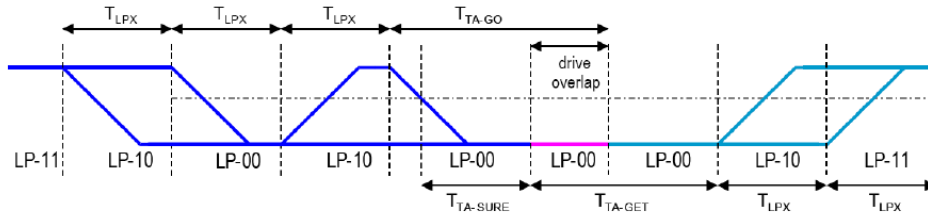

Parameter	Symbol	Min	Typ	Max	Units
Length of any Low-Power state period : Master side	$T_{LPX}$	50		75	ns
Length of any Low-Power state period : Slave side	$T_{LPX}$	50		75	ns
Ratio of $T_{LPX}(\text{MASTER})/T_{LPX}(\text{SLAVE})$ between Master and Slave side	Ratio $T_{LPX}$	2/3		3/2	
Time-out before new TX side start driving	$T_{TA-SURE}$	$T_{LPX}$		$2T_{LPX}$	ns
Time to drive LP-00 by new TX	$T_{TA-GET}$		$5T_{LPX}$		ns
Time to drive LP-00 after Turnaround Request	$T_{TA-GO}$		$4T_{LPX}$		ns

Fig.4

### <Switching the Clock Lane between Clock Transmission and Low-Power Mode >

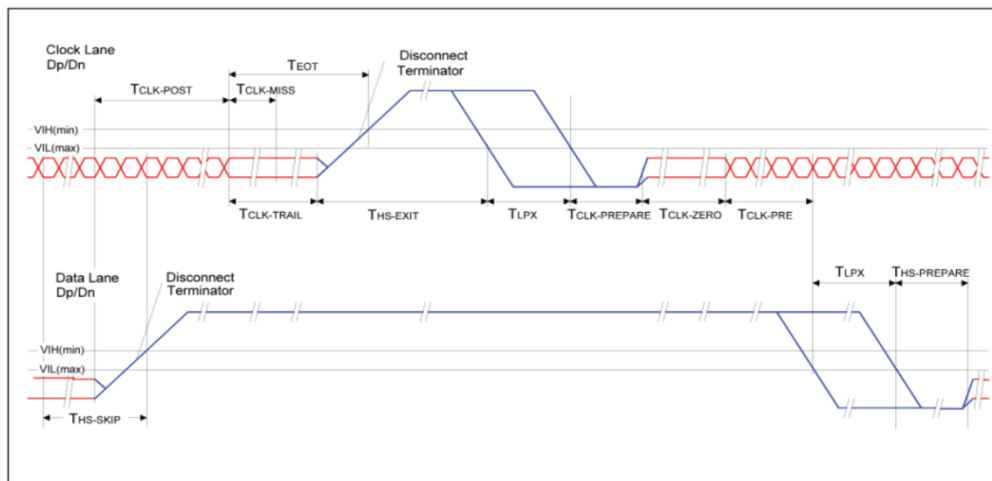

Fig.5

Table 9

Parameter	Symbol	Min	Typ	Max	Units
Time that the transmitter shall continue sending HS clock after the last associated Data Lane has transitioned to LP mode	TCLK-POST	60+128UI			ns
Detection time that the clock has stopped toggling	TCLK-MISS			60	ns
Time to drive LP-00 to prepare for HS clock transmission	TCLK-PREPARE	38		95	ns
Minimum lead HS-0 drive period before starting Clock	TCLK-PREPARE + TCLK-ZERO	300			ns
Time to enable Clock Lane receiver line termination measured from when Dn cross VIL, MAX	THS-TERM-EN			38	ns
Minimum time that the HS clock must be set prior to any associated date lane beginning the transmission from LP to HS mode	TCLK-PRE	8			UI
Time to drive HS differential state after last payload clock bit of a HS transmission burst	TCLK-TRAIL	60			ns

### (6-4) Reset Timing Characteristics

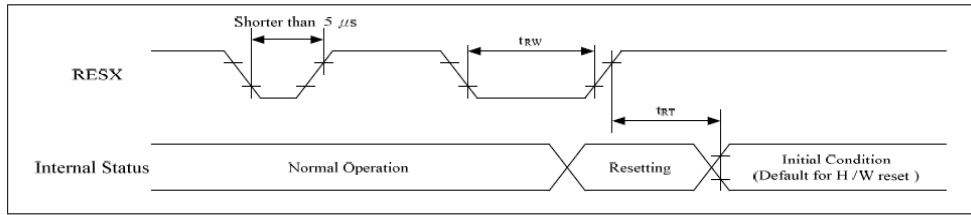

Fig.6

Table 10

Reset Timing Characteristics VSP=5.8V, VSN=-5.6V, VDDI=1.7~1.9V					
Signal	Symbol	Parameter	Min	Max	Unit
RESX	tRW	Reset pulse duration	10(Note)	-	us
	tRT	Reset cancel	-	10(Note)	ms
			-	120(Note)	ms

Note:

-The reset cancel also includes required time for loading ID bytes, VCOM setting and other settings from EEPROM (or similar device) to registers.

This loading is done every time when there is HW reset cancel time (tRT) within 10 ms after a rising edge of RESX.

-Spike due to an electrostatic discharge on RESX line does not cause irregular system reset according to the table below:

RESX	Pulse Action
Shorter than 5us	Reset Rejected
Longer than 9us	Reset
Between 5us and 9us	Reset Starts

Fig.7

-During the Resetting period, the display will be blanked(The display is entering blanking sequence, which maximum time is 120 ms, when Reset starts at Sleep-Out status. The display remains the blank state in Sleep-In mode). Then return to Default condition for Hardware Reset.

-Spike Rejection also applies during a valid reset pulse as shown below:

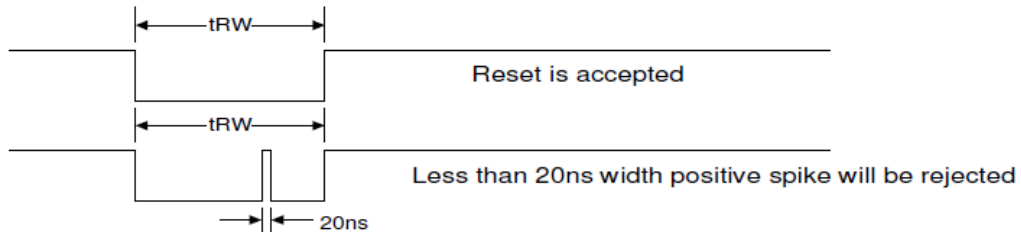

Fig.8

-When Reset applied during Sleep-In Mode.

-When Reset applied during Sleep-Out Mode.

-It is necessary to wait 10ms after releasing RESX before sending commands. Also Sleep Out command cannot be sent for 120 ms.

(6-5). Vertical Timing Characteristics

Table 11

Ta=+25°C

Parameter	Symbol	MIN.	TYP.	MAX.	Unit	Remarks
Refresh frame rate operation range	Rfror	57	60	63	Hz	

(6-6) LED backlight

At main panel the back light uses 12pcs edge light type white LED.

Table 12

Parameter	Conditions	Symbol	Min.	Typ.	Max.	Unit	Remark
Forward current	Ta=25 °C	$I_{LED}$	-	20	-	mA	
Forward Voltage	Ta=25 °C	$V_{LED}$	-	2.9	3.1	V	
Number of LED components	12 pcs LED (6 pcs serial X 2 parallel)						

\*Please consider Allowable Forward Current on used temperature

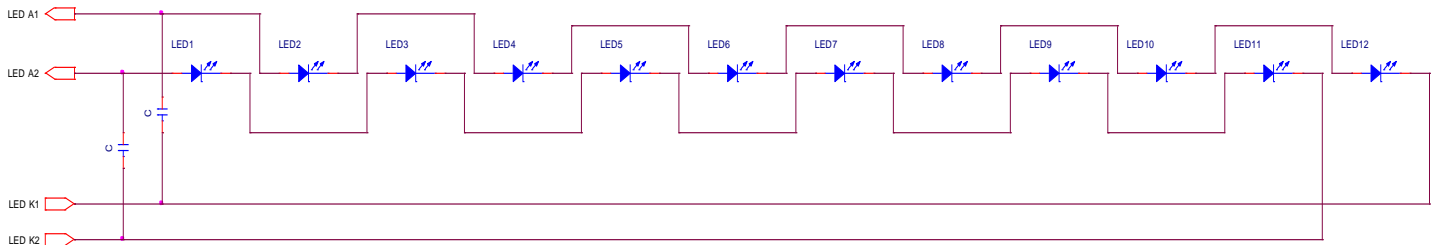

Fig.9 Schematics drawing of lighting

(6-7) Interface signals

Table 13

Pin No.	Symbol	I/O	Description	Remarks
1	ID (GND)	-	ID code	
2	LED_K1	I	LED Cathode	
3	LED_K2	I	LED Cathode	
4	NC	-	No connect	
5	LED_A2	I	LED Anode	
6	LED_A1	I	LED Anode	
7	NC	-	No connect	
8	GND	-	Ground level	
9	VGHSSI	-	Ground level	
10	D3N	I	MIPI data3 negative signal line	
11	GND	-	Ground level	
12	D3P	I	MIPI data3 positive signal line	
13	VGHSSI	-	Ground level	
14	D0N	I/O	MIPI data0 negative signal line	
15	GND	-	Ground level	
16	D0P	I/O	MIPI data0 positive signal line	
17	VGHSSI	-	Ground level	
18	CLKN	I	MIPI clock signal line	
19	GND	-	Ground level	
20	CLKP	I	MIPI clock signal line	
21	VGHSSI	-	Ground level	
22	D1N	I	MIPI data1 negative signal line	
23	GND	-	Ground level	
24	D1P	I	MIPI data1 positive signal line	
25	VGHSSI	-	Ground level	
26	D2N	I	MIPI data2 negative signal line	
27	GND	-	Ground level	
28	D2P	I	MIPI data2 positive signal line	
29	VGHSSI	-	Ground level	
30	GND	-	Ground level	
31	TE	O	TE signal output from driver IC	
32	GND	-	Ground level	
33	LEDPWM	O	Backlight LED driver PWM	
34	VSP	I	Analog Power Supply	
35	GND	I	Ground level	
36	VDDI	I	1.8V Digital Power Supply	
37	RES	I	Reset Pin	
38	VSN	I	Analog Power Supply	
39	NC	-	No connect	

Fitting connector(User side): Hirose(FH26-39S-03SHW)

About Recommendation of the outside circuit , refer to Fig.10 below.



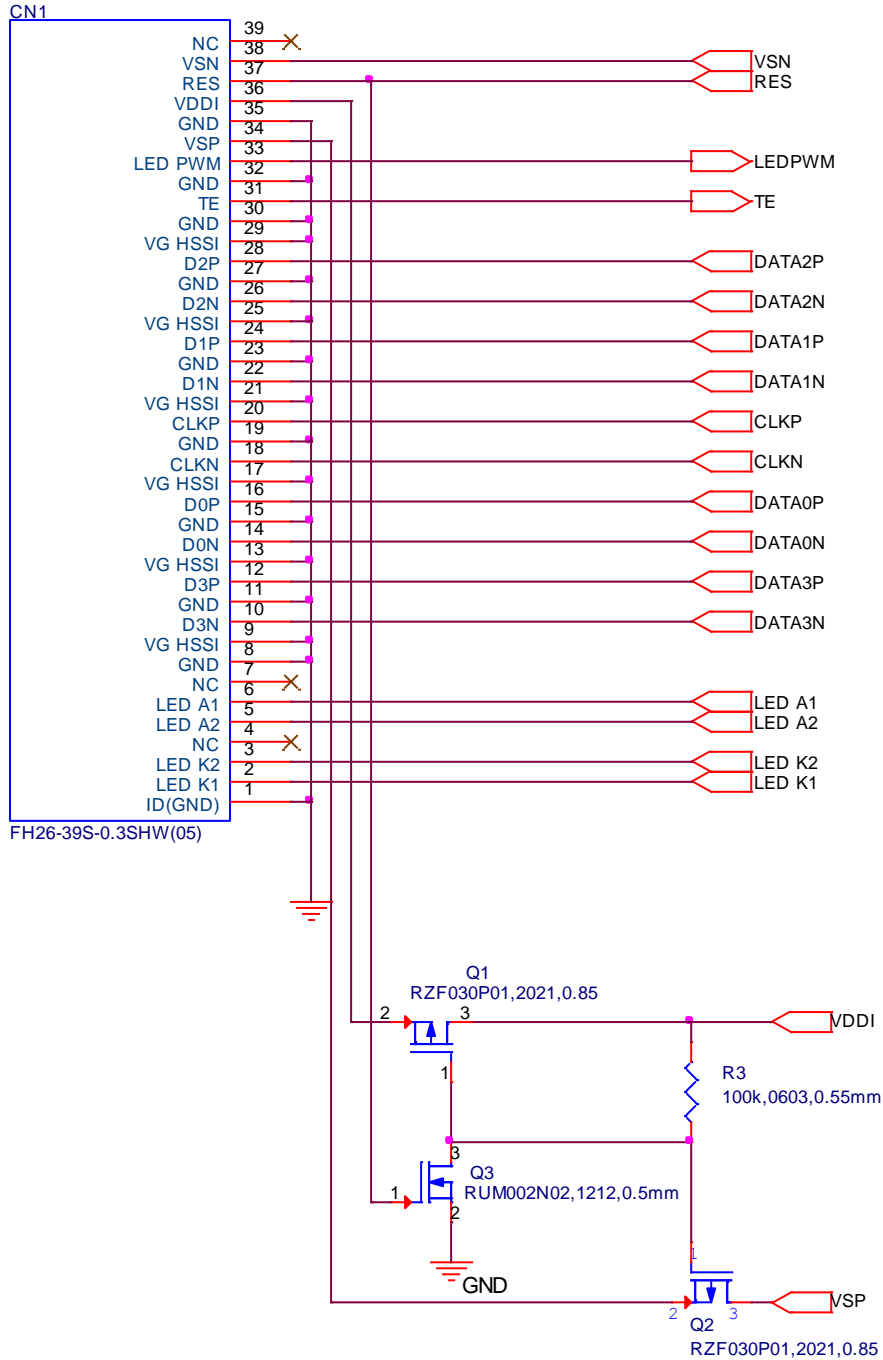

Fig.10 Recommendation of the outside circuit

(6-8) General Timing Diagram

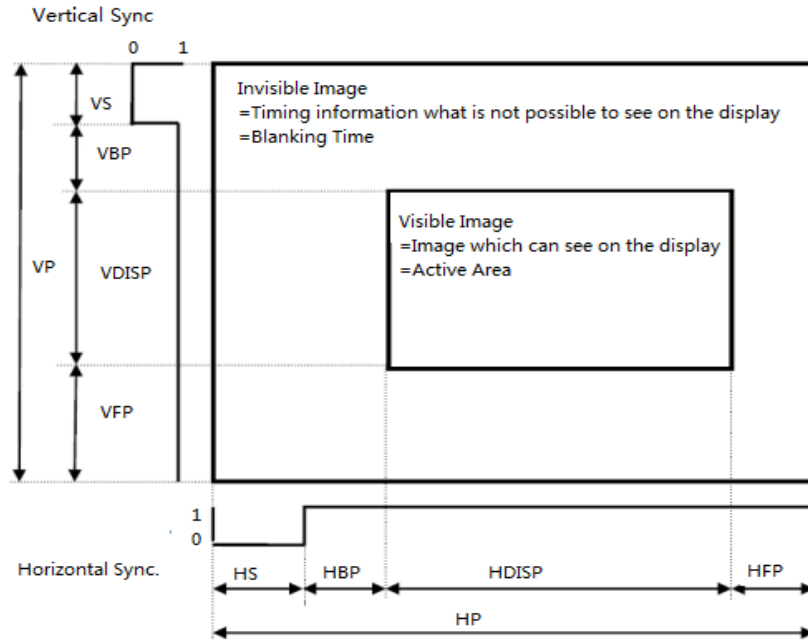

Fig.11

(6-9) Vertical Timing

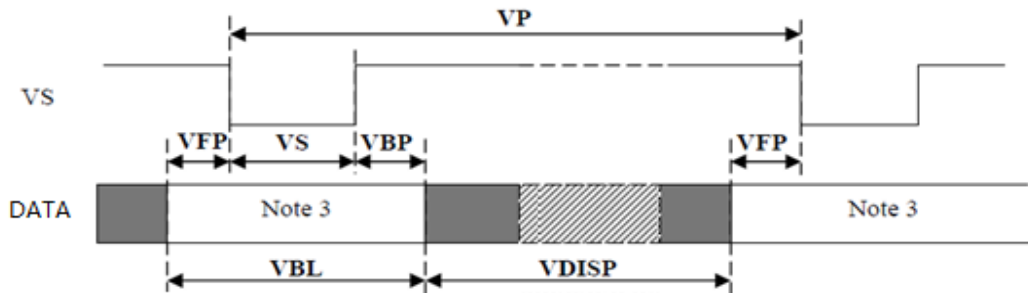

Fig.12

Table 14 Vertical Timing

Item	Symbol	Conditions	Min.	Typ.	Max.	Unit
Verticle cycle	VPT	VDISP+VBLK		1942	-	Line
Verticle low pulse width	VS		-	2	-	Line
Vertical front porch	VFP		-	14	-	Line
Vertical back porch	VBP		-	6	-	Line
Vertical data start point		VS+VBP	-	8	-	Line
Vertical blanking period	VBLK	VS+VBP+VFP	-	22	-	Line
Vertical active area		VDISP	-	1920	-	Line
Vertical Refresh Rate	VRR		58.40	60.00	62.00	Hz

Ta = -20 °C ~ +60°C, VSP=5.8V, VSN=-5.6V, VDDI=1.8V, GND = 0 V

## (6-10) Horizontal Timing

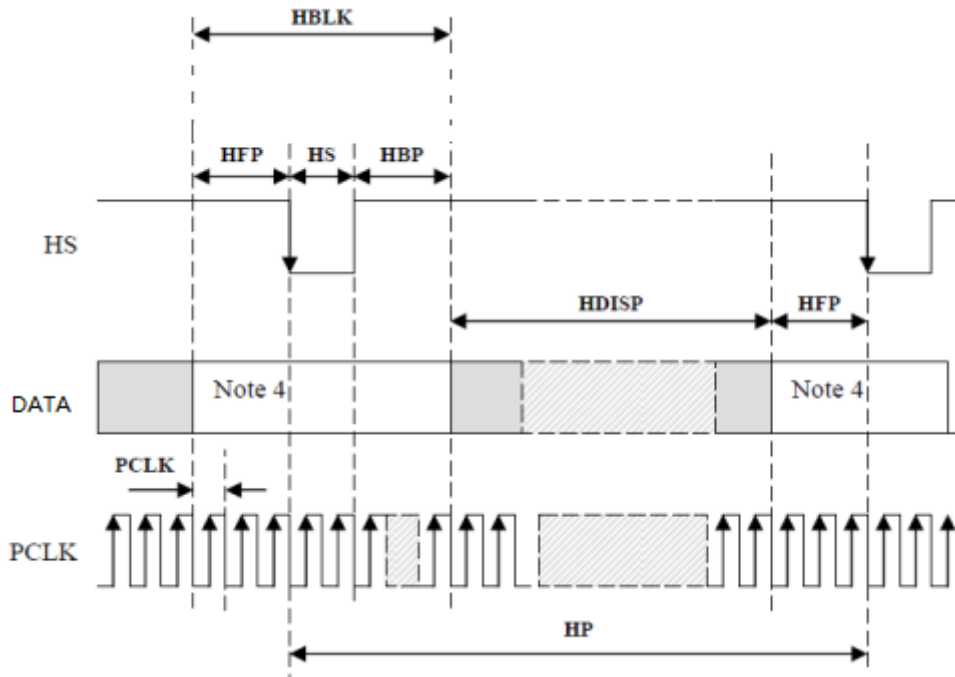

Fig.13

Table 15 Horizontal Timing

Item	Symbol	Conditions	Min.	Typ.	Max.	Unit
HS cycle	HPT	HDISP+HBLK	-	1176	-	PCLK
HS low Pulse width	HS		-	8	-	PCLK
Horizontal back porch	HBP		-	16	-	PCLK
Horizontal front porch	HFP		-	72	-	PCLK
Horizontal data start point		HS+HBP	-	24	-	PCLK
Horizontal blanking period	HBLK	HS+HBP+HFP	-	96	-	PCLK
Horizontal active area	HDISP		-	1080	-	PCLK
1 Horizontal Timing			8.30	8.56	8.82	us
Pixel clock frequency	PCLK		-	137.38	-	MHz
MIPI Speed	-	-	840	860	900	Mbps/lane

Ta = -20 °C ~ +60°C, VSP=5.8V, VSN=-5.6V, VDDI=1.8V, GND = 0 V

(6-11) Schematic of LCD module system

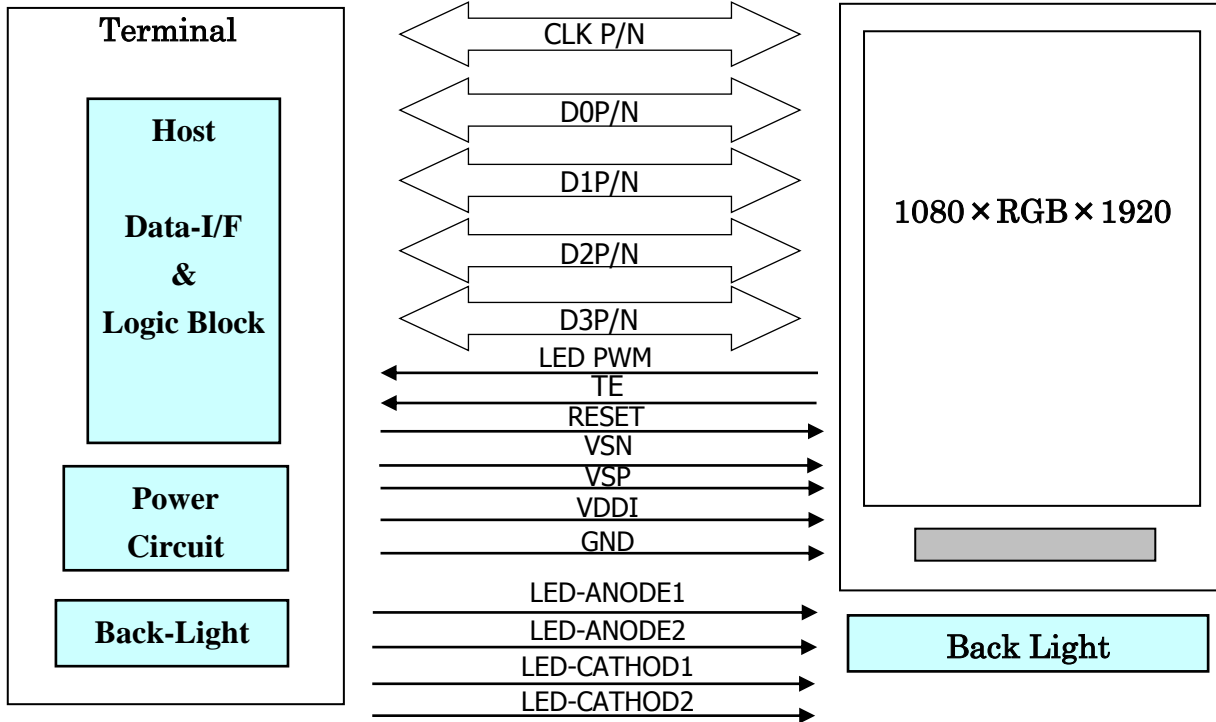

Fig.14 Schematic of LCD module system

## 7. Initial Sequence

(7-1) Power ON sequence

Item	ADDRESS (Hex)	PARAMETER (Hex)	Description
<b>RESX=low</b>			
<b>Wait more than 450ms</b>			For VDDI discharge, and POR success
<b>Power Supply VDDI(Typ1.8V)</b>			
<b>Wait more than 10ms</b>			
<b>XRES=high</b>			
<b>Wait more than 80ms</b>			For abnormal power-on success.
<b>XRES=low</b>			
<b>XRES Low pulse width needs more than 1ms</b>			For abnormal power-on success.
<b>XRES=high</b>			
<b>Wait min 1ms</b>			
<b>Power Supply VSP(Typ+5.8V)</b>			For VSP abnormal cut-off circuit
<b>Wait min 1ms</b>			
<b>Power Supply VSN(Typ-5.6V)</b>			For VSN abnormal cut-off circuit
<b>Wait more than 10ms</b>			
CMD page select	FF	00	
NON-RELOAD CMD	FB	01	
<b>Wait more than 20ms</b>			
CMD page select	FF	00	
	D3	08	VBP=8 VFP=14
	D4	0E	
Sleep out	11		
<b>wait for more than 100ms</b>			
<b>DSI Video Mode transfer start</b>			
Display on	29		
<b>wait for more than 40ms</b>			
Write Display Brightness	51	00	FFh: LED light=100%
		FF	
Write Control Display	53	2C	LED(PWM) ON
Write Power Save	55	0x	CABC OFF=00h, CABC ON=02h
<b>Turn on B/L</b>			

(7-2) Power OFF sequence

Item	ADDRESS (Hex)	PARAMETER (Hex)	Description
Write Control Display	53	00	Turn off B/L
wait for more than 0ms			
Display OFF	28		
Sleep in	10		
wait for more than 100ms (=6Frames)			
DSI Video Mode transfer stop			
CMD page select	FF	00	
Wait more than 0ms			
VSN OFF			
Wait min 1ms			
VSP OFF			
XRES=low			
Wait more than 0ms			
VDDI(Typ1.8V) OFF			

## 8. Optical Characteristics

Table 16

Optical Characteristics							
Parameter	symbol	condition	MIN	TYP	MAX	unit	Remark
Brightness	Br	$\theta=0^\circ$	340	450	-	cd/m <sup>2</sup>	Note1,2
Contrast	Co	$\theta=0^\circ$	700	1000	-		Note1,3
Viewing Angle	$\theta_{11}$	CR > 10	-	80	-	deg	Note1
	$\theta_{12}$		-	80	-		
	$\theta_{21}$		-	80	-		
	$\theta_{22}$		-	80	-		
Response Time	( $\tau_r + \tau_d$ )	$\theta=0^\circ$	-	-	35	ms	Note1,4
White Chromaticity	x	$\theta=0^\circ$	0.27	0.3	0.33	-	Note 1, 7
	y		0.28	0.31	0.34		
Red Chromaticity	x	$\theta=0^\circ$	0.61	0.64	0.67	-	Note 1, 7
	y		0.31	0.34	0.37		
Green Chromaticity	x	$\theta=0^\circ$	0.27	0.30	0.33	-	Note 1, 7
	y		0.58	0.61	0.64		
Blue Chromaticity	x	$\theta=0^\circ$	0.12	0.15	0.18	-	Note 1, 7
	y		0.03	0.06	0.09		
Uniformity	-	$\theta=0^\circ$	70	80	-	%	Note.5
NTSC ratio	-	$\theta=0^\circ$	60	70	-	%	Note.1
Flicker	F	$\theta=0^\circ$	-	-	10	%	Note.6

VSP=5.8V, VSN=-5.6V, VDDI=1.8V, ILED=20mA, Ta = 25°C

Note 1) Definition of range of visual angle

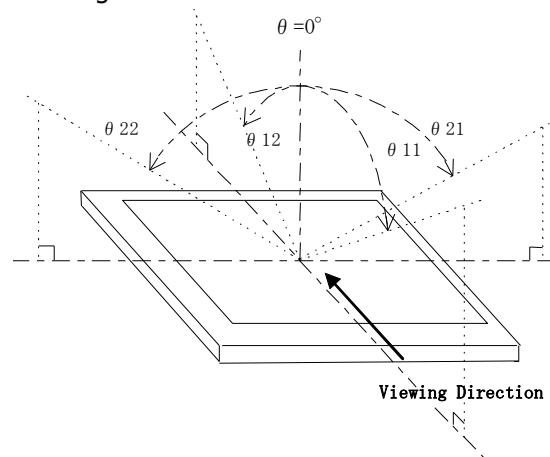

Fig.15 Definition of viewing angle

Note 2) Brightness is measured as shown in Fig.16, and is defined as the brightness of all pixels "White" at the center of display area on optimum contrast.

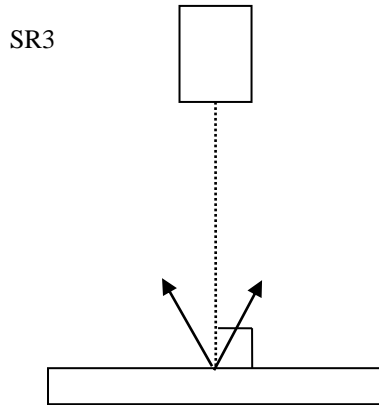

Fig.16 Optical characteristics Test Method (Brightness)

Note 3) Contrast ratio is defined as follows:

$$Co = \frac{\text{Luminance}(\text{brightness})\text{allpixels} \text{"White"}}{\text{Luminance}(\text{brightness})\text{allpixels} \text{"Black"}}$$

Note 4) Response time is defined as follows:

Definition of response time: The response time is defined as the following figure and shall be measured by switching the input signal for "black" and "white"

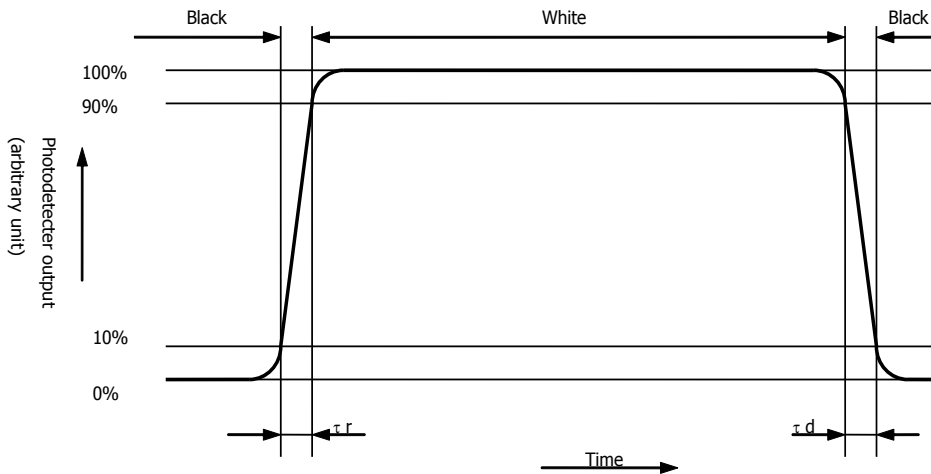

Fig.17 Response time

Note 5) Uniformity is defined as follows:

$$\text{Uniformity} = \frac{\text{Minimum Luminance}(\text{brightness})}{\text{Maximum Luminance}(\text{brightness})} \times 100(\%)$$



The brightness should be measured on the 9-points as shown in the following figure.

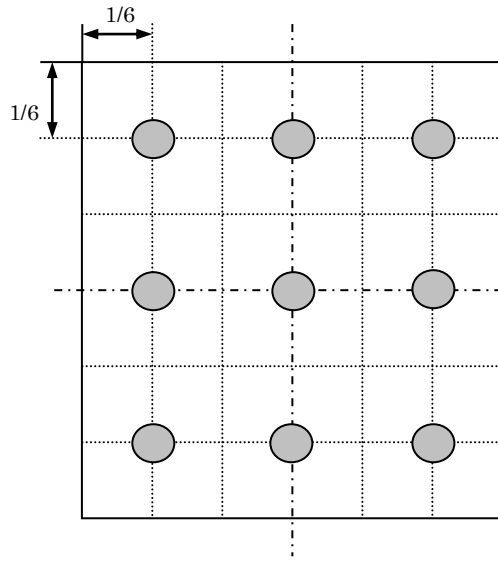
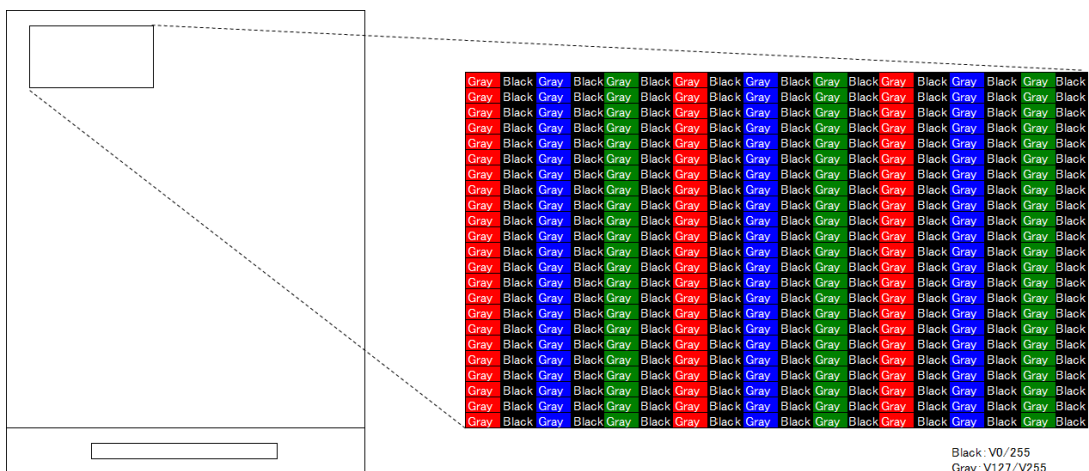

Fig.18 Measuring Point

Note 6) Flicker is defined as follows:

- Measuring systems: YOKOGAWA 3298\_01 + 3298\_11
- Temperature = 25°C(±3°C), Frame Frequency = 60Hz, LED back-light: ON, Environment brightness < 150 lx
- Measurement point is panel center.
- Conversion of Flicker ratio : Flicker[%] = ACrms/DC × 100
- Measured sample : New sample before a long term aging.
- Flicker ratio is very sensitive to measuring condition.
- Measuring pattern Please refer to figure below.



Black : V0 / 255  
Gray : V127 / V255

Fig.19 Measuring pattern

(Note 7) This shall be measured at center of the screen.

## 9. Reliability

Table.17

No.	Test	Condition	Judgment criteria
1	Temperature Cycling	Ta = -30 ° C (30min) ~ 70 ° C(30min), 32cycle	Per table in below
2	Humidity Operation	Ta = +40°C 95%RH 120h	Per table in below
3	High Temp. Storage	Ta= 70°C 120h	Per table in below
4	Low Temp. Storage	Ta=-30°C 120h	Per table in below
6	High Temp. Operation	Ta= 60°C 120h	Per table in below
7	Low Temp. Operation	Ta=-20°C 120h	Per table in below
8	ESD	Discharge resistance: 0 Ω Discharge capacitor: 200 pF Discharge voltage: ±200 V Max Discharge 1 time to each input line ※ "GND" of display module is connected GND of test system ground.	Per table in below

## 10. Packaging specifications

### (10-1) Details of packaging

- 1) Packaging materials: Table 19
- 2) Packaging style : Fig. 20、 21

### (10-2) Reliability

#### 1) Vibration test

Table.18

Item	Test			
Frequency	5 Hz to 50 Hz (3 minutes cycle)			
Direction	Up-Down, Left-Right, Front-Back (3 directions)			
Period	Up-Down	Left-Right	Front-Back	Total
	60min	15min	15min	90min

The frequency should start at 5 Hz and vary continuously.

Total amplitude	20mm	0.2mm	20mm	0.2mm	
Frequency	5 Hz	50 Hz	5 Hz	50 Hz	(For 9.8m/s <sup>2</sup> )
	○	○	○		
	← 3 minutes →				

#### 2) Drop test

Drop height: 750mm  
Number of drop: 10 times (Drop sequence: 1 corner, 3 edges, 6 faces)

### (10-3) Packaging quantities

240 modules per master carton

### (10-4) Packaging weight

About 12KG

### (10-5) Packaging outline dimensions

530 mm×365 mm×279mm (H)

#### (Packaging materials)

Table.19

	Parts name	CRITERION(after test)
1	Master carton	Corrugate card board
2	Inside sleeve	Corrugate card board
3	Outside sleeve	Corrugate card board
4	Tray for packaging	Polystyrene with anti-static treatment +anti-static polystyrene
5	Aluminum bag	PET/ AL /PA/PE with anti-static treatment
6	OPP tape	Polypropylene
7	Bar code label	anti-static polystyrene

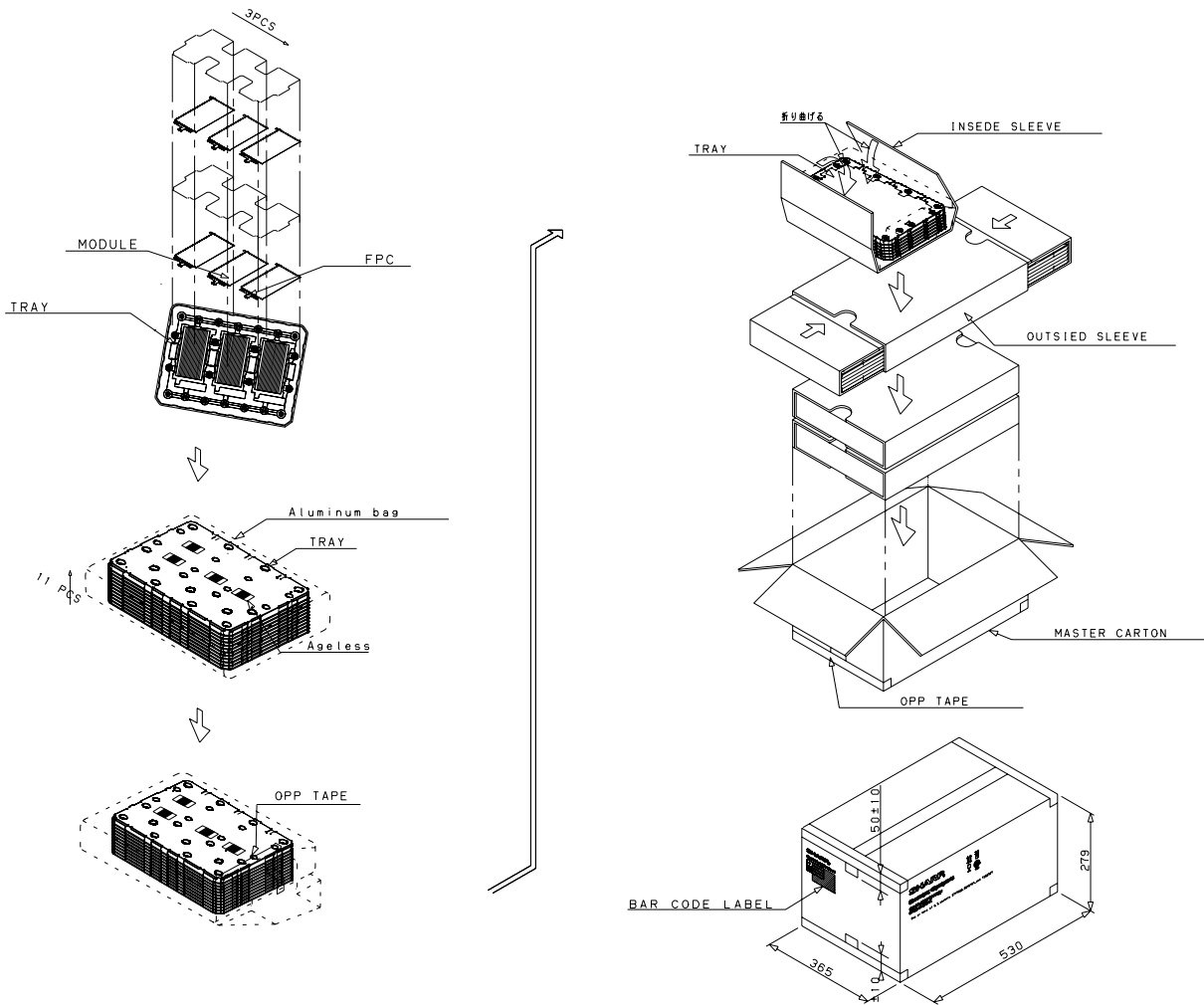

**Fig.20 Packaging style (Tray for packaging)**



**Fig.21 Packaging style (Master carton for packaging)**

## **11. Serial Number Label identification**

Numbering is specified as follows.

LQ055T3SX02(G) 4 G 0000001 A Q

①            ②③    ④    ⑤⑥

①LCD Module Code

②product year ( lower 1 digits )

4: 2014

5: 2015

③product month

1: January

2: February

3: March

:

9: September

X: October

Y: November

Z: December

④serial number

0000001 ~ 9999999

⑤Version number

⑥factory code

## 12. Outline dimensions

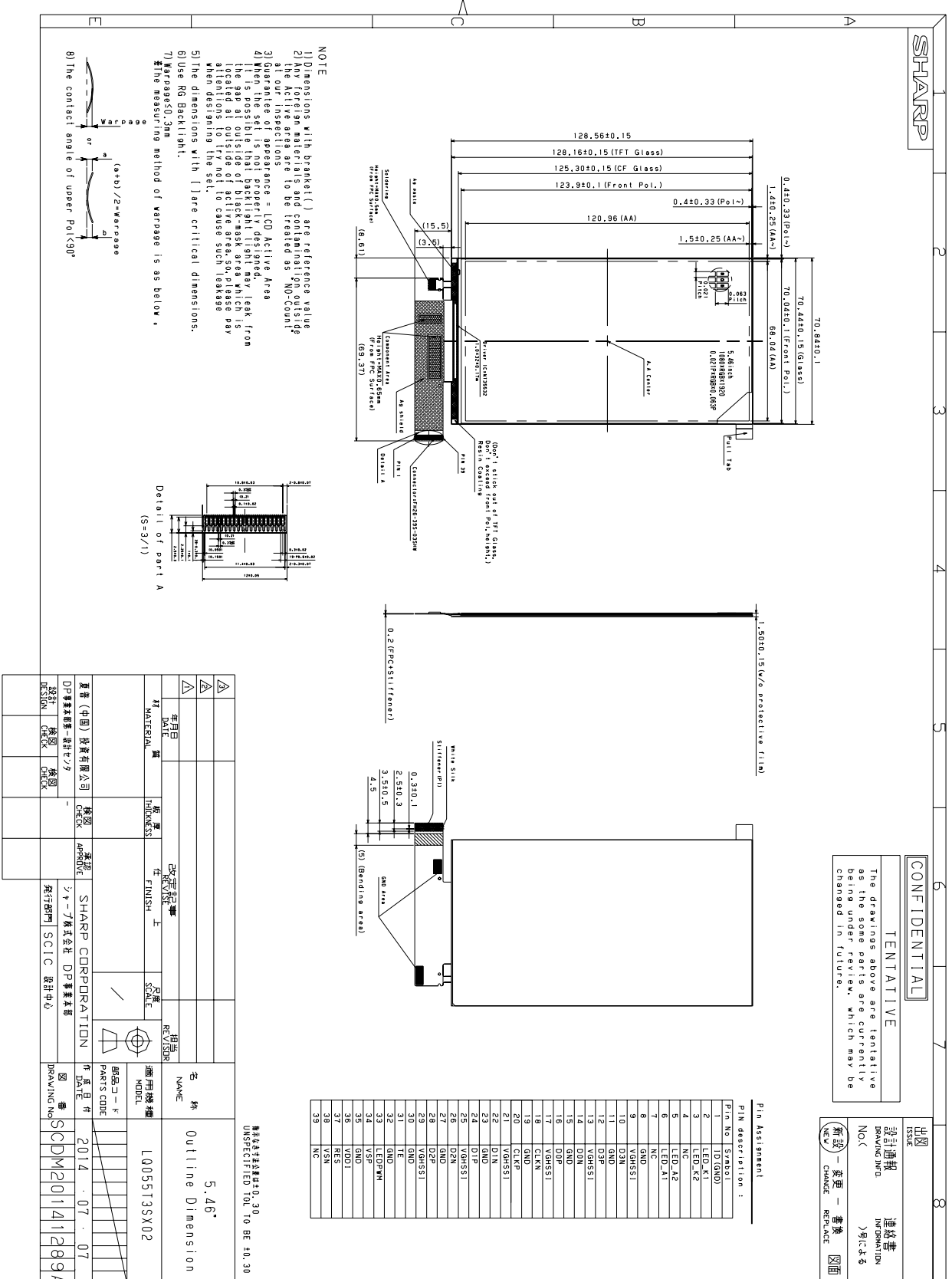

Fig. 22 Outline dimensions