

HF series

Hall effect joysticks

Distinctive features and specifications



- Connectorized housing
- Voltage regulator, 24V supply option
- Shallow mounting depth <1.00"
- USB 1.1 HID interface option
- 1, 2 and 3 axis configurations

MECHANICAL (FOR X, Y AXIS)
<ul style="list-style-type: none"> • Break Out Force: 1.3N (0.3lbf) • Operating Force: 2.8N (0.63lbf) • Maximum Applied Force: 200N (45.00lbf) • Mechanical Angle of Movement: 36° (18° from center) • Expected Life: 5 million • Material: Glass filled nylon • Package Size: 5.75" x 4.50" x 3.25" • Lever Action: Single spring, omnidirectional

ENVIRONMENTAL
<ul style="list-style-type: none"> • Operating Temperature: -40°C to 70°C (-40°F to 158°F) • Storage Temperature: -40°C to 70°C (-40°F to 158°F) • Sealing (IP): Up to IP68* • EMC Immunity Level (V/M): EN61000-4-3 • EMC Emissions Level: EN61000-6-3:2001 • ESD: EN61000-4-2

MECHANICAL (FOR Z AXIS)
<ul style="list-style-type: none"> • Break Out Torque: 0.09N·m (0.80lbf-in) • Operating Torque: 0.121N·m(1.07lbf-in) • Maximum Allowable Torque: 2.50N·m(22.13lbf-in) • Hand Mechanical Angle: 60° (30° from center) • Handle Action: Spring centering, rotational • Expected Life: 5 million

ELECTRICAL
<ul style="list-style-type: none"> • Sensor: Hall effect • Resolution: 1.22mV • Supply Voltage Operating: 5VDC±0.01VDC • Reverse Polarity Max: -10VDC • Overvoltage Max: 20VDC • Output Voltage: See options • Output Impedance: 2Ω • Return to Center Voltage (No Load): ±200mV • Error signal: 1.0%

NOTES:

- All values are nominal.
- Exact specifications may be subject to configuration. Contact Technical Support for the performance of your specific configuration.
- * Excludes some handle options.



HF series

Hall effect joysticks

Overview

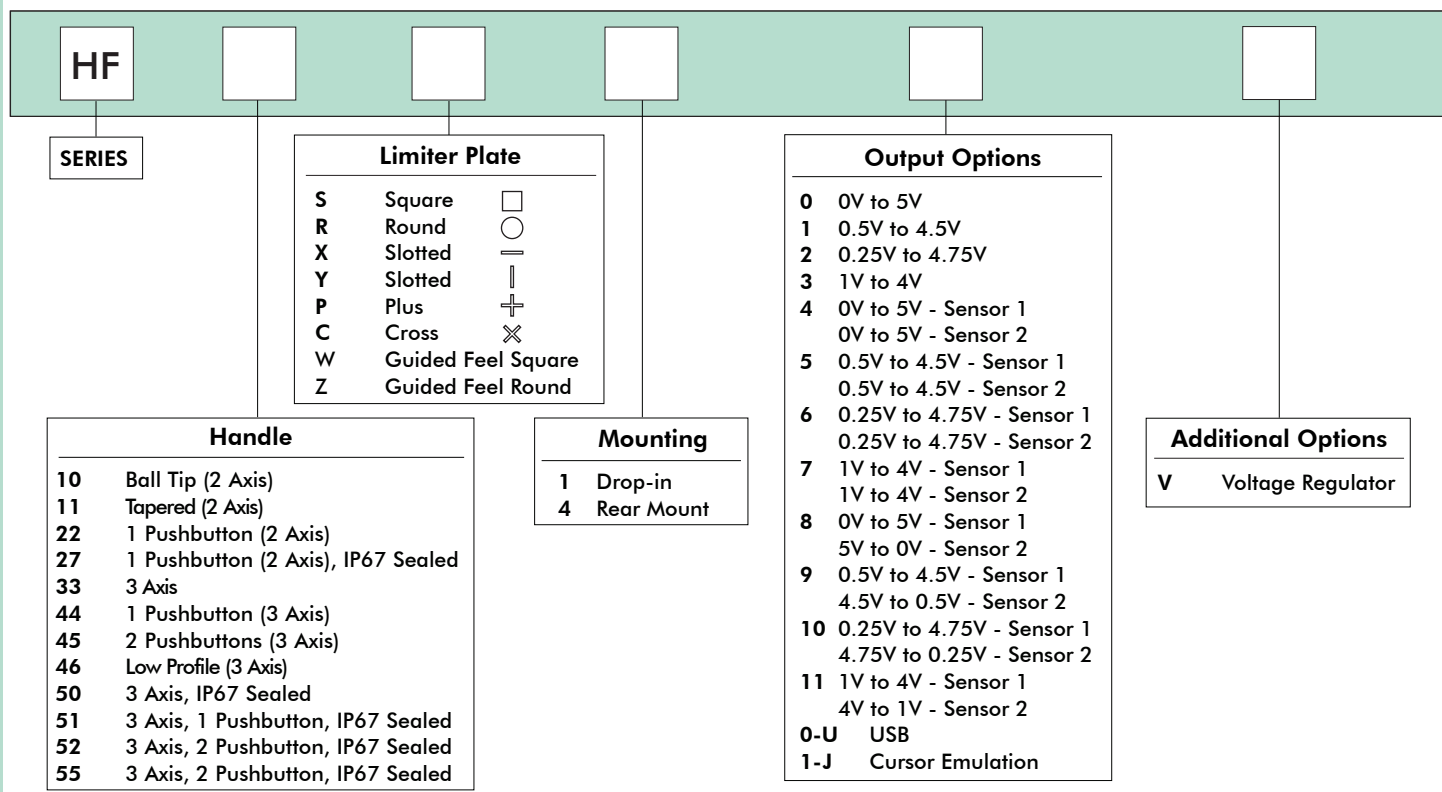

NOTES

- The HF Series joysticks are supplied with a Hirose DF11-12DP-2DS9(24) connector (male receptacle). (Fig 1)
Cable not included. Please request at order entry. Cable connector (female socket) is Hirose DF11-12DS-2C. (Fig 2)
Connector specifications: 12 position 2mm pitch dual row (2x6) pin header.

Wire Color	Description
Black	Ground
Red	Power
Blue/White	X-Axis (Dual Output)
Blue	X-Axis
Yellow/Black	Y-Axis (Dual Output)
Yellow	Y-Axis
Green/Black	Z-Axis (Dual Output)
Green	Z-Axis
Orange	Button 1
White	Button Common
Violet	Button 2



Up to IP68 available.



Mounting accessories. Standard hardware includes: gasket, clamping ring, and four #4-40x3/4 Phil Ph MS SS screws.



HF series

Hall effect joysticks

Overview

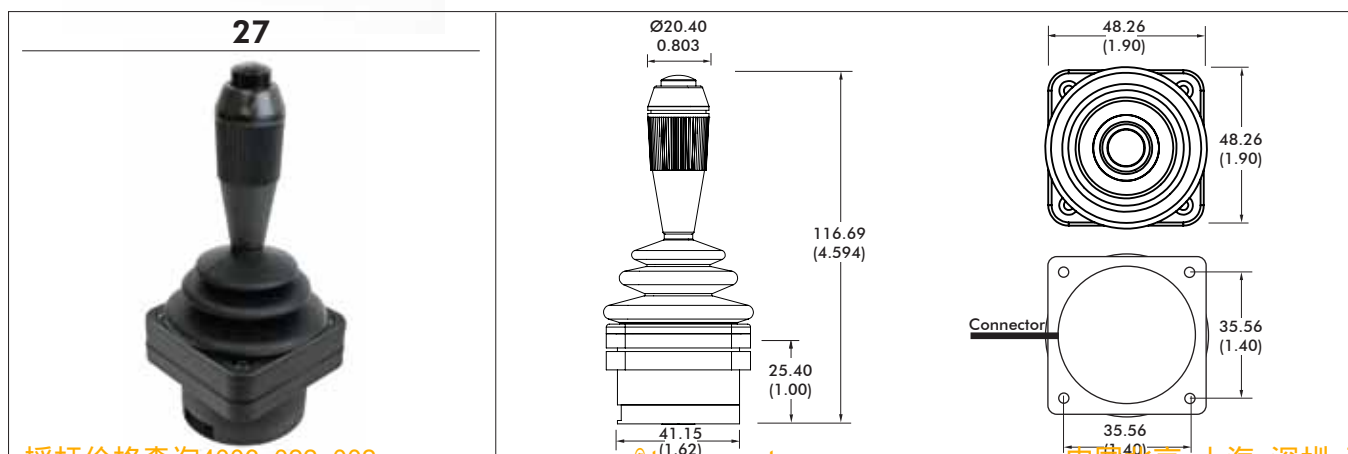
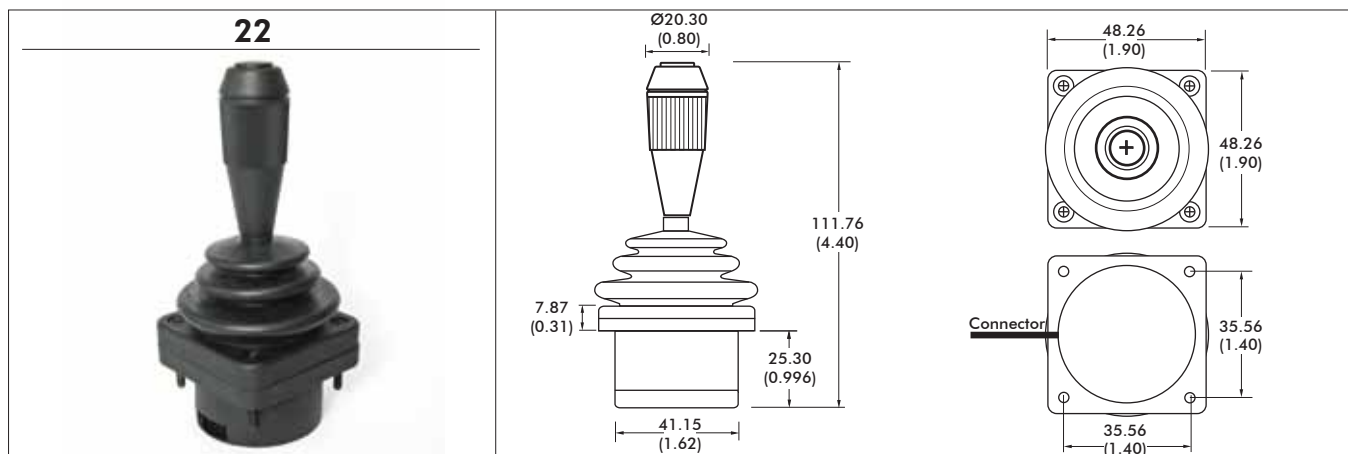
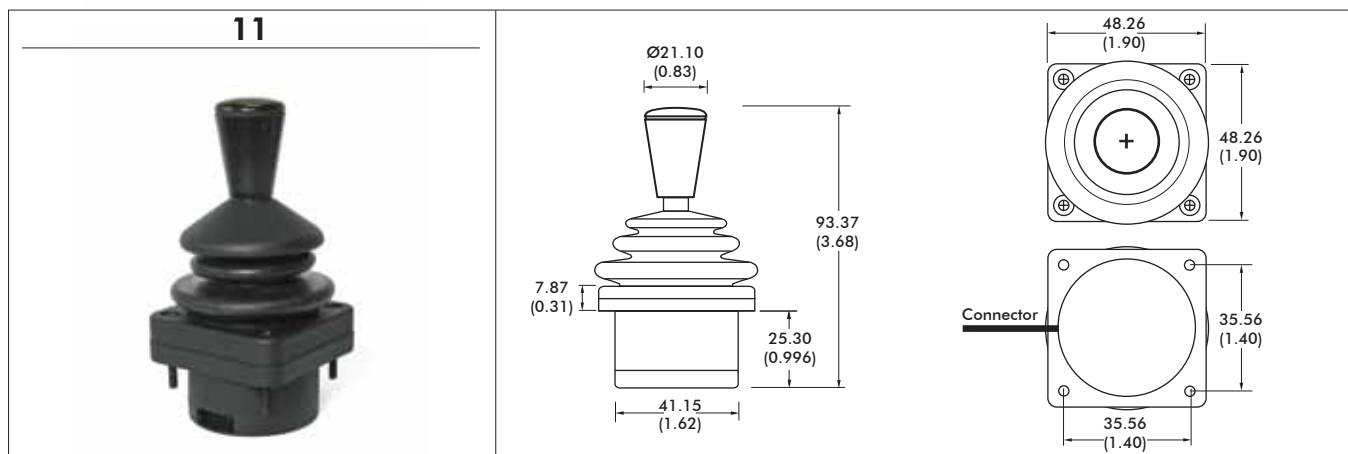
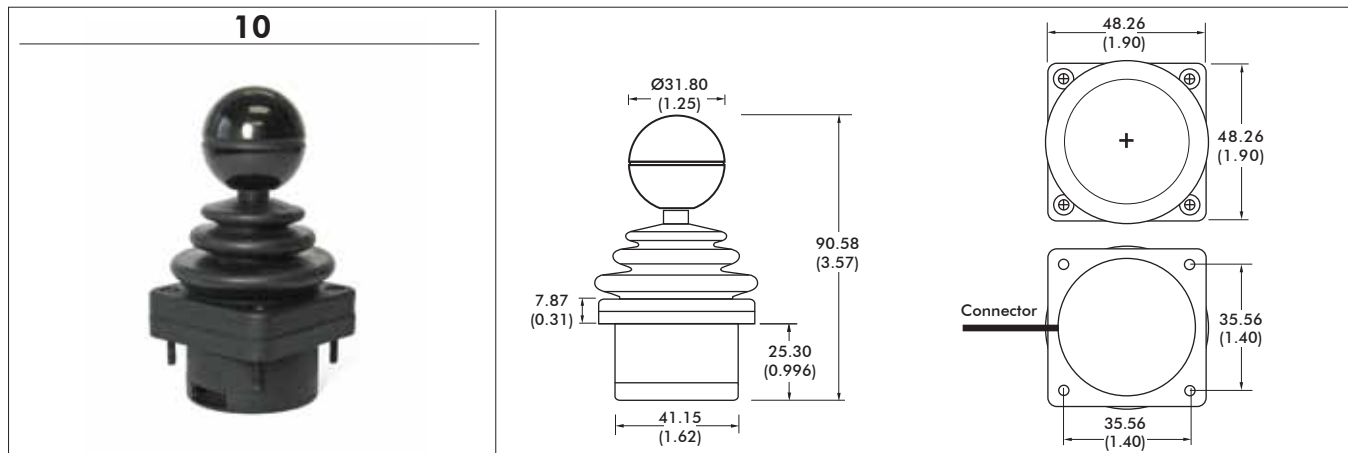

HF series

Hall effect joysticks

Overview

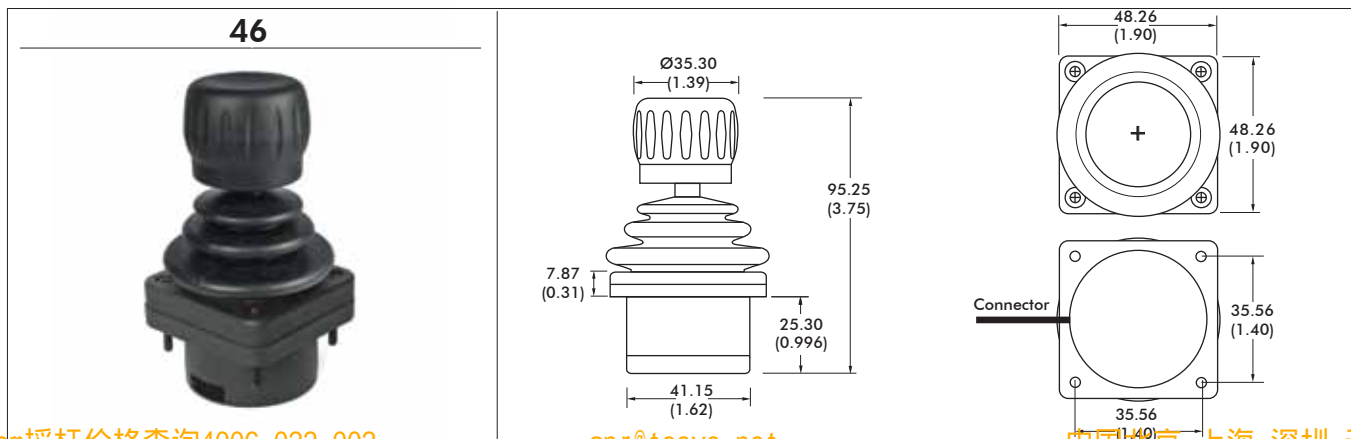
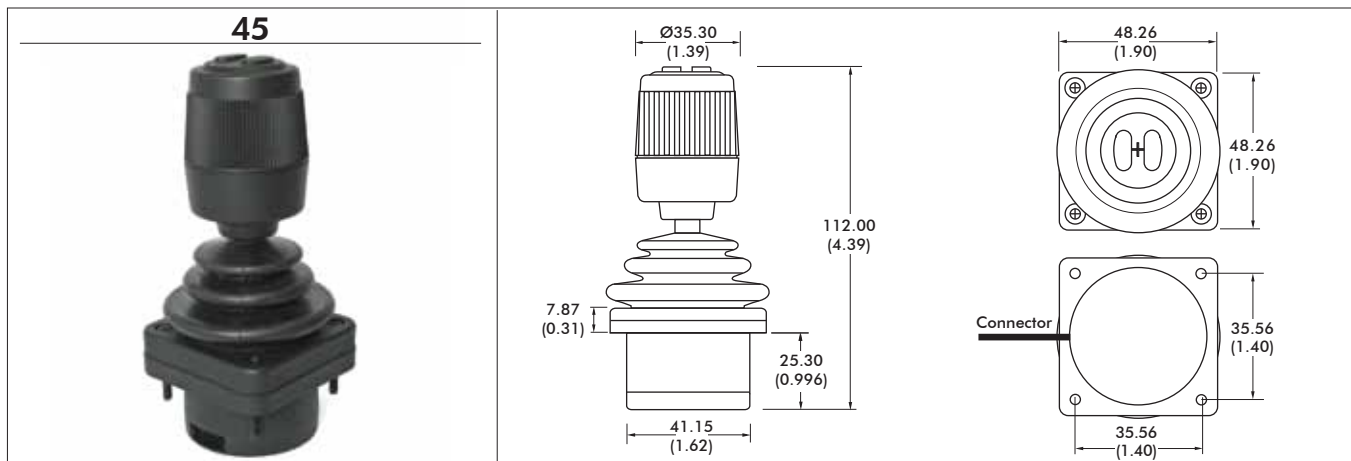
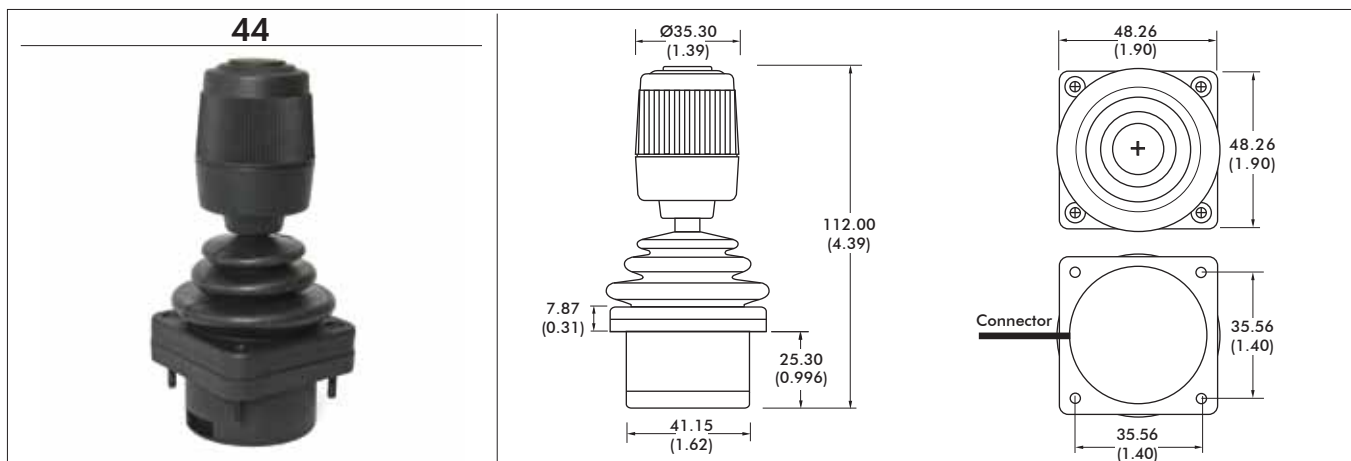
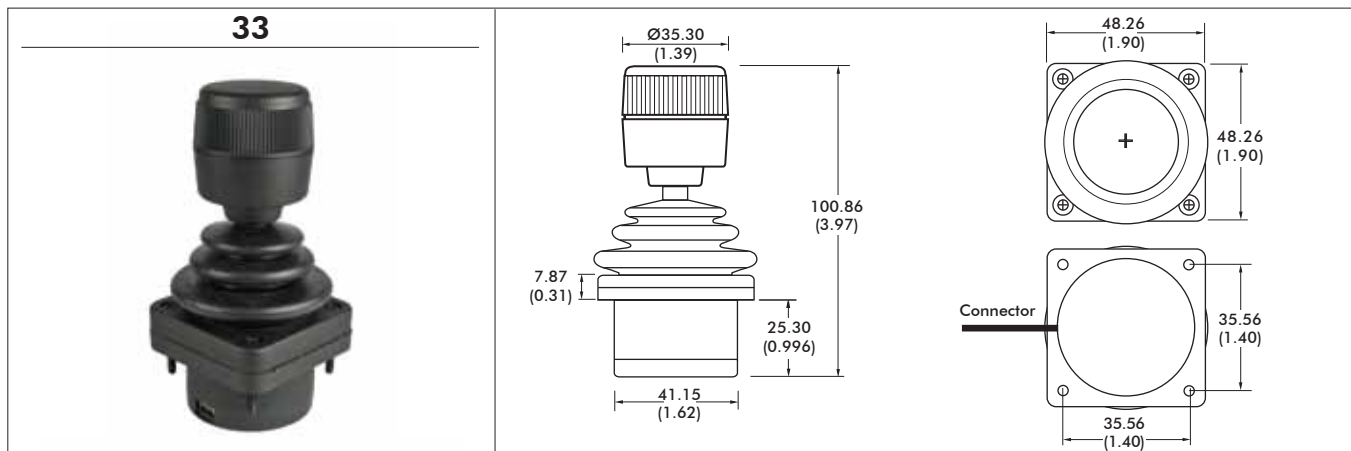

HF series

Hall effect joysticks

Overview

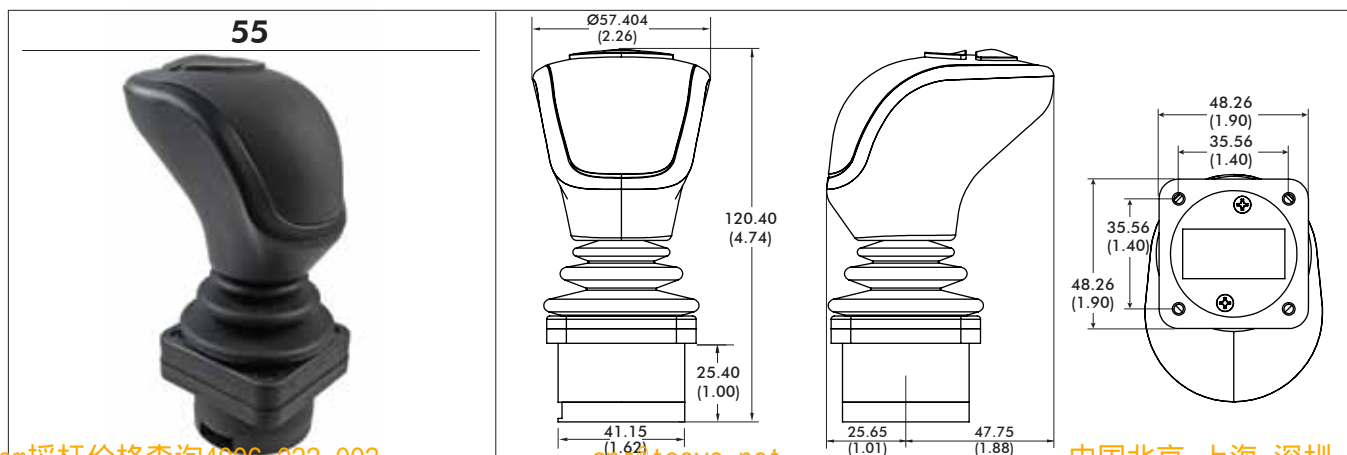
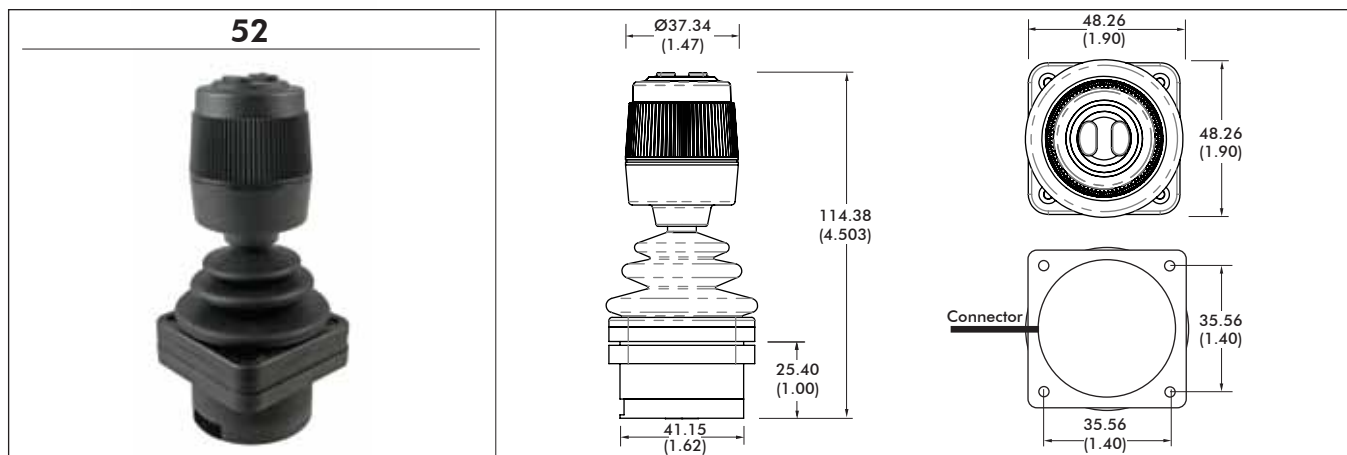
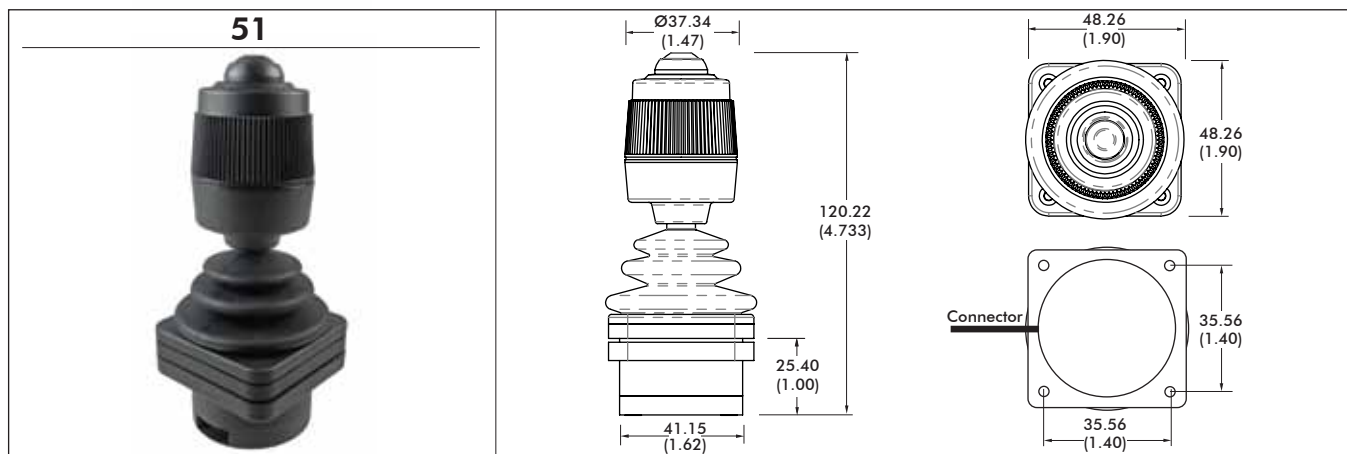
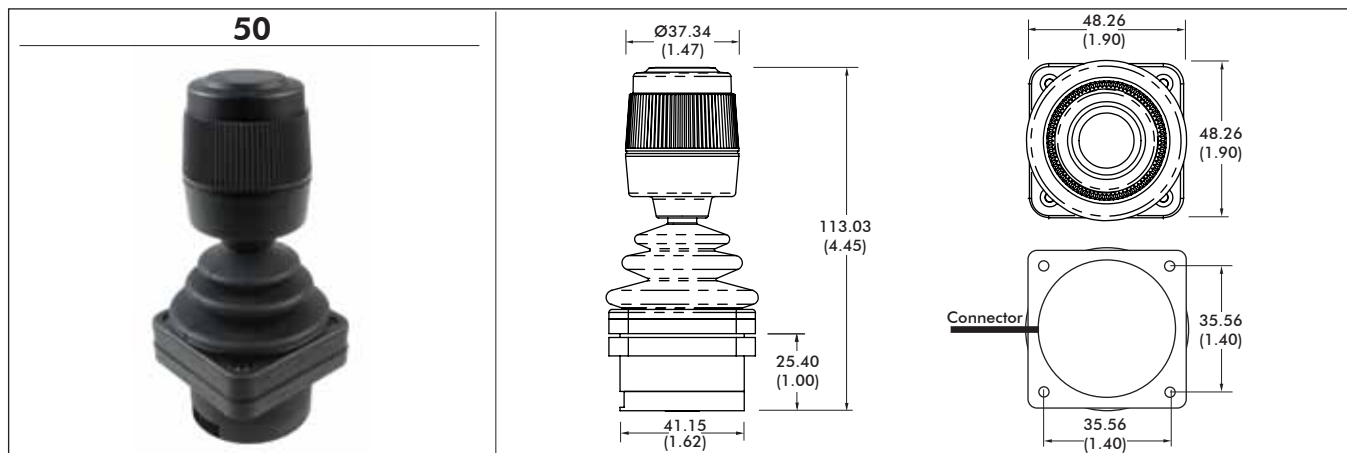

HF series

Hall effect joysticks

Overview

PANEL CUT-OUT DIMENSIONS

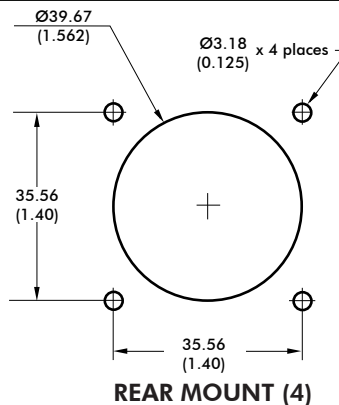
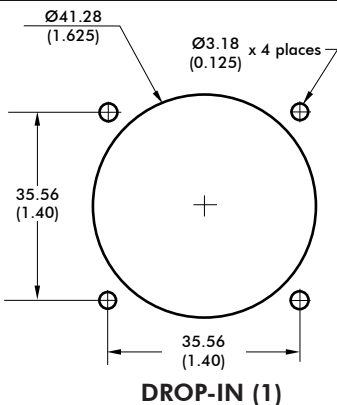

* Not available for Option 11 and 55 Handles

MOUNTING OPTIONS

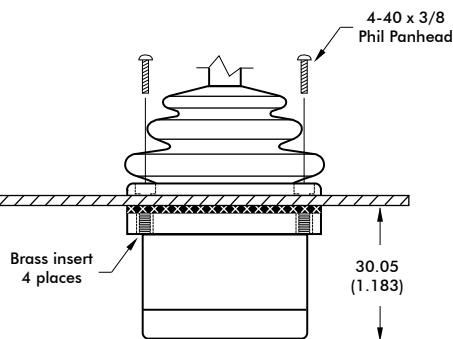
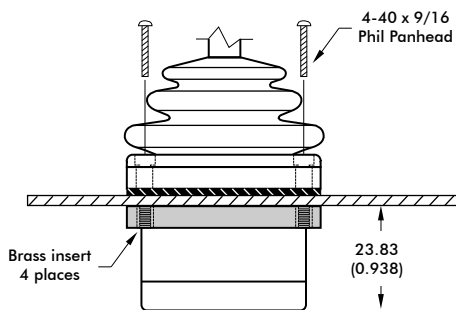

CLAMPING RING

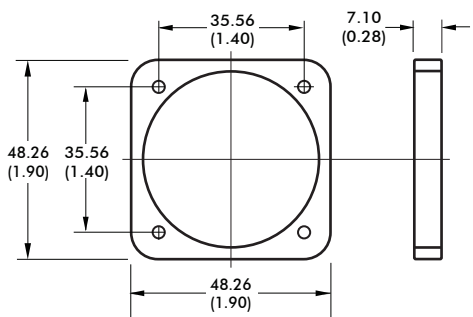

NOTES:

- For DROP-IN mounting, the panel thickness can be 1.17mm to 3.17mm (0.046in to 0.125in).
- For REAR MOUNT the maximum panel thickness is 1.6mm (0.063in).
- A panel thickness of 1/16" (1.6mm/0.063in) was considered for all the below-panel depth values.
- The below-panel depth is extended by 7.11 mm (0.28in) with the USB, Cursor Emulation, Voltage Regulator options.

- Panel
- Gasket
- Rear Mount Gasket

NOTES:

1. Dimensions are in mm/(inch).
2. Axis orientation:

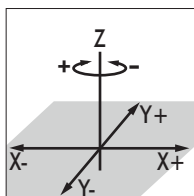

HF series

Hall effect joysticks

Overview

VOLTAGE OUTPUT OPTIONS

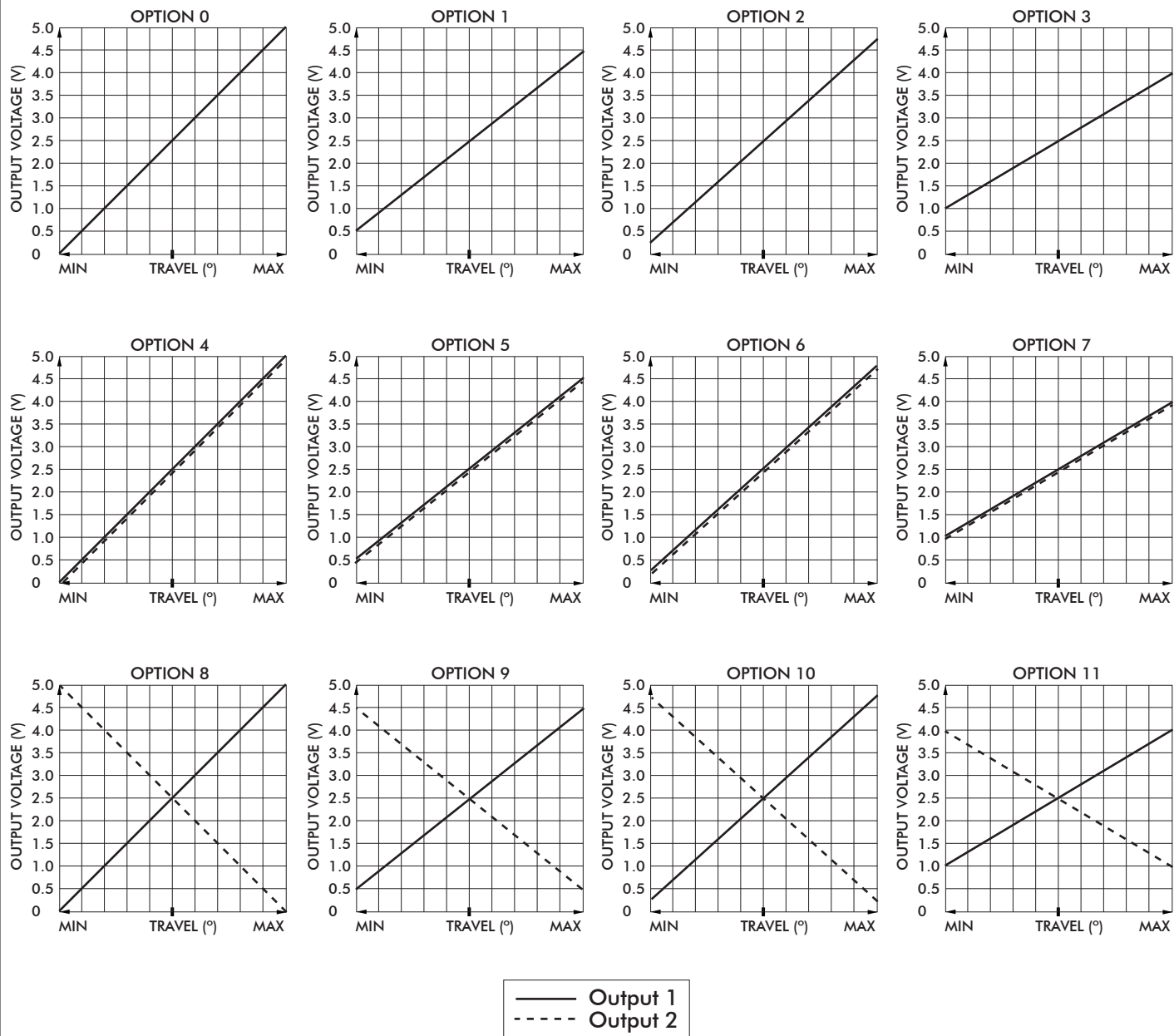

HF series

Hall effect joysticks

Overview

USB

USB

Featuring USB 1.1 HID compliant interface, APEM's USB joysticks are recognized as standard HID "game controller" devices. Adhering to the HID specification, APEM's USB joysticks are plug-and-play with most versions of Windows and Linux. Joystick button and axis assignments are dependent upon the controlled application.

FEATURES

- USB 1.1 HID compliant "game controller" device
- Easy to install and operate
- Functions determined by controlled application
- Standard Male Type A Connector

SUPPLIED WIRING

USB: USB Male Type A Connector with overmolded cable

CURSOR EMULATION

The Cursor Emulation option converts multi-axis joystick output into a mouse, trackball, or cursor control device. The joystick's internal microprocessor converts absolute axis position into a cursor velocity, which is translated as a relative trackball or mouse position.

APPLICATIONS

The Cursor Emulation option is ideal for vehicle applications subjected to dirt and high vibration which makes operating a traditional cursor control device difficult. The Cursor Emulation option is widely used in marine and military applications.

FEATURES

- HID compliant "pointing device"
- Plug-and-play with USB option
- Ideal for marine GPS and navigation

SUPPLIED WIRING

USB: USB Male Type A to mini B

I/O COMPLEMENT/ USER SPECIFIED PARAMETERS:

- USB 2 pushbuttons 2 or 3 axes (X, Y, and Z "scroll")

ADDITIONAL OUTPUT OPTIONS

VOLTAGE REGULATOR

The Voltage Regulator option may be used when the voltage is greater than 5V or when bipolar output is required.

User Specified Output Voltage:

- 0-5VDC
- ±10VDC

ELECTRICAL SPECIFICATIONS

- Supply Voltage: (Output Voltage + 1V) to 35V
- Supply Current: 90mA max

WIRING SPECIFICATION

- Red wire: Supply (+35V max.)
- Black wire: Ground
- Blue wire: X axis output
- Yellow wire: Y axis output
- Green wire: Z axis output
- White wire: Pushbutton common wire
- Orange,violet,grey,brown,pink,bl/wt/y/bk, gn/bk,gy/w wire: Pushbutton outputs